

FireBall PRO

Product code: 43177

Preface

Thank you for purchasing this Showtec product.

The purpose of this user manual is to provide instructions for the correct and safe use of this product.

Keep the user manual for future reference as it is an integral part of the product. The user manual shall be stored at an easily accessible location.

This user manual contains information concerning:

- Safety instructions
- Intended and non-intended use of the device
- Installation and operation of the device
- Maintenance procedures
- Troubleshooting
- Transport, storage and disposal of the device

Non-observance of the instructions in this user manual may result in serious injuries and damage of property.

©2025 Showtec. All rights reserved.

No part of this document may be copied, published or otherwise reproduced without the prior written consent of Highlite International.

Design and product specifications are subject to change without prior notice.

For the latest version of this document or other language versions, please visit our website www.highlite.com or contact us at service@highlite.com.

Highlite International and its authorized service providers are not liable for any injury, damage, direct or indirect loss, consequential or economic loss or any other loss arising from the use of, or inability to use or reliance on the information contained in this document.

Highlite International B.V. – Vestastraat 2 – 6468 EX Kerkrade – the Netherlands

Table of contents

1. Introduction	4
1.1. Before Using the Product	4
1.2. Intended Use	4
1.3. LEDs Lifespan	4
1.4. Product Lifespan	4
1.5. Text Conventions	4
1.6. Symbols and Signal Words	5
1.7. Symbols on the Information Label	5
2. Safety	6
2.1. Warnings and Safety Instructions	6
2.2. Requirements for the User	8
2.3. Personal Protective Equipment	8
3. Description of the Device	9
3.1. Front View	9
3.2. Back View	10
3.3. Base Plate	10
3.4. Product Specifications	11
3.5. Dimensions	12
4. Installation	13
4.1. Safety Instructions for Installation	13
4.2. Personal Protective Equipment	13
4.3. Installation Site Requirements	13
4.4. Rigging	14
4.5. Connecting to Power Supply	15
4.6. Power Linking of Multiple Devices	15
5. Setup	16
5.1. Warnings and Precautions	16
5.2. Stand-alone Setup	16
5.3. DMX Connection	16
5.3.1. DMX-512 Protocol	16
5.3.2. DMX Cables	17
5.3.3. Master/Slave Setup	17
5.3.4. DMX Linking	18
5.3.5. DMX Addressing	18
6. Operation	19
6.1. Safety Instructions for Operation	19
6.2. Control Modes	19
6.3. Control Panel	20
6.4. Start-up	20
6.5. Menu Overview	21
6.6. Main Menu Options	23
6.6.1. DMX Functions	23
6.6.1.1. DMX Address	23
6.6.1.2. Channel Mode	24
6.6.1.3. DMX Fail	24
6.6.2. Show Settings	24
6.6.2.1. Sound Settings	25
6.6.2.2. Show Chase	25
6.6.2.3. Slave Mode	25
6.6.3. Auto Test	26
6.6.4. Manual Mode	27
6.6.5. Display Settings	27
6.6.6. Fixture Information	28
6.6.7. Special Functions	28
6.7. DMX Channels	29
6.7.1. DMX Channels Overview 7 CH, 10 CH, 14 CH, 22 CH	29
6.7.2. DMX Channels Overview 28 CH	30

6.7.3.	7 CH (7 Channels).....	31
6.7.4.	10 CH (10 channels), 14 CH (14 Channels), 22 CH (22 Channels).....	32
6.7.5.	28 CH (28 Channels).....	34
6.8.	RDM Information.....	36
6.8.1.	RDM Details.....	36
6.8.2.	Supported RDM PIDs (Parameter IDs).....	36
7.	Troubleshooting.....	37
8.	Maintenance.....	38
8.1.	Safety Instructions for Maintenance.....	38
8.2.	Preventive Maintenance.....	38
8.2.1.	Basic Cleaning Instructions.....	38
8.3.	Corrective Maintenance.....	38
8.3.1.	Replacing the Fuse.....	39
9.	Deinstallation, Transportation and Storage.....	40
9.1.	Instructions for Deinstallation.....	40
9.2.	Instructions for Transportation.....	40
9.3.	Storage.....	40
10.	Disposal.....	40
11.	Approval.....	40

1. Introduction

1.1. Before Using the Product



Important

Read and follow the instructions in this user manual before installing, operating or servicing this product.

The manufacturer will not accept liability for any resulting damages caused by the non-observance of this manual.

After unpacking, check the contents of the box. If any parts are missing or damaged, contact your Highlite International dealer.

Your shipment includes:

- Showtec FireBall PRO
- Schuko to Power Pro (blue) cable (1,5 m)
- Quick-lock bracket
- User manual

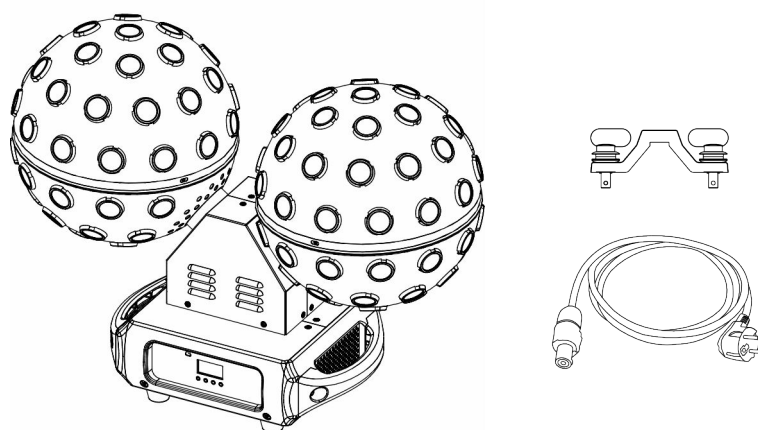

Figure 1

1.2. Intended Use

This device is intended for professional use as an RGBW mirror ball effect. It can be installed only indoors. This device is not suitable for households and for general lighting.

Any other use, not mentioned under intended use, is regarded as non-intended and incorrect use.

1.3. LEDs Lifespan

The light output of the LEDs gradually decreases over time (lumen depreciation). High operating temperatures contribute to this process. You can extend the lifespan of the LEDs by providing adequate ventilation and operating the LEDs at the lowest possible brightness.

1.4. Product Lifespan

This device is not designed for permanent operation.

Disconnect the device from the electrical power supply when the device is not in operation. This will reduce the wear and will improve the lifespan of the device.

1.5. Text Conventions

Throughout the user manual the following text conventions are used:

- Buttons: All buttons are in bold lettering, for example "Press the **UP/DOWN** buttons"
- References: References to parts of the device are in bold lettering, for example: "turn the **adjustment handle (05)**". References to chapters are hyperlinked
- 0–255: Defines a range of values
- Notes: **Note:** (in bold lettering) is followed by useful information or tips

1.6. Symbols and Signal Words

Safety notes and warnings are indicated throughout the user manual by safety signs.

Always follow the instructions provided in this user manual.



DANGER

Indicates an imminently hazardous situation which, if not avoided, will result in death or serious injury.



WARNING

Indicates a potentially hazardous situation which, if not avoided, could result in death or serious injury.



CAUTION

Indicates a potentially hazardous situation, which, if not avoided, may result in minor or moderate injury.



Attention

Indicates important information for the correct operation and use of the product.



Important

Read and observe the instructions in this document.



Electrical hazard



Eye damage hazard



Provides important information about the disposal of this product.

1.7. Symbols on the Information Label

This product is provided with an information label. The information label is located on the base plate of the device.

The information label contains the following symbols:



This device shall not be treated as household waste.



Read and follow the instructions in the user manual before installing, operating or servicing the device.



This device falls under IEC protection class I.

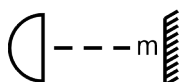

Minimum distance from lighted objects

IP20

This device is rated IP20.



Warning: Risk of electric shock. Do not open.

Warning: To reduce the risk of fire or electric shock do not expose this equipment to rain or moisture.

2. Safety



Important
Read and follow the instructions in this user manual before installing, operating or servicing this product.

The manufacturer will not accept liability for any resulting damages caused by the non-observance of this manual.

2.1. Warnings and Safety Instructions



DANGER
Danger for children

For adult use only. The device must be installed beyond the reach of children.

- Do not leave any parts of the packaging (plastic bags, polystyrene foam, nails, etc.) within the reach of children. Packaging material is a potential source of danger for children.



DANGER
Electric shock caused by dangerous voltage inside

There are areas inside the device where dangerous touch voltage may be present.

- Do not open the device or remove any covers.
- Do not operate the device if the covers or the housing are open. Before operation, check if the housing is firmly closed and all screws are tightly fastened.
- Disconnect the device from the electrical power supply before service and maintenance, and when the device is not in use.



DANGER
Electric shock caused by short-circuit

This device falls under IEC protection Class I.

- Make sure that the device is electrically connected to ground (earth). Connect the device only to a socket-outlet with a ground (earth) connection.
- Do not cover the ground (earth) connection.
- Do not bypass the thermostatic switch or fuses.
- Replace fuses only with the same type and rating.
- Do not let the power cable come into contact with other cables. Handle the power cable and all connections with the mains with caution.
- Do not modify, bend, mechanically strain, put pressure on, pull or heat up the power cable.
- Make sure that the power cable is not crimped or damaged. Examine the power cable periodically for any defects.
- Do not immerse the device in water or other liquids. Do not install the device in a location where flooding may occur.
- Do not use the device during thunderstorms. Disconnect the device from the electrical power supply immediately.



WARNING
Risk of epileptic shock

Strobe lighting can trigger seizures in photosensitive epilepsy. Sensitive persons should avoid looking at strobe lights.



Attention
Power supply

- Before connecting the device to the power supply, make sure that the current, voltage and frequency match the input voltage, current and frequency specified on the information label on the device.
- Make sure that the cross-sectional area of the extension cords and power cables is sufficient for the required power consumption of the device.



Attention
General safety

- Do not insert objects into air vents.
- Do not connect the device to a dimmer pack.
- Do not switch the device on and off in short intervals. This reduces the device's life.
- Do not shake the device. Avoid brute force when installing or operating the device.
- Change the lens or the LEDs if they are visibly damaged to such an extent that their effectiveness is impaired, for example by cracks or deep scratches. Contact your Highlite International dealer for more information, as servicing can be performed only by instructed or skilled persons.
- If the device is dropped or struck, disconnect the device from the electrical power supply immediately.
- If the device is exposed to extreme temperature variations (e.g. after transportation), do not switch it on immediately. Let the device reach room temperature before switching it on, otherwise it may be damaged by the formed condensation.
- If the device fails to work properly, discontinue use immediately.



Attention
For professional use only
This device must be used only for the purposes it is designed for.

This device is intended for professional use as an RGBW mirror ball effect. Any incorrect use may lead to hazardous situations and result in injuries and material damage.

- This device is not suitable for households and for general lighting.
- This device is not designed for permanent operation.
- This device does not contain user-serviceable parts. Unauthorized modifications to the device will render the warranty void. Such modifications may result in injuries and material damage.



Attention
Before each use, examine the device visually for any defects.

Make sure that:

- All screws used for installing the device or parts of the device are tightly fastened and are not corroded.
- The safety devices are not damaged.
- There are no deformations on housings, fixings and installation points.
- The lens is not cracked or damaged.
- The power cables are not damaged and do not show any material fatigue.

**Attention****Do not expose the device to conditions that exceed the rated IP class conditions.**

This device is IP20 rated. IP (Ingress Protection) 20 class provides protection against solid objects greater than 12 mm, such as fingers, and no protection against harmful ingress of water.

2.2. Requirements for the User

This product may be used by ordinary persons. Maintenance may be carried out by ordinary persons. Installation and service shall be carried out only by instructed or skilled persons. Contact your Highlite International dealer for more information.

Instructed persons have been instructed and trained by a skilled person, or are supervised by a skilled person, for specific tasks and work activities associated with the installation, service and maintenance of this product, so that they can identify risks and take precautions to avoid them.

Skilled persons have training or experience, which enables them to recognize risks and avoid hazards associated with the installation, service and maintenance of this product.

Ordinary persons are all persons other than instructed persons and skilled persons. Ordinary persons include not only users of the product but also any other persons that may have access to the device or who may be in the vicinity of the device.

2.3. Personal Protective Equipment

During installation, deinstallation and rigging wear personal protective equipment in compliance with the national and site-specific regulations.

3. Description of the Device

The Showtec FireBall PRO is an RGBW mirror ball effect. It offers a powerful RGBW dual-mirror-ball-like effect. It has four 25 W RGBW LEDs in each ball, for a total of 200 W, and each ball has two independently controllable RGBW sections. Both balls rotate independently, endlessly, and bi-directionally. The carrier head can rotate bi-directionally as well. Both balls create 2-degree beams and offer 360° coverage with 57 lenses/beams each to create romantic atmospheres and dynamic disco effects.

The FireBall PRO can be controlled via DMX, manual, master/slave or stand-alone operation. Built-in programs and effects can be applied in sound, auto and DMX mode. It has an OLED display for control and parameter adjustments. The FireBall PRO can be positioned upwards on any surface or downwards with the included quick-lock bracket (see [1.1. Before Using the Product](#) on page 4). Multiple units can be daisy-chained using both DMX and Power Pro connectors.

3.1. Front View

Figure 2

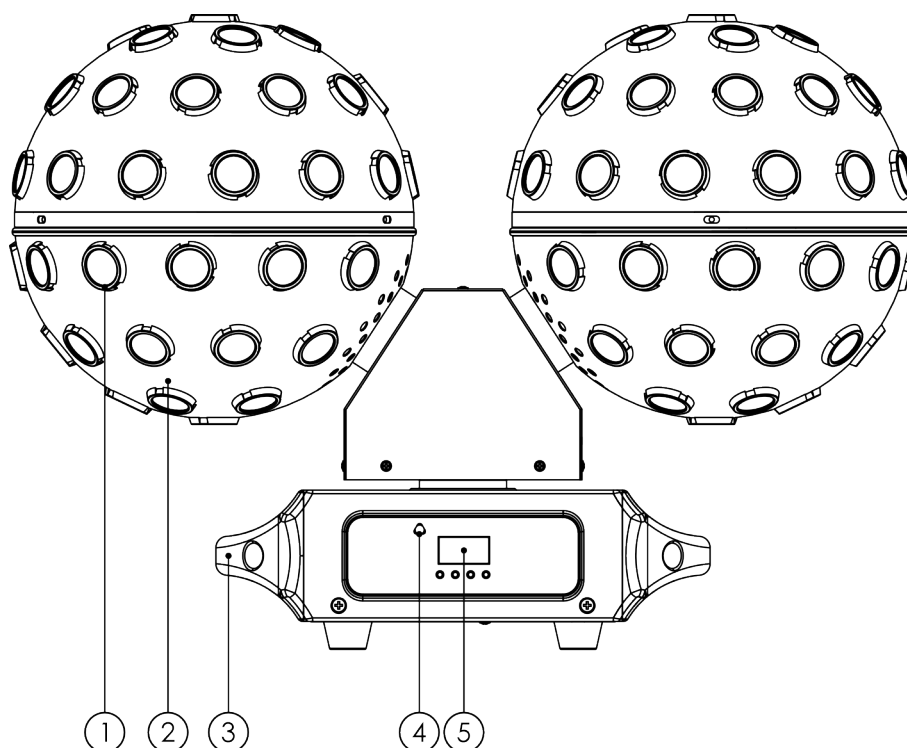

- 01) 4 x 25W RGBW LEDs for each ball
- 02) 57 x lenses for each ball
- 03) 2 x Carrying handle
- 04) Built-in microphone
- 05) Control panel: OLED display and control buttons

3.2. Back View

Figure 3

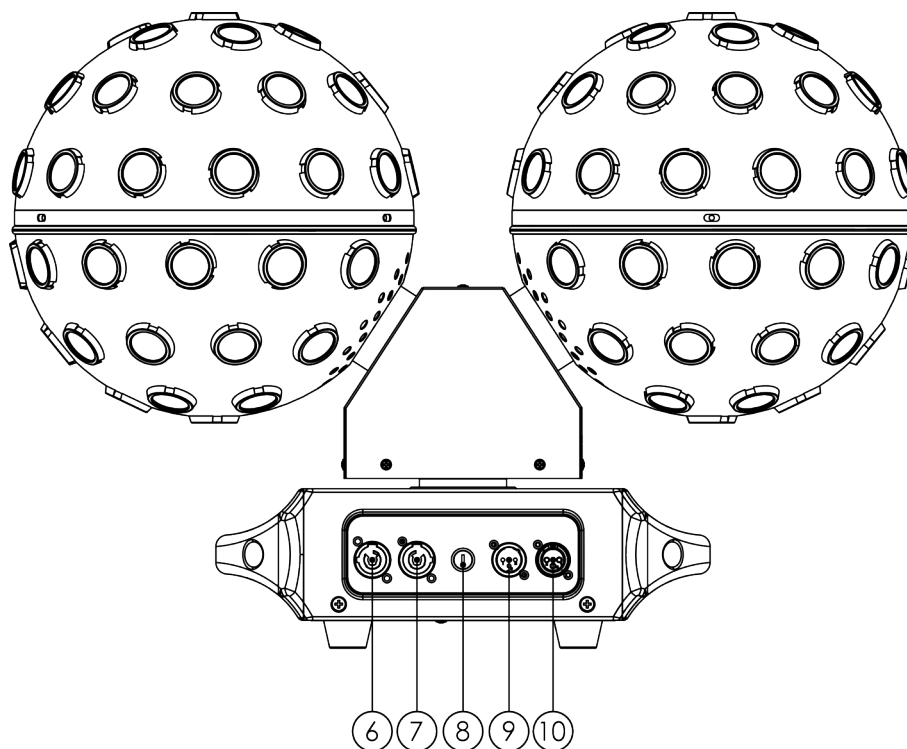

- 06) Power Pro connector IN (blue)
- 07) Power Pro connector OUT (gray)
- 08) Fuse T3.15 A 250V
- 09) 3-pin DMX signal connector IN
- 10) 3-pin DMX signal connector OUT

3.3. Base Plate

Figure 4

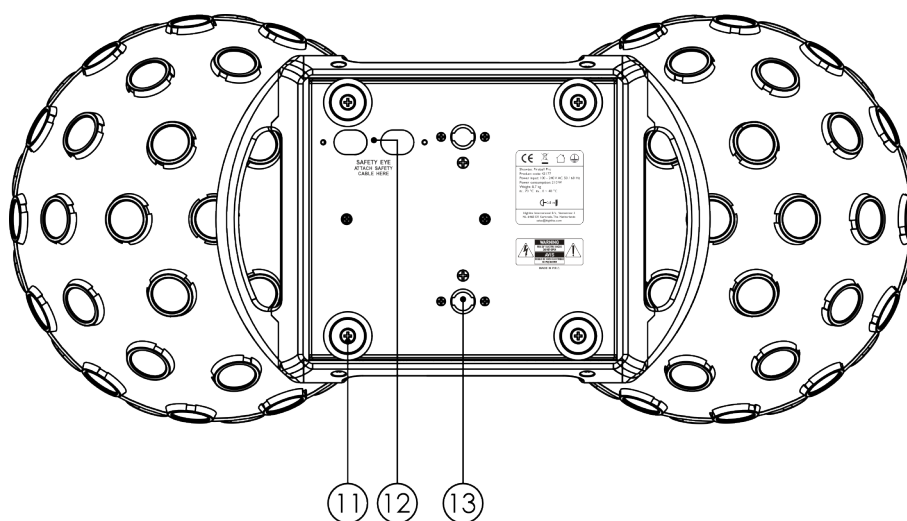

- 11) 4 x Rubber feet
- 12) 2 x opening for a safety cable
- 13) 2 x mounting hole for quick-lock bracket

3.4. Product Specifications

Model:	FireBall PRO
Source:	
Light source type	LED
Light source quantity	8
Light source power	25 W
LED color type	RGBW
Refresh rate	4000 Hz
Illuminance @ 2 m	3.860 lx
Optical:	
Beam angle (circular)	2°
Control and Programming:	
Control mode	Built-in Program / DMX / Manual / Master Slave / Sound
DMX channels	7 / 10 / 14 / 22 / 28
Protocols	DMX / RDM
Display	OLED
Movement:	
Pan	360°
Continuous movement	Rotating optics
Electrical Specifications and Connections:	
Power supply	100–240 V AC 50/60 Hz
Power consumption	210 W
Power connector IN	Power Pro Blue
Power connector OUT	Power Pro Grey
DMX connector	XLR 3P IN/OUT
Mechanical Specifications:	
Height	414 mm
Width	590 mm
Depth	266 mm
Weight	8,7 kg
IP rating	IP20 (indoor use only)
Housing	Metal / Plastic
Color	Black
Product Properties:	
Cooling	Active
Rigging:	
Mounting options	Floor / Quick-lock
Safety attachment	Yes
Thermal Specifications:	
Maximum ambient temperature	40 °C
Included Items:	
Included cables	Power Pro cable
Included rigging	Quick-lock bracket

3.5. Dimensions

Figure 5

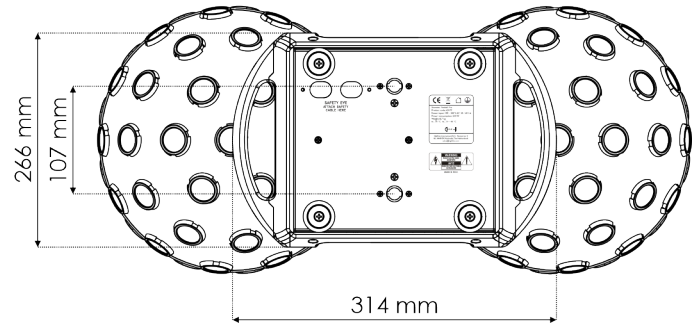
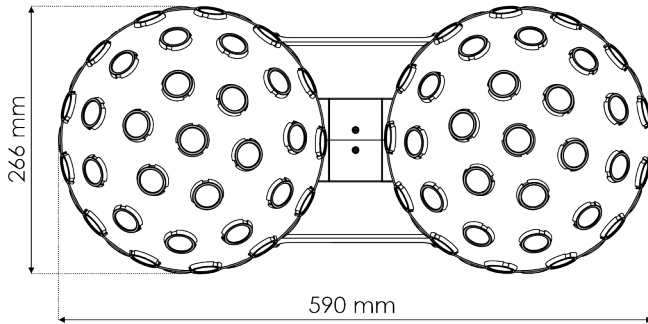
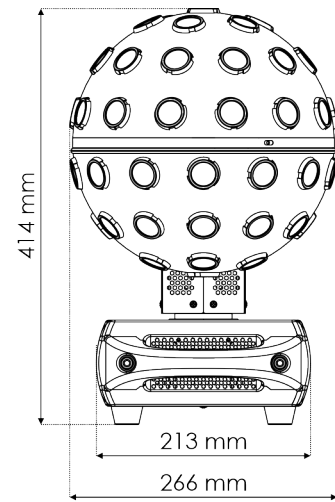
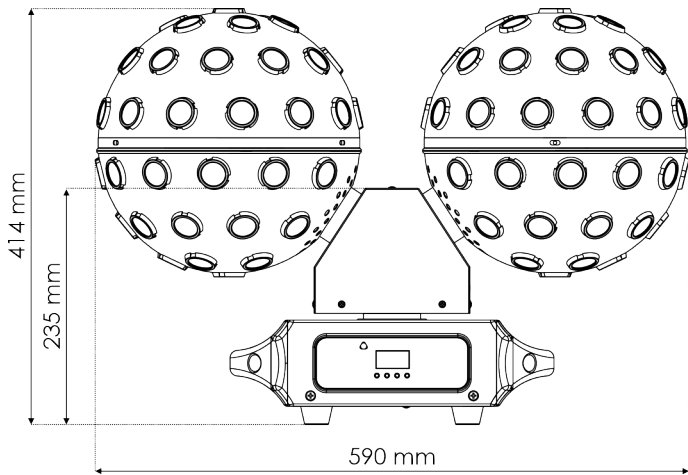

4. Installation

4.1. Safety Instructions for Installation

**WARNING**

Incorrect installation can cause serious injuries and damage of property.

If trussing systems are used, installation must be carried out only by instructed or skilled persons.

Follow all applicable European, national and local safety regulations concerning rigging and trussing.

4.2. Personal Protective Equipment

During installation, deinstallation and rigging wear personal protective equipment in compliance with the national and site-specific regulations.

4.3. Installation Site Requirements

- The device can be used only indoors.
- The minimum distance to other objects must be bigger than 0,8 m.
- The maximum ambient temperature $t_a = 40\text{ °C}$ must never be exceeded.
- The relative humidity must not exceed 50 % with an ambient temperature of 40 °C.

4.4. Rigging

The device can be positioned on a flat surface or mounted to a truss or other rigging structure upside down. Make sure that all loads are within the pre-determined limits of the supporting structure.

**CAUTION**

Restrict the access under the work area during rigging/derigging.

To mount the device, follow the steps below:

- 01) Install a clamp on the quick-lock bracket, supplied with the device. Make sure that you use a clamp suitable for attaching the device to a truss.
- 02) Fasten the quick-lock bracket on the **mounting holes for quick-lock brackets (13)**.

Figure 6

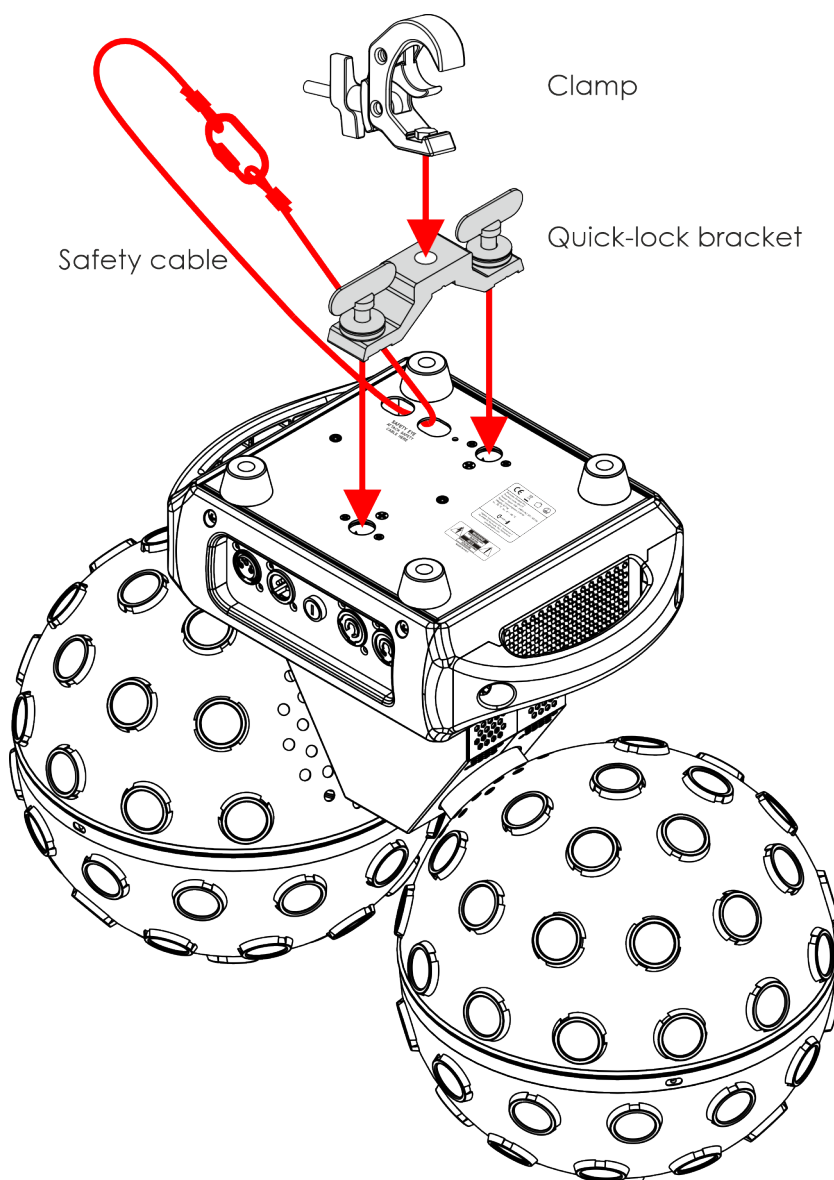

- 03) Attach the device to the supporting structure. Make sure that the device cannot move freely.
- 04) Secure the device with a secondary suspension, for example a safety cable. Make sure that the secondary suspension can hold 10 times the weight of the device. If possible, the secondary suspension should be attached to a supporting structure independent of the primary suspension. Put the safety cable through the **openings for safety cable (12)**.

4.5. Connecting to Power Supply



DANGER
Electric shock caused by short-circuit

The device accepts AC mains power at 100–240 V and 50/60 Hz. Do not supply power at any other voltage or frequency to the device.

This device falls under IEC protection class I. Make sure that the device is always electrically connected to the ground (earth).

Before connecting the device to the socket-outlet:

- Make sure that the power supply matches the input voltage specified on the information label on the device.
- Make sure that the socket-outlet has a ground (earth) connection.

Connect the device to the socket-outlet with the power plug. Do not connect the device to a dimmer circuit, as this may damage the device.

4.6. Power Linking of Multiple Devices

This device supports power linking. Power can be relayed to another device via the power OUT connector. Note that the input and the output connectors have different designs: one type cannot be connected to the other.

Power linking of multiple devices must be carried out only by instructed or skilled persons.



WARNING
Incorrect power linking may lead to overload of the electrical circuit and result in serious injuries and damage of property.

To prevent overload of the electrical circuit, when power linking multiple devices:

- Use cables with sufficient current-carrying capacity. The power cable supplied with the device is not suitable for power linking of multiple devices.
- Make sure that the total current draw of the device and all connected devices does not exceed the rated capacity of the power cables and the circuit breaker.
- Do not link more devices on one power link than the maximum recommended number.

Maximum recommended number of devices:

- at 100–120 V: 4 devices FireBall PRO
- at 200–240 V: 8 devices FireBall PRO

5. Setup

5.1. Warnings and Precautions

**Attention**

Connect all data cables before supplying power.

Disconnect power supply before connecting or disconnecting data cables.

5.2. Stand-alone Setup

For the complete instructions of operation of this device, refer to the user manual. You can find the latest version of the user manual on our website www.highlite.com.

When the FireBall PRO is not connected to a controller or to other devices, it functions as a stand-alone device. It can be operated manually via the control panel. Multiple devices can be connected and used in master/slave mode.

For more information refer to Control Modes.

5.3. DMX Connection

5.3.1. DMX-512 Protocol

You need a DMX serial data link to run light shows of one or more devices using a DMX-512 controller.

The FireBall PRO has 3-pin DMX signal IN and OUT connectors.

The pin assignment is as follows: pin 1 (ground), pin 2 (-), pin 3 (+).

Devices on a serial data link must be daisy-chained in a single line. The number of devices that you can control on one data link is limited by the combined number of the DMX channels of the connected devices and the 512 channels available in one DMX universe.

To comply with the TIA-485 standard, no more than 32 devices should be connected on one data link. In order to connect more than 32 devices on one data link, you must use a DMX optically isolated splitter/booster, otherwise this may result in deterioration of the DMX signal.

Note:

- Maximum recommended DMX data link distance: 300 m
- Maximum recommended number of devices on a DMX data link: 32 devices

5.3.2. DMX Cables

Shielded twisted-pair cables with 3-pin XLR connectors must be used for reliable DMX connection. You can purchase DMX cables directly from your Highlite International dealer or make your own cables.

If you use XLR audio cables for DMX data transmission, this may lead to signal degradation and unreliable operation of the DMX network.

When you make your own DMX cables, make sure that you connect the pins and wires correctly as shown in the figure below.

Figure 7

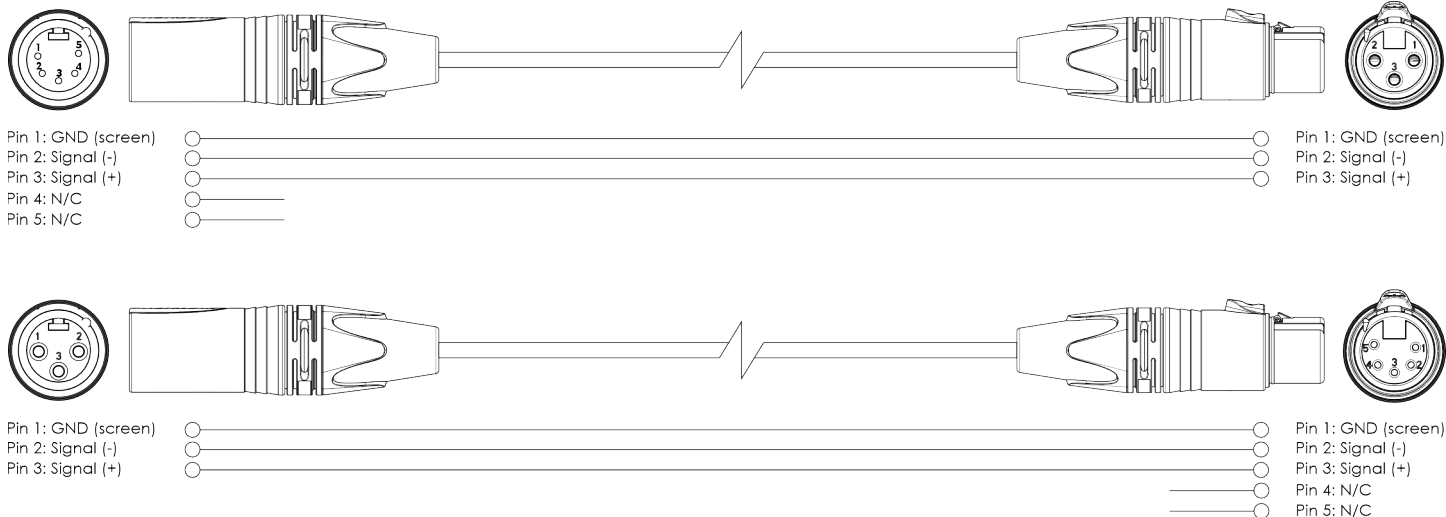

5.3.3. Master/Slave Setup

The FireBall PRO supports master/slave control mode. To connect multiple devices in a master/slave setup, follow the steps below:

- 01) Connect the DMX OUT connector of the 1st device to the DMX IN connector of the 2nd device with a 3-pin DMX cable.
- 02) Repeat step 1 to connect all devices in a daisy-chain.
- 03) Connect a DMX terminator (120 Ω resistor) to the DMX OUT connector of the last device on the data link.
- 04) Set the 1st device on the data link as a master device (see [6.6.2.3. Slave Mode](#) on page 25).
- 05) Set the remaining devices as slave devices (see [6.6.2.3. Slave Mode](#) on page 25).

Figure 8

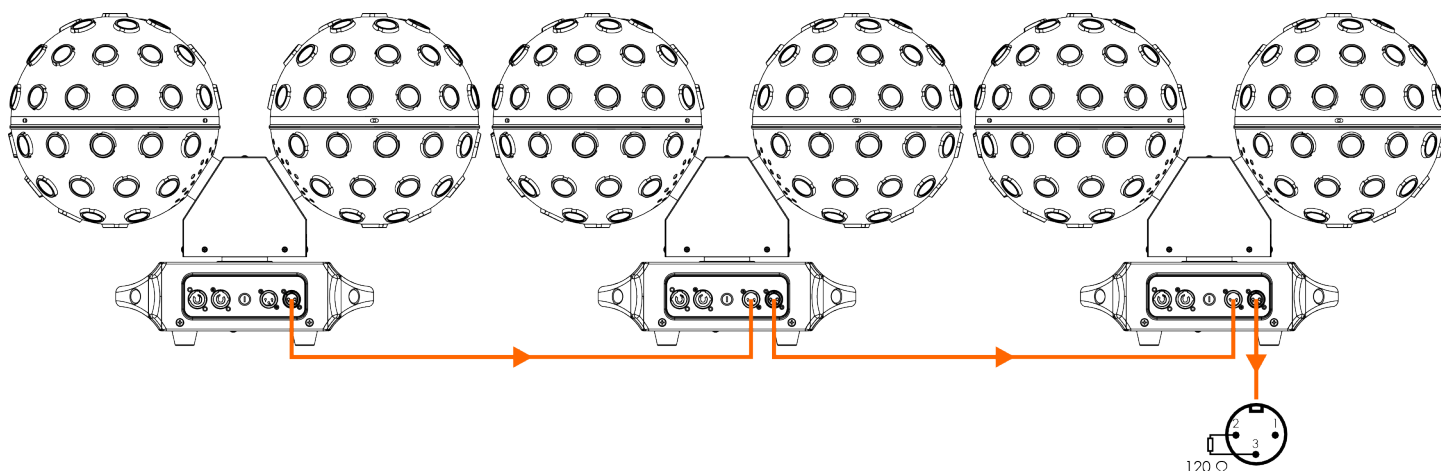

5.3.4. DMX Linking

To connect multiple devices on one DMX data link, follow the steps below:

- 01) Use a 3-pin DMX cable to connect the DMX OUT connector of the lighting controller to the DMX IN connector of the 1st device.
- 02) Connect the DMX OUT connector of the 1st device to the DMX IN connector of the 2nd device with a 3-pin DMX cable.
- 03) Repeat step 2 to connect all devices in a daisy-chain.
- 04) Connect a DMX terminator (120 Ω resistor) to the DMX OUT connector of the last device on the data link.

Figure 9

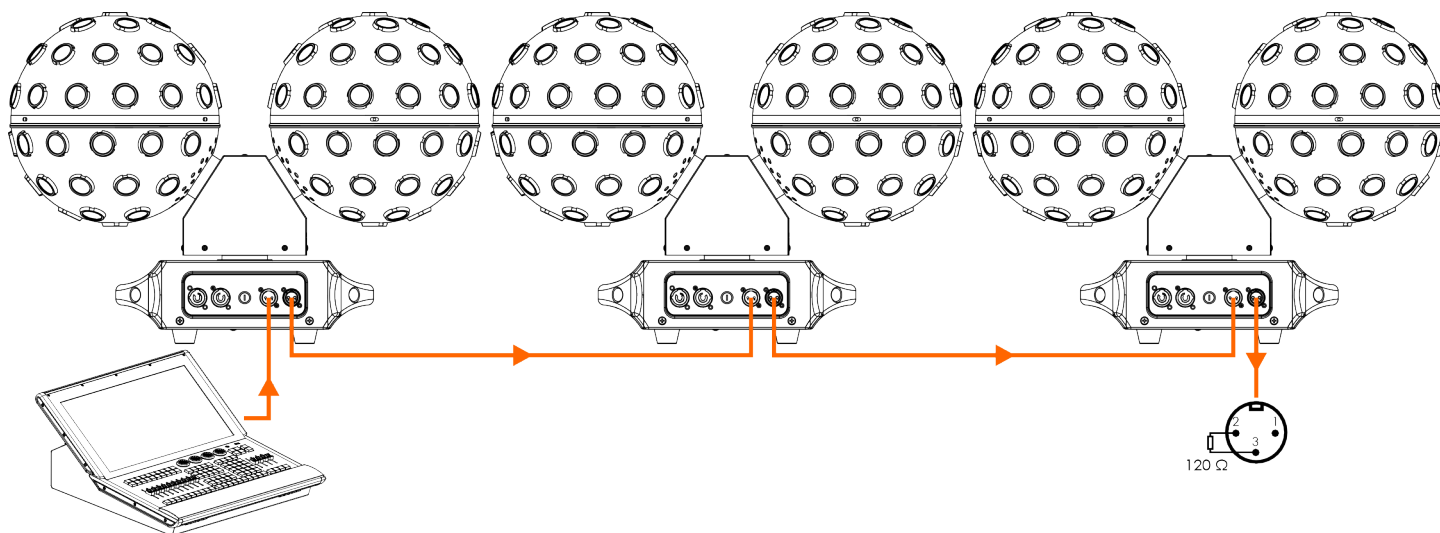

5.3.5. DMX Addressing

In a setup with multiple devices, make sure that you set the DMX starting address of each device correctly. The FireBall PRO has 5 personalities: 7 channels, 10 channels, 14 channels, 22 channels, 28 channels.

If you want to connect multiple devices on one data link and use them in 28-channel mode, for example, follow the steps below:

- 01) Set the starting address of the 1st device on the data link to 1 (001).
- 02) Set the starting address of the 2nd device on the data link to 29 (029), as $1 + 28 = 29$.
- 03) Set the starting address of the 3rd device on the data link to 57 (057), as $29 + 28 = 57$.
- 04) Continue assigning the starting addresses of the remaining devices by adding 28 each time to the previous number.

When addressing multiple devices on one data link, make sure that there are no overlapping channels. You cannot control devices individually if they have overlapping channels.

6. Operation

6.1. Safety Instructions for Operation

**Attention**

This device must be used only for the purposes it is designed for.

This device is intended for professional use as an RGBW mirror ball effect. It can be installed only indoors. This device is not suitable for households and for general lighting.

Any other use, not mentioned under intended use, is regarded as non-intended and incorrect use.

**Attention****Power supply**

Before connecting the device to the power supply, make sure that the current, voltage and frequency match the input voltage, current and frequency specified on the information label on the device.

6.2. Control Modes

The FireBall PRO supports the following control modes:

- Stand-alone: Manual control, sound control, built-in programs
- Master/Slave: Manual control, sound control, built-in programs
- DMX-512: 7 channels, 10 channels, 14 channels, 22 channels, 28 channels

For more information about how to connect the device, refer to Setup (see [5. Setup](#) on page 16).

To operate the device manually as a stand-alone device or in a master/slave setup:

- Set up the master/slave mode in the Show Settings menu (see [6.6.2.3. Slave Mode](#) on page 25).
- Adjust the parameters for manual control in the Manual Mode menu (see [6.6.4. Manual Mode](#) on page 27).
- Select a built-in program in the Show Settings menu (see [6.6.2.2. Show Chase](#) on page 25).
- Set up the device in sound control mode in the Show Settings menu (see [6.6.2.1. Sound Settings](#) on page 25).

To operate the device with a DMX controller:

- Select a DMX personality in the DMX Functions menu (see [6.6.1.2. Channel Mode](#) on page 24). Refer to DMX channels (see [6.7. DMX Channels](#) on page 29) for a complete overview of all DMX channels.
- Set the DMX starting address of the device in the DMX Functions menu (see [6.6.1.1. DMX Address](#) on page 23).

6.3. Control Panel

Figure 10

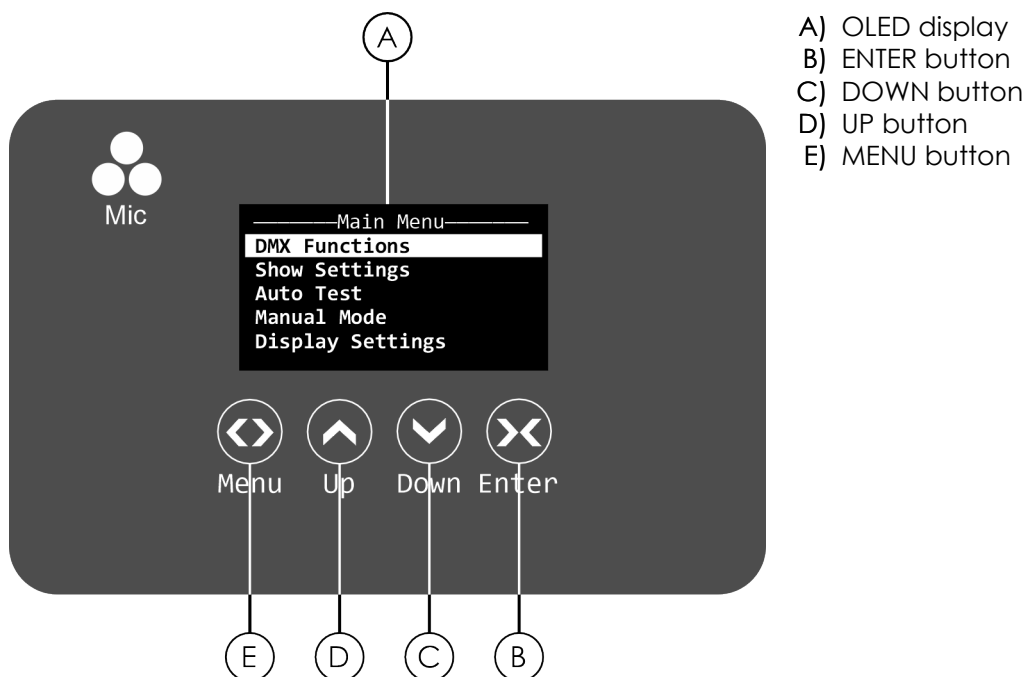

- A) OLED display
- B) ENTER button
- C) DOWN button
- D) UP button
- E) MENU button

- Use the **MENU** button to exit the current submenu, to return to the Main Menu and to return to the start screen.
- Use the **UP/DOWN** buttons to navigate through the menus or to increase/decrease numeric values.
- Use the **ENTER** button to open the desired menu, to confirm your choice or to set the currently selected value.

6.4. Start-up

Upon start-up the display shows a splash screen with the Showtec logo and the name of the device:



Immediately afterwards, the display shows the start screen. The start screen provides information about the selected control mode, the selected built-in program and the temperature of the fixture:

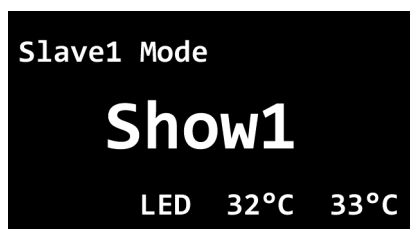

Press the **MENU** button to open the main menu (see [6.6. Main Menu Options](#) on page 23).

Note:

If no button is pressed, after 30 seconds of inactivity the display will turn off. Press any button to turn the display on. You can adjust whether the display turns off automatically in the Special Functions menu (see [6.6.7. Special Functions](#) on page 28).

6.5. Menu Overview

Menu 1	Menu 2	Menu 3	Menu 4
DMX Functions (see 6.6.1. DMX Functions)	DMX Address	001–485/491/499/503/506 depending on Ch mode	
	Channel	7 Channel	
		10 Channel	
		14 Channel	
		22 Channel	
		28 Channel	
DMX Fail	Blackout		
	Hold		
	Program		
Show Settings (see 6.6.2. Show Settings)	Sound Settings	Sound	Yes
			No
	Show Chase	Sensitivity	000–100
		Show 0	SP00–99
		Show 1	SP00–99
		Show 2	SP00–99
		Show 3	SP00–99
		Show 4	SP00–99
		Show 5	SP00–99
		Show 6	SP00–99
		Show 7	SP00–99
		Show 8	SP00–99
		Show 9	SP00–99
		Show 10	SP00–99
		Show 11	SP00–99
		Show 12	SP00–99
	Show 13	SP00–99	
	Show 14	SP00–99	
	Slave Mode	Master	
		Slave1	
Slave2			
Auto Test (see 6.6.3. Auto Test)	Auto Test...	In order: Pan CW rot. Pan CCW rot. Rotation left ball CCW+CW rot. Rotation right ball CCW+CW rot. Red for each segment Green for each segment Blue for each segment White for each segment Full on all segments Strobe full on for all segments Full on all segments + rotate all	

Menu 1	Menu 2	Menu 3	Menu 4
Manual Mode (see 6.6.4. Manual Mode)	Red L (Zone 1–2)	000–255	
	Red R (Zone 3–4)	000–255	
	Green L (Zone 1–2)	000–255	
	Green R (Zone 3–4)	000–255	
	Blue L (Zone 1–2)	000–255	
	Blue R (Zone 3–4)	000–255	
	White L (Zone 1–2)	000–255	
	White R (Zone 3–4)	000–255	
	Rotation L	000–015 Stop 016–134 CCW rotation, from fast to slow 135–255 CW rotation, from slow to fast	
	Rotation R	000–015 Stop 016–134 CCW rotation, from fast to slow 135–255 CW rotation, from slow to fast	
	Pan	000–255	
	RPan	000–015 Stop 016–134 CW rotation, from fast to slow 135–255 CCW rotation, from slow to fast	
	Dimmer	000–255	
	Strobe	000–009 No function 010–110 Strobe, from low to high frequency 111–115 No function 116–182 Pulse strobe, from low to high frequency 183–187 No function 188–255 Random strobe, from low to high frequency	
Display Settings (see 6.6.5. Display Settings)	Backlight Auto Off	No Yes	
	Display Inverse	No Yes	
	Display Contrast	0–10	
Fixture Information (see 6.6.6. Fixture Information)	RDM UID	29B4: 10Cxxxxx	
	Fixture Use Time	5	
	Firmware Version	CPU-A V 1.0 B 1.0 CPU-B V 1.0 B 1.0	
Special Functions (see 6.6.7. Special Functions)	Factory Setting	No Yes	

6.6. Main Menu Options

The main menu has the following 7 options:

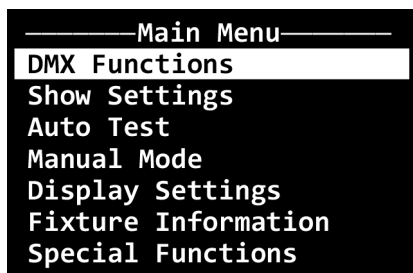

DMX Functions
 Show Settings
 Auto Test
 Manual Mode
 Display Settings
 Fixture Information
 Special Functions

- 01) Press the **UP/DOWN** buttons to navigate through the main menu.
- 02) Press the **ENTER** button to open submenus.

6.6.1. DMX Functions

In this menu you can set the DMX starting address of the device, change the DMX control mode and determine the behavior of the device in case there is no DMX signal.

- 01) Press the **UP/DOWN** buttons to select one of the 3 options:

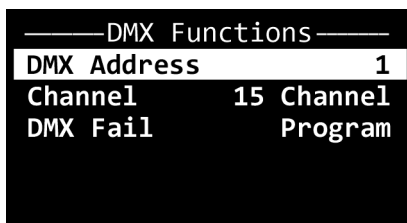

- DMX Address (see [6.6.1.1. DMX Address](#))
- Channel Mode (see [6.6.1.2. Channel Mode](#))
- DMX Fail (see [6.6.1.3. DMX Fail](#))

- 02) Press the **ENTER** button to confirm the selection.

6.6.1.1. DMX Address

In this submenu you can set the DMX starting address of the device.

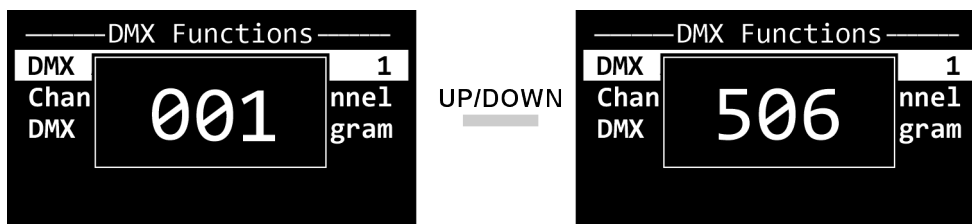

- 01) Press the **UP/DOWN** buttons to select the starting address of the device. The selection range depends on the active DMX channel mode:
 - 7 Channel: 001–506 (7 channels)
 - 10 Channel: 001–503 (10 channels)
 - 14 Channel: 001–499 (14 channels)
 - 22 Channel: 001–491 (22 channels)
 - 28 Channel: 001–485 (28 channels)
- 02) Press the **ENTER** button to confirm the selection.

6.6.1.2. Channel Mode

In this submenu you can select the DMX channel mode.

01) Press the **UP/DOWN** buttons to select one of the 5 options:

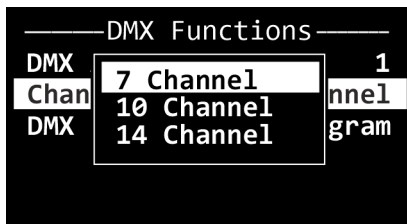

- 7 Channel
- 10 Channel
- 14 Channel
- 22 Channel
- 28 Channel

02) Press the **ENTER** button to confirm the selection.

6.6.1.3. DMX Fail

In this pop-up submenu you can determine the behavior of the device in case there is no DMX signal.

01) Press the **UP/DOWN** buttons to select one of the 3 options:

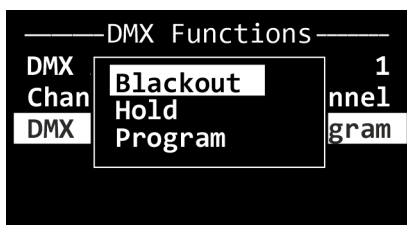

- Blackout: The device will black out the light output
- Hold: The device will use the last DMX signal received correctly
- Program: The device will use the last used built-in program that was selected in Show Settings (see [6.6.2. Show Settings](#) on page 24)

02) Press the **ENTER** button to confirm the selection.

6.6.2. Show Settings

In this menu you can adjust the settings for the sound mode, select a built-in chase and configure the device as a master or slave device.

01) Press the **UP/DOWN** buttons to select one of the 3 options:

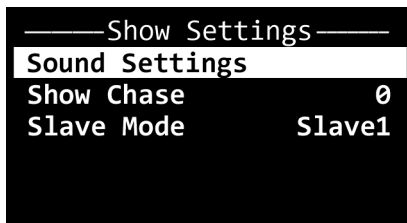

- Sound Settings (see [6.6.2.1. Sound Settings](#))
- Show Chase (see [6.6.2.2. Show Chase](#))
- Slave Mode (see [6.6.2.3. Slave Mode](#))

02) Press the **ENTER** button to confirm the selection.

6.6.2.1. Sound Settings

In this submenu you can turn the sound mode on or off and set the sensitivity of the sound mode.

01) Press the **UP/DOWN** buttons to select one of the 2 options:

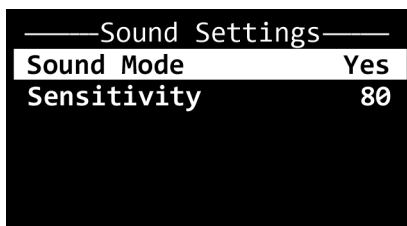

- Sound Mode: Turn the sound mode on or off (Yes/No)
- Sensitivity: Set the sensitivity of the sound mode from low to high (000–100) if the sound mode is active

02) Press the **ENTER** button to confirm the selection and open the pop-up submenu where you can adjust the settings.

03) Press the **UP/DOWN** buttons to select the desired setting.

04) Press the **ENTER** button to confirm the selection.

6.6.2.2. Show Chase

In this submenu you can run one of the show chases and adjust the speed of the selected show chase.

01) Press the **UP/DOWN** buttons to select one of the 15 show chases:

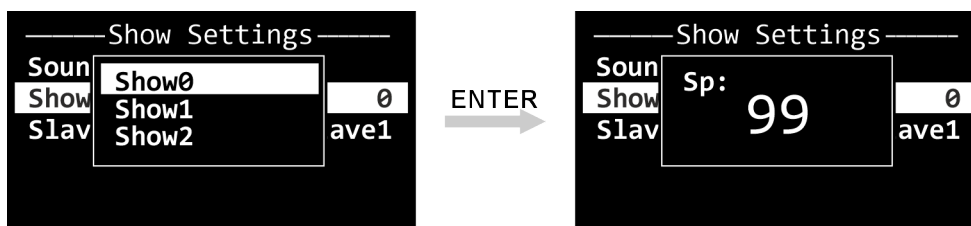

02) Press the **ENTER** button to confirm the selection and open the pop-up submenu where you can adjust the speed setting.

03) Press the **UP/DOWN** buttons to set the speed (0–99, from slow to fast).

04) Press the **ENTER** button to confirm the selection.

6.6.2.3. Slave Mode

In this submenu you can configure the device as a master or slave device.

01) Press the **UP/DOWN** buttons to select one of the 3 options:



- Master: Set the device as a master device or stand-alone device
- Slave1: Set the device as a slave device
- Slave2: Set the device as a slave device with an inverted pan rotation

02) Press the **ENTER** button to confirm the selection.

6.6.3. Auto Test

In this submenu you can automatically run an auto test of the functions of the device.

(If you have selected Auto Test in the previous menu and pressed the **ENTER** button) The device automatically runs an auto test of the functions of the device and the display shows:

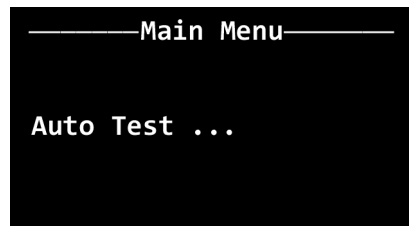

The device will test the following functions in the following order:

- 01) Pan CW rotation
- 02) Pan CCW rotation
- 03) Rotation left ball CCW+CW rotation
- 04) Rotation right ball CCW+CW rotation
- 05) Red for each segment
- 06) Green for each segment
- 07) Blue for each segment
- 08) White for each segment
- 09) Full on all segments
- 10) Strobe full on for all segments
- 11) Full on all segments + rotate all

6.6.4. Manual Mode

In this submenu you can manually configure the output settings of the device.

01) Press the **UP/DOWN** buttons to select one of the 14 options:

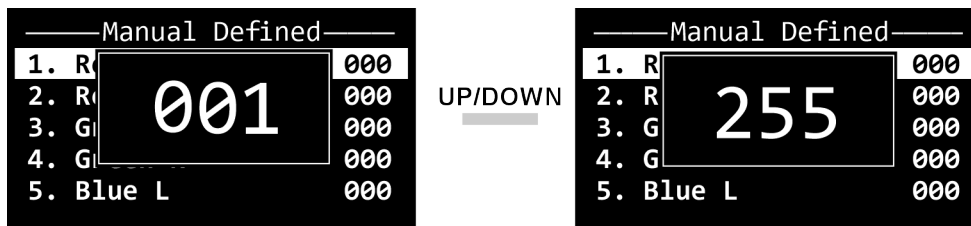

- Red L: Set the intensity of the red LED color for the left ball (000–255)
- Red R: Set the intensity of the red LED color for the right ball(000–255)
- Green L: Set the intensity of the green LED color for the left ball (000–255)
- Green R: Set the intensity of the green LED color for the right ball (000–255)
- Blue L: Set the intensity of the blue LED color for the left ball (000–255)
- Blue R: Set the intensity of the blue LED color for the right ball (000–255)
- White L: Set the intensity of the white LED color for the left ball (000–255)
- White R: Set the intensity of the white LED color for the right ball (000–255)
- Rotation L: Set the rotation speed of the left ball (000–015: the left ball stops/016–134 the left ball rotates counterclockwise from fast to slow/135–255: the left ball rotates clockwise from slow to fast)
- Rotation R: Set the rotation speed of the right ball (000–015: the right ball stops/016–134 the right ball rotates counterclockwise from fast to slow/135–255: the right ball rotates clockwise from slow to fast)
- Pan: Set the pan adjustment of the device from 0°–180° (000–255)
- R Pan: Set the pan rotation speed of the device (000–015: the device stops/016–134 the device rotates clockwise from fast to slow/135–255: the left ball rotates counterclockwise from slow to fast)
- Dimmer: Set the intensity of the light output (000–255)
- Strobe: Set the intensity of the strobe (000–009: the strobe is open/010–110: the strobe goes from slow to fast/111–115: the strobe is open/116–182: the strobe pulses from slow to fast/183–187: the strobe is open/188–255: the strobe is random from slow to fast)

02) Press the **ENTER** button to confirm the selection.

03) Press the **UP/DOWN** buttons to increase/decrease the value.

04) Press the **ENTER** button to confirm the selection.

6.6.5. Display Settings

In this menu you can adjust the display settings of the device.

01) Press the **UP/DOWN** buttons to select one of the 3 options:

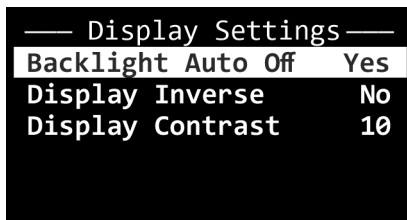

- Backlight Auto Off: Turn off the backlight of the OLED display automatically after 30 seconds of inactivity (No/Yes)
- Display Inverse: Rotate the OLED display at 180° (No/Yes)
- Display Contrast: Set the display contrast from low to high contrast (0–10)

02) Press the **ENTER** button to confirm the selection and open the pop-up submenu where you can adjust the settings.

03) Press the **UP/DOWN** buttons to select the desired setting.

04) Press the **ENTER** button to confirm the selection.

6.6.6. Fixture Information

In this menu you can view the UID, the LED operating hours and the firmware version of the device.

01) Press the **UP/DOWN** buttons to select one of the 3 options:

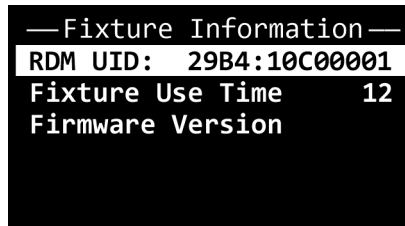

- RDM UID: View the unique identification (UID) number of the device
- Fixture Hour: View the operating hours of the LED
- Firmware Version: View the current firmware version

02) (When selecting Firmware Version) Press the **ENTER** button to select and view the firmware version.

6.6.7. Special Functions

In this menu you can reset the settings of the device to the default factory settings.

01) Press the **ENTER** button to select one of the 2 options:

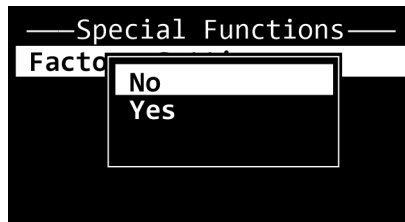

- No: Cancel the reset and return to the previous screen
- Yes: Reset all settings

02) Press the **ENTER** button to confirm your choice.

6.7. DMX Channels

6.7.1. DMX Channels Overview 7 CH, 10 CH, 14 CH, 22 CH

Function	7 CH	10 CH	14 CH	22 CH
Show	1			
Show Speed	2			
Sound Settings	3			
Tilt Rotation Speed (Left)	4			
Tilt Rotation Speed (Right)	5			
Pan	6			
Pan rotation	7			
Dimmer, Zone 1-4		1	1	1
Strobe, Zone 1-4		2	2	2
Red, Zone 1-4		3		
Green, Zone 1-4		4		
Blue, Zone 1-4		5		
White, Zone 1-4		6		
Red, Zone 1-2			3	
Red, Zone 3-4			4	
Green, Zone 1-2			5	
Green, Zone 3-4			6	
Blue, Zone 1-2			7	
Blue, Zone 3-4			8	
White, Zone 1-2			9	
White, Zone 3-4			10	
Red, Zone 1				3
Red, Zone 3				4
Green, Zone 1				5
Green, Zone 3				6
Blue, Zone 1				7
Blue, Zone 3				8
White, Zone 1				9
White, Zone 3				10
Red, Zone 2				11
Red, Zone 4				12
Green, Zone 2				13
Green, Zone 4				14
Blue, Zone 2				15
Blue, Zone 4				16
White, Zone 2				17
White, Zone 4				18
Tilt Rotation Speed (Left)		7	11	19
Tilt Rotation Speed (Right)		8	12	20
Pan		9	13	21
Pan rotation		10	14	22

6.7.2. DMX Channels Overview 28 CH

Function	28 CH
Dimmer, Zone 1	1
Strobe, Zone 1	2
Red, Zone 1	3
Green, Zone 1	4
Blue, Zone 1	5
White, Zone 1	6
Dimmer, Zone 3	7
Strobe, Zone 3	8
Red, Zone 3	9
Green, Zone 3	10
Blue, Zone 3	11
White, Zone 3	12
Dimmer, Zone 2	13
Strobe, Zone 2	14
Red, Zone 2	15
Green, Zone 2	16
Blue, Zone 2	17
White, Zone 2	18
Dimmer, Zone 4	19
Strobe, Zone 4	20
Red, Zone 4	21
Green, Zone 4	22
Blue, Zone 4	23
White, Zone 4	24
Tilt Rotation Speed (Left)	25
Tilt Rotation Speed (Right)	26
Pan	27
Pan rotation	28

6.7.3. 7 CH (7 Channels)

Figure 11

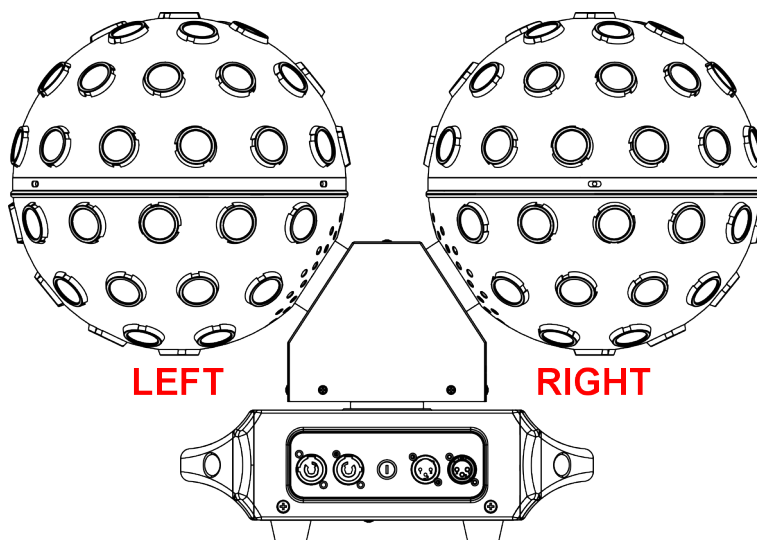

7 CH	Function	Value	Setting
1	Show	000	Blackout
		001-016	Show 0
		017-033	Show 1
		034-050	Show 2
		051-067	Show 3
		068-084	Show 4
		085-101	Show 5
		102-118	Show 6
		119-135	Show 7
		136-152	Show 8
		153-169	Show 9
		170-186	Show 10
		187-203	Show 11
		204-220	Show 12
221-237	Show 13		
238-255	Show 14		
2	Show Speed	000-255	Speed, from slow to fast
3	Sound Settings	000-015	Off
		016-255	Sound-controlled + Sensitivity (low to high)
4	Tilt Rotation Speed (Left)	000-015	Stop
		016-134	Clockwise rotation, from fast to slow
		135-255	Counterclockwise rotation, from slow to fast
5	Tilt Rotation Speed (Right)	000-015	Stop
		016-134	Clockwise rotation, from fast to slow
		135-255	Counterclockwise rotation, from slow to fast
6	Pan	000-255	Pan adjustment 0-360°
7	Pan Rotation	000-015	Stop
		016-134	Clockwise rotation, from fast to slow
		135-255	Counterclockwise rotation, from slow to fast

6.7.4. 10 CH (10 channels), 14 CH (14 Channels), 22 CH (22 Channels)

Figure 12

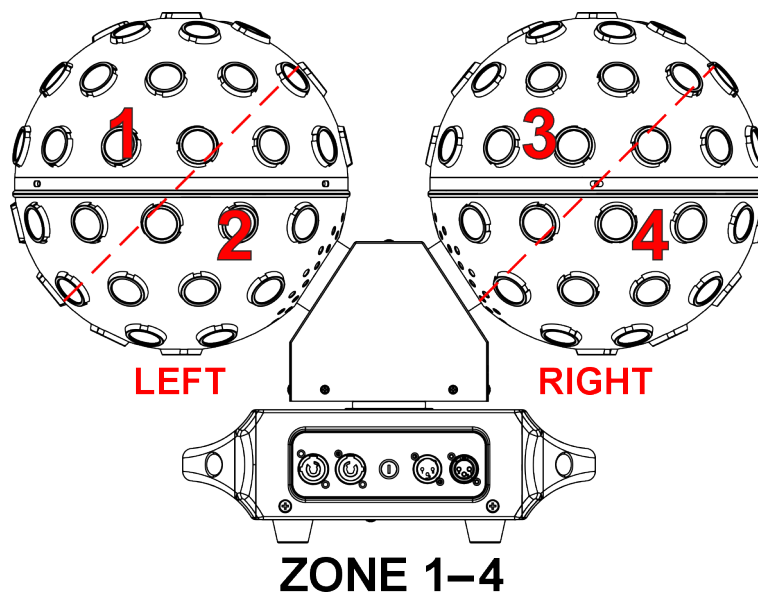

10 CH	14 CH	22 CH	Function	Value	Setting
1	1	1	Dimmer, Zone 1-4	000-255	From low to high intensity (0-100 %)
2	2	2	Strobe, Zone 1-4	000-009	No function
				010-110	Strobe, from low to high frequency
				111-115	No function
				116-182	Pulse strobe, from low to high frequency
				183-187	No function
				188-255	Random strobe, from low to high frequency
3			Red, Zone 1-4	000-255	From low to high intensity (0-100 %)
4			Green, Zone 1-4	000-255	From low to high intensity (0-100 %)
5			Blue, Zone 1-4	000-255	From low to high intensity (0-100 %)
6			White, Zone 1-4	000-255	From low to high intensity (0-100 %)
	3		Red, Zone 1-2	000-255	From low to high intensity (0-100 %)
	4		Red, Zone 3-4	000-255	From low to high intensity (0-100 %)
	5		Green, Zone 1-2	000-255	From low to high intensity (0-100 %)
	6		Green, Zone 3-4	000-255	From low to high intensity (0-100 %)
	7		Blue, Zone 1-2	000-255	From low to high intensity (0-100 %)
	8		Blue, Zone 3-4	000-255	From low to high intensity (0-100 %)
	9		White, Zone 1-2	000-255	From low to high intensity (0-100 %)
	10		White, Zone 3-4	000-255	From low to high intensity (0-100 %)
		3	Red, Zone 1	000-255	From low to high intensity (0-100 %)
		4	Red, Zone 3	000-255	From low to high intensity (0-100 %)
		5	Green, Zone 1	000-255	From low to high intensity (0-100 %)
		6	Green, Zone 3	000-255	From low to high intensity (0-100 %)
		7	Blue, Zone 1	000-255	From low to high intensity (0-100 %)
		8	Blue, Zone 3	000-255	From low to high intensity (0-100 %)
		9	White, Zone 1	000-255	From low to high intensity (0-100 %)
		10	White, Zone 3	000-255	From low to high intensity (0-100 %)
		11	Red, Zone 2	000-255	From low to high intensity (0-100 %)
		12	Red, Zone 4	000-255	From low to high intensity (0-100 %)

		13	Green, Zone 2	000–255	From low to high intensity (0–100 %)
		14	Green, Zone 4	000–255	From low to high intensity (0–100 %)
		15	Blue, Zone 2	000–255	From low to high intensity (0–100 %)
		16	Blue, Zone 4	000–255	From low to high intensity (0–100 %)
		17	White, Zone 2	000–255	From low to high intensity (0–100 %)
		18	White, Zone 4	000–255	From low to high intensity (0–100 %)
7	11	19	Tilt Rotation Speed (Left)	000–015	Stop
				016–134	Clockwise rotation, from fast to slow
				135–255	Counterclockwise rotation, from slow to fast
8	12	20	Tilt Rotation Speed (Right)	000–015	Stop
				016–134	Clockwise rotation, from fast to slow
				135–255	Counterclockwise rotation, from slow to fast
9	13	21	Pan	000–255	Pan adjustment 0–360°
10	14	22	Pan rotation	000–015	Stop
				016–134	Clockwise rotation, from fast to slow
				135–255	Counterclockwise rotation, from slow to fast

6.7.5. 28 CH (28 Channels)

Figure 13

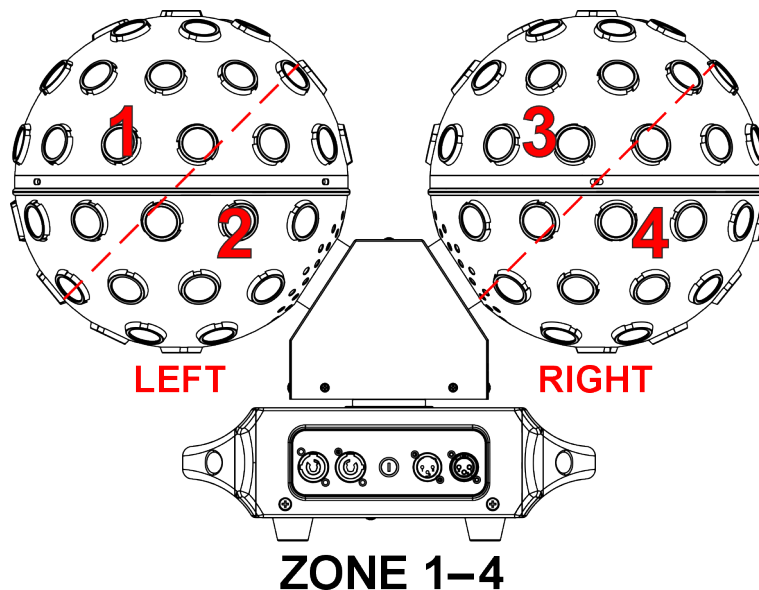

ZONE 1-4

28 CH	Function	Value	Setting
1	Dimmer, Zone 1	000-255	From low to high intensity (0-100 %)
2	Strobe, Zone 1	000-009	No function
		010-110	Strobe, from low to high frequency
		111-115	No function
		116-182	Pulse strobe, from low to high frequency
		183-187	No function
		188-255	Random strobe, from low to high frequency
3	Red, Zone 1	000-255	From low to high intensity (0-100 %)
4	Green, Zone 1	000-255	From low to high intensity (0-100 %)
5	Blue, Zone 1	000-255	From low to high intensity (0-100 %)
6	White, Zone 1	000-255	From low to high intensity (0-100 %)
7	Dimmer, Zone 3	000-255	From low to high intensity (0-100 %)
8	Strobe, Zone 3	000-009	No function
		010-110	Strobe, from low to high frequency
		111-115	No function
		116-182	Pulse strobe, from low to high frequency
		183-187	No function
		188-255	Random strobe, from low to high frequency
9	Red, Zone 3	000-255	From low to high intensity (0-100 %)
10	Green, Zone 3	000-255	From low to high intensity (0-100 %)
11	Blue, Zone 3	000-255	From low to high intensity (0-100 %)
12	White, Zone 3	000-255	From low to high intensity (0-100 %)
13	Dimmer, Zone 2	000-255	From low to high intensity (0-100 %)
14	Strobe, Zone 2	000-009	No function
		010-110	Strobe, from low to high frequency
		111-115	No function
		116-182	Pulse strobe, from low to high frequency
		183-187	No function
		188-255	Random strobe, from low to high frequency
15	Red, Zone 2	000-255	From low to high intensity (0-100 %)
16	Green, Zone 2	000-255	From low to high intensity (0-100 %)
17	Blue, Zone 2	000-255	From low to high intensity (0-100 %)
18	White, Zone 2	000-255	From low to high intensity (0-100 %)

19	Dimmer, Zone 4	000–255	From low to high intensity (0–100 %)
20	Strobe, Zone 4	000–009	No function
		010–110	Strobe, from low to high frequency
		111–115	No function
		116–182	Pulse strobe, from low to high frequency
		183–187	No function
		188–255	Random strobe, from low to high frequency
21	Red, Zone 4	000–255	From low to high intensity (0–100 %)
22	Green, Zone 4	000–255	From low to high intensity (0–100 %)
23	Blue, Zone 4	000–255	From low to high intensity (0–100 %)
24	White, Zone 4	000–255	From low to high intensity (0–100 %)
25	Tilt Rotation Speed (Left)	000–015	Stop
		016–134	Clockwise rotation, from fast to slow
		135–255	Counterclockwise rotation, from slow to fast
26	Tilt Rotation Speed (Right)	000–015	Stop
		016–134	Clockwise rotation, from fast to slow
		135–255	Counterclockwise rotation, from slow to fast
27	Pan	000–255	Pan adjustment 0–360°
28	Pan rotation	000–015	Stop
		016–134	Clockwise rotation, from fast to slow
		135–255	Counterclockwise rotation, from slow to fast

6.8. RDM Information

This device supports RDM (see [6.8.2. Supported RDM PIDs \(Parameter IDs\)](#)).

6.8.1. RDM Details

- Responder ID: 29B4:10Cxxxxx
- Manufacturer's ID: Showtec (Highlite International B.V.)
- Manufacturer Label: Showtec
- Model Description: FireBall PRO
- Model ID: 268 (10C hexadecimal)
- Device Label: FireBall PRO

Note:

An RDM responder ID consists of 3 parts:

- 1st part – 4 digits – Manufacturer's ID
- 2nd part – 3 digits – Model ID
- 3rd part – 5 digits – Unique ID

The RDM responder IDs of all products of Highlite International start with the same 4 digits. The first 7 digits of the RDM responder ID for each model are the same. The last 5 digits are different for each device.

6.8.2. Supported RDM PIDs (Parameter IDs)

RDM Parameter ID	Value	Required	GET	SET
SUPPORTED_PARAMETERS	0x0050	*	*	
DEVICE_MODEL_DESCRIPTION	0x0080		*	
MANUFACTURER_LABEL	0x0081		*	
DEVICE_LABEL	0x0082		*	*
DMX_PERSONALITY	0x00E0		*	*
DMX_PERSONALITY_DESCRIPTION	0x00E1		*	
DMX_START_ADDRESS	0x00F0	*	*	*
SENSOR_DEFINITION	0x0200		*	
SENSOR_VALUE	0x0201		*	*
RECORD_SENSORS	0x0202			*
DEVICE_HOURS	0x0400		*	*

7. Troubleshooting

This troubleshooting guide contains solutions to problems which can be carried out by an ordinary person. The device does not contain user-serviceable parts.

Unauthorized modifications to the device will render the warranty void. Such modifications may result in injuries and material damage.

Refer servicing to instructed or skilled persons. Contact your Highlite International dealer in case the solution is not described in the table.

Problem	Probable cause(s)	Solution
The device does not function at all	No power to the device	<ul style="list-style-type: none"> Make sure that the device is connected to power supply and the cables are plugged in
	The LEDs are defective	<ul style="list-style-type: none"> Contact your Showtec dealer
The device responds erratically	The factory settings of the device are changed	<ul style="list-style-type: none"> Reset the parameters of the device to the default factory settings (see 6.6.7. Special Functions on page 28)
The device does not respond to DMX control	The controller is not connected	<ul style="list-style-type: none"> Check if the fixture is connected to the controller
	The signal is reversed. The 3-pin DMX Out of the controller does not match the DMX In of the device	<ul style="list-style-type: none"> Install a phase-reversing cable between the controller and the device
	The controller is defective	<ul style="list-style-type: none"> Try using another controller
The device responds erratically to DMX control	Connections are defective	<ul style="list-style-type: none"> Examine connections and cables. Correct defective connections. Repair or replace damaged cables
	The data link is not terminated with a 120 Ω termination plug	<ul style="list-style-type: none"> Insert a termination plug in the DMX OUT connector of the last device on the link
	Incorrect addressing	<ul style="list-style-type: none"> Make sure that the address settings are correct (see 6.6.1.1. DMX Address on page 23)
	In case of a setup with multiple devices, one of the devices is defective and disturbs data transmission on the link	<ul style="list-style-type: none"> To find out the defective device, bypass one device at a time until normal operation is restored
No light or LEDs cut out intermittently	LEDs are damaged	<ul style="list-style-type: none"> Disconnect the device and contact your Highlite International International dealer
	The input power parameters of the device do not match the local AC voltage and frequency	<ul style="list-style-type: none"> Disconnect the device. Make sure that the local current, voltage and frequency match the input voltage, current and frequency specified on the information label on the device

8. Maintenance

8.1. Safety Instructions for Maintenance



DANGER
Electric shock caused by dangerous voltage inside

Disconnect power supply before servicing or cleaning.

8.2. Preventive Maintenance



Attention
Before each use, examine the device visually for any defects.

Make sure that:

- There are no deformations on housings, fixings and installation points.
- The power cables are not damaged and do not show any material fatigue.

8.2.1. Basic Cleaning Instructions

To clean the device, follow the steps below:

- 01) Disconnect the device from the electrical power supply.
- 02) Allow the device to cool down for at least 5 minutes.
- 03) Clean the device with a soft, lint-free cloth.



Attention

- Do not immerse the device in liquid.
- Do not use alcohol or solvents.

8.3. Corrective Maintenance

The device does not contain user-serviceable parts. Do not open the device and do not modify the device.

Refer repairs and servicing to instructed or skilled persons. Contact your Highlite International dealer for more information.

8.3.1. Replacing the Fuse



DANGER
Electric shock caused by short-circuit

- Do not bypass the thermostatic switch or fuses.
- Replace fuses only with the same type and rating.

Power surges, short-circuit or incorrect electrical power supply may cause a fuse to burn out. If the fuse burns out, the device will not function anymore. If this happens, follow the steps below:

- 01) Disconnect the device from the electrical power supply.
- 02) Allow the device to cool down for at least 15 minutes.
- 03) Loosen the fuse cover with a screwdriver and remove the fuse holder.
- 04) If the fuse is brown or unclear, it is burned out. Remove the old fuse.
- 05) Insert a new fuse in the fuse holder. Make sure that the type and the rating of the replacement fuse are the same as the ones specified on the information label of the product.
- 06) Replace the fuse holder in the opening and tighten the fuse cover.

9. Deinstallation, Transportation and Storage

9.1. Instructions for Deinstallation



WARNING

Incorrect deinstallation can cause serious injuries and damage of property.

- Let the device cool down before dismantling.
- Disconnect power supply before deinstallation.
- Always observe the national and site-specific regulations during deinstallation and derigging of the device.
- Wear personal protective equipment in compliance with the national and site-specific regulations.

9.2. Instructions for Transportation

- Use the original packaging to transport the device, if possible.
- Always observe the handling instructions printed on the outer carton box, for example: "Handle with care", "This side up", "Fragile".

9.3. Storage

- Clean the device before storing (see [8.2.1. Basic Cleaning Instructions](#) on page 38).
- Store the device in the original packaging, if possible.

10. Disposal

Correct disposal of this product



Waste Electrical and Electronic Equipment

This symbol on the product, its packaging or documents indicates that the product shall not be treated as household waste. Dispose of this product by handing it to the respective collection point for recycling of electrical and electronic equipment. This is to avoid environmental damage or personal injury due to uncontrolled waste disposal. For more detailed information about recycling of this product contact the local authorities or the authorized dealer.

11. Approval



Check the respective product page on the website of Highlite International (www.highlite.com) for an available declaration of conformity.

