



BERLIN

NUMERIC OSCILLATOR

Model of 1989

Wide-range VCO (20+ octaves of tracking) · Interface for Leibniz Binary Subsystem · Square and Saw waves that can be digitally waveshaped with no aliasing · Turns Jena into a vintage-style wavetable oscillator · Turns Rostock into a metallic noise and glitchy oscillator · Agile signal link input for mutating waves · CV inputs for octave switching and hard sync · Ultrasonic clock source



XAOC DEVICES SP. Z O. O.
WORKING CLASS ELECTRONICS
MADE IN THE EUROPEAN UNION
WWW.XAOCDEVICES.COM



MODULE INSTALLATION

Salut! Thank you for purchasing this Xaoc Devices product. Berlin is a compact VCO (voltage controlled oscillator) with a very wide tracking range (over 20 octaves) and unusual waveforming capabilities. Berlin features a Leibniz interface allowing it to be connected to modules from the Leibniz Binary Subsystem, a family of 8-bit signal processing devices offering comprehensive manipulation of signals and voltages in the digital domain. Berlin can work as a plain VCO, without any Leibniz devices connected. On its own, it offers square and sawtooth waves.

When you add Berlin to a Leibniz setup, your whole subsystem becomes a (possibly complex) oscillator with a huge palette of unusual waveforms that may be periodic, quasi-random, robotic, glitchy, etc., with its sonic characteristics preserved even when played melodically. Note: Berlin does not need Drezno to perform its waveshaping, as the conversion between digital and analog is already built in. Berlin also sports a dedicated output for its clock signal—operating at a frequency 256 times higher than the pitch frequency of Berlin's analog waves; it can easily reach the MHz range while still preserving proper V/oct tracking.

To better understand the device and avoid common pitfalls we strongly advise the user to read through the entire manual before using the module.

INSTALLATION

Berlin requires 8hp worth of free space in the Eurorack cabinet. Always turn the power off before plugging the module into the bus board using the supplied 16-wire ribbon cable, paying close attention to power cable pinout and orientation. The red stripe indicates the negative rail and should match the arrowhead or **-12V** mark on the bus board as well as the unit.

Berlin is internally secured against reversed power connection; however, flipping the 16-pin header may cause serious damage to other components of your system because it will short-circuit the +12V and +5V power lines.

For connecting to other Leibniz modules that will transform the wave (e.g., Jena, Rostock, Gera, Erfurt, Poczdam, etc.), use the data ribbon cable included with your Berlin, as well as the data cable

included with the other module. Connect the **OUT**-header of Berlin to the **IN** header of your other Leibniz module. Connect the **OUT** header of that module back to the **IN** header of Berlin. If you have more Leibniz modules you may set them up in a chain.

AVOID PLUGGING OUT TO OUT! Observe the arrow indicators of pin #1 on the Leibniz header of each module (not always pointing in the same direction). Note: incorrectly plugged cables will result in entirely erroneous operation.

WARNING: Never plug power to the 10-pin Leibniz data headers, this would heavily damage your Berlin and jeopardize other modules connected to it.

The module should be fastened by mounting the supplied screws before powering up.

MODULE OVERVIEW

Berlin features a straightforward interface (see fig. 1) similar to classic VCOs. The central big **PITCH** knob ① offers continuous manual fine tuning in the range of ± 1 octave (except when in LFO mode that allows for a ± 5 octave sweep). The octave register/range is selected by a pair of **OCT DWN** and **OCT UP** buttons ② and indicated with a bar of LEDs ③. Additionally, the octaves may be switched by a CV plugged to the **OCT SELECT** jack ④ which reacts to 1V increments in the range of -5V to +5V. There is a **PITCH CV** V/oct input for pitch control voltages ⑤ that accepts voltages in the -5V to +10V range, and an additional **FM** CV input ⑥ for exponential pitch control with a dedicated manual attenuator knob ⑦.

NOTE: the actual range of accepted voltages depends on the combined values of all controls. For example, with +10V plugged into the 1V/oct input it may not be possible to go any higher with the **PITCH** knob or the **FM** input.

The signals produced by Berlin are available at the outputs in the bottom row. The **SAW-LBZ WAVE** jack ⑧ is the main output. It delivers either a rising saw wave (sometimes called a ramp), or a wave transformed by the Leibniz modules connected at the back.

Switching between these two is possible using the blue backlit button ⑨ and the associated **LBZ LINK** input jack ⑩, which accepts 5V gate and logic sig-

PRINCIPLE OF OPERATION

nals. The switching happens instantly and may be activated at extreme rates allowing for all types of output wave mutations.

The **SQUARE** output **11** delivers a perfectly symmetric square wave (in other words, a rectangle wave with 50% pulse width), regardless of which wave is selected for the **SAW·LBZ WAVE** output. Both these waves are 10Vpp bipolar, and they maintain their shape and amplitude throughout the entire audio range and beyond.

The generation of the **SAW·LBZ** waves as well as the **SQUARE** wave may be interrupted by syncing to some other oscillator source. The **HARD SYNC** input **12** accepts all types of signals and resets the currently produced cycle of the wave each time the

sync signal crosses a fixed 2.4V threshold.

The **LBZ CLOCK** output **13** offers a digital signal (5V logic) 256 times faster than the current pitch frequency of the VCO. In other words, it is a high frequency clock that can easily go into the MHz range while still following the 1V/oct tracking. Note that this clock is not interrupted by the **SYNC** input.

THE PRINCIPLE OF OPERATION

Berlin is a hybrid analog/digital oscillator. An important detail regarding its digital part is that unlike the majority of wavetable oscillators it doesn't produce signals by resampling a stored digital wave with a constant sampling frequency and different phase increment. Instead, it varies the clock frequency within the entire tuning range and generates all sample values of the waveform with appropriate rate to obtain the desired pitch, so there are no skipped points on the curve (fig. 2).

Resampling results in waveforms either containing increasing amount of aliasing at higher pitches, or missing important details and sounding dull (as a result of anti-aliasing). Thanks to its approach, Berlin generates signals with great tone richness and full spectrum without aliasing, similarly to famous digital synthesizers from the 1980s, such as Fairlight CMI or PPG Wave.

The heart of Berlin (fig. 3) is an oscillator core operating at super high frequency but only within one octave, followed by a multi-stage octave-down divider. Thus, a corresponding tone and octave can be selected depending on the desired operating frequency, and a high frequency clocking signal is produced with uniform tracking accuracy within the entire range of tuning.

This clock is then driving a sample counter which is a source of a digital ramp (a repeating sequence of binary numbers from 0 to 255). The ramp is passed to the DAC (digital-to-analog converter) and produces a rising saw signal from -5V to +5V. While this is not a perfectly smooth wave, no samples are dropped regardless of the pitch. Hence, there are no alien spectral components resulting from interference with the sampling frequency, also known as aliasing. The only side effects are perfect additional harmonics eight octaves above

fig. 1: BERLIN FRONT PANEL LAYOUT AND CONTROLS

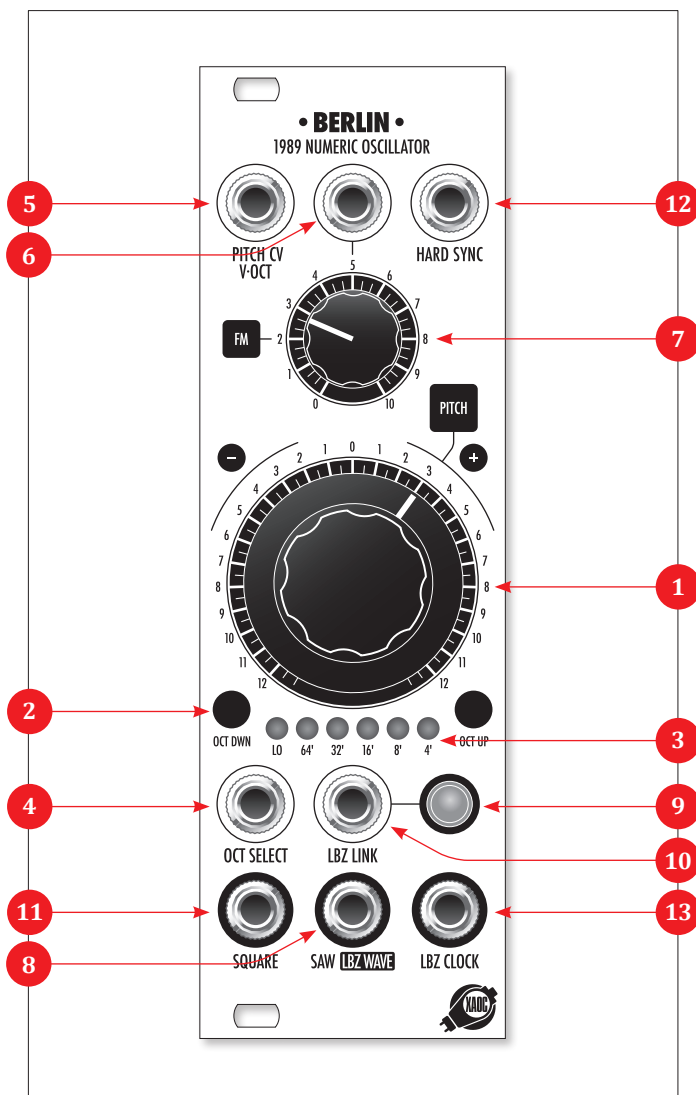

PITCH CONTROL

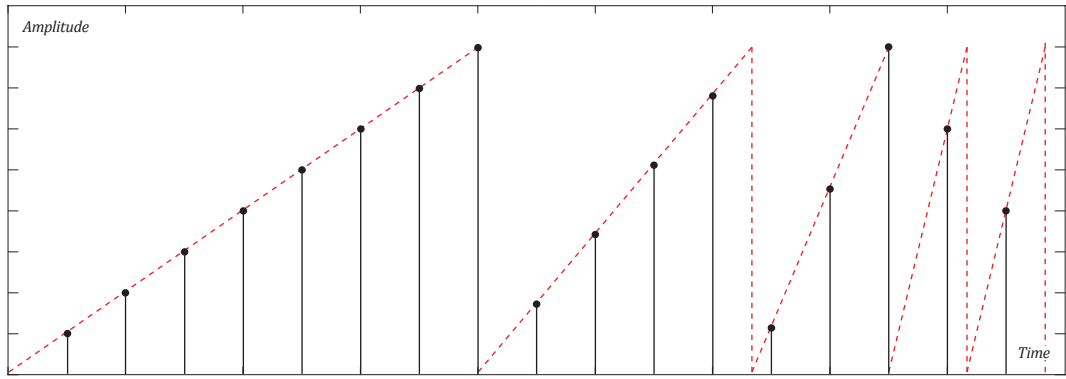

fig. 2a: CHANGING PITCH OF GENERATED WAVE VIA RESAMPLING

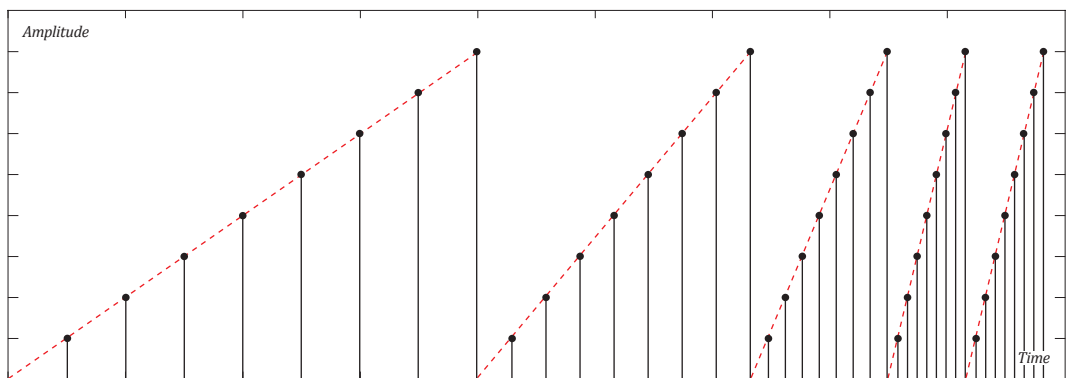

fig. 2b: CHANGING PITCH OF GENERATED WAVE VIA VARYING SAMPLE CLOCK

the fundamental frequency. Note that for pitch frequencies above 62.5Hz these harmonics are beyond the range of human hearing.

The square signal is generated from the most significant bit of the counter output. Thus it is guaranteed to have a 50% duty cycle in the entire tuning range, and offers a recognizable pure hollow sound with only odd harmonics.

The **HARD SYNC** input allows for resetting the wave cycle at any point. It features a comparator to reliably handle external syncing signals even if they don't have sharp edges. Once the external signal crosses the threshold, the counter is instantly reset to zero thus restarting the digital ramp from the beginning of the cycle. Note that this corresponds to -5V at the analog output.

PITCH CONTROL

Berlin can operate in the entire range of audible frequencies and beyond. The pitch frequency is controlled from the front panel with the central Pitch knob and a pair of **OCT UP** and **OCT DWN** but-

tons switching the current octave between 64' and 4', which is indicated by one of the red LEDs in the indicator bar. Within these five settings, the **PITCH** knob offers continuous fine tune with a range of ± 12 semitones. The lowest **LO** position of the range switch engages the LFO mode indicated by a yellow LED. The LFO mode allows one to reach sub-Hz frequencies (down to 30secs per cycle). In this mode, the **PITCH** knob offers ± 5 octaves of sweep.

Besides the panel controls, the pitch frequency can also be controlled with CV. The calibrated V/oct input accepts voltages from -5V to +10V, while the attenuated exponential **FM** input accepts ± 5 V of modulation. Together with the **PITCH** knob, they jointly offer a range of 15 octaves. On top of that 15-octave limit, the octave controls add additional 5. Besides the manual buttons, octaves can also be shifted with CV.

The **OCT SELECT** input is quantized to 1V steps. Since this feature is implemented using a frequency divider, the switching results in perfect octave steps.

BLOCK DIAGRAM

WAVESHAPING WITH LEIBNIZ MODULES

Before driving the DAC, the digital ramp data generated in Berlin may be optionally processed by modules from the Leibniz Binary Subsystem connected to the **IN** and **OUT** headers at the back. For example, combining Berlin with Jena module by Xaoc Devices creates a 1980's-style wavetable oscillator with thru-zero phase modulation, hard sync, and voltage sweeping through all the wave banks of Jena.

In such a setup, the values of the ramp from Berlin are mapped through the currently selected shape in Jena. This causes all values from the shape to be read in a cycle; these values are returned to Berlin, and finally converted to an analog signal.

While Jena is a good example of straightforward waveshaping, you are not limited to just the instantaneous nonlinearity it offers. The Leibniz clock signal passed along with the data will effectively scale the temporal structure of the output of any of your Leibniz patches, thus yielding a signal that follows your pitch CV.

You can pass the data from Berlin through a combination of Leibniz modules which may contain mem-

ory or delay, and even some binary feedback loops.

Such a loop may be offered by the modules internally (e.g., Xaoc Devices Rostock – with its **SCRAMBLE** function), or it may be created using patch cables plugged between some downstream bit outputs to inputs in earlier elements of your subsystem. This often yields pseudo-chaotic behavior and translates to complex, glitchy, and metallic noise signals generated from Berlin.

THE CLOCK SIGNAL

Besides the **SAW-LBZ WAVE** and the **SQUARE** waveforms, Berlin outputs a high frequency clock signal. As its frequency is 256 times the pitch frequency of the output waveforms, it can easily go into the MHz range and can be exploited in patches requiring such ultrasonic drive. To name a few: direct clocking of BBD delays and other delay lines, driving switched capacitor filters, clocking sub-octave frequency dividers.

Note that not every device accepts the highest frequencies Berlin's clock is capable of. Also, remember that standard Eurorack patch cables have quite a limited bandwidth not always suitable for such high frequencies.

fig. 3: INTERNAL STRUCTURE OF BERLIN

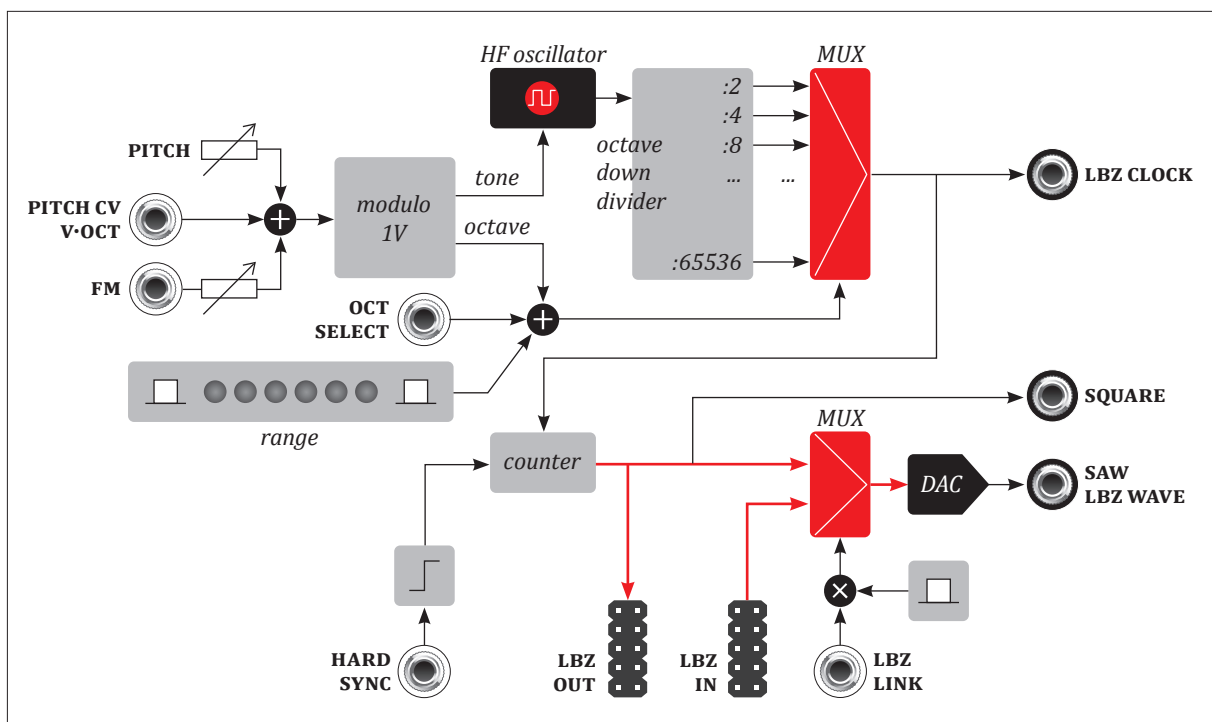

USING RAMP GENERATOR AND WAVE DAC INDEPENDENTLY

Similarly to Xaoc Devices Drezno, Berlin may be considered as consisting of two nearly independent parts: one that generates the Leibniz data, and one that receives it and converts it to an analog signal. You can even use the two parts of Berlin interchangeably with the corresponding two parts of Drezno.

Within Berlin, its two parts may be patched entirely independently. For example, the data source part operating in LFO mode may be employed in a rhythm generation setup (eg. with Jena), while the DAC may be producing sequenced control voltages from data generated by Xaoc Devices Ostankino II (relaying the 8-bit representation of Moskwa II's CV potentiometers' positions—use the **SAW·LBZ WAVE** output).

NOTE: unlike Drezno, the DAC in Berlin is actually an asynchronous device and it doesn't require clock to be delivered together with the data. It reacts almost instantaneously (with a 1µsec settling time) to any change on its binary inputs. That means it can also convert to analog any static data coming from clockless modules, such as Xaoc Devices Lipsk.

PATCH IDEAS

- By using the **LBZ LINK** input you can instantly switch between the original saw and the transformed signal (e.g., the Jena wave). This can be used to mutate the shape during each cycle, or after a number of cycles. For example, patching the **SQUARE** output signal to the **LINK** input will cause switching the waveshape in half of the cycle. Pressing the button selects which of the halves is the transformed one. Extending this patch by using the **SQUARE** signal processed with a frequency divider may create more textured sounds, because the wave shape will be switched after a number of cycles.
- By connecting Berlin to Rostock, you can generate a broad range of complex signals by engaging the **LOOP** and **SCRAMBLE** features, and modulating the length of the pipeline in Rostock. Observe that unusual waves occur when the length is not an integer power of 2 because it interferes with the length of the input ramp which is 256. Operating the **RESET** button in Rostock spawns a different sound each time, because it initiates the pseudo-chaotic generator at a different phase point of the ramp.

- The previous patch is a source of signals wildly different from the common VCO waves. More subtle effects can be achieved by constraining the chaotic effects to lowest bits. Replace the Berlin+Rostock setup with a chain of Berlin into Lipsk into Rostock into Jena (and back to Berlin). Disengage the **LOOP** function in Rostock. Instead, make your own loops by patching from some of the **BIT OUTPUTS** in Jena to the (lowest) **BIT INPUTS** in Lipsk.

- Use the **LBZ CLK OUT** to drive Xaoc Devices Erfurt via its front panel, but do not connect Berlin to its Leibniz **IN**. Patch some divided frequencies from Erfurt to a simple mixer. Adjusting the amplitude of different octaves and applying a lowpass filter after the mixer should result in a whole palette of cliché electronic organ sounds.

- Setting Berlin to LFO range allows it to control the rhythms from the bank E of Jena. Use the asynchronous regime of Jena (display showing **OFF**). The playback can be synced to an external rhythm clock with Berlin's Hard Sync feature (**NOTE:** there is no tap-tempo functionality, the sync simply re-starts the cycle).

- Two Berlin oscillators may be combined with Xaoc Devices Poczdam in a patch that produces sounds hardly available outside of the Leibniz realm. The idea is to switch between two data streams synchronously with the wave cycle. For this to work effectively you need to patch the **SQUARE** signal from one of the Berlin units to the **SELECT** input of Poczdam, and use the same signal to sync the second Berlin. Connect Leibniz **OUT** headers of both your Berlin units to the inputs of Poczdam, and connect the **OUT** of Poczdam to **IN** of one of the Berlin units.

CONNECTIVITY

With the provided Leibniz data cables, Berlin connects to all modules compatible with the Leibniz Binary Subsystem: Lipsk, Gera, Jena, Erfurt, Poczdam, Rostock, Drezno, Drezno II, Ostankino II, and Odessa.

ACCESSORY

Our Coal Mine black panels are available for all of the Xaoc Devices modules. Sold separately. Ask your favorite retailer. •

**TECHNICAL
SPECIFICATION**

WIDTH	DEPTH TOTAL	CURRENT DRAW	REV. POWER PROTECT.
8hp	30mm	+40mA -20mA	protected

INPUTS		OUTPUTS	
PITCH CV	-10V to +10V; 1V/octave	SQUARE	-5V to +5V
FM	-5V to +5V	SAW-LBZ WAVE	-5V to +5V
HARD SYNC	+2.4V input threshold	LBZ CLOCK	+5V digital
OCT SELECT	-5V to +5V		
LBZ LINK	+5V standard gate		

FREQUENCY RANGE	
waveform frequency range	0.03125Hz (30 sec cycle) to 250kHz
maximum usable clock frequency	20MHz

ALL RIGHTS RESERVED. CONTENT COPYRIGHT ©2023 XAOC DEVICES. COPYING, DISTRIBUTION, OR COMMERCIAL USE IN ANY WAY IS STRICTLY PROHIBITED AND REQUIRES WRITTEN PERMISSION FROM XAOC DEVICES. SPECIFICATIONS ARE SUBJECT TO CHANGE WITHOUT PRIOR NOTICE. EDITING BY BRYAN NOLL. **WARRANTY TERMS:** XAOC DEVICES WARRANTS THIS PRODUCT TO BE FREE OF DEFECTS IN MATERIALS OR WORKMANSHIP AND TO CONFORM WITH THE SPECIFICATIONS AT THE TIME OF SHIPMENT FOR ONE YEAR FROM THE DATE OF PURCHASE. DURING THAT PERIOD, ANY MALFUNCTIONING OR DAMAGED UNITS WILL BE REPAIRED, SERVICED, AND CALIBRATED ON A RETURN-TO-FACTORY BASIS. THIS WARRANTY DOES NOT COVER ANY PROBLEMS RESULTING FROM DAMAGES DURING SHIPPING, INCORRECT INSTALLATION OR POWER SUPPLY, IMPROPER WORKING ENVIRONMENT, ABUSIVE TREATMENT, OR ANY OTHER OBVIOUS USER-INFLECTED FAULT. **LEGACY SUPPORT:** IF SOMETHING GOES WRONG WITH A XAOC PRODUCT AFTER THE WARRANTY PERIOD IS OVER, THERE IS NO NEED TO WORRY, AS WE ARE STILL HAPPY TO HELP! THIS APPLIES TO ANY DEVICE, WHEREVER AND WHENEVER ORIGINALLY ACQUIRED. HOWEVER, IN SPECIFIC CASES, WE RESERVE THE RIGHT TO CHARGE FOR LABOR, PARTS, AND TRANSIT EXPENSES WHERE APPLICABLE. **RETURN POLICY:** THE DEVICE INTENDED FOR REPAIR OR REPLACEMENT UNDER WARRANTY NEEDS TO BE SHIPPED IN THE ORIGINAL PACKAGING ONLY AND MUST INCLUDE A COMPLETED RMA FORM. XAOC DEVICES CAN NOT TAKE ANY RESPONSIBILITY FOR DAMAGES CAUSED DURING TRANSPORT. SO BEFORE SENDING US ANYTHING, PLEASE CONTACT US AT SUPPORT@XAOCDEVICES.COM. NOTE THAT ANY UNSOLICITED PARCEL WILL BE REJECTED AND RETURNED! **GENERAL INQUIRIES:** FOR USER FEEDBACK SUGGESTIONS, DISTRIBUTION TERMS, AND JOB POSITIONS, FEEL FREE TO CONTACT XAOC DEVICES AT INFO@XAOCDEVICES.COM. PLEASE VISIT XAOCDEVICES.COM FOR INFORMATION ABOUT THE CURRENT PRODUCT LINE, USER MANUALS AND FIRMWARE UPDATES.



XAOC DEVICES SP. Z O. O.
WORKING CLASS ELECTRONICS
MADE IN THE EUROPEAN UNION
WWW.XAOCDEVICES.COM

