

DW PEDAL WARRANTY

This warranty protects the original retail purchaser for a period of five (5) years from the date of purchase. If a covered product or component fails due to a manufacturing or material defect under normal conditions, Drum Workshop, Inc. will repair or replace the product at no charge. This warranty is limited to cast parts only, such as the base casting, footboard, beater hub, sprocket, heel and cam casting. Moving parts, such as the spring assembly, beater ball, radius rod, hex shaft and ball bearings, are not covered. To obtain warranty service, return the product along with your original proof of purchase to your authorized DW dealer. In the case that the dealer is unable to correct a warranty defect, the dealer will then contact Drum Workshop, Inc. for further instructions and to obtain a Return Authorization (RA) number. No shipments will be accepted without an RA number. Shipping charges are the responsibility of the purchaser.



5-YEAR LIMITED WARRANTY

DRUM WORKSHOP, INC | 3450 LUNAR COURT • OXNARD, CA 93030 USA | WWW.DWDRUMS.COM
SPECIFICATIONS SUBJECT TO CHANGE WITHOUT NOTICE. #PRCADLCP © DW 2018

dw OWNER'S MANUAL

DW 5000 SERIES

Thank you for purchasing this DW product. It has been designed and manufactured to provide a lifetime of trouble-free service. Please take a moment to familiarize yourself with the exclusive features and operating suggestions contained in this manual in order to ensure its optimum performance.

Should you have any further questions, feel free to contact your local authorized DW dealer.

- 5000 Series Cajon Pedal - DWCP5000CJ
- 5000 Series Cajon Direct Link - DWCP5000CJDL

Don Lombardi
— Don Lombardi
Founder, Drum Workshop, Inc.

The Drummer's Choice®

Remove the product, accessories and all packing materials from the box, then follow these instructions to set-up and adjust your pedal to fit the way you play.

DW 5000 SERIES CAJON PEDAL

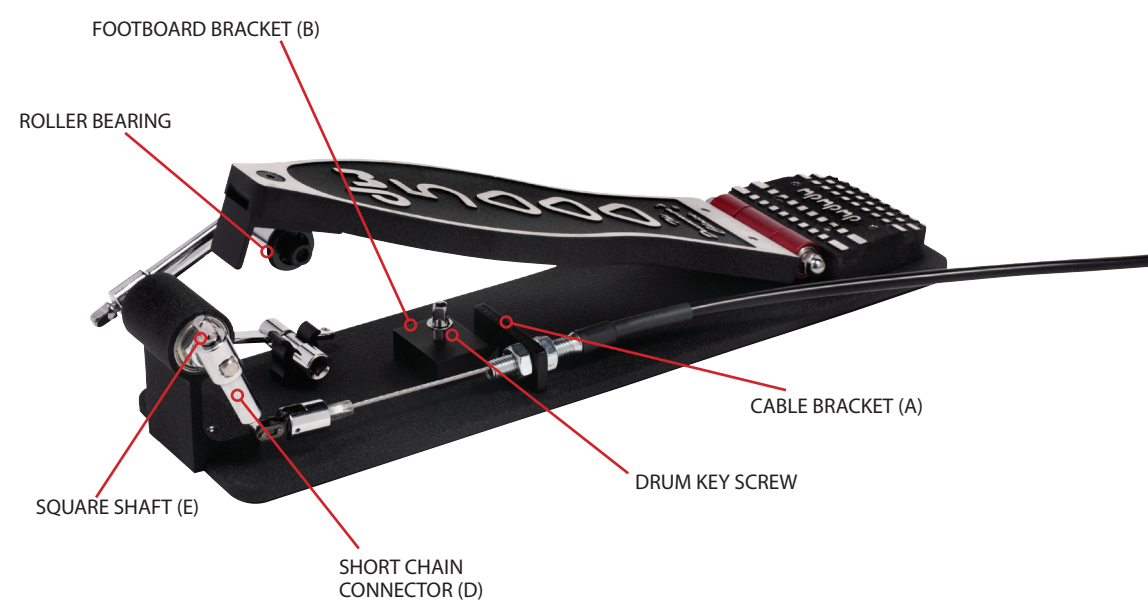

CONNECTING CABLE TO PEDAL PLATE

Note: The footboard is not connected to the roller bearing, the footboard lays on top of the roller bearing.

1. Make sure FOOTBOARD BRACKET (B) drum key screw is loose.
2. Slide CABLE BRACKET (A) all the way into FOOTBOARD BRACKET (B), as shown.
3. Tighten FOOTBOARD BRACKET (B) drum key screw.
4. Slide SHORT CHAIN CONNECTOR (D) onto SQUARE SHAFT (E). You will have to rotate shaft to align the square in proper position (turning shaft will raise the roller bearing and push the footboard up).
5. Tighten key screw from SHORT CHAIN CONNECTOR (D).

CONNECTING CABLE TO THE BEATER MECHANISM ASSEMBLY

1. Insert the HEX CABLE HOLDER (G) into the BEATER MECHANISM ASSEMBLY, and TIGHTEN DRUM KEY SCREW (F) on the flat of the HEX CABLE HOLDER.
2. Slide the LONG CHAIN CONNECTOR (I) onto SQUARE SHAFT (H). You will have to rotate shaft to align the square in proper position.
3. Tighten KEY SCREW (J) on LONG CHAIN CONNECTOR (I).

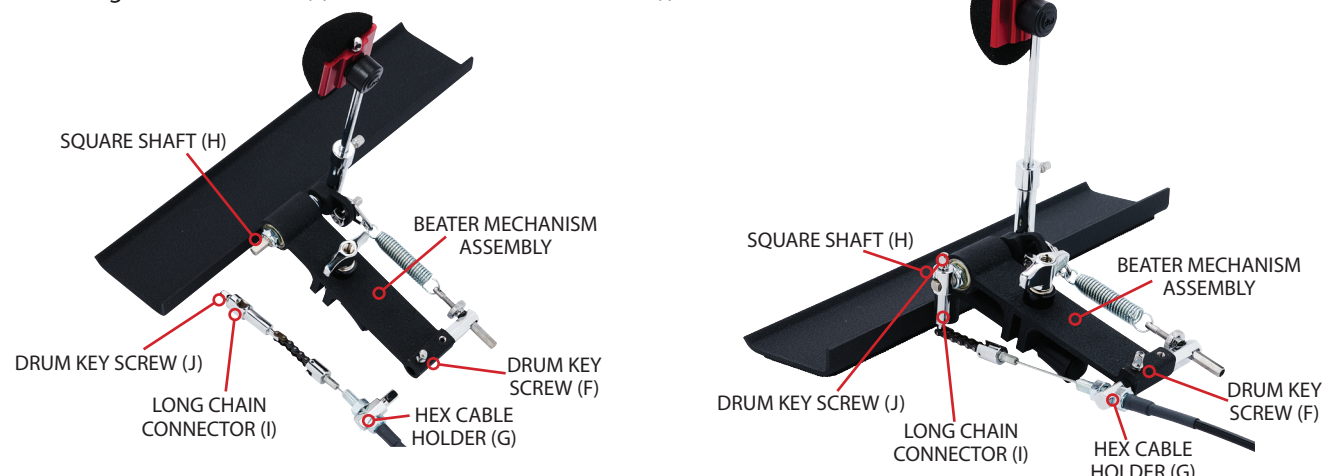

DISCONNECTING CABLE FROM THE PEDAL

- Note: You must remove chain CONNECTOR (D) from SQUARE SHAFT (E) prior to removing the CABLE BRACKET (A).
1. Loosen CHAIN CONNECTOR (D) DRUM KEY SCREW, slide CHAIN CONNECTOR off SQUARE SHAFT (E).
 2. Loosen FOOTBOARD BRACKET (B) DRUM KEY SCREW and slide CABLE BRACKET (A) out of FOOTBOARD BRACKET (B).
 3. Loosen DRUM KEY SCREW (F) and loosen DRUM KEY SCREW (J)
 4. Remove the HEX CABLE HOLDER (G) and LONG CHAIN CONNECTOR (I) from the BEATER MECHANISM ASSEMBLY.
 5. Store all items in bag for transport.

SPRING TENSION ADJUSTMENTS

1. Loosen KNURLED NUT.
2. Pull HEX NUT out of cavity, turn to desired tension.
3. Tighten KNURLED NUT.

BEATER ANGLE ADJUSTMENTS

1. Loosen SPRING ROCKER DRUM KEY SCREW.
2. Place beater at desired angle.
3. Tighten KEY SCREW.

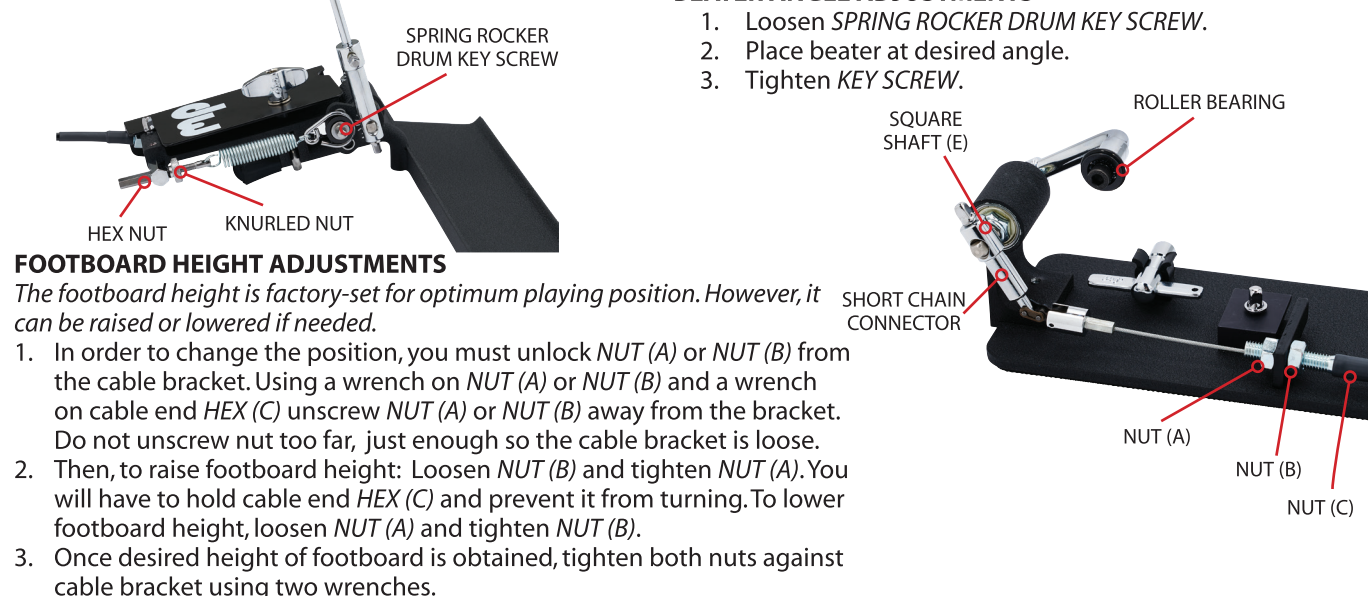

FOOTBOARD HEIGHT ADJUSTMENTS

The footboard height is factory-set for optimum playing position. However, it can be raised or lowered if needed.

1. In order to change the position, you must unlock NUT (A) or NUT (B) from the cable bracket. Using a wrench on NUT (A) or NUT (B) and a wrench on cable end HEX (C) unscrew NUT (A) or NUT (B) away from the bracket. Do not unscrew nut too far, just enough so the cable bracket is loose.
2. Then, to raise footboard height: Loosen NUT (B) and tighten NUT (A). You will have to hold cable end HEX (C) and prevent it from turning. To lower footboard height, loosen NUT (A) and tighten NUT (B).
3. Once desired height of footboard is obtained, tighten both nuts against cable bracket using two wrenches.

DW 5000 CAJON DIRECT LINK

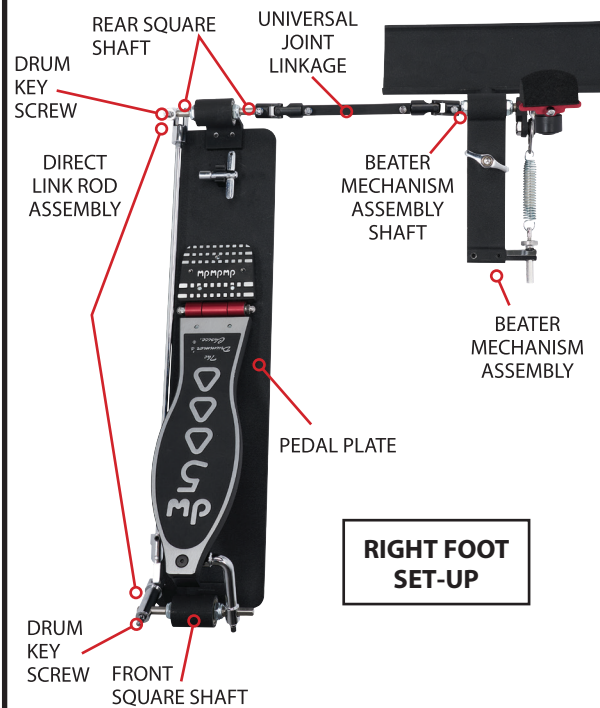

SETTING UP THE DIRECT LINK CAJON PEDAL

1. Take the included UNIVERSAL JOINT LINKAGE and attach one end onto the BEATER MECHANISM ASSEMBLY SHAFT. Tighten the DRUM KEY SCREW in line with the BEATER SHAFT. Position the opposite end onto the REAR SQUARE SHAFT of the PEDAL PLATE. You will have to rotate shaft to align the square in proper position (turning shaft will raise the roller bearing and push the footboard up).
2. Tighten all DRUM KEY SCREWS.

TEARING DOWN THE DIRECT LINK CAJON PEDAL FOR STORAGE

1. Loosen the UNIVERSAL JOINTS DRUM KEY SCREWS connecting them to the SQUARE SHAFTS.
2. Remove the UNIVERSAL LINKAGE from the pedal by sliding them off the shafts.
3. Place all items in bag for transport.

FOOTBOARD HEIGHT ADJUSTMENT

1. Remove the REAR DIRECT LINK LEVER ARM from the REAR SQUARE SHAFT by loosening drum key screw.
2. Use the included 2.5mm Allen wrench to loosen the set screw that keeps the REAR JOINT from rotating.
3. Turn the REAR DIRECT LINK LEVER ARM and REAR JOINT at least one full rotation in either direction until the desired footboard height is determined.
4. Turn the REAR DIRECT LINK LEVER ARM Clockwise to raise the footboard and Counter-Clockwise to lower the footboard.
5. Once the desired footboard height is set, put the REAR DIRECT LINK LEVER ARM back on the shaft and tighten all DRUM KEY SCREWS. Then tighten the 2.5mm HEX SCREW. Do not over tighten.
6. Do not adjust opposite end of rod.

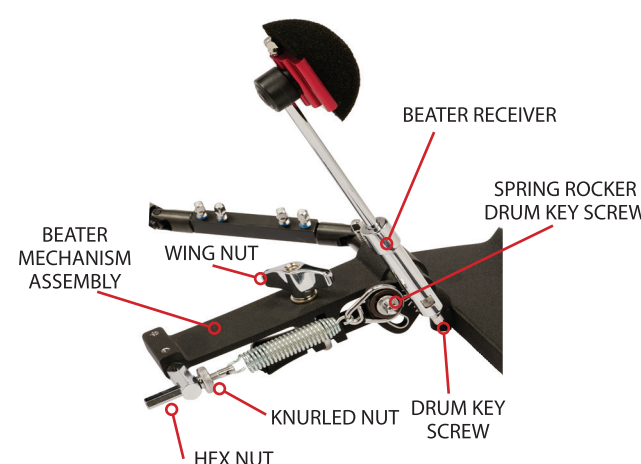
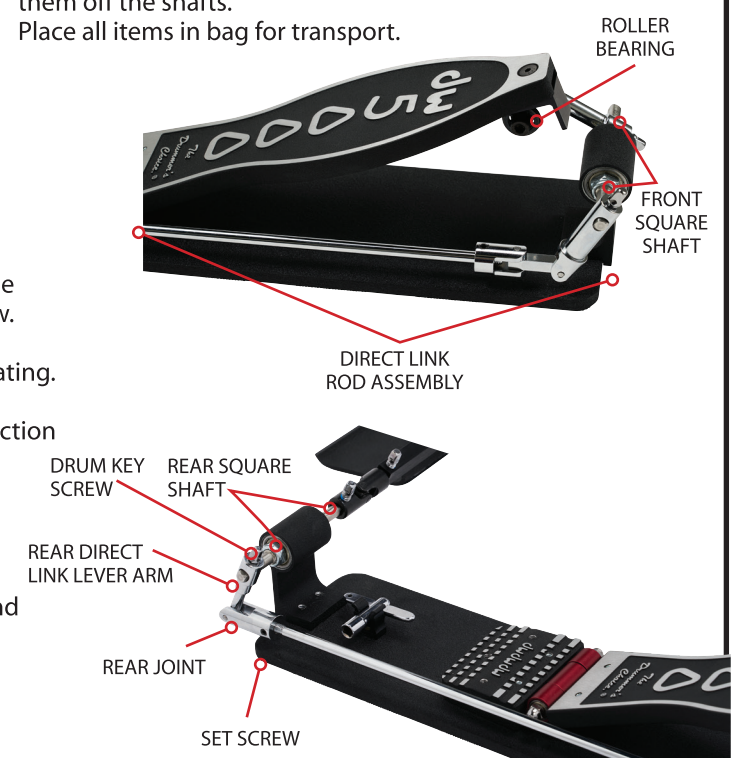

SPRING TENSION ADJUSTMENTS

1. Loosen KNURLED NUT.
2. Pull HEX NUT out of cavity, turn to desired tension.
3. Tighten KNURLED NUT.

BEATER ANGLE ADJUSTMENTS

1. Loosen SPRING ROCKER DRUM KEY SCREW.
2. Place beater at desired angle.
3. Tighten KEY SCREW.

CONVERTING TO LEFTY

1. Remove the DIRECT LINK ROD ASSEMBLY from the FRONT and REAR SQUARE SHAFTS by loosening the DRUM KEY SCREWS.
2. Move the DIRECT LINK ROD ASSEMBLY to the opposite side of the PEDAL PLATE. Tighten the DRUM KEY SCREWS.
3. Remove the BEATER RECEIVER from the BEATER MECHANISM ASSEMBLY by loosening the DRUM KEY SCREW.
4. Move the BEATER RECEIVER to the opposite square on the same shaft. Tighten the DRUM KEY SCREW.
5. Remove RUBBER BUMPERS from the arms of the CAJON PLATE.
6. Loosen the WING NUT and move the BEATER MECHANISM ASSEMBLY to the opposite arm of the PEDAL PLATE. Re-attach RUBBER BUMPERS.
7. Setup your Cajon as normal (see above: Setting Up the Direct Link Cajon Pedal).

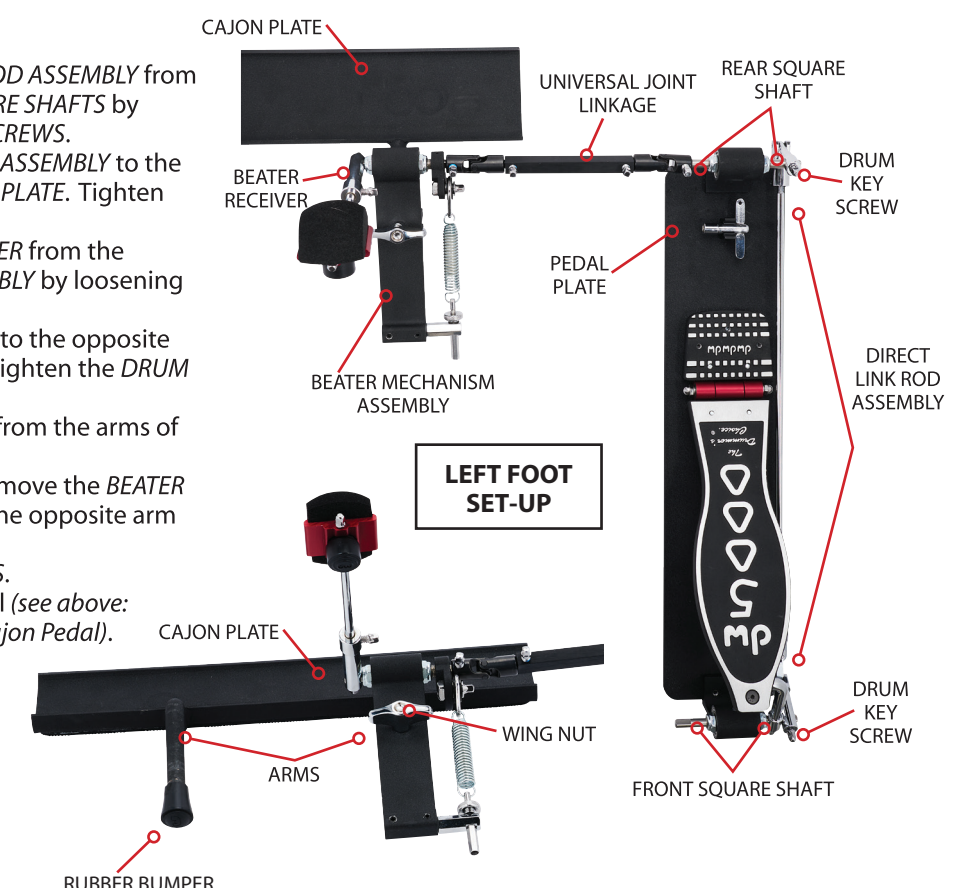

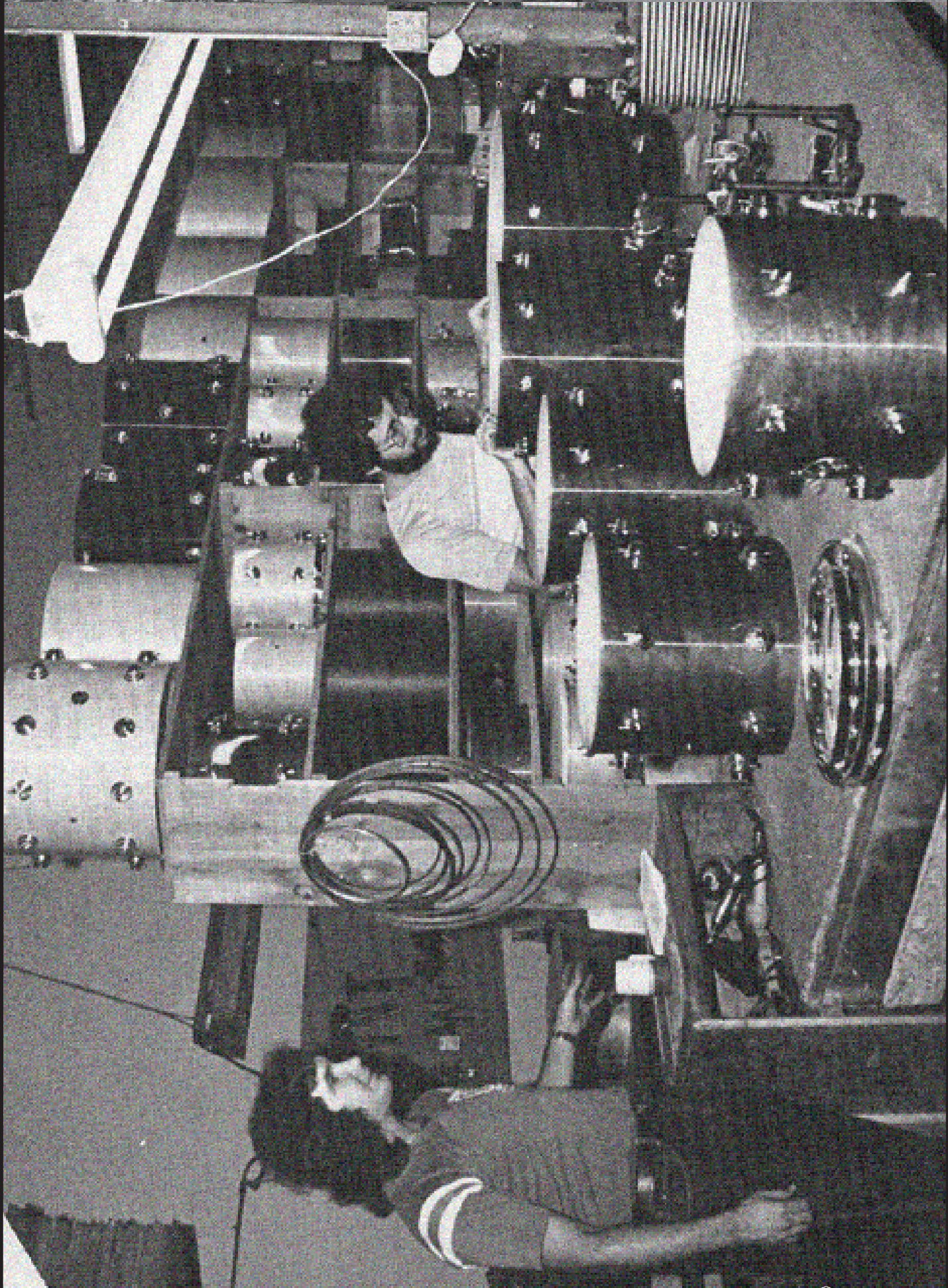

At Drum Workshop, The Drummer's Choice® is more than a slogan, it's a fact. After more than four decades of innovation and tireless dedication to improving the way drum products are made, DW drums, pedals and hardware are the standard by which all others are measured. To get here, it takes more than a working knowledge of the instrument or a few good ideas; it takes a true passion for designing and manufacturing the very best.

John Good

John Good