



General user guide

A guide for general product use and set up



TABLE OF CONTENT

PART I: OVERVIEW, INSTALLATION, AND GUIDELINES FOR SAFE USE

About Altura truss	3
Purpose and application	
Transport	
Installation & Removal	
Load charts	4
FA31 Loading Table	
FA33 Loading Table	5
FA33/H Loading Table	6
FA34 Loading Table	7
FA34/H Loading Table	8
Climate load	9
Compatibility with other brands	
Silver sticker markings	
Maintenance	10
Grounding Information	
Certificates	

PART 2: GENERAL USER INSTRUCTIONS

Operating Trusses	11
Operation - Suspension Rigging Rules	
Illustration	12
Regular Inspections	13
Disposal Criteria	
Regular Inspections	
Truss Damages	
Connectors and Connecting Elements	

Please read this manual carefully in order to ensure proper installation and operation of the truss systems.

Warning

This document provides general guidance on how to use the product. For particular applications or situations, it is recommended to contact the manufacturer to confirm the correct usage. The information presented here is not legally binding and serves only as a general reference. The manufacturer is not responsible for any damage or problems resulting from use outside these guidelines.



PART I: OVERVIEW, INSTALLATION, AND GUIDELINES FOR SAFE USE

About Altura truss

With Altura, your construction quite literally reaches new heights. This ambitious brand—whose name fittingly means “height” or “peak”, bridges the gap between affordability and uncompromising, professional quality. Altura truss is manufactured in Europe according to the strictest standards and carries essential TÜV certifications, allowing you to build above any audience with confidence.

The range is immediately impressively broad and modular. From the industry-standard FA34 square truss and sleek black versions for theaters, to specialized “High Load” systems and compact single tubes. Whether you’re rigging a DJ booth, exhibition stand, or a full festival stage, Altura provides a rock-solid backbone for your setup, complete with all conceivable accessories such as base plates and transport solutions. Quality you can rely on, at a price you wouldn’t expect.

Purpose and application

This guide is intended for qualified users. The Altura trusses and truss systems are designed exclusively to carry static loads. They may be suspended, installed, or relocated as needed. If dynamic forces are applied, additional structural calculations are required. For further information about dynamic loading, please contact the supplier. Load tables for static loads are included.

Transport

Ensure that Altura trusses are transported in accordance with local regulations. Make sure the load is properly secured to prevent any damage during transport.

Installation & Removal

Qualified and/or skilled personnel must install the Altura trusses in accordance with local regulations and the recommendations provided. Always ensure that the stability and load-bearing capacity comply with the requirements specified in the structural calculations or load tables. Inspect all components, including trusses and connectors, prior to installation, and perform regular system inspections. Any modifications, such as drilling new holes, will alter the load-bearing properties and must be reviewed by a structural engineer. Damaged parts, such as those showing cracks, deformation, or material loss, should be discarded and clearly marked. Use appropriate tools, such as rigging equipment, wrenches, and hammers made of copper, aluminum, or plastic, and assemble the trusses in the correct sequence. Confirm that all components are properly installed in accordance with the technical specifications.



Load charts

Load applications must follow the manufacturer’s instructions. Loads should be applied vertically and distributed evenly across the main tubes. Concentrating loads on one side can considerably reduce the truss’s load-bearing capacity. Horizontal loads should be avoided, as their combination with vertical forces may exceed the truss’s maximum capacity. If horizontal loads are required, ensure that the truss system is specifically designed to accommodate them and perform a separate structural calculation for combined loads. Load capacity tables are available for all Altura truss models. Please note that all load ratings are based solely on static loads.



FA31

SPECIFICATIONS FT31						
Tubes Alloy	50 x 2 mm (1.97 x 0.08 in)					
	EN AW-6082 T6					
LOADING TABLES						
	1 m	2 m	3 m	4 m		
UDL [kg/m]	430	109	49	27		
Deflection [mm]	9.4	37.4	84.2	149.7		
CPL [kg]	219	109	73	55		
Deflection [mm]	7.6	29.9	67.4	119.8		

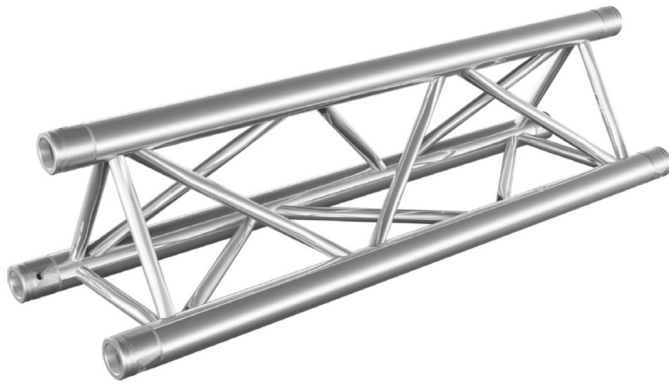

FA33

SPECIFICATIONS FT33						
Tubes Braces Alloy	50 x 2 mm (1.97 x 0.08 in)					
	20 x 2 mm (0.79 x 0.08 in)					
	EN AW-6082 T6					
LOADING TABLES						
	2 m	4 m	6 m	8 m	10 m	12 m
UDL [kg/m]	761	206	92	51	31	20
Deflection [mm]	2.6	11.5	26.8	48.8	75.2	105.6
CPL [kg]	761	412	277	206	154	117
Deflection [mm]	2.1	9.3	21.7	39.8	62	88.3

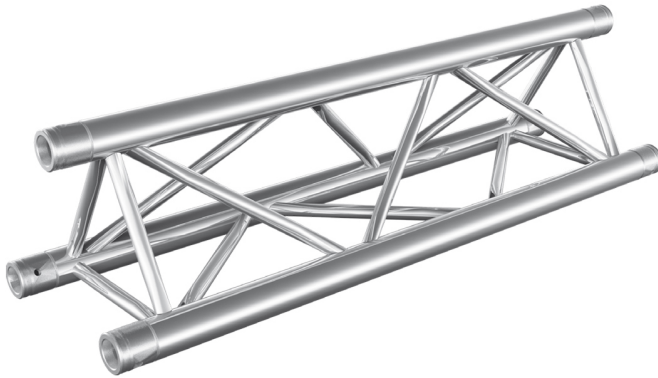

FA33/H

SPECIFICATIONS FA33

Tubes Braces Alloy	50 x 3 mm (1.97 x 0.12 in)
	20 x 2 mm (0.79 x 0.08 in)
	EN AW-6082 T6

LOADING TABLES

	2 m	4 m	6 m	8 m	10 m	12 m
UDL [kg/m]	1231	338	150	81	50	32
Deflection [mm]	2.9	12.8	29.4	51.7	80.6	112.7
CPL [kg]	1321	675	450	324	249	190
Deflection [mm]	2.5	10.3	23.7	42.1	66.1	93.5

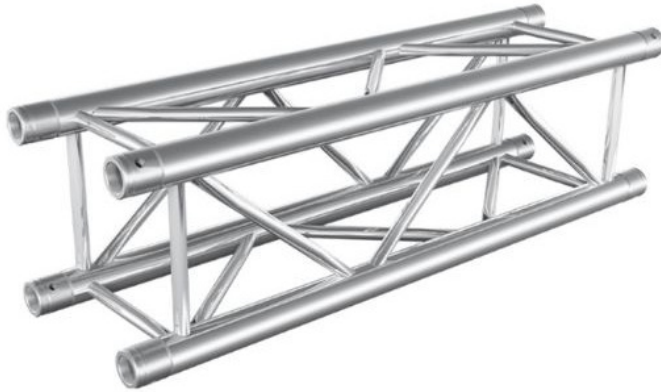

FA34

SPECIFICATIONS FA34

Tubes Braces Alloy

50 x 2 mm (1.97 x 0.08 in)

20 x 2 mm (0.79 x 0.08 in)

EN AW-6082 T6

LOADING TABLES

	2 m	4 m	6 m	8 m	10 m	12 m
UDL [kg/m]	1422	493	223	127	79	51
Deflection [mm]	2.4	13.7	31.8	58	90.5	126.4
CPL [kg]	1919	987	670	507	394	308
Deflection [mm]	2.6	11	25.6	46.9	73.6	103.6

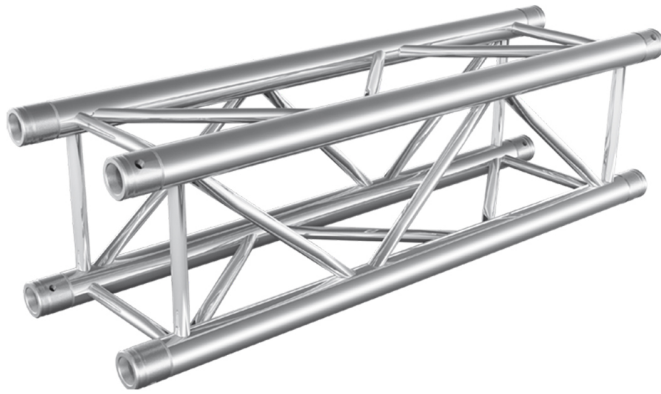

FA34/H

SPECIFICATIONS FA34

Tubes Braces Alloy

50 x 3 mm (1.97 x 0.12 in)

20 x 2 mm (0.79 x 0.08 in)

EN AW-6082 T6

LOADING TABLES

	2 m	4 m	6 m	8 m	10 m	12 m
UDL [kg/m]	1420	707	344	193	121	82
Deflection [mm]	1.7	13.3	33.2	59.8	93.9	134.8
CPL [kg]	2840	1544	1033	771	607	491
Deflection [mm]	2.7	11.7	26.7	48.3	76.2	110.1



Climate load

If the truss or truss structure is exposed to extreme temperatures, whether high or low, the load-bearing capacity may be affected. The structure should be carefully inspected for any damage caused by environmental conditions. For further guidance, please contact the supplier.

Compatibility with other brands

Altura trusses are fully compatible with a wide range of industry-standard truss systems, including Eurotruss, Global Truss, Intertruss, Hof, Microtruss, FORTEX, Milos U, Pro-Truss Pro, and Duratruss. This compatibility allows for smooth integration and maximum flexibility in different setups.

Silver sticker markings

All Altura trusses feature an identification label displaying the product type and quality control details.



Image 1.0: Silver sticker label



Maintenance

Do not apply lubricant to the truss connection components. Clean the trusses using water or alcohol-based cleaning agents and a soft cotton cloth. Make sure the trusses and all other components are adequately protected against water damage.

Grounding Information

Truss systems may conduct hazardous electrical voltages and must therefore be properly grounded. This applies to all conductive components on which electrical equipment may be installed. All conductive parts should be electrically bonded using clips, half couplers, screws, or similar connectors. After bonding, the structure must be connected to the protective conductor of the power supply. Use 16 mm² copper wire for distances up to 50 meters and 25 mm² copper wire for distances up to 100 meters. For tower systems, the columns must be connected to the main structural grid, as the mobile “Sleeve Block” component incorporates insulating silicone rollers or cylinders.

Certificates

The products are certified under several quality and safety standards. The CE marking applies to all Altura-welded components and confirms that these products comply with the applicable European directives (CE certificates are attached). The TÜV certification is valid for straight segments of the truss lines FA33, FA33/H, FA34, and FA34/H. Corners and circular segments are excluded, as they involve highly variable configurations and suspension setups. TÜV certification also does not apply to welded accessories. The GSI/SLV logo is exclusively valid for welded products and confirms that our welders are certified and regularly re-tested. These certifications demonstrate our commitment to quality, safety, and professional workmanship.

ALTURA



PART 2: GENERAL USER INSTRUCTIONS

Operating Trusses

If personnel are working beneath the trusses, the regulations specified in BGV C1, “Staging and Production Facilities for Scenic Presentations,” must be observed. In addition, any applicable local standards or regulations at the construction site should be reviewed and followed

Operation - Suspension Rigging Rules

There are three primary types of suspension (see SQP1 of VPLT standard):

1) Direct, straight suspension

The suspension points are secured directly to the truss using half couplers, profiles, or half couplers equipped with rigging eyes.

2) Tightened slings

Round slings are used in pairs to support each side of the truss before being connected to a shackle or hook. Please note that attaching slings tightly to the top or bottom tubes reduces their load capacity to approximately 80% of their rated capacity. When two identical slings are used, the total load capacity is limited to 1.6 times the rated capacity, depending on the sling angle.

3) Wrap sling

The sling is placed beneath the main strap, runs along both sides of the truss, and is then secured around the main straps, finishing with a hook or shackle. Depending on the angle, this configuration can increase the sling’s load capacity to between 1.4 and 2 times its rated capacity.

Suspension angles exceeding 60° are prohibited. Ensure that the suspension near the cross-brace can absorb compressive forces between the main straps.

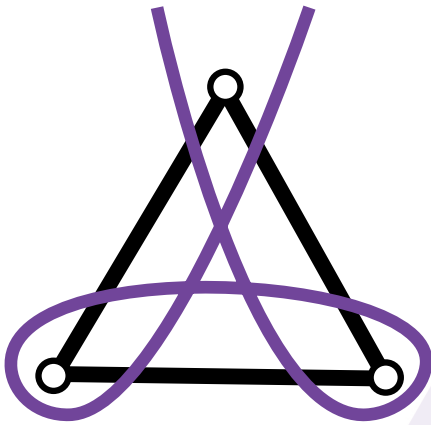

Triangular truss, apex up, 1 sling, inverted basket on bottom chords

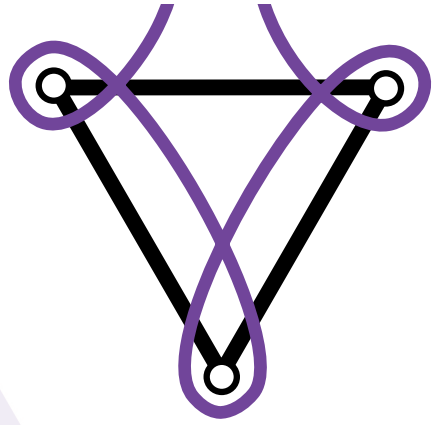

Triangular truss, apex down, 1 sling, basket on bottom chords and wraps on top chords

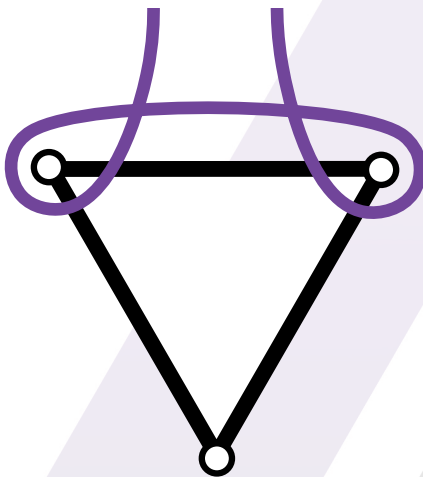

Triangular truss, apex down, 1 sling, inverted basket on top chords

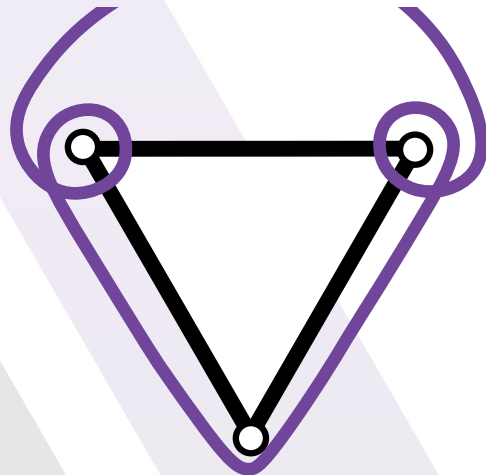

Triangular truss, apex down, 1 sling, basket with wraps on top chords

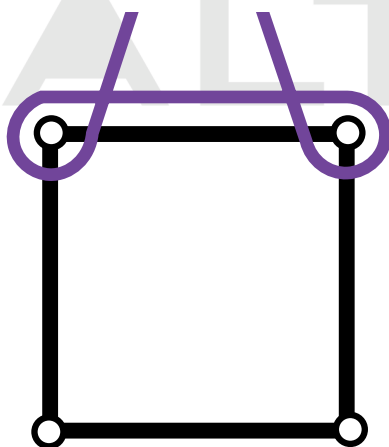

Rectangular truss, 1 sling, inverted basket on top chords

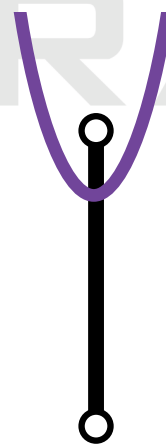

Two chord truss, 1 sling basket on top chords



Regular Inspections

Truss systems must be inspected based on their type of use and frequency of operation to identify any defects at an early stage. At a minimum, they should be examined once per year by a qualified professional, and an inspection report should be prepared.

Disposal Criteria

Discard the trusses if they exhibit any of the following types of damage that could compromise safe use. If you are uncertain about the extent of the damage, please consult the manufacturer for advice.

Truss Damages:

- Cross-section reduction due to wear (main pipes, connecting braces, diagonal braces)
- Weld thickness reduction due to wear
- Plastic deformation of profiles
- Holes in the profiles
- Missing pipes or diagonal braces
- Connection failure (truss no longer aligns with others)
- Broken welds
- Improper repairs
- Corrosion

Connectors and Connecting Elements:

- Wear causing reduction in cross-section of connectors
- Weld thickness reduction from wear
- Plastic deformation of connectors
- Enlarged holes
- Plastic deformation of connecting elements
- Signs of corrosion on connectors, pins, or clips
- Corrosion between bearing profiles and connectors
- Broken welds
- Improper repairs

Note:

All pins must be completely inserted after the components have been connected. The conical bolt with an M8 thread is well suited for frequent assembly and disassembly. Pre-assembled cone connectors help streamline the installation process and reduce the risk of losing connectors or fasteners. For circular, oval, or other non-linear structures, it is recommended to insert the safety pins first and secure them only after the components have been successfully assembled. For load data regarding individual TAF systems, please refer to the appropriate catalog.

If you have any additional questions, please contact your local distributor.