

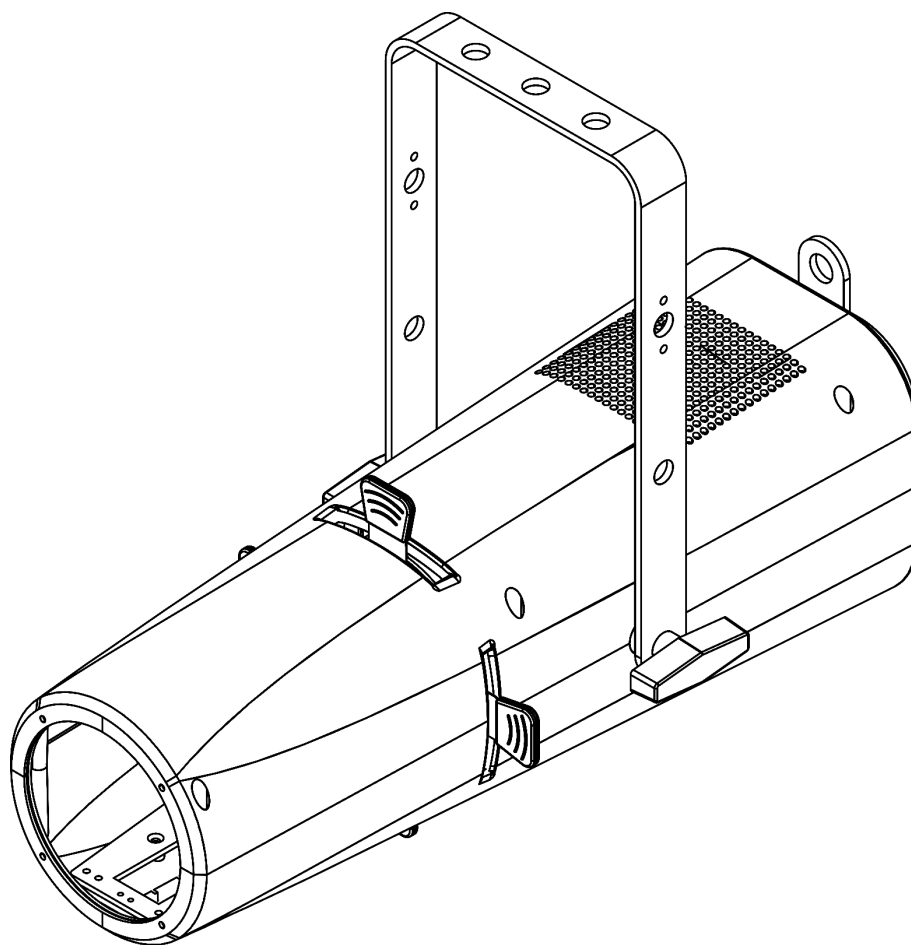

USER MANUAL



ENGLISH

Performer Profile Zoom 150 Q6 V2

Product code: 33059

Preface

Thank you for purchasing this Showtec product.

The purpose of this user manual is to provide instructions for the correct and safe use of this product.

Keep the user manual for future reference as it is an integral part of the product. The user manual shall be stored at an easily accessible location.

This user manual contains information concerning:

- Safety instructions
- Installation and operation of the device
- Intended and non-intended use of the device
- Maintenance procedures
- Troubleshooting
- Transport, storage and disposal of the device

Non-observance of the instructions in this user manual may result in serious injuries and damage of property.

©2025 Showtec. All rights reserved.

No part of this document may be copied, published or otherwise reproduced without the prior written consent of Highlite International.

Design and product specifications are subject to change without prior notice.

For the latest version of this document or other language versions, please visit our website www.highlite.com or contact us at service@highlite.com.

Highlite International and its authorized service providers are not liable for any injury, damage, direct or indirect loss, consequential or economic loss or any other loss arising from the use of, or inability to use or reliance on the information contained in this document.

Table of contents

1. Introduction	4
1.1. Before Using the Product	4
1.2. Intended Use	4
1.3. Product Lifespan	4
1.4. LEDs Lifespan	4
1.5. Text Conventions	4
1.6. Symbols and Signal Words.....	5
1.7. Symbols on the Information Label.....	5
2. Safety	6
2.1. Warnings and Safety Instructions.....	6
2.2. Requirements for the User.....	8
3. Description of the Device	9
3.1. Front View	9
3.2. Back View	10
3.3. Product Specifications	11
3.4. Dimensions.....	12
3.5. Optional Accessories	12
4. Installation	13
4.1. Safety Instructions for Installation.....	13
4.2. Personal Protective Equipment.....	13
4.3. Installation Site Requirements	13
4.4. Rigging	14
4.4.1. Angle Adjustment	15
4.5. Installation of Gobo Holder	16
4.6. Connecting to Power Supply	17
4.7. Power Linking of Multiple Devices	17
5. Setup	18
5.1. Warnings and Precautions	18
5.2. Stand-alone Setup.....	18
5.3. DMX Connection	18
5.3.1. DMX-512 Protocol	18
5.3.2. DMX Cables.....	19
5.3.3. Master/Slave Setup	19
5.3.4. DMX Linking	20
5.3.5. DMX Addressing.....	20
6. Operation	21
6.1. Safety Instructions for Operation	21
6.2. Control Modes	21
6.3. Control Panel	22
6.4. Start-up	22
6.5. Menu Overview	23
6.6. Main Menu Options.....	26
6.6.1. Static	26
6.6.2. DMX Address	26
6.6.3. Run Mode	26
6.6.4. Personality (DMX Channel Modes).....	27
6.6.5. Preset Color	27
6.6.6. Auto Programs	27
6.6.7. Edit.....	28
6.6.7.1. Upload	28
6.6.8. Settings.....	29
6.6.8.1. Reset.....	29
6.6.8.2. Dimmer.....	29

6.6.8.3.	DMX Error	30
6.6.8.4.	PWM Rate	30
6.6.8.5.	Performance	30
6.6.8.6.	Disp Key (Display Lock)	30
6.6.8.7.	Disp Time (Display Time)	30
6.6.8.8.	Color Calibration	31
6.6.8.9.	User Calibration.....	31
6.6.9.	Information	32
6.6.9.1.	Fixture Hours.....	32
6.6.9.2.	Version	32
6.6.9.3.	RDM	32
6.6.10.	CCT (Correlated Color Temperature Control)	33
6.6.11.	Preset Color	33
6.7.	DMX Channels	34
6.7.1.	3 Channels, 8 Channels, 13 Channels, 20 Channels	34
6.7.2.	7 Channels.....	37
6.7.3.	10 Channels.....	38
6.8.	RDM Information	41
6.8.1.	RDM Details	41
6.8.2.	Supported RDM PIDs (Parameter IDs)	42
7.	Troubleshooting	43
8.	Maintenance	44
8.1.	Safety Instructions for Maintenance	44
8.2.	Preventive Maintenance.....	44
8.2.1.	Basic Cleaning Instructions.....	44
8.3.	Corrective Maintenance.....	45
9.	Deinstallation, Transportation and Storage	45
9.1.	Instructions for Deinstallation.....	45
9.2.	Instructions for Transportation	45
9.3.	Storage	45
10.	Disposal	46
11.	Approval.....	46

1. Introduction

1.1. Before Using the Product



Important
Read and follow the instructions in this user manual before installing, operating or servicing this product.

The manufacturer will not accept liability for any resulting damages caused by the non-observance of this manual.

After unpacking, check the contents of the box. If any parts are missing or damaged, contact your Highlite International dealer.

Your shipment includes:

- Showtec Performer Profile Zoom 150 Q6
- Schuko to Power Pro True cable (1,5 m)
- User manual

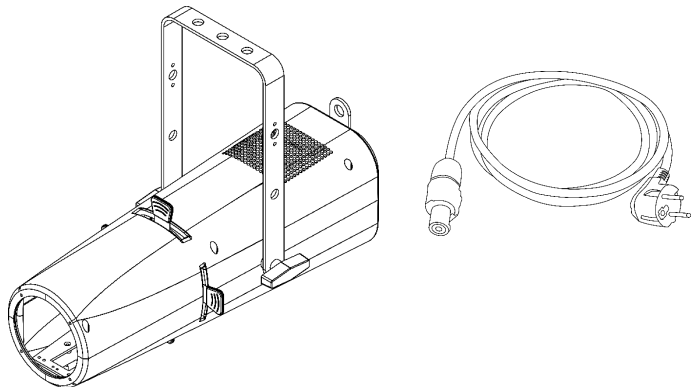

Fig. 01

1.2. Intended Use

This device is intended for professional use as a professional indoor LED profile. It is not suitable for households and for general lighting.

Any other use, not mentioned under intended use, is regarded as non-intended and incorrect use.

1.3. Product Lifespan

This device is not designed for permanent operation. Disconnect the device from the electrical power supply when the device is not in operation. This will reduce the wear and will improve the device's lifespan.

1.4. LEDs Lifespan

The light output of the LEDs gradually decreases over time (lumen depreciation). High operating temperatures contribute to this process. You can extend the lifespan of the LEDs by providing adequate ventilation and operating the LEDs at the lowest possible brightness.

1.5. Text Conventions









Throughout the user manual the following text conventions are used:

- Buttons: All buttons are in bold lettering, for example "Press the **UP/DOWN** buttons"
- References: References to chapters and parts of the device are in bold lettering, for example: "Refer to **2. Safety**", "turn the **adjustment handle (05)**"
- 0–255: Defines a range of values
- Notes: **Note:** (in bold lettering) is followed by useful information or tips

1.6. Symbols and Signal Words

Safety notes and warnings are indicated throughout the user manual by safety signs.





Always follow the instructions provided in this user manual.

	DANGER	Indicates an imminently hazardous situation which, if not avoided, will result in death or serious injury.
	WARNING	Indicates a potentially hazardous situation which, if not avoided, could result in death or serious injury.
	CAUTION	Indicates a potentially hazardous situation, which, if not avoided, may result in minor or moderate injury.
	Attention	Indicates important information for the correct operation and use of the product.
	Important	Read and observe the instructions in this document.
	Electrical hazard	
	Eye damage hazard	
		Provides important information about the disposal of this product.

1.7. Symbols on the Information Label

This product is provided with an information label. The information label is located on the mounting bracket of the device.

The information label contains the following symbols:

	This device shall not be treated as household waste.
	This device is designed for indoor use.
	This device falls under IEC protection class I.
	Read the user manual supplied with the device.

2. Safety



Important
Read and follow the instructions in this user manual before installing, operating or servicing this product.

The manufacturer will not accept liability for any resulting damages caused by the non-observance of this manual.

2.1. Warnings and Safety Instructions



DANGER
Danger for children

For adult use only. The device must be installed beyond the reach of children.

- Do not leave various parts of the packaging (plastic bags, polystyrene foam, nails, etc.) within children's reach. Packaging material is a potential source of danger for children.



DANGER
Electric shock caused by dangerous voltage inside

There are areas within the device where dangerous touch voltage may be present.

- Do not open the device or remove any covers.
- Do not operate the device if the covers or the housing are open. Before operation, check if the housing is firmly closed and all screws are tightly fastened.
- Disconnect the device from electrical power supply before service and maintenance, and when the device is not in use.



DANGER
Electric shock caused by short-circuit

This device falls under IEC protection class I.

- Make sure that the device is electrically connected to ground (earth). Connect the device only to a socket-outlet with ground (earth) connection.
- Do not cover the ground (earth) connection.
- Do not bypass the thermostatic switch or fuses.
- Do not let the power cable come into contact with other cables. Handle the power cable and all connections with the mains with caution.
- Do not modify, bend, mechanically strain, put pressure on, pull or heat up the power cable.
- Make sure that the power cable is not crimped or damaged. Examine the power cable periodically for any defects.
- Do not immerse the device in water or other liquids. Do not install the device in a location where flooding may occur.
- Do not use the device during thunderstorms. Disconnect the device from the electrical power supply immediately.



WARNING
Risk of epileptic shock

Strobe lighting can trigger seizures in photosensitive epilepsy. Sensitive persons should avoid looking at strobe lights.



CAUTION
Possible eye damage caused by high light intensity

Possibly hazardous optical radiation emitted from this device.

- Do not look at the operating light source. May be harmful to the eye.
- Do not look at the light source with optical instruments that may concentrate the light output.
- Make sure that persons are not looking directly into the light source when the device lights up suddenly. This can happen when the device is powered or when it receives DMX signal, or when certain menu items are selected.
- Disconnect power supply before servicing.
- Wear protective goggles if looking into light source during service or maintenance.



Attention
Power supply

- Before connecting the device to the power supply, make sure that the current, voltage and frequency match the input voltage, current and frequency specified on the information label on the device.
- Make sure that the cross-sectional area of the extension cords and power cables is sufficient for the required power consumption of the device.



Attention
General safety

- Do not connect the device to a dimmer pack.
- Do not switch the device on and off in short intervals. This decreases the device's life.
- Do not shake the device. Avoid brute force when installing or operating the device.
- Change the lens or the LEDs if they are visibly damaged to such an extent that their effectiveness is impaired, for example by cracks or deep scratches. Contact your Highlite International dealer for more information, as servicing can be performed only by instructed or skilled persons.
- If the device is dropped or struck, disconnect the device from the electrical power supply immediately.
- If the device is exposed to extreme temperature variations (e.g. after transportation), do not switch it on immediately. Let the device reach room temperature before switching it on, otherwise it may be damaged by the formed condensation.
- If the device fails to work properly, discontinue the use immediately.



Attention
For professional use only
This device shall be used only for the purposes it is designed for.

This device is designed to be used as a professional indoor LED profile. Any incorrect use may lead to hazardous situations and result in injuries and material damage.

- This device is not suitable for households and for general lighting.
- This device is not designed for permanent operation.
- This device does not contain user-serviceable parts. Unauthorized modifications to the device will render the warranty void. Such modifications may result in injuries and material damage.



Attention

Before each use, examine the device visually for any defects.

Make sure that:

- All screws used for installing the device or parts of the device are tightly fastened and are not corroded.
- The safety devices are not damaged.
- There are no deformations on housings, fixations and installation points.
- The lens is not cracked or damaged.
- The power cables are not damaged and do not show any material fatigue.



Attention

Do not expose the device to conditions that exceed the rated IP class conditions.

This device is IP20 rated. IP (Ingress Protection) 20 class provides protection against solid objects greater than 12 mm, such as fingers, and no protection against harmful ingress of water.

2.2. Requirements for the User

This product may be used by ordinary persons. Maintenance may be carried by ordinary persons. Installation and service shall be carried out only by instructed or skilled persons. Contact your Highlite International dealer for more information.

Instructed persons have been instructed and trained by a skilled person, or are supervised by a skilled person, for specific tasks and work activities associated with the installation, service and maintenance of this product, so that they can identify risks and take precautions to avoid them.

Skilled persons have training or experience, which enables them to recognize risks and to avoid hazards associated with the installation, service and maintenance of this product.

Ordinary persons are all persons other than instructed persons and skilled persons. Ordinary persons include not only users of the product but also any other persons that may have access to the device or who may be in the vicinity of the device.

3. Description of the Device

The Showtec Performer Profile Zoom 150 Q6 is an indoor 150-watt RGBACL LED profile with a high CRI of 95. It has a wide (manual) zoom range from 25 to 50 degrees and is dimmable from 0 to 100 % in 16-bit steps.

3.1. Front View

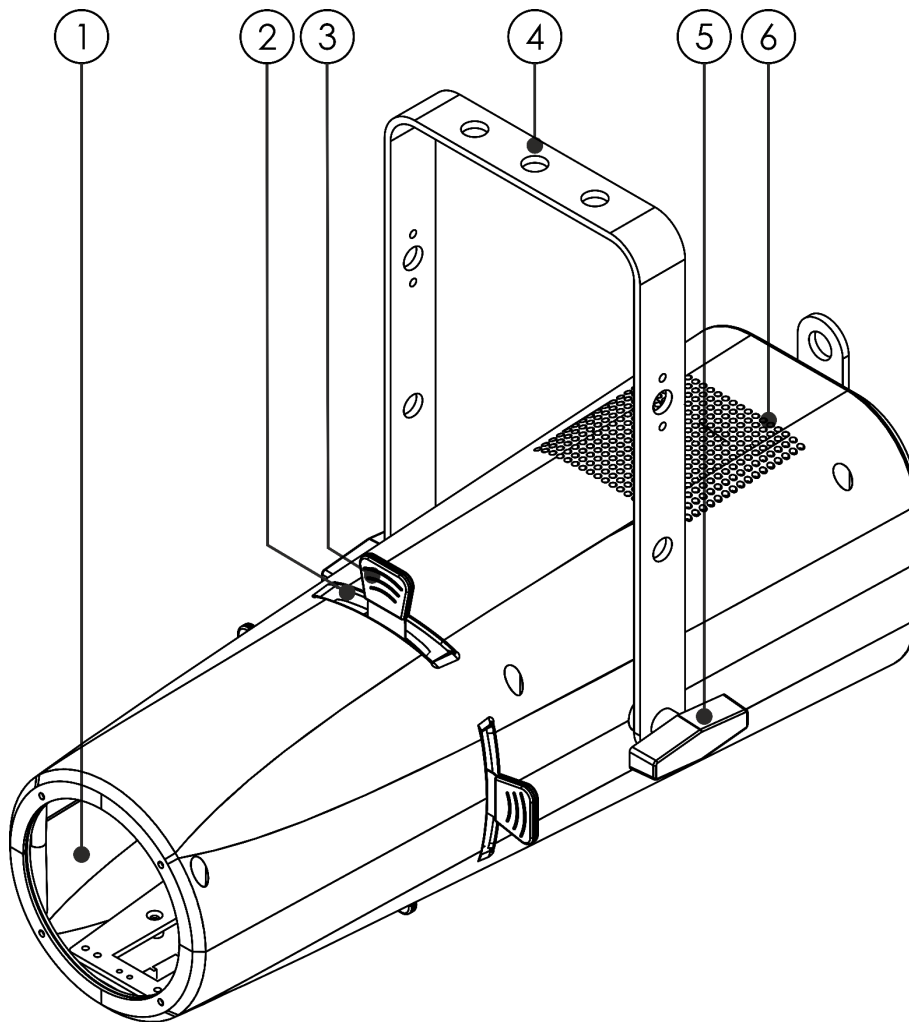

Fig. 02

- 01) Lens
- 02) Gobo holder slot
- 03) Shutter
- 04) Mounting bracket
- 05) Adjustment screw
- 06) Ventilation openings

3.2. Back View

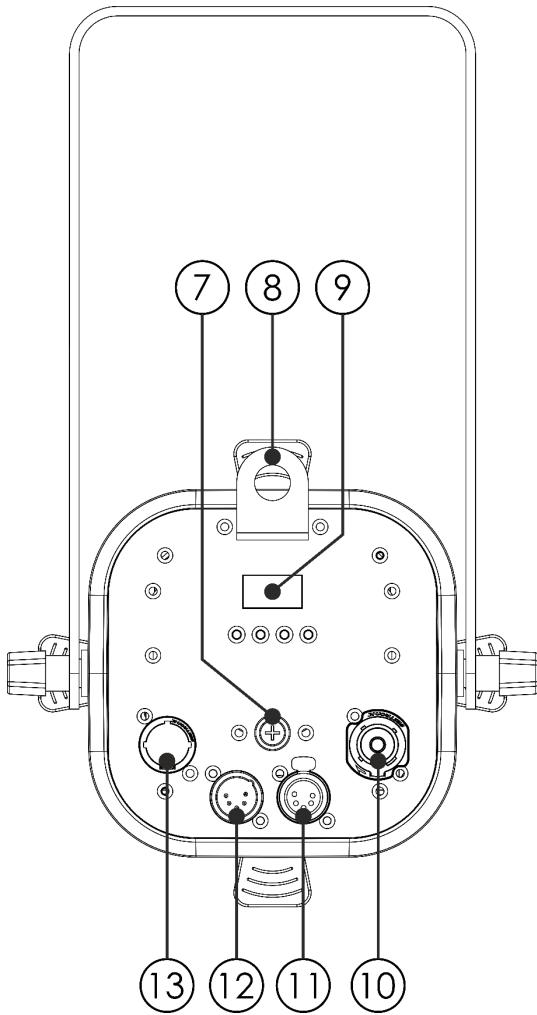

Fig. 03

- 07) Fuse 3,15 AL /250 V
- 08) Safety eye
- 09) OLED display and menu buttons
- 10) Power Pro True connector OUT
- 11) 5-pin DMX signal connector OUT
- 12) 5-pin DMX signal connector IN
- 13) Power Pro True connector IN

3.3. Product Specifications

Model:	Performer Profile Zoom 150 Q6	
Electrical:		
Input voltage:	100–240 V AC, 50/60 Hz	
Power consumption:	170 W	
Fuse:	3,15 AL/250 V	
Physical:		
Dimensions:	569 x 222 x 196 mm (L x W x H) (including bracket)	
Weight:	6,1 kg	
Optics:		
Light source:	150 W RGBACL LED	
Lumen total:	2624 lm	
Lux @ 2m:	1588 lx	
Lux @ 3m:	706 lx	
Lux @ 5m:	254 lx	
CRI:	95	
CCT minimum:	1800 K	
CCT maximum:	10000 K	
Refresh rate:	1200–25000 Hz	
Dimmer:	0–100 %	
Strobe:	0–25 Hz	
Zoom ratio:	1 : 2	
Zoom minimum:	25°	
Zoom maximum:	50°	
Operation and control:		
Control:	Manual, Auto, Built-in programs, Master/Slave, DMX-512, RDM	
DMX channels:	3, 7, 8, 10, 13, 20 channels	
Control panel:	OLED display and menu buttons	
Display size:	1,3 inch	
Connections:		
Power connections:	Power Pro True connectors IN/OUT	
Data connections:	5-pin DMX connectors IN/OUT	
Signal pinouts:	Pin 1 (ground), pin 2 (-), pin 3 (+), pin 4 (N/C), pin 5 (N/C)	
Construction:		
Housing:	ABS / aluminum / steel	
Color:	Black	
IP rating:	IP20	
Cooling:	Convection / axial fan	
Thermal:		
Minimum operating temperature:	0 °C	
Maximum ambient temperature t_a :	45 °C	
Maximum housing temperature t_c :	70 °C	
Minimum distance:		
Minimum distance from flammable surfaces:	1 m	
Minimum distance to lighted object:	0,5 m	

3.4. Dimensions

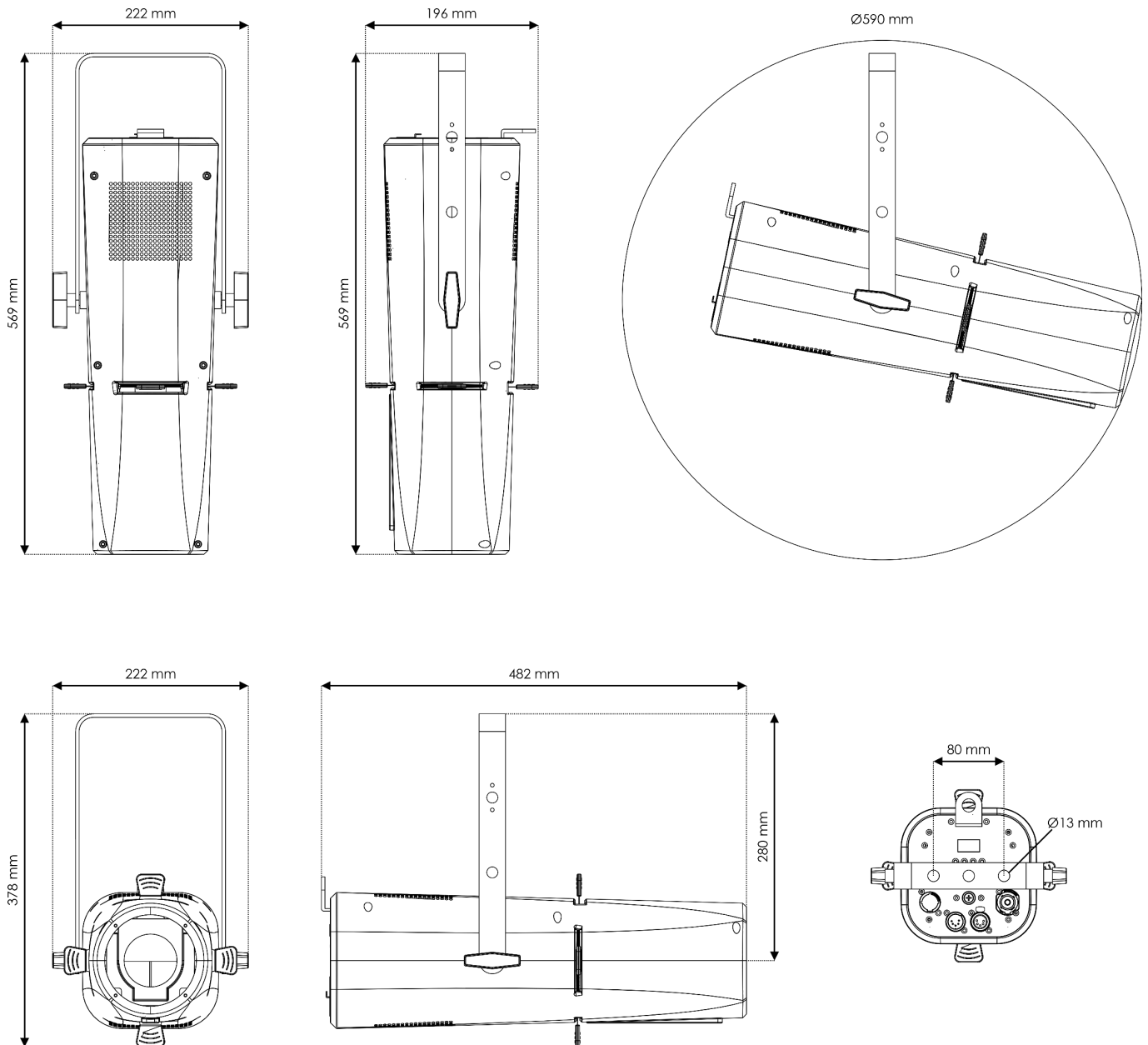

Fig. 04

3.5. Optional Accessories

- Product code: [33058](#) (Gobo Holder for Performer Profile 150 Q6)
- Product code: [33057](#) (Filter frame with holder for Performer Profile Zoom 150)

4. Installation

4.1. Safety Instructions for Installation



WARNING

Incorrect installation can cause serious injuries and damage of property.

If trussing systems are used, installation must be carried out only by instructed or skilled persons.

Follow all applicable European, national and local safety regulations concerning rigging and trussing.

4.2. Personal Protective Equipment

During installation and rigging wear personal protective equipment in compliance with the national and site-specific regulations.

4.3. Installation Site Requirements

- The device can be used outdoors.
- The device can be mounted to a truss or other rigging structure.
- The minimum distance between the light output and the illuminated surface must be bigger than 0,5 m.
- The maximum ambient temperature $t_a = 45\text{ °C}$ must never be exceeded.
- The relative humidity must not exceed 50 % with an ambient temperature of 45 °C.

4.4. Rigging

The device can be positioned on a flat surface or mounted to a truss or other rigging structure. Make sure that all loads are within the pre-determined limits of the supporting structure.



CAUTION

Restrict the access under the work area during rigging and/or derigging.

To mount the device, follow the steps below:

- 01) Use a clamp to attach the device to the supporting structure, as shown in Fig. 05. Make sure that the device cannot move freely. The use of a quick lock bracket is optional.
- 02) Secure the device with a secondary suspension, for example a safety cable. Make sure that the secondary suspension can hold 10 times the weight of the device. If possible, the secondary suspension should be attached to a supporting structure independent of the primary suspension. Put the safety cable through the **safety eye (08)**, as shown in Fig. 05.

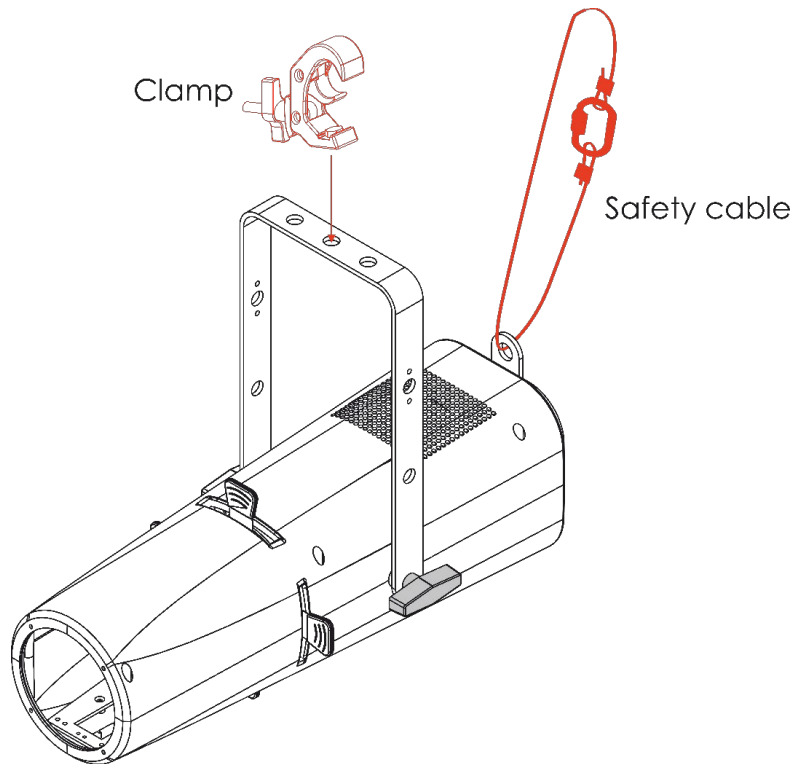

Fig. 05

4.4.1. Angle Adjustment

You can adjust the angle of the device with the 2 **adjustment screws (05)**.

- 01) Turn the **adjustment screws (05)** counterclockwise to release them.
- 02) Tilt the device at the desired angle (see Fig. 06).
- 03) Turn the **adjustment screws (05)** clockwise to tighten them. Make sure that the device cannot move freely after the **adjustment screws (05)** are tightened.

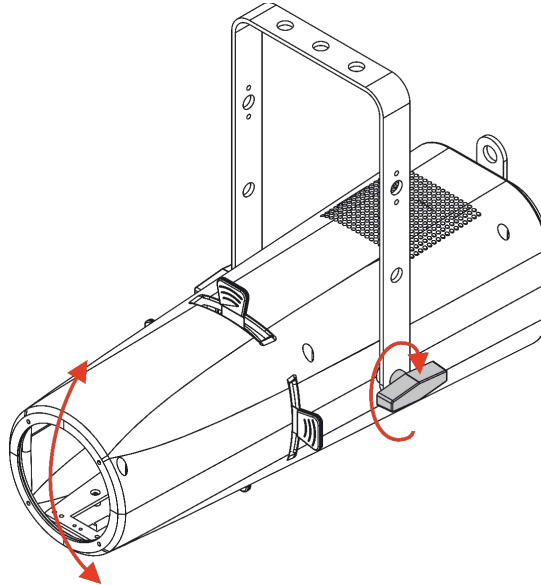

Fig. 06

4.5. Installation of Gobo Holder

To add the optional gobo holder to the device, following the steps below:

- 01) Insert a gobo into the gobo holder. Make sure that the front of the gobo is facing the front side of the gobo holder.

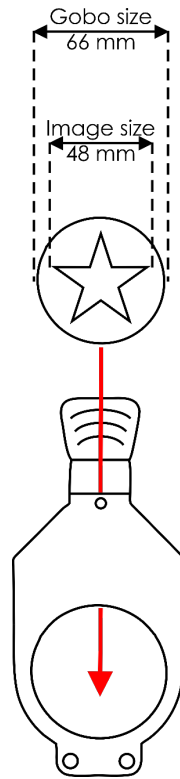

Fig. 07

- 02) Insert the gobo holder into the gobo holder slot (02).

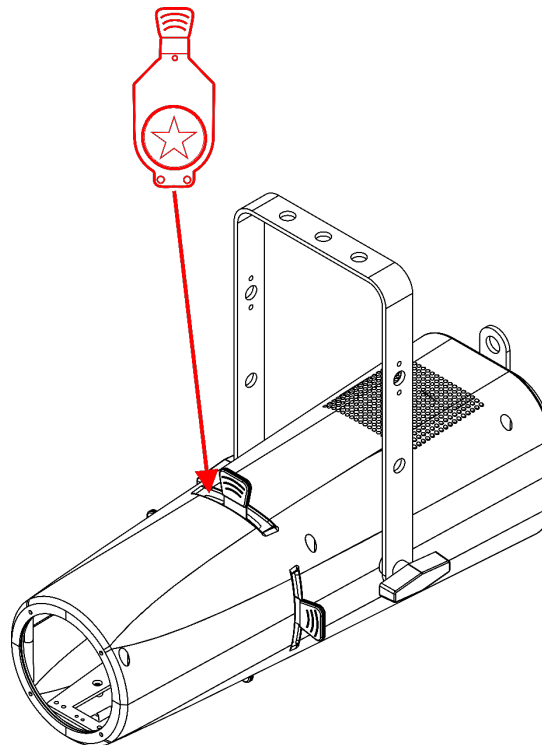

Fig. 08

4.6. Connecting to Power Supply



DANGER
Electric shock caused by short-circuit

The device accepts AC mains power at 100–240 V and 50/60 Hz. Do not supply power at any other voltage or frequency to the device.

This device falls under IEC protection class I. Make sure that the device is always electrically connected to the ground (earth).

Before connecting the device to the socket-outlet:

- Make sure that the power supply matches the input voltage specified on the information label on the device.
- Make sure that the socket-outlet has ground (earth) connection.

Connect the device to the socket-outlet with the power plug. Do not connect the device to a dimmer circuit, as this may damage the device.

4.7. Power Linking of Multiple Devices

This device supports power linking. Power can be relayed to another device via the power OUT connector. Note that the input and the output connectors have different designs: one type cannot be connected to the other.

Power linking of multiple devices must be carried out only by instructed or skilled persons.



WARNING
Incorrect power linking may lead to overload of the electrical circuit and result in serious injuries and damage of property.

To prevent overload of the electrical circuit, when power linking multiple devices:

- Use cables with sufficient current-carrying capacity. The power cable supplied with the device is not suitable for power linking of multiple devices.
- Make sure that the total current draw of the device and all connected devices does not exceed the rated capacity of the power cables and the circuit breaker.
- Do not link more devices on one power link than the maximum recommended number.

Maximum recommended number of devices:

- at 100–120 V: 4 devices
- at 200–240 V: 8 devices

5. Setup

5.1. Warnings and Precautions



Attention

Connect all data cables before supplying power.

Disconnect power supply before connecting or disconnecting data cables.

5.2. Stand-alone Setup

When the Performer Profile Zoom 150 Q6 is not connected to a controller or to other devices, it functions as a stand-alone device.

For more information about the control modes, refer to **6.2. Control Modes** on page 20.

5.3. DMX Connection

5.3.1. DMX-512 Protocol

You need a DMX serial data link to run light shows of one or more devices using a DMX-512 controller or to run synchronized shows of two or more devices set in a master/slave control mode.

The Performer Profile Zoom 150 Q6 has 5-pin DMX signal IN and OUT connectors.

The pin assignment is as follows: pin 1 (ground), pin 2 (-), pin 3 (+), pin 4 (N/C), pin 5 (N/C).

Devices on a serial data link must be daisy-chained in a single line. The number of devices that you can control on one data link is limited by the combined number of the DMX channels of the connected devices and the 512 channels available in one DMX universe.

To comply with the TIA-485 standard, no more than 32 devices should be connected on one data link. In order to connect more than 32 devices on one data link, you must use a DMX optically isolated splitter/booster, otherwise this may result in deterioration of the DMX signal.

Note:

- Maximum recommended DMX data link distance: 300 m
- Maximum recommended number of devices on a DMX data link: 32 devices

5.3.2. DMX Cables

Shielded twisted-pair cables with 3-pin XLR connectors must be used for reliable DMX connection. You can purchase DMX cables directly from your Highlite International dealer or make your own cables.

If you use XLR audio cables for DMX data transmission, this may lead to signal degradation and unreliable operation of the DMX network.

When you make your own DMX cables, make sure that you connect the pins and wires correctly as shown in Fig. 09.

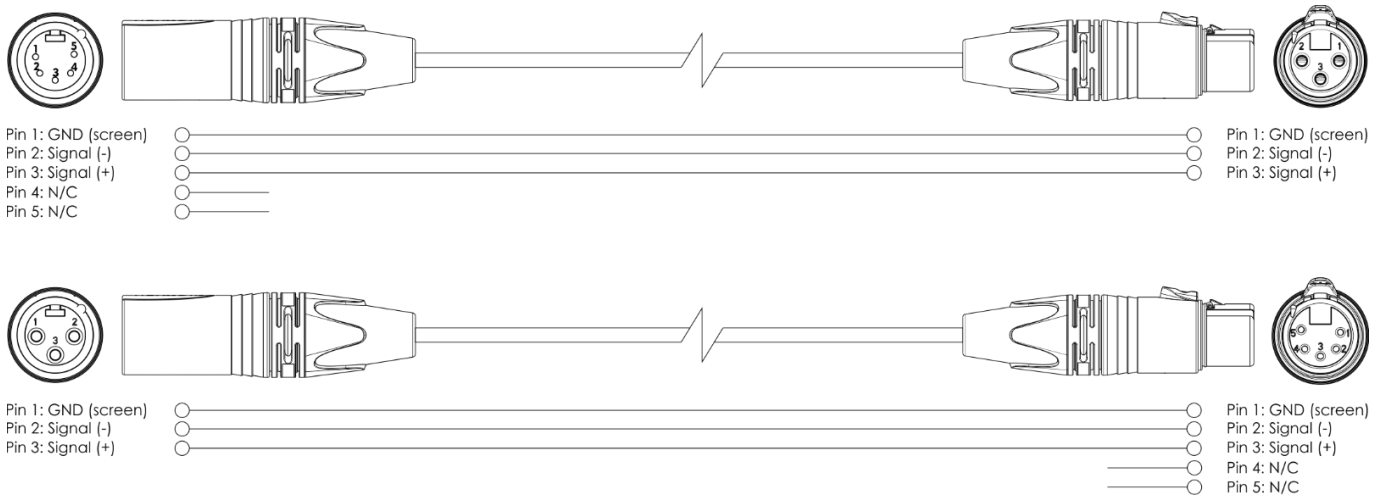

Fig. 09

5.3.3. Master/Slave Setup

The Performer Profile Zoom 150 Q6 supports master/slave control mode. To connect multiple devices in a master/slave setup, follow the steps below:

- 01) Connect the first device's DMX OUT connector to the second device's DMX IN connector.
- 02) Repeat step 1 to connect all devices as shown in Fig. 10.
- 03) Connect a DMX terminator (120 Ω resistor) to the DMX OUT connector of the last device in the setup.
- 04) Set the first device on the data link as a master device. See **6.6.3. Run Mode** on page 25 for more information.
- 05) Set the remaining devices to slave mode. See **6.6.3. Run Mode** on page 25 for more information.

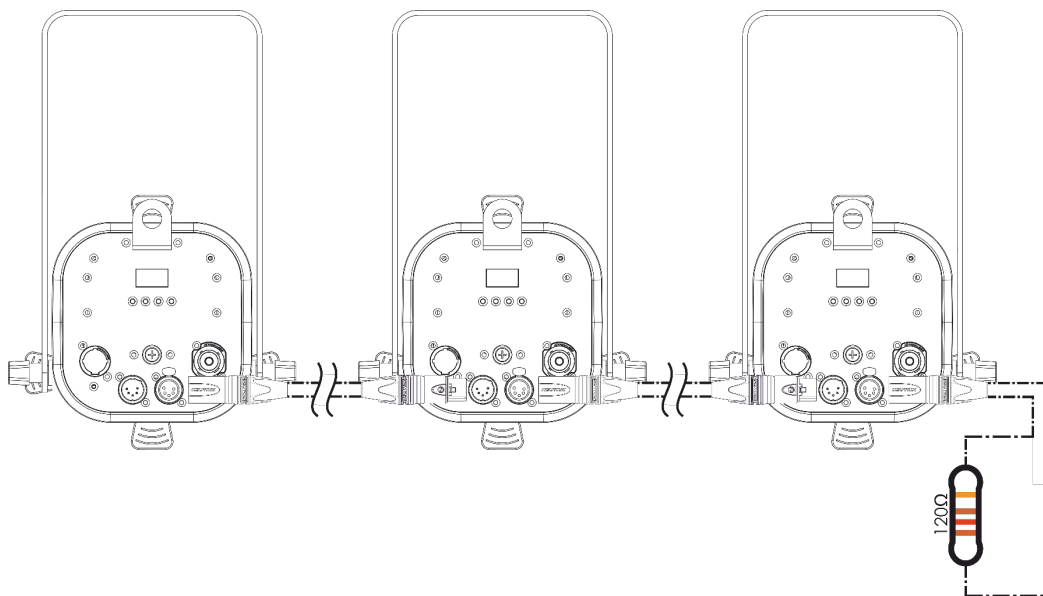

Fig. 10

5.3.4. DMX Linking

To connect multiple devices on one DMX data link, follow the steps below:

- 01) Use a 5-pin DMX cable to connect the DMX OUT connector of the lighting controller to the DMX IN connector of the first device.
- 02) Connect the first device's DMX OUT connector to the second device's DMX IN connector with a 5-pin DMX cable.
- 03) Repeat step 2 to connect all devices in a daisy-chain as shown in Fig. 11.
- 04) Connect a DMX terminator (120 Ω resistor) to the DMX OUT connector of the last device on the data link.

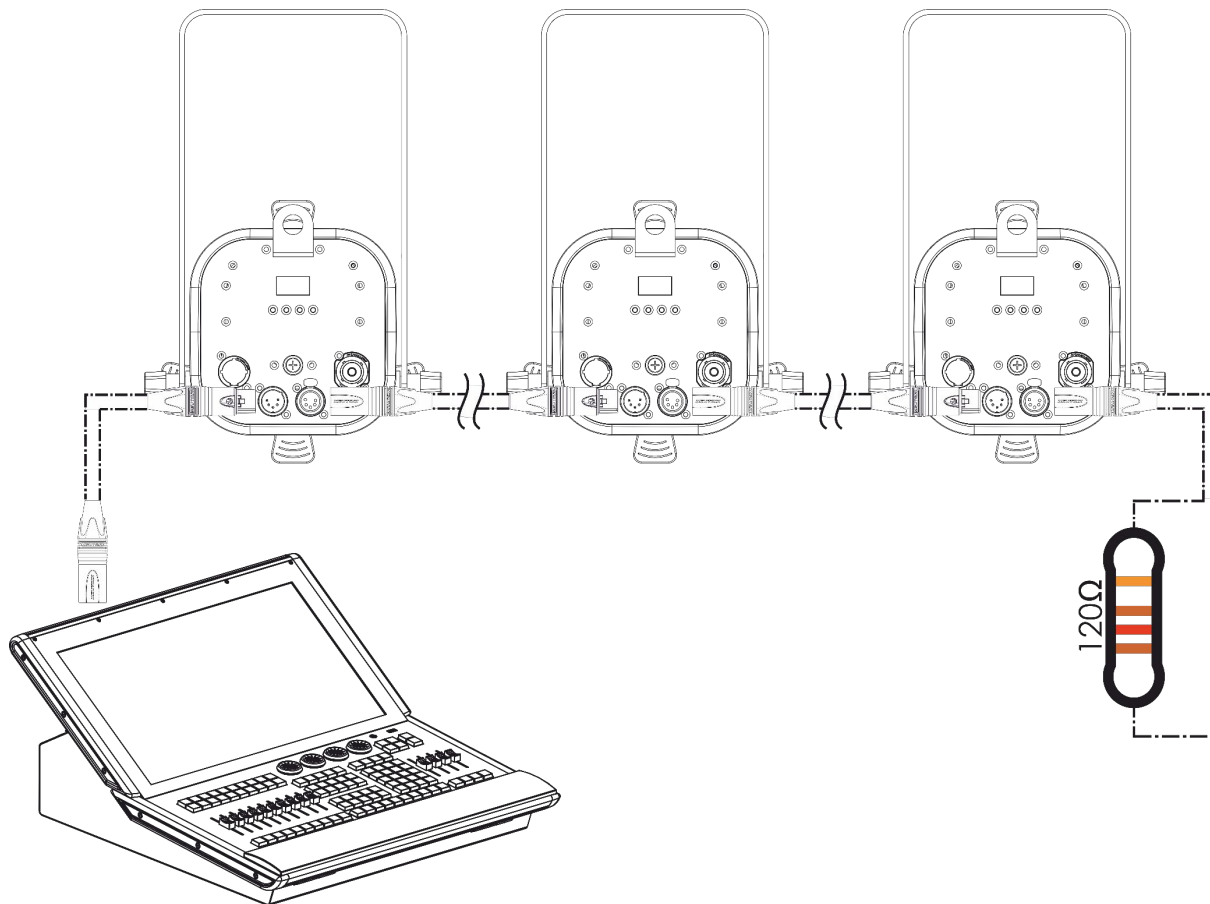

Fig. 11

5.3.5. DMX Addressing

In a setup with multiple devices, make sure that you set the DMX starting address of each device correctly. The Performer Profile Zoom 150 Q6 has 6 personalities: 3, 7, 8, 10, 13 or 20 channels.

If you want to connect multiple devices on one data link and use them in 20-channel mode, for example, follow the steps below:

- 01) Set the starting address of the 1st device on the data link to 1 (001).
- 02) Set the starting address of the 2nd device on the data link to 21 (021), as $1 + 20 = 21$.
- 03) Set the starting address of the 3rd device on the data link to 41 (041), as $21 + 20 = 41$.
- 04) Continue assigning the starting addresses of the remaining devices by adding each time 20 to the previous number.

Make sure that you do not have any overlapping channels in order to control the Performer Profile Zoom 150 Q6 correctly. If two or more devices are addressed similarly, they will work similarly.

6. Operation

6.1. Safety Instructions for Operation



Attention

This device must be used only for the purposes it is designed for.

This device is intended for professional use as a professional indoor LED profile. It is not suitable for households and for general lighting.

Any other use, not mentioned under intended use, is regarded as non-intended and incorrect use.



Attention

Power supply

Before connecting the device to the power supply, make sure that the current, voltage and frequency match the input voltage, current and frequency specified on the information label on the device.

6.2. Control Modes

The Performer Profile Zoom 150 Q6 can be operated with a DMX controller, or without a DMX controller as a stand-alone device or in a master/slave setup.

The Performer Profile Zoom 150 Q6 supports the following control modes:

- Stand-alone: Manual, Auto programs, customizable Built-in programs
- Master/Slave: Manual, Auto programs, customizable Built-in programs
- DMX-512, RDM 3, 7, 8, 10, 13, 20 channels

For more information about how to connect the devices, refer to **5. Setup** on pages 17–19.

To operate the device manually as a stand-alone device or in a master/slave setup:

- Adjust the colors in Static menu. See **6.6.1. Static** on page 25 for more information.

To run the built-in programs without a DMX controller:

- 01) Select one of the 10 built-in programs in Program menu. See **6.6.6. Auto Programs** on page 26 for more information. Adjust the program speed and strobe frequency.
- 02) Run all built-in programs in a sequence in Auto menu. See **6.6.6. Auto Programs** on page 26 for more information.

To run the preset colors without a DMX controller:

Select one of the 48 preset colors in Program menu. See **6.6.11. Preset Color** on page 32 for more information.

To operate the device with a DMX controller:

- 01) Set the DMX starting address of the device in Address menu. See **5.3.5. DMX Addressing** on page 19 and **6.6.2. DMX Address** on page 25.
- 02) Select the DMX channel mode. See **6.6.4. Personality** on page 26 for more information. See **6.7. DMX Channels** on pages 33–39 for complete overview of all DMX channels.

6.3. Control Panel

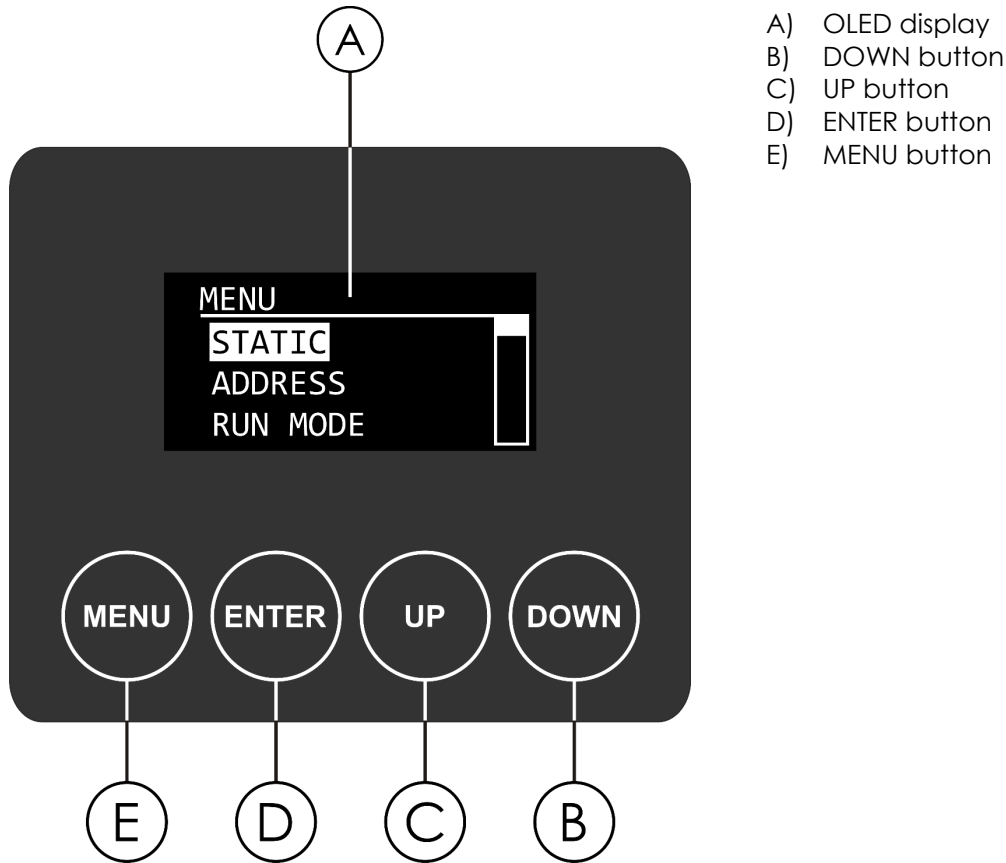

Fig. 12

- Use the **MENU** button to exit the current submenu and to return to the Main Menu.
- Use the **UP/DOWN** buttons to navigate through the menus or to increase/decrease numeric values.
- Use the **ENTER** button to open the desired menu, to confirm your choice or to set the currently selected value.

6.4. Start-up

Upon start-up the display will briefly show the Showtec logo.

Note:

If no button is pressed after 30 seconds of inactivity, the display will turn off.

To light up the display, you have to press the MENU, UP, DOWN or ENTER button. Once you have pressed the button, you will need to insert the password (press UP, DOWN, UP, DOWN, ENTER). See **6.6.8.6. Display Key** on page 29 for more information.

6.5. Menu Overview

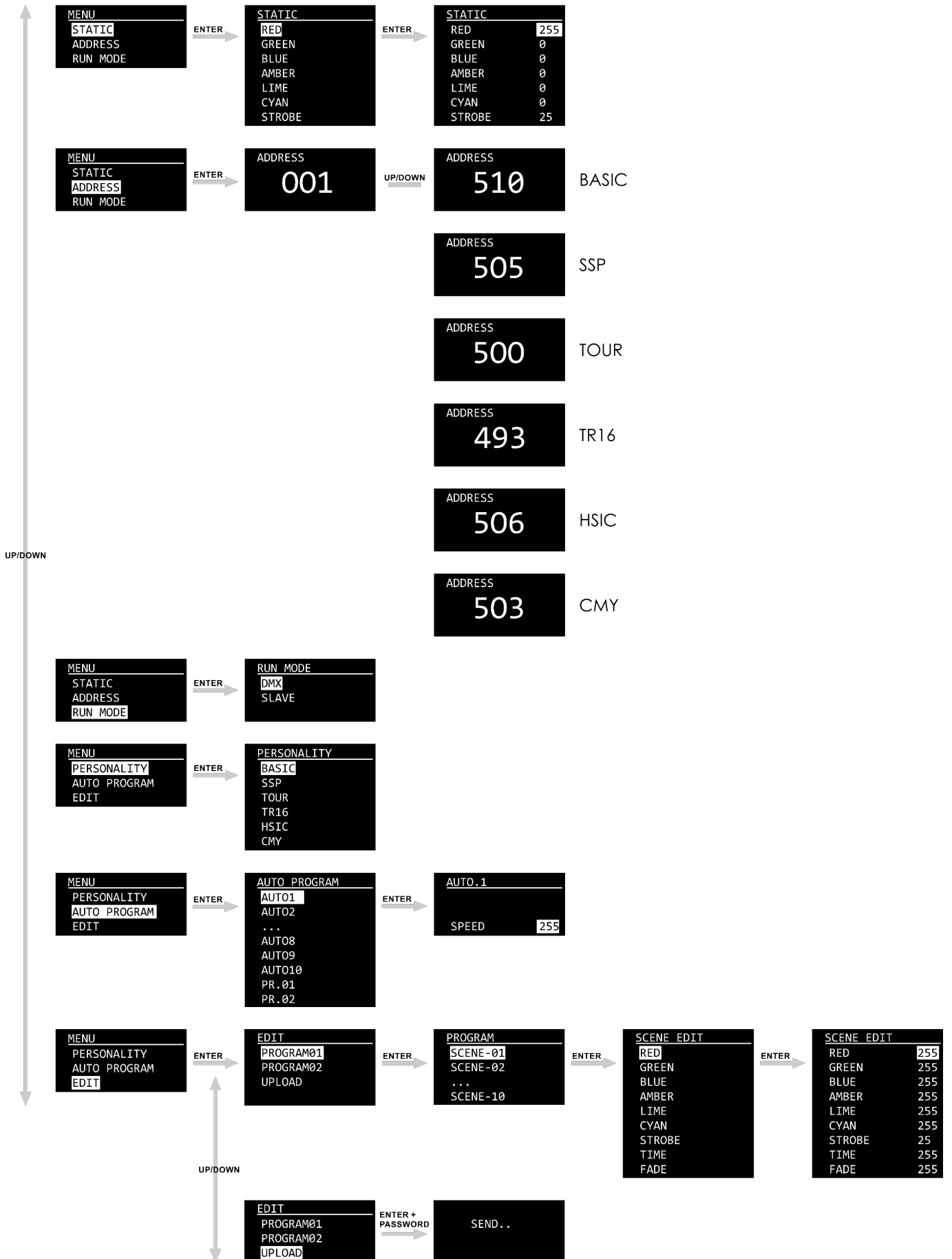

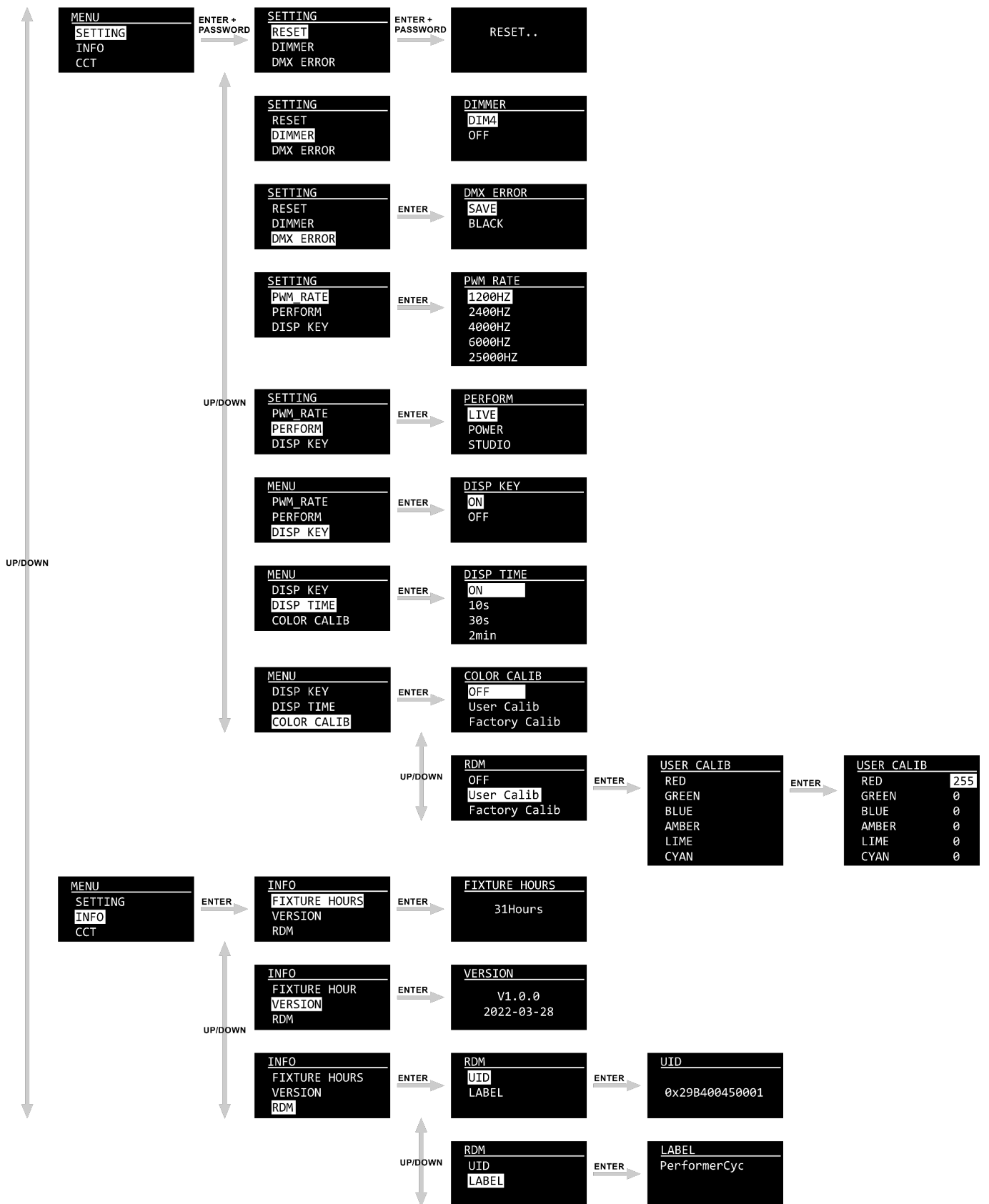

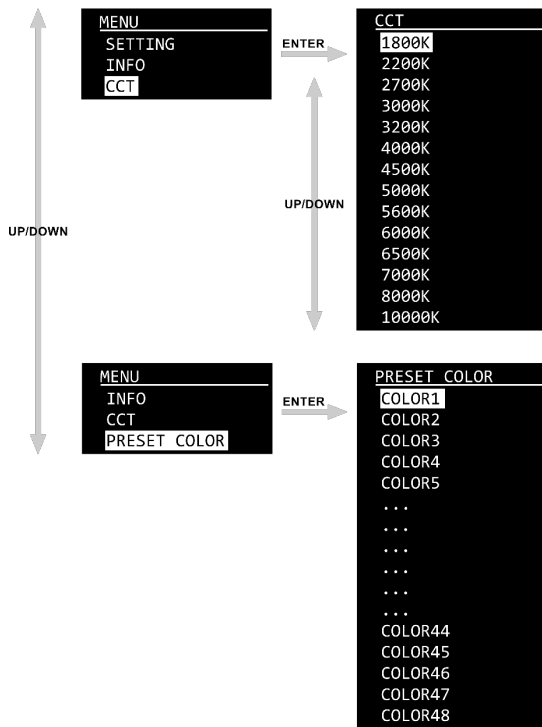

6.6. Main Menu Options

The main menu has the following options:



- 01) Press the **UP/DOWN** buttons to navigate through the main menu.
- 02) Press the **ENTER** button to open the submenus.

Note: Some of the submenus require a password. The default password is pressing the **UP/DOWN** buttons in the following order: **UP, DOWN, UP, DOWN, ENTER**. Deactivating the display lock does not affect the submenu items which by default require a password.

6.6.1. Static

In this menu, you can set the static colors to create an infinite range of colors.

- 01) Press the **UP/DOWN** buttons to scroll through the static colors (RED, GREEN, BLUE, AMBER, LIME, CYAN) and STROBE.
- 02) Press the **ENTER** button to open the settings submenu.
- 03) Press the **UP/DOWN** buttons to increase/decrease the values.
 - Color intensity (RED, GREEN, BLUE, AMBER, LIME, CYAN): the adjustment range is between 0–255, from low to high intensity
 - STROBE frequency: the adjustment range is between 0–25, from OFF to high frequency
- 04) Press the **ENTER** button to set the value and to move to the next setting.

6.6.2. DMX Address

In this menu you can set the device's DMX starting address.

- 01) Press the **UP/DOWN** buttons to set the desired DMX address. The adjustment range is between 001 and 493/500/503/505/506/510, depending on the currently selected DMX channel mode.
- 02) Press the **ENTER** button to save the changes.

6.6.3. Run Mode

In this menu you can set the control mode of the device.

- 01) Press the **UP/DOWN** buttons to toggle between the following 2 options:
 - DMX: the device will operate in DMX Mode.
 - SLAVE: the device will operate as a slave in Master/Slave Mode. It means that it will react the same as the master device.
- 02) Press the **ENTER** button to confirm your choice.

6.6.4. Personality (DMX Channel Modes)

In this menu you can set the DMX channel mode (personality).

01) Press the **UP/DOWN** buttons to select the desired DMX channel mode. There are 6 options available:

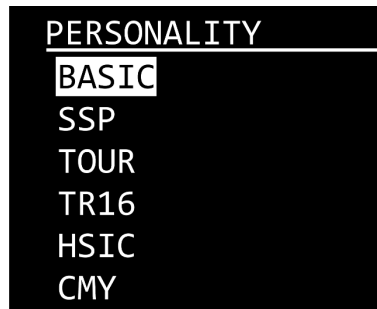

BASIC:	3 channels	TR16:	20 channels
SSP:	8 channels	HSIC:	7 channels
TOUR:	13 channels	CMY:	10 channels

02) Press the **ENTER** button to confirm your choice. See pages 33–39 for the DMX channel modes.

6.6.5. Preset Color

In this menu you can choose a preset color mix.

01) Press the **UP/DOWN** buttons to select one of the 48 presets.

02) Press the **ENTER** button to confirm your choice.

6.6.6. Auto Programs

In this menu you can select a built-in auto program or a custom program. There are 10 uneditable auto programs and 2 custom programs, which can be edited in Edit menu. See **6.6.7. Edit** on page 27.

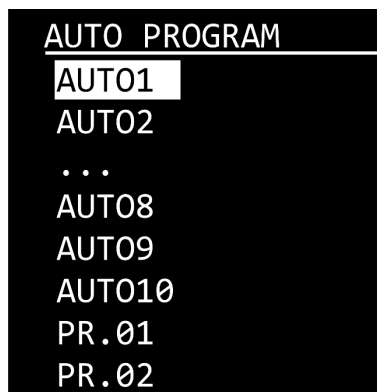

01) Press the **UP/DOWN** buttons to choose an auto or a custom program.

02) Press the **ENTER** button to confirm your choice.

03) If you have chosen one of the auto programs, after pressing the **ENTER** button you can additionally adjust the speed.

04) Press the **UP/DOWN** buttons to set the program speed. The adjustment range is between 0–255, from slow to fast.

05) Press the **ENTER** button to set the speed.

6.6.7. Edit

In this menu you can edit the custom programs thus creating your own custom show.

- 01) Press the **UP/DOWN** buttons to choose the custom program you want to edit (PROGRAM01–02).
- 02) Press the **ENTER** button to confirm the selection. Each custom program has 10 scenes, which can be edited:

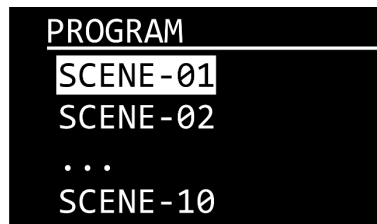

- 03) Press the **UP/DOWN** buttons to select the desired scene.
- 04) Press the **ENTER** button to enter the scene settings.
- 05) Press the **UP/DOWN** buttons to scroll through the 6 colors (RED, GREEN, BLUE, AMBER, LIME, CYAN), and the STROBE, TIME and FADE options.
- 06) Press the **ENTER** button to open the settings submenu.

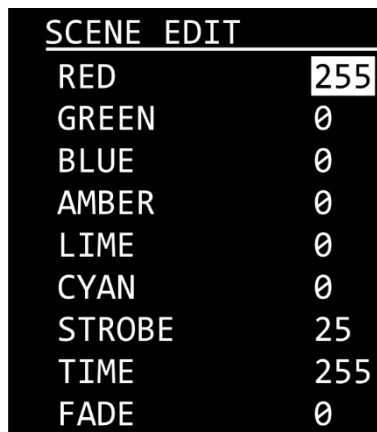

- 07) Press the **UP/DOWN** buttons to increase/decrease the values.
 - Color intensity (RED, GREEN, BLUE, AMBER, LIME, CYAN): the adjustment range is between 0-255, from low to high intensity.
 - STROBE frequency: the adjustment range is between 0–25, from OFF to high frequency.
 - TIME (duration of the scene): the adjustment range is between 0–255, from 0 to 255 seconds.
 - FADE (transition time between the scenes): the adjustment range is between 0–255, from 0 to 255 seconds.
- 08) Press the **ENTER** button to set the value and to move to the next setting.

Note: For each custom program you can create 30 scenes, which makes it possible to create 300 customized scenes in total.

6.6.7.1. Upload

In this submenu you can export the custom programs from the master device to the connected slave devices.

- 01) Select UPLOAD and press the **ENTER** button to open the submenu.
- 02) Enter the password, pressing the buttons in the following order: **UP, DOWN, UP, DOWN**.
- 03) Press the **ENTER** button to confirm. During upload, the light output will turn yellow and the display will show:



SEND . .

- 04) When the upload is finished, the display will show OK.
- 05) Press the **ENTER** button to confirm and exit the submenu.

6.6.8. Settings

In this menu you can adjust the device's settings. This menu requires the password. The default password is pressing the **UP/DOWN** buttons in the following order: **UP, DOWN, UP, DOWN**.

- 01) Enter the password to access the menu.
- 02) Press the **ENTER** button to confirm the password.
- 03) Press the **UP/DOWN** buttons to scroll through the following options:



SETTING
RESET
 DIMMER
 DMX ERROR
 PWM_RATE
 PERFORM
 DISP KEY
 DISP TIME
 COLOR CALIB

6.6.8.1. Reset

In this submenu you can restore the default factory settings and reset the custom programs.

- 01) Select RESET and press the **ENTER** button to open the submenu.
- 02) Enter the password, pressing the buttons in the following order: **UP, DOWN, UP, DOWN**.
- 03) Press the **ENTER** button to confirm. During reset the display will show:



RESET . .

- 04) When the resetting is finished, the display will show OK.
- 05) Press the **ENTER** button to confirm and exit the submenu.

6.6.8.2. Dimmer

In this submenu you can adjust the dimmer speed.

- 01) Select DIMMER and press the **ENTER** button to open the submenu.
- 02) Press the **UP/DOWN** buttons to choose one of the following options:
 - DIM 4: non-linear dimmer
 - OFF: linear dimmer
- 03) Press the **ENTER** button to confirm your choice.

6.6.8.3. DMX Error

In this submenu, you can determine the behavior of the device in case of a DMX failure.

- 01) Select DMX ERROR and press the **ENTER** button to open the submenu.
- 02) Press the **UP/DOWN** buttons to toggle between the following 2 options:
 - **SAVE**: in case of a DMX signal failure the device will use the last properly received DMX signal ensuring uninterrupted performance.
 - **BLACK**: in case of a DMX signal failure the device will black out the light output.
- 03) Press the **ENTER** button to confirm your choice.

6.6.8.4. PWM Rate

In this submenu you can set the PWM (Pulse Width Modulation) frequency.

- 01) Select PWM RATE and press the **ENTER** button to open the submenu.
- 02) Press the **UP/DOWN** buttons to choose the desired PWM frequency.
The available options are: 1200 Hz, 2400 Hz, 4000 Hz, 6000 Hz and 25000 Hz.
Note: The higher the PWM frequency, the lower the dimmer's grayscale.
- 03) Press the **ENTER** button to set the value.

6.6.8.5. Performance

In this menu you can set the performance of the Performer.

- 01) Select PERFORMANCE and press the **ENTER** button to open the submenu.
- 02) Press the **UP/DOWN** buttons to choose the desired performance mode. The available options are:
 - **LIVE**: Default mode. It provides a compromise between output quality and noise level.
 - **POWER**: Output-oriented mode. The device does not offer any consideration for noise level and operates at full power.
 - **STUDIO**: Noise level-oriented mode. It emits little noise and operates at moderate power level
- 03) Press the **ENTER** button to confirm your choice.

6.6.8.6. Disp Key (Display Lock)

In this menu you can activate the display lock.

Press the **UP/DOWN** buttons to toggle between ON and OFF.

- **ON**: display lock is on. The display turns off if no button is pressed within the preset amount of time. To access the main menu, you will need to enter the password. The default password is pressing the **UP, DOWN, UP, DOWN, ENTER**.
- **OFF**: the main menu remains unlocked after the display turns off.

Note: Deactivating the display lock does not affect the submenu items which by default require a password.

6.6.8.7. Disp Time (Display Time)

In this menu you can set the amount of time that needs to pass before the display turns off, if no button is pressed.

- 01) Press the **UP/DOWN** buttons to select one of the following options: 10 s/30 s/2 min/ON.
- 02) Press the **ENTER** button to confirm your choice.

6.6.8.8. Color Calibration

In this menu you can set/adjust the device's calibration settings.

- 01) Press the **UP/DOWN** buttons to choose the color calibration you want to set.
- 02) Press the **ENTER** button to confirm the selection.

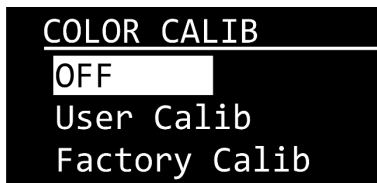

6.6.8.9. User Calibration

In this submenu you can adjust the device's calibration settings.

- 01) Select USER CALIB and press the **ENTER** button to open the submenu:



- 02) Press the **UP/DOWN** buttons to scroll through the 6 colors (RED, GREEN, BLUE, AMBER, LIME, CYAN) options.
- 03) Press the **ENTER** button to open the color submenu.

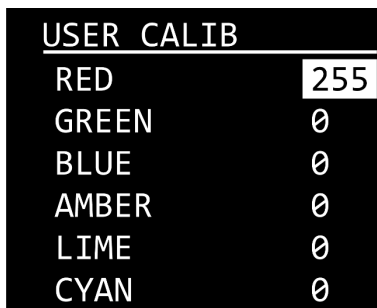

- 04) Press the **UP/DOWN** buttons to increase/decrease the values.
 - Color intensity (RED, GREEN, BLUE, AMBER, LIME, CYAN): the adjustment range is between 0-255, from low to high intensity.
- 05) Press the **ENTER** button to set the value and to move to the next setting.

6.6.9. Information

In this menu you can view the total operation time, current software version and the RDM details of the device.

- 01) Press the **UP/DOWN** buttons to choose FIXTURE HOURS, VERSION or RDM.
- 02) Press the **ENTER** button to confirm the selection.

6.6.9.1. Fixture Hours

In this submenu you can view the total operation time of the device.

6.6.9.2. Version

In this submenu you can view the current version of the installed firmware.

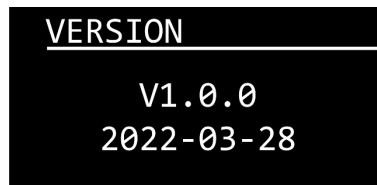

6.6.9.3. RDM

In this submenu you can view the RDM details of the device.

- 01) Press the **UP/DOWN** buttons to choose between the following options:
 - UID: the display shows the unique identification number of the device.
The model ID for the Performer Profile Zoom 150 Q6 is 0x2940C7
 - LABEL: the display shows the name of the device.
- 02) Press the **ENTER** button to confirm the selection.

6.6.10. CCT (Correlated Color Temperature Control)

In this menu you can calibrate the color temperature.

01) Press the **UP/DOWN** buttons to scroll through the following options:

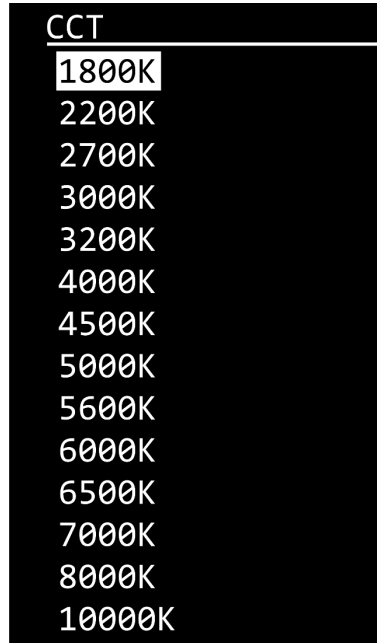

02) Press the **ENTER** button to confirm the selection.

6.6.11. Preset Color

In this menu you can choose a preset color mix.

Press the **UP/DOWN** buttons to select one of the 48 presets:



6.7. DMX Channels

6.7.1. 3 Channels, 8 Channels, 13 Channels, 20 Channels

3 CH (Basic)	8 CH (SSP)	13 CH (TOUR)	20 CH (TR16)	Function	Value	Setting
1	1	1	1	Master Dimmer	000-255	From low to high intensity (0-100 %)
			2	Dimmer Fine	000-255	From low to high intensity (0-100 %)
	2	2	3	Red	000-255	From low to high intensity (0-100 %)
			4	Red Fine	000-255	From low to high intensity (0-100 %)
	3	3	5	Green	000-255	From low to high intensity (0-100 %)
			6	Green Fine	000-255	From low to high intensity (0-100 %)
	4	4	7	Blue	000-255	From low to high intensity (0-100 %)
			8	Blue Fine	000-255	From low to high intensity (0-100 %)
	5	5	9	Amber	000-255	From low to high intensity (0-100 %)
			10	Amber Fine	000-255	From low to high intensity (0-100 %)
	6	6	11	Lime	000-255	From low to high intensity (0-100 %)
			12	Lime Fine	000-255	From low to high intensity (0-100 %)
	7	7	13	Cyan	000-255	From low to high intensity (0-100 %)
			14	Cyan Fine	000-255	From low to high intensity (0-100 %)
					000-010	No function
					011-015	Color 1 Loving Amber L176
					016-020	Color 2 Light Salmon R40
					021-025	Color 3 Scarlet L24
					026-030	Color 4 Flame Red L164
					031-035	Color 5 Easy White L747
					036-040	Color 6 Warm Peach R303
					041-045	Color 7 Dark Salmon L08
					046-050	Color 8 Sunset Red L25
					051-055	Color 9 Medium Bastard Amber L04
					056-060	Color 10 CID(To Tungsten) L237
					061-065	Color 11 Soft Golden Amber R321
					066-070	Color 12 Urban Sodium L652
					071-075	Color 13 LCT Yellow(Y1) L212
					076-080	Color 14 LEE Yellow L765
					081-085	Color 15 Ice And A Slice L513
					086-090	Color 16 Spring Yellow L100
					091-095	Color 17 LEE Plus Green L244
					096-100	Color 18 CalColor 30 Green R4430
					101-105	Color 19 Fern Green L122
					106-110	Color 20 Dark Yellow Green L90
					111-115	Color 21 LEE Fluorescent 3600 K L243
					116-120	Color 22 Turquoise R92
					121-125	Color 23 Kelly Green R94
					126-130	Color 24 Forest Green L327
					131-135	Color 25 Cosmetic Aqua Blue L191
					136-140	Color 26 Steel Green L728
					141-145	Color 27 Steel Blue L117
					146-150	Color 28 Special Steel Blue L354
					151-155	Color 29 Paler Lavender L53
					156-160	Color 30 New Colour Blue L501
					161-165	Color 31 Dark Steel Blue L174
					166-170	Color 32 Daylight Blue L165
					171-175	Color 33 Pale Lavender L136
					176-180	Color 34 Surprise Pink L194
					181-185	Color 35 Pale Violet L142
					186-190	Color 36 Perfect Lavender L700

3 CH (Basic)	8 CH (SSP)	13 CH (TOUR)	20 CH (TR16)	Function	Value	Setting	
					191-195	Color 37 Light Pink L35	
					196-200	Color 38 Pretty'n Pink L794	
					201-205	Color 39 Follies Pink L328	
					206-210	Color 40 Magical Magenta L795	
					211-215	Color 41 Pale Rose L154	
					216-220	Color 42 Smokey Pink L127	
					221-225	Color 43 Flesh Pink L192	
					226-230	Color 44 Special Rose Pink L332	
					231-235	Color 45 Moroccan Pink L790	
					236-240	Color 46 Pink L157	
					241-245	Color 47 Cherry Rose R332	
					246-250	Color 48 Cool LED Bright Pink L128	
					251-255	No function	
3		9	16	CCT	000-009	No function	
					010	1800 K	
					025	2200 K	
					040	2700 K	
					055	3000 K	
					070	3200 K	
					085	4000 K	
					100	4500 K	
					115	5000 K	
					130	5600 K	
					145	6000 K	
					160	6500 K	
					175	7000 K	
					190	8000 K	
					205	10000 K	
255	10000 K						
		10	17	Auto Programs	000-040	No function	
					041-050	Auto 1	
					051-060	Auto 2	
					061-070	Auto 3	
					071-080	Auto 4	
					081-090	Auto 5	
					091-100	Auto 6	
					101-110	Auto 7	
					111-120	Auto 8	
					121-130	Auto 9	
					131-140	Auto 10	
					141-150	Custom program 1	Use Edit menu to manually set Time and Fade
					151-160	Custom program 2	
					161-255	No Function	
		11	18	Speed	000-255	Program speed adjustment, from slow to fast	
	8	12	19	Strobe	000-009	No function	
					010-099	Strobe, from low to high frequency (0-25 Hz)	
					100-109	No function	
					110-179	Lightning strobe, from low to high frequency (0-25 Hz)	
					180-189	No function	
					190-255	Random strobe, from low to high frequency (0-25 Hz)	
		13	20	Control Mode	000-010	No Function	
					011-060	Reserved	
					061-070	Live	
					071-080	Studio	
					081-090	Power	
					091-100	Reserved	

3 CH (Basic)	8 CH (SSP)	13 CH (TOUR)	20 CH (TR16)	Function	Value	Setting
					101-110	Dimmer Off
					111-120	Dimmer Mode 4
					121-150	Reserved
					151-160	1200 Hz
					161-170	2400 Hz
					171-180	4000 Hz
					181-190	6000 Hz
					191-200	25000 Hz
					201-210	All Reset
					211-255	Reserved

Note:

- Make sure that Master Dimmer channel is open, to see the light output.
- Make sure that Color Presets or Built-in Programs or Red, Green, Blue, Amber, Lime and Cyan channels are open, if you want to use the Strobe channel.
- Make sure that Color Presets and Built-in Programs channels are closed, if you want to use Red, Green, Blue, Amber, Lime and Cyan channels.
- Make sure that Built-in Programs channel is closed, if you want to use Color Presets channel.
- Make sure that Built-in Programs channel is open, if you want to use Program Speed channel.

6.7.2. 7 Channels

7 CH (HSIC)	Function	Value	Setting
1	Intensity	000–255	From low to high intensity (0–100 %)
2	Hue	000–255	From low to high intensity (0–100 %)
3	Hue Fine	000–255	From low to high intensity (0–100 %)
4	Saturation	000–255	From low to high intensity (0–100 %)
5	CCT	000–009	No function
		010	1800 K
		025	2200 K
		040	2700 K
		055	3000 K
		070	3200 K
		085	4000 K
		100	4500 K
		115	5000 K
		130	5600 K
		145	6000 K
		160	6500 K
		175	7000 K
		190	8000 K
205	10000 K		
255	10000 K		
6	Strobe	000–009	No function
		010–099	Strobe, from low to high frequency (0–25 Hz)
		100–109	No function
		110–179	Lightning strobe, from low to high frequency (0–25 Hz)
		180–189	No function
		190–255	Random strobe, from low to high frequency (0–25 Hz)
7	Control Mode	000–010	No Function
		011–060	Reserved
		061–070	Live
		071–080	Studio
		081–090	Power
		091–100	Reserved
		101–110	Dimmer Off
		111–120	Dimmer Mode 4
		121–150	Reserved
		151–160	1200 Hz
		161–170	2400 Hz
		171–180	4000 Hz
		181–190	6000 Hz
		191–200	25000 Hz
		201–210	All Reset
		211–255	Reserved

Note:

- Make sure that Intensity channel is open, to see the light output.
- Make sure that Intensity, Hue and Saturation channels are open, if you want to use the Strobe channel.

6.7.3. 10 Channels

10 CH (CMY)	Function	Value	Setting		
1	Master Dimmer	000-255	From low to high intensity (0-100 %)		
2	Cyan	000-255	From low to high intensity (0-100 %)		
3	Magenta	000-255	From low to high intensity (0-100 %)		
4	Yellow	000-255	From low to high intensity (0-100 %)		
2	Color Presets	000-010	No function		
		011-015	Color 1	Loving Amber	L176
		016-020	Color 2	Light Salmon	R40
		021-025	Color 3	Scarlet	L24
		026-030	Color 4	Flame Red	L164
		031-035	Color 5	Easy White	L747
		036-040	Color 6	Warm Peach	R303
		041-045	Color 7	Dark Salmon	L08
		046-050	Color 8	Sunset Red	L25
		051-055	Color 9	Medium Bastard Amber	L04
		056-060	Color 10	CID(To Tungsten)	L237
		061-065	Color 11	Soft Golden Amber	R321
		066-070	Color 12	Urban Sodium	L652
		071-075	Color 13	LCT Yellow(Y1)	L212
		076-080	Color 14	LEE Yellow	L765
		081-085	Color 15	Ice And A Slice	L513
		086-090	Color 16	Spring Yellow	L100
		091-095	Color 17	LEE Plus Green	L244
		096-100	Color 18	CalColor 30 Green	R4430
		101-105	Color 19	Fern Green	L122
		106-110	Color 20	Dark Yellow Green	L90
		111-115	Color 21	LEE Fluorescent 3600 K	L243
		116-120	Color 22	Turquoise	R92
		121-125	Color 23	Kelly Green	R94
		126-130	Color 24	Forest Green	L327
		131-135	Color 25	Cosmetic Aqua Blue	L191
		136-140	Color 26	Steel Green	L728
		141-145	Color 27	Steel Blue	L117
		146-150	Color 28	Special Steel Blue	L354
		151-155	Color 29	Paler Lavender	L53
		156-160	Color 30	New Colour Blue	L501
		161-165	Color 31	Dark Steel Blue	L174
		166-170	Color 32	Daylight Blue	L165
		171-175	Color 33	Pale Lavender	L136
		176-180	Color 34	Surprise Pink	L194
		181-185	Color 35	Pale Violet	L142
		186-190	Color 36	Perfect Lavender	L700
		191-195	Color 37	Light Pink	L35
		196-200	Color 38	Pretty'n Pink	L794
		201-205	Color 39	Follies Pink	L328
		206-210	Color 40	Magical Magenta	L795
		211-215	Color 41	Pale Rose	L154
		216-220	Color 42	Smokey Pink	L127
		221-225	Color 43	Flesh Pink	L192
		226-230	Color 44	Special Rose Pink	L332
		231-235	Color 45	Moroccan Pink	L790
236-240	Color 46	Pink	L157		

10 CH (CMY)	Function	Value	Setting	
		241-245	Color 47 Cherry Rose R332	
		246-250	Color 48 Cool LED Bright Pink L128	
		251-255	No function	
6	CCT	000-009	No function	
		010	1800 K	
		025	2200 K	
		040	2700 K	
		055	3000 K	
		070	3200 K	
		085	4000 K	
		100	4500 K	
		115	5000 K	
		130	5600 K	
		145	6000 K	
		160	6500 K	
		175	7000 K	
		190	8000 K	
205	10000 K			
255	10000 K			
7	Auto Programs	000-040	No function	
		041-050	Auto 1	
		051-060	Auto 2	
		061-070	Auto 3	
		071-080	Auto 4	
		081-090	Auto 5	
		091-100	Auto 6	
		101-110	Auto 7	
		111-120	Auto 8	
		121-130	Auto 9	
		131-140	Auto 10	
		141-150	Custom program 1	Use Edit menu to manually set
		151-160	Custom program 2	Time and Fade
		161-255	No Function	
8	Speed	000-255	Program speed adjustment, from slow to fast	
9	Strobe	000-009	No function	
		010-099	Strobe, from low to high frequency (0-25 Hz)	
		100-109	No function	
		110-179	Lightning strobe, from low to high frequency (0-25 Hz)	
		180-189	No function	
		190-255	Random strobe, from low to high frequency (0-25 Hz)	
10	Control Mode	000-010	No Function	
		011-060	Reserved	
		061-070	Live	
		071-080	Studio	
		081-090	Power	
		091-100	Reserved	
		101-110	Dimmer Off	
		111-120	Dimmer Mode 4	
		121-150	Reserved	
		151-160	1200 Hz	
		161-170	2400 Hz	
		171-180	4000 Hz	
		181-190	6000 Hz	

10 CH (CMY)	Function	Value	Setting
		191-200	25000 Hz
		201-210	All Reset
		211-255	Reserved

Note:

- Make sure that Master Dimmer channel is open, to see the light output.
- Make sure that Color Presets or Built-in Programs or Cyan, Magenta and Yellow channels are open, if you want to use the Strobe channel.
- Make sure that Color Presets and Built-in Programs channels are closed, if you want to use Cyan, Magenta or Yellow channels.
- Make sure that Built-in Programs channel is closed, if you want to use Color Presets channel.
- Make sure that Built-in Programs channel is open, if you want to use Program Speed channel.

6.8. RDM Information

This device supports RDM. Refer to **6.8.2. Supported RDM PIDs (Parameter IDs)** for more information.

6.8.1. RDM Details

- Responder: 29B4:0C7xxxxx
- Manufacturer's ID: Showtec (Highlite International B.V.)
- Manufacturer Label: Showtec
- Model Description: Performer Profile Zoom 150 Q6
- Model ID: 199
- Device Label: Performer Profile Zoom 150 Q6

Note:

An RDM responder ID consists of 3 parts:

- 1st part – 4 digits – Manufacturer's ID
- 2nd part – 3 digits – Model ID
- 3rd part – 5 digits – Unique ID

The RDM responder IDs of all products of Highlite International start with the same 4 digits. The first 7 digits of the RDM responder ID for each model are the same. The last 5 digits are different for each device.

6.8.2. Supported RDM PIDs (Parameter IDs)

Parameter ID	Value	Required	GET	SET
DISC_UNIQUE_BRANCH	0x0001	*		
DISC_MUTE	0x0002	*		
DISC_UN_MUTE	0x0003	*		
COMMS_STATUS	0x0015		*	*
STATUS_MESSAGES	0x0030		*	
STATUS_ID_DESCRIPTION	0x0031		*	
CLEAR_STATUS_ID	0x0032			*
SUPPORTED_PARAMETERS	0x0050	*	*	
DEVICE_INFO	0x0060	*	*	
DEVICE_MODEL_DESCRIPTION	0x0080		*	
MANUFACTURER_LABEL	0x0081		*	
DEVICE_LABEL	0x0082		*	*
FACTORY_DEFAULTS	0x0090		*	*
LANGUAGE_CAPABILITIES	0x00A0		*	
LANGUAGE	0x00B0		*	*
SOFTWARE_VERSION_LABEL	0x00C0	*	*	
DMX_PERSONALITY	0x00E0		*	*
DMX_PERSONALITY_DESCRIPTION	0x00E1		*	
DMX_START_ADDRESS	0x00F0	*	*	*
SLOT_INFO	0x0120		*	
SLOT_DESCRIPTION	0x0121		*	
SENSOR_DEFINITION	0x0200		*	
SENSOR_VALUE	0x0201		*	*
RECORD_SENSORS	0x0202			*
CURVE	0x0343		*	*
CURVE_DESCRIPTION	0x0344	*	*	
MODULATION_FREQUENCY	0x0347		*	*
MODULATION_FREQUENCY_DESCRIPTION	0x0348	*	*	
IDENTIFY_DEVICE	0x1000	*	*	*

7. Troubleshooting

This troubleshooting guide contains solutions to problems which can be carried out by an ordinary person. The device does not contain user-serviceable parts.

Unauthorized modifications to the device will render the warranty void. Such modifications may result in injuries and material damage.

Refer servicing to instructed or skilled persons. Contact your Highlite International dealer in case the solution is not described in the table.

Problem	Probable cause(s)	Solution
The device does not function at all	No power to the device	<ul style="list-style-type: none"> Check if power is switched on and cables are plugged in
	Internal fuse is blown	<ul style="list-style-type: none"> Disconnect the device and contact your Highlite International dealer
The device responds erratically	The factory settings of the device are changed	<ul style="list-style-type: none"> Reset the device's parameters to the default factory settings. See 6.6.8.1. Reset on page 28
The device does not respond to DMX control	The controller is not connected	<ul style="list-style-type: none"> Connect the controller
	The signal is reversed. The 5-pin DMX OUT of the controller does not match the DMX IN of the device	<ul style="list-style-type: none"> Install a phase-reversing cable between the controller and the device
	The controller is defective	<ul style="list-style-type: none"> Try using another controller
The device responds erratically to DMX control	Bad data link connection	<ul style="list-style-type: none"> Examine connections and cables. Correct poor connections. Repair or replace damaged cables
	The data link is not terminated with a 120 Ω termination plug	<ul style="list-style-type: none"> Insert a termination plug in the DMX OUT connector of the last device on the link
	Incorrect addressing	<ul style="list-style-type: none"> Check address settings and correct, if necessary
	In case of a setup with multiple devices, one of the devices is defective and disturbs data transmission on the link	<ul style="list-style-type: none"> To find out the defective device, bypass one device at a time until normal operation is restored
No light or LEDs cut out intermittently	LEDs are damaged	<ul style="list-style-type: none"> Disconnect the device and contact your Highlite International dealer
	The power supply settings do not match local AC voltage and frequency	<ul style="list-style-type: none"> Disconnect the device. Check the settings and correct, if necessary

8. Maintenance

8.1. Safety Instructions for Maintenance



DANGER
Electric shock caused by dangerous voltage inside

Disconnect power supply before servicing or cleaning.

8.2. Preventive Maintenance



Attention
Before each use, examine the device visually for any defects.

Make sure that:

- All screws used for installing the device or parts of the device are tightly fastened and are not corroded.
- The safety devices are not damaged.
- There are no deformations on housings, fixations and installation points.
- The lens is not cracked or damaged.
- The power cables are not damaged and do not show any material fatigue.

8.2.1. Basic Cleaning Instructions

The external lens of the device must be cleaned periodically in order to optimize the light output. The cleaning schedule depends on the conditions at the site where the device is installed. When smoke or fog machines are used at the site, the device will need more frequent cleaning. On the other hand, if the device is installed in well-ventilated area, it will need less frequent cleaning. To establish a cleaning schedule, examine the device at regular intervals during the first 100 hours of operation.

To clean the device, follow the steps below:

- 01) Disconnect the device from the electrical power supply.
- 02) Allow the device to cool down for at least 15 minutes.
- 03) Remove the dust collected on the external surface with dry compressed air and a soft brush.
- 04) Clean the lens with a damp cloth. Use a mild detergent solution.
- 05) Dry the lens carefully with a lint-free cloth.
- 06) Clean the DMX and other connections with a damp cloth.



Attention

- Do not immerse the device in liquid.
- Do not use alcohol or solvents.
- Make sure that the connections are fully dry before connecting the device to the power supply and to other devices.

8.3. Corrective Maintenance

The device does not contain user-serviceable parts. Do not open the device and do not modify the device.

Refer repairs and servicing to instructed or skilled persons. Contact your Highlite International dealer for more information.

9. Deinstallation, Transportation and Storage

9.1. Instructions for Deinstallation



WARNING

Incorrect deinstallation can cause serious injuries and damage of property.

- Let the device cool down before dismounting.
- Disconnect power supply before deinstallation.
- Always observe the national and site-specific regulations during deinstallation and derigging of the device.
- Wear personal protective equipment in compliance with the national and site-specific regulations.

9.2. Instructions for Transportation

- Use the original packaging to transport the device, if possible.
- Always observe the handling instructions printed on the outer carton box, for example: "Handle with care", "This side up", "Fragile".

9.3. Storage

- Clean the device before storing. Follow the cleaning instructions in chapter **8.2.1. Basic Cleaning Instructions** on page 43.
- Store the device in the original packaging, if possible.

10. Disposal

Correct disposal of this product



Waste Electrical and Electronic Equipment

This symbol on the product, its packaging or documents indicates that the product shall not be treated as household waste. Dispose of this product by handing it to the respective collection point for recycling of electrical and electronic equipment. This is to avoid environmental damage or personal injury due to uncontrolled waste disposal. For more detailed information about recycling of this product contact the local authorities or the authorized dealer.

11. Approval



Check the respective product page on the website of Highlite International (www.highlite.com) for an available declaration of conformity.



©2025 Showtec