

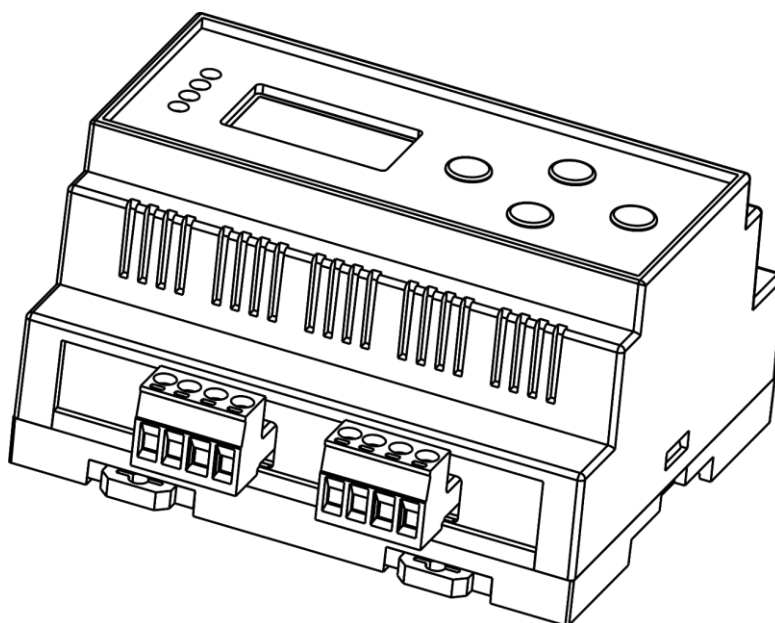

USER MANUAL



ENGLISH

LED SPI-2 Install

V1

Product code: 50412

Preface

Thank you for purchasing this Showtec product.

The purpose of this user manual is to provide instructions for the correct and safe use of this product.

Keep the user manual for future reference as it is an integral part of the product. The user manual shall be stored at an easily accessible location.

This user manual contains information concerning:

- Safety instructions
- Intended and non-intended use of the device
- Installation and operation of the device
- Maintenance procedures
- Troubleshooting
- Transport, storage and disposal of the device

Non-observance of the instructions in this user manual may result in serious injuries and damage of property.

©2021 Showtec. All rights reserved.

No part of this document may be copied, published or otherwise reproduced without the prior written consent of Highlite International.

Design and product specifications are subject to change without prior notice.

For the latest version of this document or for other language versions, please visit our website www.highlite.com or contact us at service@highlite.com.

Highlite International and its authorized service providers are not liable for any injury, damage, direct or indirect loss, consequential or economic loss or any other loss arising from the use of, or inability to use or reliance on the information contained in this document.

Table of contents

1. Introduction	4
1.1. Before Using the Product	4
1.2. Intended Use	4
1.3. Text Conventions	4
1.4. Symbols and Signal Words.....	5
1.5. Symbols on the Information Label	5
2. Safety	6
2.1. Warnings and Safety Instructions	6
2.2. Requirements for the User.....	7
3. Description of the Device	8
3.1. Front View	8
3.2. Product Specifications	9
3.3. Dimensions.....	10
4. Installation	11
4.1. Safety Instructions for Installation	11
4.2. Installation Site Requirements	11
4.3. DIN Rail Mounting.....	11
4.4. Connecting to Power Supply	12
5. Setup	13
5.1. Warnings and Precautions	13
5.2. DMX Connection.....	13
5.2.1. DMX-512 Protocol	13
5.2.2. DMX cable connection.....	13
5.2.3. DMX Cables.....	14
5.2.4. Setup LED SPI-2 (DMX).....	14
5.2.5. DMX Addressing.....	15
5.3. Art-NET Connection	15
5.3.1. Setup LED SPI-2 (Art-Net/Kling-Net)	15
5.3.2. Connecting to a Network	16
5.3.2.1. Art-Net Settings	16
5.3.2.2. Kling-Net Settings.....	16
5.4. How To Make a Data Cable	17
6. Operation	18
6.1. Safety Instructions for Operation	18
6.2. Control Modes	18
6.3. Control Panel	19
6.4. Start-up.....	19
6.5. Menu Overview	20
6.6. Main Menu Options	21
6.6.1. Operating Mode.....	22
6.6.2. Personality	22
6.6.3. Port Setup	22
6.6.3.1. Output 1 / Output 2	23
6.6.4. Stand-alone Mode	23
6.6.4.1. User Color.....	24
6.6.4.2. Preset Color	24
6.6.4.3. Automatic Programs	25
6.6.5. Output Protocol	25
6.6.6. IP Mode	26
6.6.6.1. DHCP IP	26
6.6.6.2. Static IP.....	26
6.6.7. Netmask.....	27
6.6.8. LCD Backlight	27

6.6.9.	Display Invert	28
6.6.10.	Factory Reset.....	28
6.6.11.	Firmware version	29
6.7.	DMX Channels	30
6.7.1.	17 Channels	30
6.7.2.	34 Channels	31
6.7.3.	510 Channels	33
6.8.	UID number.....	33
7.	Troubleshooting	34
8.	Maintenance	35
8.1.	Safety Instructions for Maintenance	35
8.2.	Preventive Maintenance	35
8.2.1.	Basic Cleaning Instructions	36
8.3.	Corrective Maintenance	36
9.	Deinstallation, Transportation and Storage	37
9.1.	Instructions for Deinstallation.....	37
9.2.	Instructions for Transportation	37
9.3.	Storage	37
10.	Disposal	37
11.	Approval.....	37

1. Introduction

1.1. Before Using the Product



Important

Read and follow the instructions in this user manual before installing, operating or servicing this product.

The manufacturer will not accept liability for any resulting damages caused by the non-observance of this manual.

After unpacking, check the contents of the box. If any parts are missing or damaged, contact your Highlite International dealer.

Your shipment includes:

- Showtec LED SPI-2 Install
- User manual

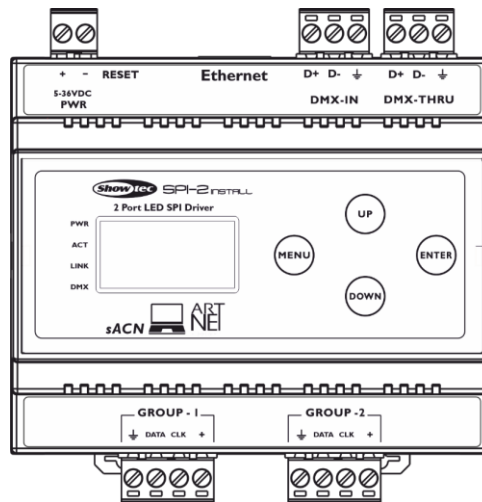

Fig. 01

1.2. Intended Use

This device is intended for professional use as a DMX to SPI converter. It is suitable only for indoor installation. This device is not suitable for households and for general lighting.

Any other use, not mentioned under intended use, is regarded as non-intended and incorrect use.

1.3. Text Conventions

Throughout the user manual the following text conventions are used:

- Buttons: All buttons are in bold lettering, for example "Press the **UP/DOWN** buttons"
- References: References to chapters and parts of the device are in bold lettering, for example: "Refer to **2. Safety**", "turn the **adjustment screw (02)**"
- 0–255: Defines a range of values
- Notes: **Note:** (in bold lettering) is followed by useful information or tips

1.4. Symbols and Signal Words

Safety notes and warnings are indicated throughout the user manual by safety signs.

Always follow the instructions provided in this user manual.

**DANGER**

Indicates an imminently hazardous situation which, if not avoided, will result in death or serious injury.

**WARNING**

Indicates an imminently hazardous situation which, if not avoided, could result in death or serious injury.

**CAUTION**

Indicates a potentially hazardous situation, which, if not avoided, may result in minor or moderate injury.

**Attention**

Indicates important information for the correct operation and use of the product.

**Important**

Read and observe the instructions in this document.



Provides important information about the disposal of this product.



1.5. Symbols on the Information Label

This product is provided with an information label. The information label is located on the bottom plate of the device.

The information label contains the following symbols:



This device is designed for indoor use.



This device is IEC protection class III.



This device shall not be treated as household waste.



Read and observe the instructions in this document.

2. Safety

**Important**

Read and follow the instructions in this user manual before installing, operating or servicing this product.

The manufacturer will not accept liability for any resulting damages caused by the non-observance of this manual.

2.1. Warnings and Safety Instructions

**Attention****Power supply**

This device falls under IEC protection class III. This device shall be connected to an external power supply.

- Before connecting the device to the external power supply, make sure that the current, voltage and frequency match the input voltage, current and frequency specified on the information label on the device.
- Make sure that the cross-sectional area of the power cable is sufficient for the required power consumption of the device.

**Attention****General safety**

- Do not block the ventilation openings. Without proper heat dissipation and air circulation, the internal components may overheat. This can result in product damage.
- Do not shake the device. Avoid brute force when installing or operating the device.

**Attention****For professional use only**

This device shall be used only for the purposes it is designed for.

This device is designed to be used as a professional DMX trigger/recorder. It is suitable for indoor installation in an electrical enclosure. Any incorrect use may lead to hazardous situations and result in injuries and material damage.

- This device is not suitable for households.
- This device does not contain user-serviceable parts. Unauthorized modifications to the device will render the warranty void. Such modifications may result in injuries and material damage.



Attention

Do not expose the device to conditions that exceed the rated IP class conditions.

This device is IP20 rated. IP (Ingress Protection) 20 class provides protection against solid objects greater than 12 mm, such as fingers, and no protection against harmful ingress of water.

2.2. Requirements for the User

This product may be used by ordinary persons. Maintenance, installation and service shall be carried out only by instructed or skilled persons. Contact your Highlite International dealer for more information.

Instructed persons have been instructed and trained by a skilled person, or are supervised by a skilled person, for specific tasks and work activities associated with the service of this product, so that they can identify risks and take precautions to avoid them.

Skilled persons have training or experience, which enables them to recognize risks and to avoid hazards associated with the service of this product.

Ordinary persons are all persons other than instructed persons and skilled persons. Ordinary persons include not only users of the product but also any other persons that may have access to the device or who may be in the vicinity of the device.

3. Description of the Device

The Showtec SPI-2 Install is a compact SPI controller for your digital LED strips. The Din-rail housing is ideal for fixed-installation purposes. All connections are easy connectable with plug-in Phoenix terminals. Simply use DMX, Art-Net or sACN for controlling most common types of LEDs (WS, TM, APA family). All settings can be done by the easy-to-use menu on the graphic display and buttons on the front or via the remote web interface which can be accessed within the network. Each group output can handle up to 960 pixels. The din-rail mounted SPI-2 converts DMX, Art-Net or sACN to SPI and is ideal for network system integration projects.

3.1. Front View

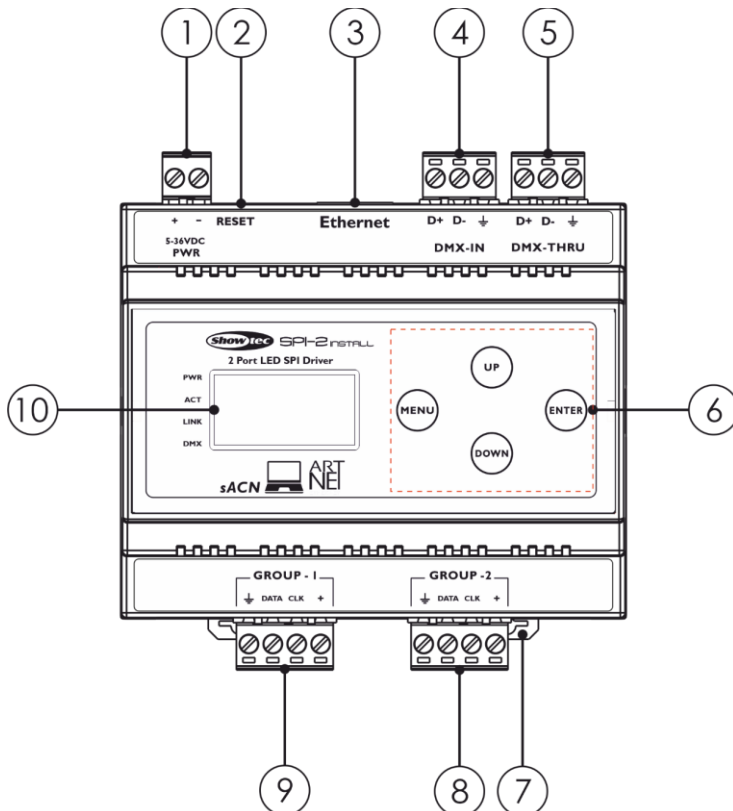

Fig. 02

- 01) DC IN: Phoenix terminal connector (+, -, 5-36V)
- 02) Reset
- 03) Ethernet connector
- 04) DMX IN: Phoenix terminal connector (Data +, Data -, Ground)
- 05) DMX THRU: Phoenix terminal connector (Data +, Data -, Ground)
- 06) Control buttons (Menu, Up, Down, Enter)
- 07) DIN rail lock
- 08) GROUP 2: PIXEL OUTPUT: (Ground, Data, CLK, +)
- 09) GROUP 1: PIXEL OUTPUT: (Ground, Data, CLK, +)
- 10) OLED display

3.2. Product Specifications

Model:	Showtec LED SPI-2 Install
Power supply:	5-36V DC
Power consumption:	6 W
Housing:	Grey plastic
DMX connections:	Ethernet / RJ45
5-36V DC IN:	2-pin Phoenix terminal (maximum cable gauge: 2,0525 mm)
PWM OUT:	2x 4-pin Phoenix terminal (maximum cable gauge: 2,0525 mm)
	Wide range input voltage 2 x 960 pixel outputs Remote setup interface Art-Net, sACN and DMX512 control DIN EN43880 form factor DIN EN60715 rail system (DIN Rail Spacing 35 mm)
Input Protocol:	DMX, Ethernet
Output Protocol:	SPI
SPI control:	WS2811/WS2812B, PSK6812, P943, UCS9812
Pixel Count:	960 max per group output
Pixel Groups:	1, 2
DMX Channels	512
IP rating:	IP20
Protection class:	II
Operation temperature:	-10 °C to +55 °C
Storage temperature:	-20 °C to +70 °C
Dimensions:	105 x 87 x 58 mm (LxWxH)
Weight:	0,185 kg

3.3. Dimensions

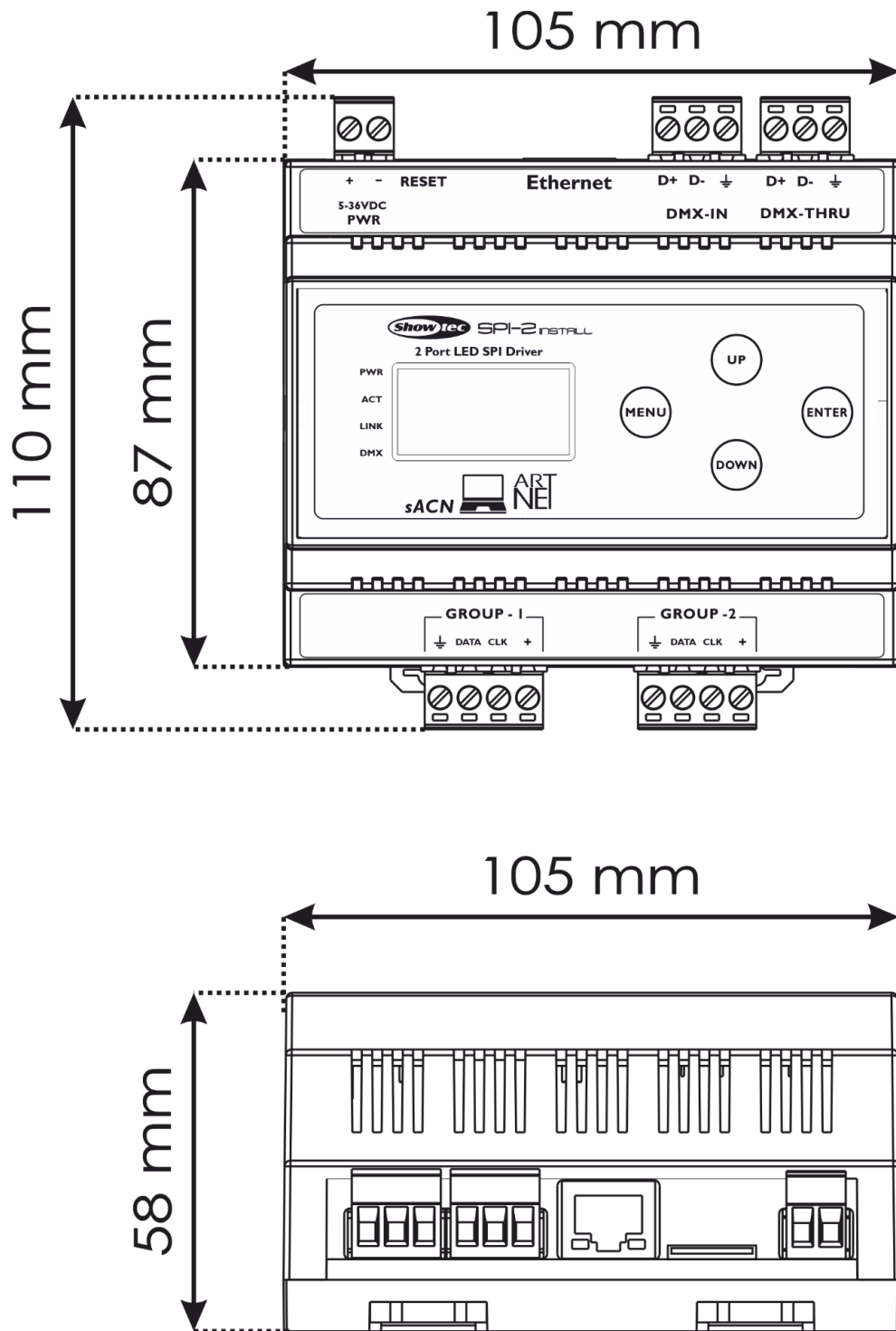

Fig. 03

4. Installation

4.1. Safety Instructions for Installation



WARNING

Incorrect installation can cause serious injuries and damage of property.

The installation of this device shall be carried out only by instructed or skilled persons.

Before installing the device, make sure that the electrical enclosure, where the device will be mounted, is disconnected from power supply.

4.2. Installation Site Requirements

- The device must be installed only indoors.
- The device can be mounted on a 35-mm DIN rail.
- The maximum ambient temperature $t_a = 40\text{ °C}$ must never be exceeded.
- The relative humidity must not exceed 50 % with an ambient temperature of 40 °C.

4.3. DIN Rail Mounting

The device can be mounted on a 35-mm DIN rail.

Make sure that the DIN rail is sufficiently secured to prevent it from becoming unstable or falling off.

To mount the device on a 35-mm DIN rail, follow the steps below:

- 01) Position the device on the DIN rail.
- 02) Push the **DIN rail locks (07)** to mount the device firmly on the DIN rail (see Fig. 04).

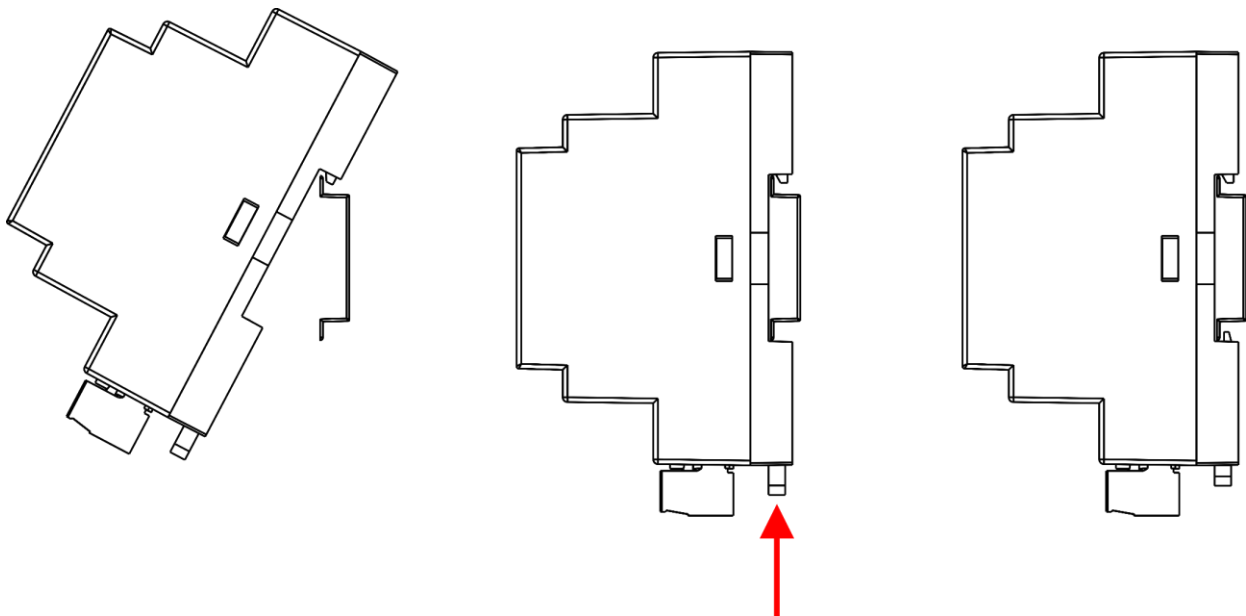

Fig. 04

4.4. Connecting to Power Supply



Attention
Power supply

This device falls under IEC protection class III. This device shall be connected to an external power supply.

- Before connecting the device to the external power supply, make sure that the current, voltage and frequency match the input voltage, current and frequency specified on the information label on the device.
- Make sure that the cross-sectional area of the power cable is sufficient for the required power consumption of the device.

01) Remove the **2-pin Phoenix terminal power connector IN (01)**.

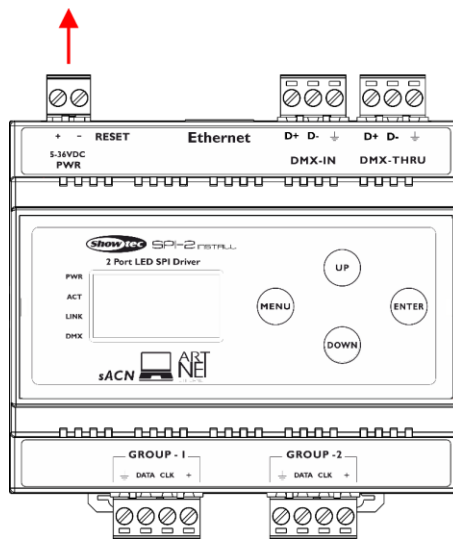

Fig. 05

02) Connect the external power supply to the Phoenix connector. Insert the cables correctly.

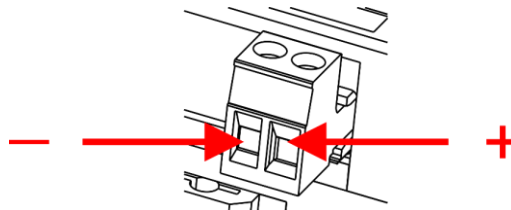

Fig. 06

- 03) Put the Phoenix connector back in the LED SPI-2 Install.
- 04) Install the LED SPI-2 Install on a DIN rail. See **4.3. DIN Rail Mounting** on page 11 for more information.
- 05) Connect the external power supply to the socket-outlet with its power plug.

5. Setup

5.1. Warnings and Precautions



Attention

Connect all data cables before supplying power.
Disconnect power supply before connecting or disconnecting data cables.

5.2. DMX Connection

5.2.1. DMX-512 Protocol

You need a DMX serial data link to run light shows of one or more devices using a DMX-512 controller or to run synchronized shows of two or more devices set in a master/slave operating mode.

The LED SPI-2 has 3-pin DMX signal IN and OUT connectors.

The pin assignment is as follows:

- 3-pin: pin 1 (ground), pin 2 (-), pin 3 (+)

Note:

- Maximum recommended DMX data link distance: 300 m

5.2.2. DMX cable connection

- 01) Remove the **3-pin Phoenix terminal DMX connector IN (04)** and the **3-pin Phoenix terminal DMX connector OUT (05)**.

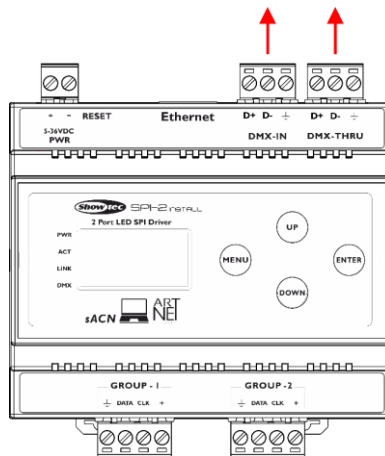

Fig. 07

- 02) Connect a DMX-512 light controller to the device's **3-pin Phoenix terminal DMX connector IN (04)** and connect light fixtures to the device's **3-pin Phoenix terminal DMX connector THRU (05)**.
- 03) Insert the cables correctly.

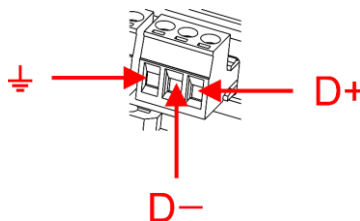

Fig. 08

5.2.3. DMX Cables

Shielded twisted-pair cables with 3-pin XLR connectors must be used for reliable DMX connection. You can purchase DMX cables directly from your Highlite International dealer or make your own cables.

If you use 3-pin XLR audio cables for DMX data transmission, this may lead to signal degradation and unreliable operation of the DMX network.

When you make your own DMX cables, make sure that you connect the pins and wires correctly as shown in Fig. 09.

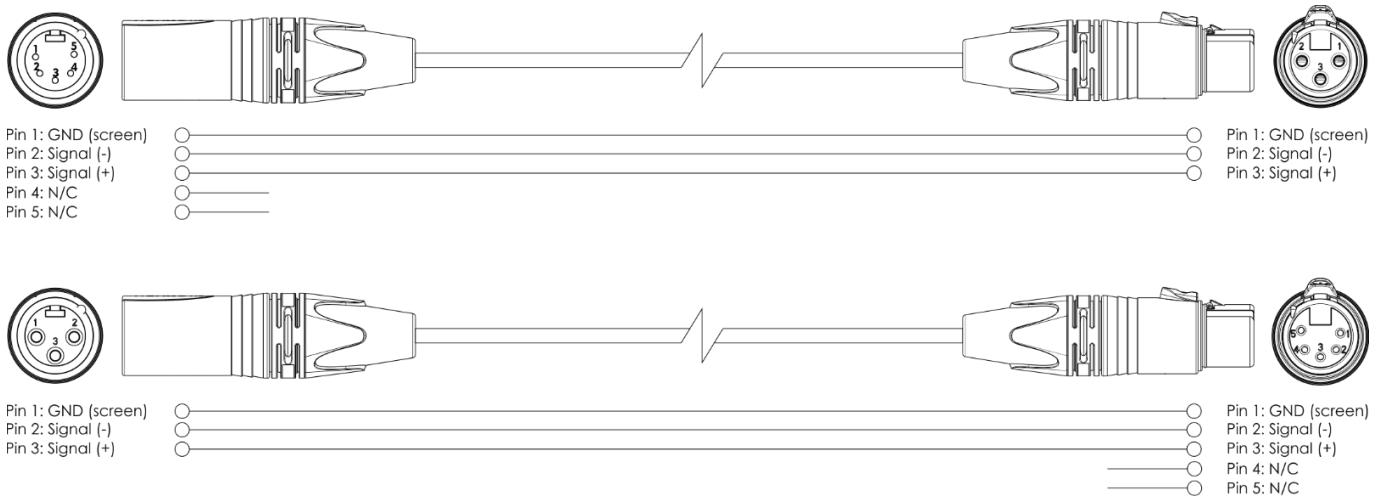

Fig. 09

5.2.4. Setup LED SPI-2 (DMX)

To connect multiple devices on one DMX data link, follow the steps below:

- 01) Use a 3-pin DMX cable to connect the DMX OUT connector of the lighting controller to the DMX IN connector of the first device.
- 02) Connect the first device's DMX OUT connector to the second device's DMX IN connector with a 3-pin/5-pin DMX cable.
- 03) Repeat step 2 to connect all devices in a daisy-chain as shown in Fig. 10.
- 04) Connect a DMX terminator (120 Ω resistor) to the DMX OUT connector of the last device on the data link.

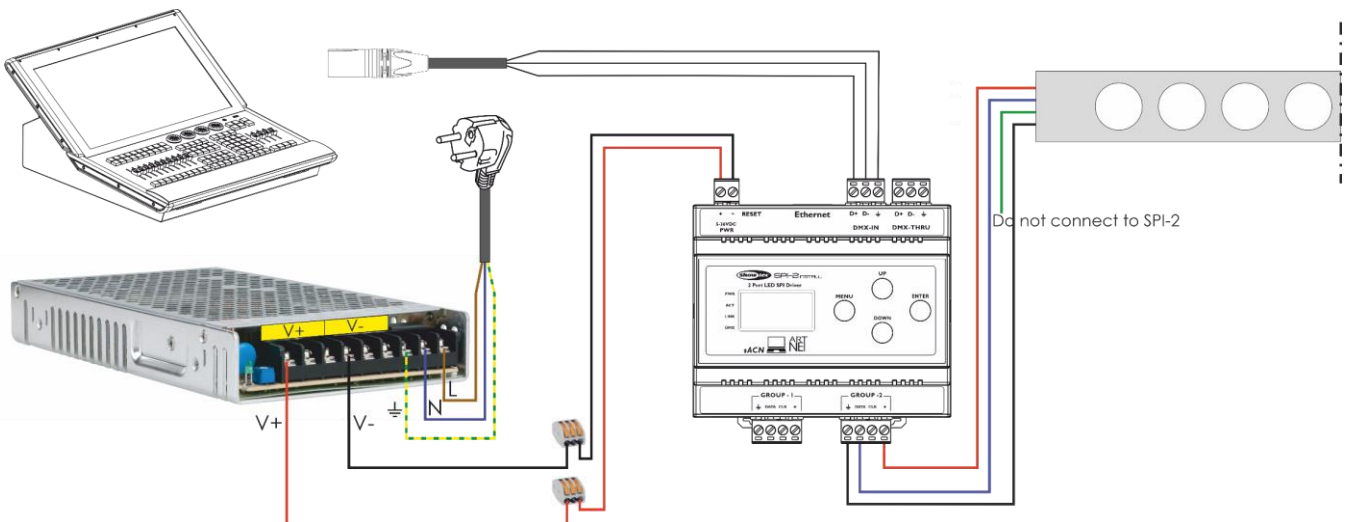

Fig. 10

5.2.5. DMX Addressing

In a setup with multiple devices, make sure that you set the DMX starting address of each device correctly. The LED SPI-2 Install has 3 personalities: 17 channels, 34 channels and 512 channels.

If you want to connect multiple devices on one data link and use them in 34-channel mode, for example, follow the steps below:

- 01) Set the starting address of the 1st device on the data link to 1 (001).
- 02) Set the starting address of the 2nd device on the data link to 35 (035), as $1 + 34 = 35$.
- 03) Set the starting address of the 3rd device on the data link to 79 (079) as $35 + 34 = 79$.
- 04) Continue assigning the starting addresses of the remaining devices by adding each time 34 to the previous number.

Make sure that you do not have any overlapping channels in order to control each Luna Four Bar 60 correctly. If two or more devices are addressed similarly, they will work similarly.

5.3. Art-NET Connection

5.3.1. Setup LED SPI-2 (Art-Net/Kling-Net)

- 01) Fasten the effect light to a DIN EN60715 rail system or mount it on flat surface.
- 02) Use a CAT-5/CAT-6 cable to connect the LED SPI-2 Install and other devices.
- 03) Connect your computer with installed Art-Net/Kling-Net software to the first device's RJ45 connector.
- 04) Supply electric power. Do not supply power before the whole system is set up and connected properly.

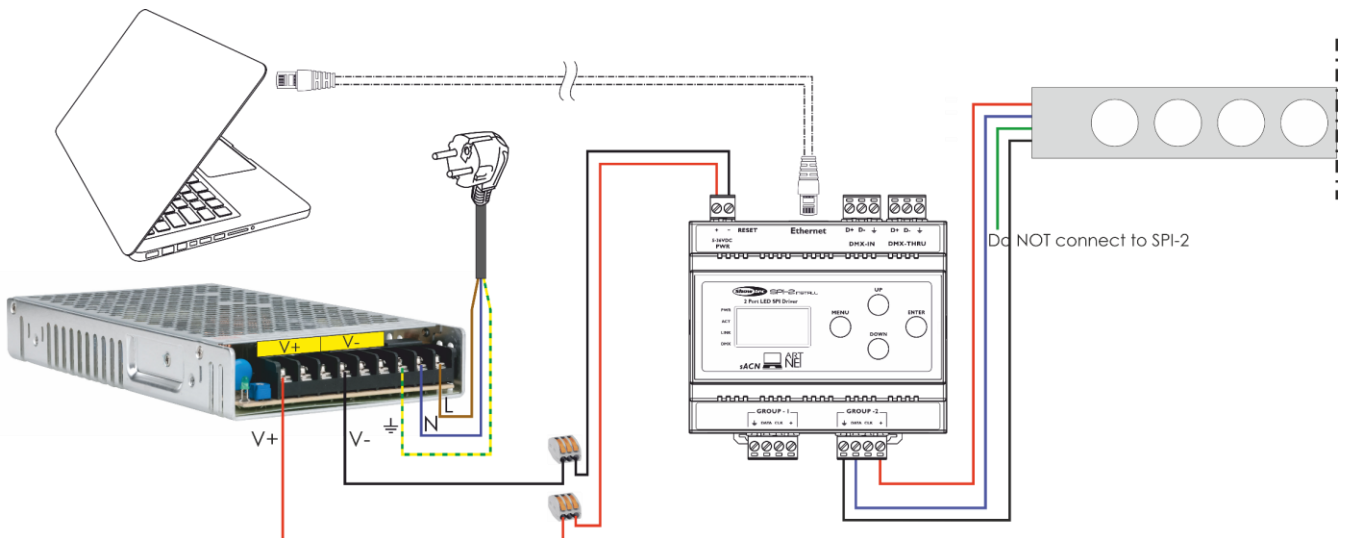

Fig. 11

Note: Link all cables before connecting electric power!

5.3.2. Connecting to a Network

5.3.2.1. Art-Net Settings

- 01) Install any Art-Net-based software on your PC (Windows or Mac) or use a light controller which supports Art-Net.
- 02) Connect the device's RJ45 connector to the RJ45 connector of the lighting controller/network switch, using a CAT-5/CAT-6 cable.
- 03) Set the IP address of your computer/light controller to **2.x.x.x** or **10.x.x.x**, depending on the Art-Net settings. See **6.6.6. IP Mode** on pages 26 for more information.
- 04) Set the Subnet mask on all devices. See **6.6.7. Netmask** on page 27 for more information.
- 05) Make sure that all fixtures in the network have a **unique IP address**.
- 06) If you want to connect more fixtures, follow the example below.

Note: When creating large setups, it is recommended to use a 16-bit, high speed Ethernet switch to distribute the Art-Net data signal.

Example settings:

If you want to connect multiple devices using Art-Net protocol, proceed as follows:

- 01) Set the universe of the first LED SPI-2 to **000**. See **6.6.3.1 Universe** on page 23.
- 02) Set the DMX starting address of the first LED SPI-2 to **001**.
- 03) If you want to operate the LED SPI-2 in 510-channel DMX mode, you can connect only 1 devices. Due to the channel limit of 512, you cannot connect the second fixture to the same data line, as it would result in limited functionality of this device.
- 04) In order to solve this problem, set the universe of the second LED SPI-2 to **1** and its DMX address to **001**.
- 05) When connecting multiple devices, you can repeat steps 1 to 4 up to 255 times, each time inserting ascending universe numbers (as there are 256 universes available).
- 06) Map all connected devices. The connected LED SPI-2 fixtures are now ready for use.

There are 512 channels in 1 universe. The universe number is made up of the sub and the port numbers (sub:port). Thus, the number of the 1st universe will be 000 (00:00), the number of the 2nd – 001 (00:01), etc. There are 256 universes in 1 net. The last universe in the net will have the number 255 (15:15).

Note: Counting begins at 0.

Art-Net is a protocol that uses TCP/IP to transfer large amount of DMX-512 data over an Ethernet network. Art-Net 4 can support up to 32768 universes. Art-Net™ Designed by and Copyright Artistic Licence Holdings Ltd.

5.3.2.2. Kling-Net Settings

- 01) Install any Kling-Net-based software on your PC (Windows or Mac), for example **50180** – Arkaos LED Master or **50224** – Media Master Express 4.0.
- 02) Make sure that your PC has a **fixed IP Address**. The LED SPI-2 requires no further network setting adjustments.
- 03) Connect the LED SPI-2 with a CAT-5/CAT-6 cable to your computer. Once you have connected the devices, they will automatically be recognized by the software.
- 04) Map the devices, using the “drag-and-drop” method, by placing the fixtures in “on-screen” interface in the right position. Now the system is completely set up.

Note:

When creating large setups, it is recommended to use a 16-bit, high speed Ethernet switch to distribute the Kling-Net data signal.

5.4. How To Make a Data Cable

A standard ETHERNET cable can be used to replace the data cable required to transmit the data.

Please follow the instructions below in order to create an extra network cable.

Take a standard network cable (CAT-5/ 5E /6) and connect it to the RJ45 connector, as shown in Fig. 12. The wires should now be colored as follows:

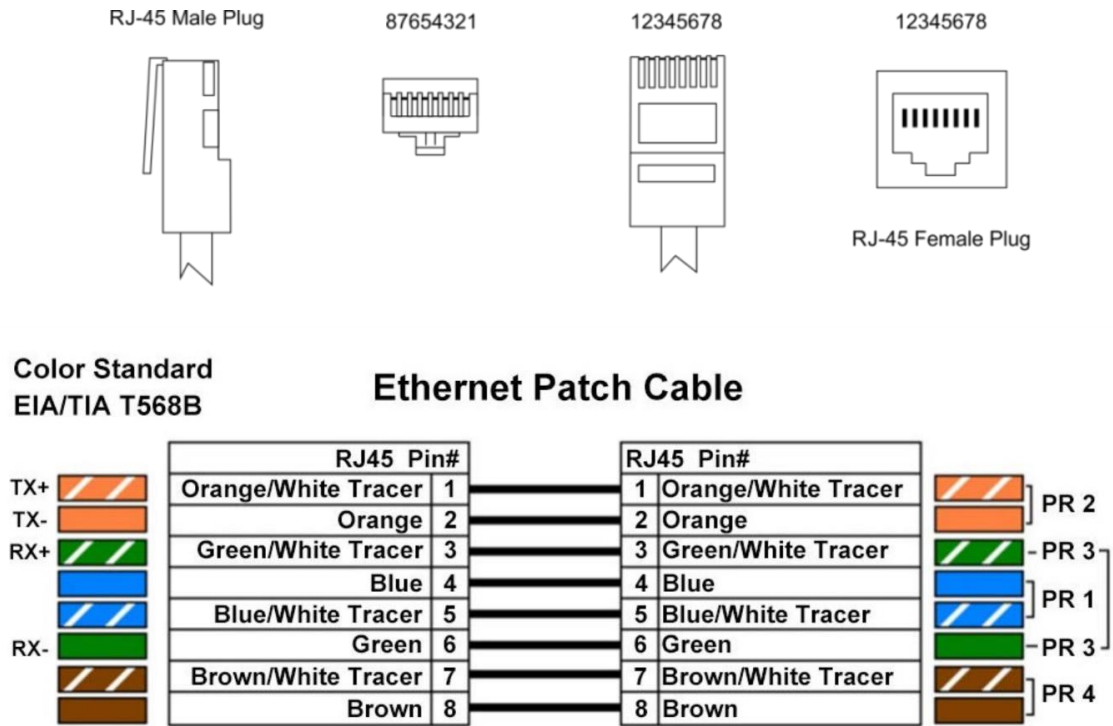

Fig. 12

6. Operation

6.1. Safety Instructions for Operation



Attention

This device must be used only for the purposes it is designed for.

This device is intended for professional use as a T-bar. It is suitable only for indoor installation. This device is not suitable for households and for general lighting.

Any other use, not mentioned under intended use, is regarded as non-intended and incorrect use.



Attention

Power supply

Before connecting the device to the power supply, make sure that the current, voltage and frequency match the input voltage, current and frequency specified on the information label on the device.

6.2. Control Modes

The LED SPI-2 Install supports the following control modes:

- Stand-alone: Manual, Preset Colors, Built-in programs
- DMX-512, sACN, Art-Net 17, 34, 512 channels

For more information about how to connect the devices, refer to **5. Setup** on pages 13–17.

To operate the device manually as a stand-alone device:

- Adjust the colors in Manual menu. See **6.6.4.1. User Color** on page 24 for more information.

To run the preset colors without a DMX controller:

- 01) Select one of the 7 preset colors in Color Preset menu. See **6.6.4.2. Color Preset** on page 24 for more information.

To run the built-in programs without a DMX controller:

- 01) Select one of the 22 built-in programs in Program menu. See **6.6.4.3. Program** on page 25 for more information. Adjust the program speed.

To operate the device with a DMX controller:

- 01) Set the DMX starting address of the device in Address menu. See **5.2.4. DMX Addressing** on page 15 and **6.6.3.1. Output 1 / Output 2** on page 23.
- 02) Select the DMX channel mode. See **6.6.2. Personality** on page 22 for more information. See **6.7. DMX Channels** on pages 30–33 for complete overview of all DMX channels.

6.3. Control Panel

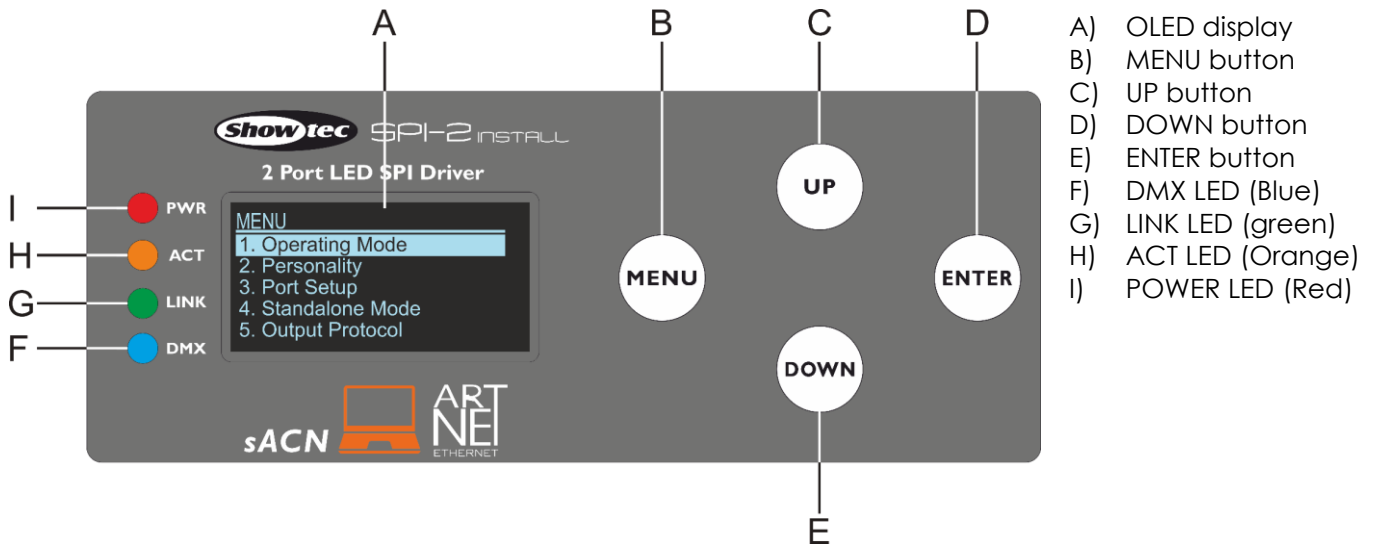

Fig. 13

- Use the **MENU** button to exit the current submenu and to return to the Main Menu.
- Use the **UP/DOWN** buttons to navigate through the menus or to increase/decrease numeric values.
- Use the **ENTER** button to open the desired menu, to confirm your choice or to set the currently selected value.

6.4. Start-up

Upon start-up the display will briefly show software version and the current settings.

Note:

If no button is pressed after 30 seconds of inactivity, the display will dim depending on your setting. See **6.6.8. LCD Backlight** on page 27 for more information. Press any button to power up the LCD display.

6.5. Menu Overview

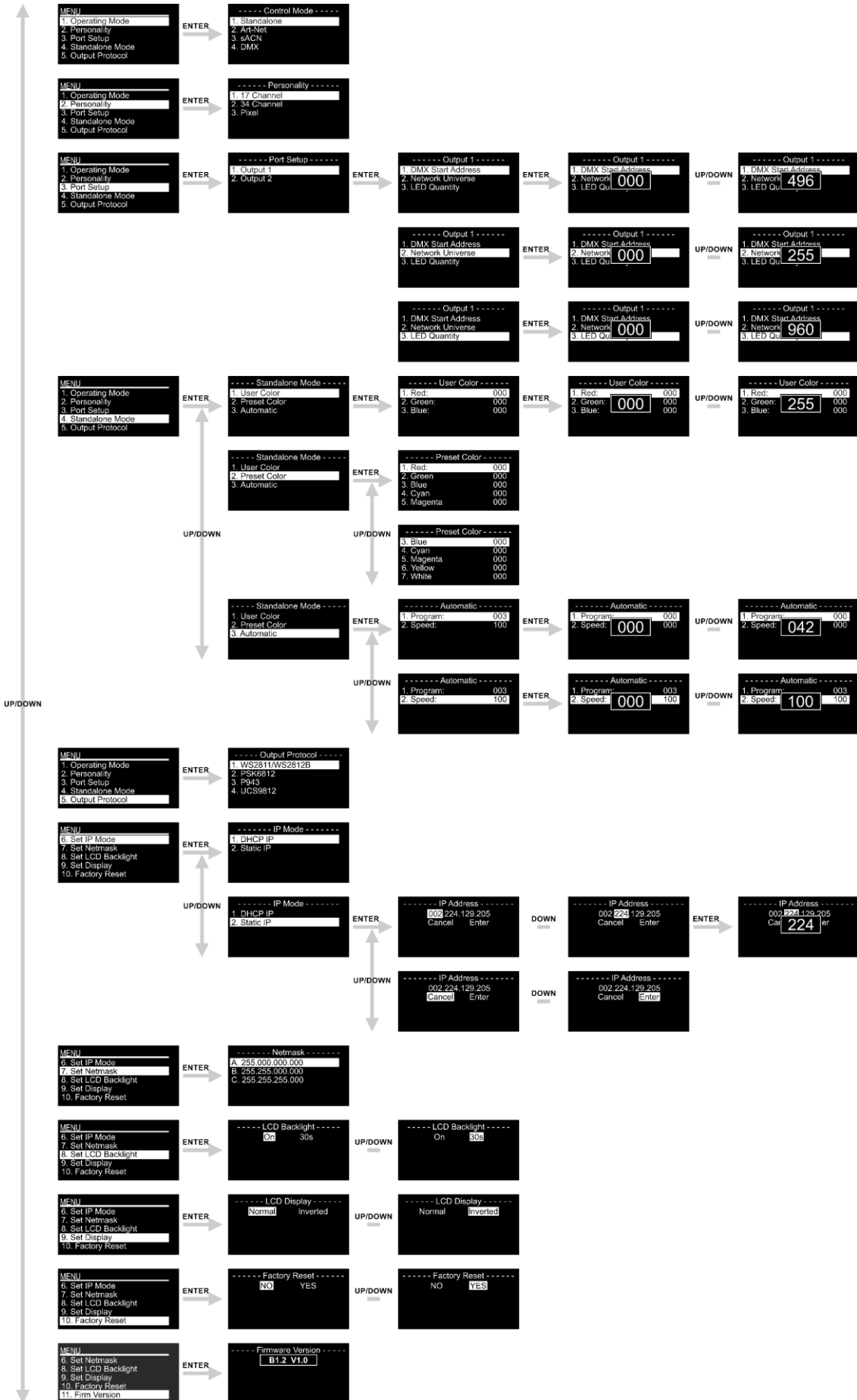

6.6. Main Menu Options

Upon start-up the display will show software version and the current settings.



SPI-2 Install
V1.0

Device Status	
Standalone	
IP:2:224:129:205	
N-A:x	DMX:x

Device Status		
DMX		
D1:001	Pixel	D2:001
N-A:x	DMX:x	

The main menu has the following options:

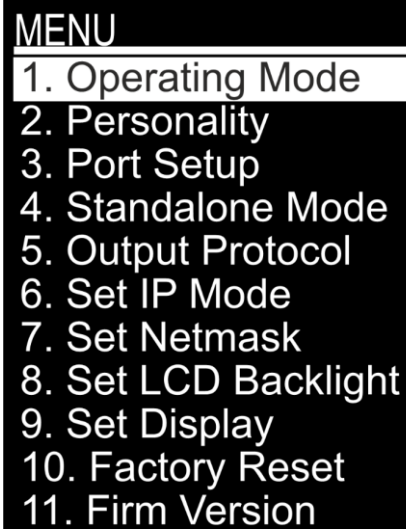

MENU

1. Operating Mode
2. Personality
3. Port Setup
4. Standalone Mode
5. Output Protocol
6. Set IP Mode
7. Set Netmask
8. Set LCD Backlight
9. Set Display
10. Factory Reset
11. Firm Version

- 01) Press the **UP/DOWN** buttons to navigate through the main menu.
- 02) Press the **ENTER** button to open the submenus.

6.6.1. Operating Mode

In this menu you can choose the desired Operating mode.

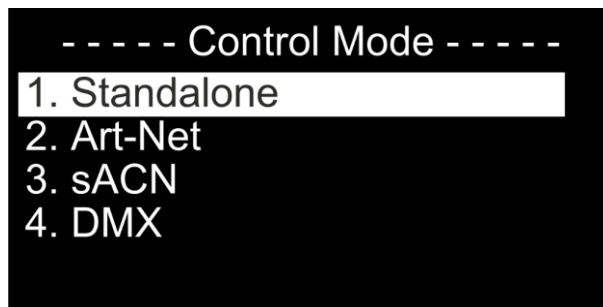

- 01) Press the **UP/DOWN** buttons to navigate through the main menu.
- 02) Press the **ENTER** button to confirm your setting.

6.6.2. Personality

In this menu you can choose the desired DMX mode.

- 01) While in the main menu, press the **UP/DOWN** buttons to choose Personality.
- 02) Press the **ENTER** button to enter the menu. The display will show:

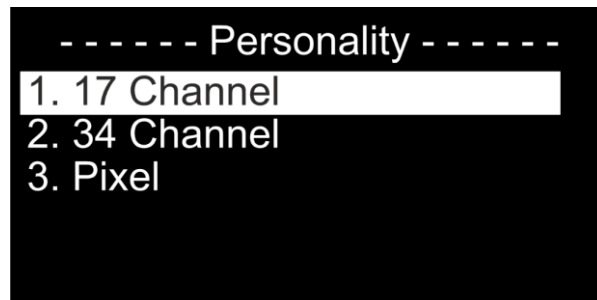

- 03) Press the **UP/DOWN** buttons to select one of the 3 personality modes:
 - 17 Channel
 - 34 Channel
 - Pixel
- 04) Press the **ENTER** button to confirm your setting.

6.6.3. Port Setup

In this menu you can choose the desired Output Port.

- 01) While in the main menu, press the **UP/DOWN** buttons to choose Port Setup.
- 02) Press the **ENTER** button to enter the menu. The display will show:

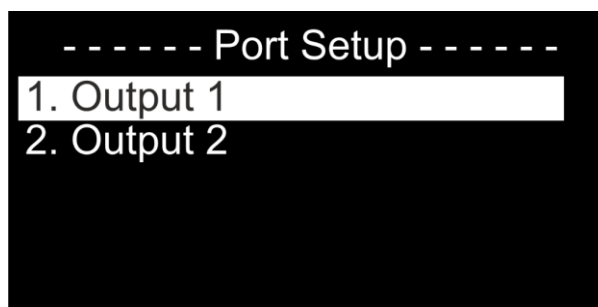

- 03) Press the **UP/DOWN** buttons to select one of the 2 submenus:
 - Output 1
 - Output 2
- 04) Press the **ENTER** button to confirm your setting.

6.6.3.1. Output 1 / Output 2

In this menu you can choose the settings for the desired Output Port.

01) If you have chosen Output 1, the display will show:

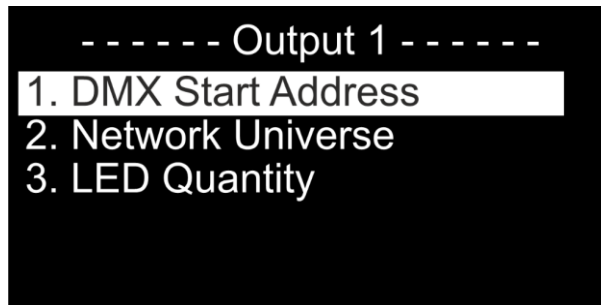

02) Press the **UP/DOWN** buttons to select one of the 3 submenus:

- DMX Start Address
- Network Universe
- LED Quantity

03) Press the **ENTER** button to enter the desired menu.

04) If you have chosen DMX Start Address, press the **UP/DOWN** buttons to set the desired DMX Start Address. The adjustment range is 001–512. Press the **ENTER** button to confirm your setting.

05) If you have chosen Network Universe, press the **UP/DOWN** buttons to set the Network Universe. The adjustment range is 000–255. Press the **ENTER** button to confirm your setting.

06) If you have chosen LED Quantity, press the **UP/DOWN** buttons to set the LED Quantity. The adjustment range is 000–960. Press the **ENTER** button to confirm your setting.

Note:

- A 12V 5m LED strip is 100 pixels and uses 300 channels
- A 24V 5m LED strip is 50 pixels and uses 150 channels

Without looking at the length of your pixel strip

1 Pixel @ 24V = 6 LEDS = 10 cm

1 Pixel @ 12V = 3 LEDS = ± 5 cm

1 Pixel @ 5V = 1 LED = ± 1,7 cm

6.6.4. Stand-alone Mode

In this menu you can choose the desired Stand-alone Mode.

01) While in the main menu, press the **UP/DOWN** buttons to choose Port Setup.

02) Press the **ENTER** button to enter the menu. The display will show:

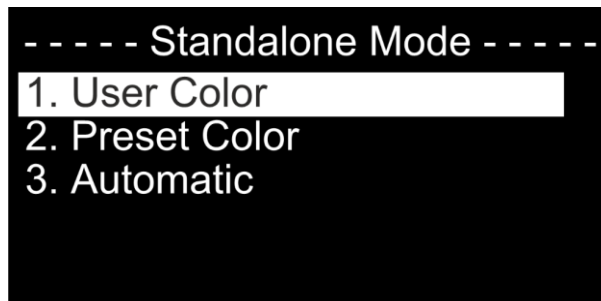

03) Press the **UP/DOWN** buttons to select one of the 3 submenus:

- User Color
- Preset Color
- Automatic

04) Press the **ENTER** button to confirm your setting.

6.6.4.1. User Color

In this menu you can set the desired color.

01) If you have chosen User Color, the display will show:

----- User Color -----	
1. Red:	000
2. Green:	000
3. Blue:	000

02) Press the **UP/DOWN** buttons to select one of the 3 manually adjustable colors:

- Red
- Green
- Blue

03) Press the **ENTER** button to enter the desired color menu.

04) Press the **UP/DOWN** buttons to set the LED brightness. The adjustment range for each color is 0–255, from dark to brightest. Press the **ENTER** button to confirm your setting.

05) You can combine Red, Green and Blue to create an infinite range of colors (0–255).

6.6.4.2. Preset Color

In this menu you can set the desired color.

01) If you have chosen Preset Color, the display will show:

----- Preset Color -----	
1. Red:	000
2. Green	000
3. Blue	000
4. Cyan	000
5. Magenta	000
6. Yellow	000
7. White	000

02) Press the **UP/DOWN** buttons to select one of the 7 preset colors:

- Red
- Green
- Blue
- Cyan
- Magenta
- Yellow
- White

03) Press the **ENTER** button to confirm your setting.

6.6.4.3. Automatic Programs

In this menu you can set the desired auto program.

01) If you have chosen Automatic, the display will show:

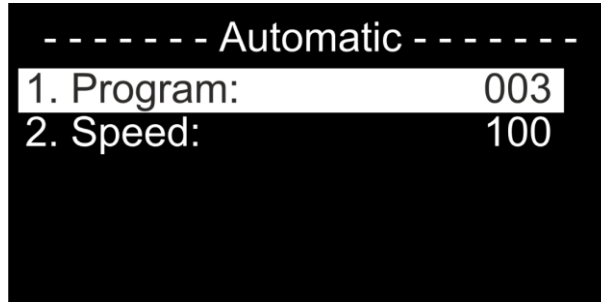

02) Press the **UP/DOWN** buttons to select one of the 2 submenus:

- Program
- Speed

03) Press the **ENTER** button to enter the desired menu.

04) If you have chosen PROGRAM, press the **UP/DOWN** buttons to choose one of the 42 built-in programs. Press the **ENTER** button to confirm your setting.

05) If you have chosen SPEED, press the **UP/DOWN** buttons to set the built-in program's speed. The adjustment range is 1–100, from slow to fast. Press the **ENTER** button to confirm your setting.

6.6.5. Output Protocol

In this menu you can choose the desired Output Protocol.

01) While in the main menu, press the **UP/DOWN** buttons to choose Port Setup.

02) Press the **ENTER** button to enter the menu. The display will show:

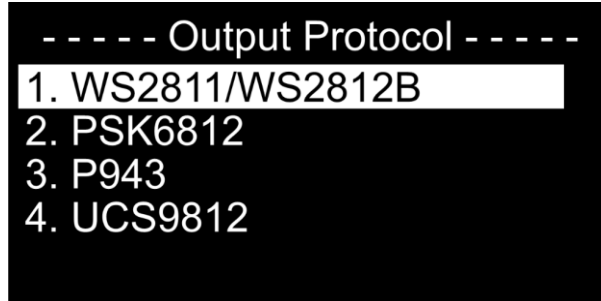

03) Press the **UP/DOWN** buttons to select one of the 4 Output Protocols:

- WS2811/WS2812B
- PSK6812
- P943
- UCS9812

04) Press the **ENTER** button to confirm your desired protocol.

6.6.6. IP Mode

In this menu you can choose the desired IP Mode.

- 01) While in the main menu, press the **UP/DOWN** buttons to choose Set IP Mode.
- 02) Press the **ENTER** button to enter the menu. The display will show:

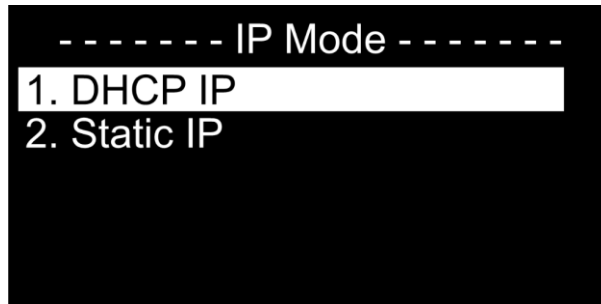

- 03) Press the **UP/DOWN** buttons to select one of the 2 IP Modes:
 - DHCP IP
 - Static IP
- 04) Press the **ENTER** button to confirm your desired protocol.

6.6.6.1. DHCP IP

In this menu you can set the DHCP IP.

This means the LED SPI-2 will automatically search for the right IP configuration, when your controller has also been set to DHCP.

6.6.6.2. Static IP

In this menu you can set the Static IP.

- 01) If you have chosen Static IP, the display will show:



- 02) Press the **ENTER** button to enter the menu. The display will show:



- 03) Press the **UP/DOWN** buttons to adjust the IP Address.
- 04) Press the **ENTER** button to confirm your setting.
- 05) Press the **DOWN** button to switch from the first to the 2nd, 3rd and 4th part.
- 06) The adjustment range for each part is 0–255. Press the **ENTER** button to confirm your setting.

6.6.7. Netmask

In this menu you can choose the desired Netmask.

- 01) While in the main menu, press the **UP/DOWN** buttons to choose Set Netmask.
- 02) Press the **ENTER** button to enter the menu. The display will show:

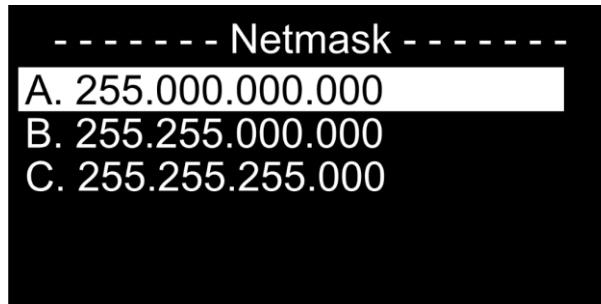

- 03) Press the **UP/DOWN** buttons to select one of the 3 Netmasks:
 - 255.000.000.000
 - 255.255.000.000
 - 255.255.255.000
- 04) Press the **ENTER** button to confirm your desired Netmask.

6.6.8. LCD Backlight

In this menu you can choose the desired LCD Backlight.

- 01) While in the main menu, press the **UP/DOWN** buttons to choose Set LCD Backlight.
- 02) Press the **ENTER** button to enter the menu. The display will show:



- 03) Press the **UP/DOWN** buttons to select one of the 2 options:
 - On
 - 30 seconds
- 04) If you choose the option "**ON**", the display will remain continuously ON.
- 05) If you choose the option "**30s**", the display will dim after 30 seconds.
- 06) Press the **ENTER** button to confirm your setting.

6.6.9. Display Invert

In this menu you can choose to invert the LCD Display.

- 01) While in the main menu, press the **UP/DOWN** buttons to choose Set Display.
- 02) Press the **ENTER** button to enter the menu. The display will show:

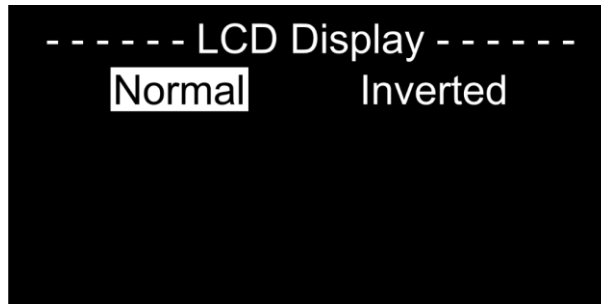

- 03) Press the **UP/DOWN** buttons to select one of the 2 options:
 - Normal
 - Inverted
- 04) If you choose the option "**Normal**", the display will remain continuously ON.
- 05) If you choose the option "**Inverted**", the display will flip 180°.
- 06) Press the **ENTER** button to confirm your setting.

6.6.10. Factory Reset

In this menu you can choose to reset your device.

- 01) While in the main menu, press the **UP/DOWN** buttons to choose Factory Reset.
- 02) Press the **ENTER** button to enter the menu. The display will show:

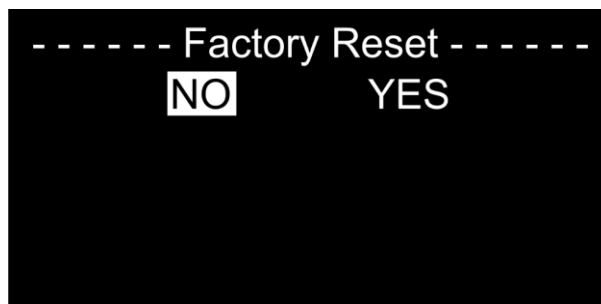

- 03) Press the **UP/DOWN** buttons to select one of the 2 options:
 - No
 - Yes
- 04) If you choose the option "**No**", the device will keep its current settings.
- 05) If you choose the option "**Yes**", the device will reset back to its factory settings.
- 06) Press the **ENTER** button to confirm your setting.

6.6.11. Firmware version

In this menu you can view the current firmware version of your device.

- 01) While in the main menu, press the **UP/DOWN** buttons to choose Firm Version.
- 02) Press the **ENTER** button to enter the menu. The display will show:



6.7. DMX Channels

6.7.1. 17 Channels

17 CH	Function	Value	Setting
1	Master Dimmer	000–255	From low to high intensity (0–100 %)
2	Foreground Color Red	000–255	From low to high intensity (0–100 %)
3	Foreground Color Green	000–255	From low to high intensity (0–100 %)
4	Foreground Color Blue	000–255	From low to high intensity (0–100 %)
5	Foreground Strobe	000–010	Close
		011–050	From low to high frequency (0–20 Hz)
		051–090	Random Strobe, from low to high frequency (0–20 Hz)
		091–140	Synchr. strobe, from low to high frequency (0–20 Hz)
		141–255	No Function
6	Background Color Red	000–255	From low to high intensity (0–100 %)
7	Background Color Green	000–255	From low to high intensity (0–100 %)
8	Background Color Blue	000–255	From low to high intensity (0–100 %)
9	Background Strobe	000–010	Close
		011–050	From low to high frequency (0–20 Hz)
		051–090	Random Strobe, from low to high frequency (0–20 Hz)
		091–140	Synchr. strobe, from low to high frequency (0–20 Hz)
		141–255	No Function
10	Foreground Program	000–020	Auto 0
		021–040	Auto 1
		041–060	Auto 2
		061–065	Auto 3
		066–080	Multi-color Program(doesn't respond to RGB channels)
		081–100	Color Fade 1 (doesn't respond to RGB channels)
		101–120	Color Fade 2(doesn't respond to RGB channels)
		121–140	Color Fade 3(doesn't respond to RGB channels)
		141–255	No Function
11	Foreground Prog. Speed	000–255	From low to high speed
12	Foreground Offset Len	000–255	Foreground Offset Len
13	Background Program	000–020	Auto 0
		021–040	Auto 1
		041–060	Auto 2
		061–065	Auto 3
		066–100	Color Fade 1 (doesn't respond to RGB channels)
14	Background Prog. Speed	000–255	From low to high speed
15	Background Offset Len	000–255	Background Offset Len
16	No function	000–255	0-100%
17	Foreground Program	000–020	No Function
		021–030	Test 1(White)
		031–040	Test 2(Color Fade)
		041–050	Test 3(Rainbow Scroll)
		051–060	Test 4(Red)
		061–070	Test 5(Green)
		071–080	Test 6(Blue)
		081–255	No Function

Note: Make sure that the Master Dimmer channel is open in order to see the light output.

6.7.2. 34 Channels

Output Port 1 CH 1 - CH17

Output Port 2: CH18 - CH34

34 CH	Function	Value	Setting
1	Master Dimmer Port 1	000–255	From low to high intensity (0–100 %)
2	Foreground Color Red	000–255	From low to high intensity (0–100 %)
3	Foreground Color Green	000–255	From low to high intensity (0–100 %)
4	Foreground Color Blue	000–255	From low to high intensity (0–100 %)
5	Foreground Strobe	000–010	Close
		011–050	From low to high frequency (0–20 Hz)
		051–090	Random Strobe, from low to high frequency (0–20 Hz)
		091–140	Synchr. strobe, from low to high frequency (0–20 Hz)
		141–255	No Function
6	Background Color Red	000–255	From low to high intensity (0–100 %)
7	Background Color Green	000–255	From low to high intensity (0–100 %)
8	Background Color Blue	000–255	From low to high intensity (0–100 %)
9	Background Strobe	000–010	Close
		011–050	From low to high frequency (0–20 Hz)
		051–090	Random Strobe, from low to high frequency (0–20 Hz)
		091–140	Synchr. strobe, from low to high frequency (0–20 Hz)
		141–255	No Function
10	Foreground Program	000–020	Auto 0
		021–040	Auto 1
		041–060	Auto 2
		061–065	Auto 3
		066–080	Multi-color Program (doesn't respond to RGB channels)
		081–100	Color Fade 1 (doesn't respond to RGB channels)
		101–120	Color Fade 2 (doesn't respond to RGB channels)
		121–140	Color Fade 3 (doesn't respond to RGB channels)
141–255	No Function		
11	Foreground Prog. Speed	000–255	From low to high speed
12	Foreground Offset Len	000–255	Foreground Offset Len
13	Background Program	000–020	Auto 0
		021–040	Auto 1
		041–060	Auto 2
		061–065	Auto 3
		066–100	Color Fade 1 (doesn't respond to RGB channels)
14	Background Prog. Speed	000–255	From low to high speed
15	Background Offset Len	000–255	Background Offset Len
16	No function	000–255	0-100%
17	Foreground Program	000–020	No Function
		021–030	Test 1 (White)
		031–040	Test 2 (Color Fade)
		041–050	Test 3 (Rainbow Scroll)
		051–060	Test 4 (Red)
		061–070	Test 5 (Green)
		071–080	Test 6 (Blue)
081–255	No Function		

Output Port 2

18	Master Dimmer Port 2	000–255	From low to high intensity (0–100 %)
19	Foreground Color Red	000–255	From low to high intensity (0–100 %)
20	Foreground Color Green	000–255	From low to high intensity (0–100 %)
21	Foreground Color Blue	000–255	From low to high intensity (0–100 %)
22	Foreground Strobe	000–010	Close
		011–050	From low to high frequency (0–20 Hz)
		051–090	Random Strobe, from low to high frequency (0–20 Hz)
		091–140	Synchr. strobe, from low to high frequency (0–20 Hz)
		141–255	No Function
23	Background Color Red	000–255	From low to high intensity (0–100 %)
24	Background Color Green	000–255	From low to high intensity (0–100 %)
25	Background Color Blue	000–255	From low to high intensity (0–100 %)
26	Background Strobe	000–010	Close
		011–050	From low to high frequency (0–20 Hz)
		051–090	Random Strobe, from low to high frequency (0–20 Hz)
		091–140	Synchr. strobe, from low to high frequency (0–20 Hz)
		141–255	No Function
27	Foreground Program	000–020	Auto 0
		021–040	Auto 1
		041–060	Auto 2
		061–065	Auto 3
		066–080	Multi-color Program(doesn't respond to RGB channels)
		081–100	Color Fade 1(doesn't respond to RGB channels)
		101–120	Color Fade 2(doesn't respond to RGB channels)
		121–140	Color Fade 3(doesn't respond to RGB channels)
141–255	No Function		
28	Foreground Prog. Speed	000–255	From low to high speed
29	Foreground Offset Len	000–255	Foreground Offset Len
30	Background Program	000–020	Auto 0
		021–040	Auto 1
		041–060	Auto 2
		061–065	Auto 3
		066–100	Color Fade 1(doesn't respond to RGB channels)
31	Background Prog. Speed	000–255	From low to high speed
32	Background Offset Len	000–255	Background Offset Len
33	No function	000–255	0-100%
34	Foreground Program	000–020	No Function
		021–030	Test 1(White)
		031–040	Test 2(Color Fade)
		041–050	Test 3(Rainbow Scroll)
		051–060	Test 4(Red)
		061–070	Test 5(Green)
		071–080	Test 6(Blue)
081–255	No Function		

Note: Make sure that the Master Dimmer channel is open in order to see the light output.

6.7.3. 510 Channels

510 CH	Function	Value	Setting
1	Pixel 1 Red	000–255	From low to high intensity (0–100 %)
2	Pixel 1 Green	000–255	From low to high intensity (0–100 %)
3	Pixel 1 Blue	000–255	From low to high intensity (0–100 %)
4	Pixel 2 Red	000–255	From low to high intensity (0–100 %)
5	Pixel 2 Green	000–255	From low to high intensity (0–100 %)
6	Pixel 2 Blue	000–255	From low to high intensity (0–100 %)
7	Pixel 3 Red	000–255	From low to high intensity (0–100 %)
8	Pixel 3 Green	000–255	From low to high intensity (0–100 %)
9	Pixel 3 Blue	000–255	From low to high intensity (0–100 %)

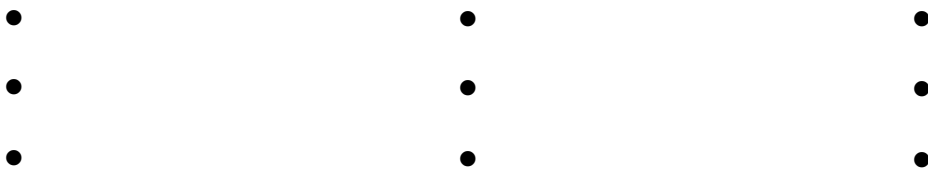

505	Pixel 169 Red	000–255	From low to high intensity (0–100 %)
506	Pixel 169 Green	000–255	From low to high intensity (0–100 %)
507	Pixel 169 Blue	000–255	From low to high intensity (0–100 %)
508	Pixel 170 Red	000–255	From low to high intensity (0–100 %)
509	Pixel 170 Green	000–255	From low to high intensity (0–100 %)
510	Pixel 170 Blue	000–255	From low to high intensity (0–100 %)

6.8. UID number

The unique identification number of the device (UID) for the LED SPI-2 is 29B4.

7. Troubleshooting

This troubleshooting guide contains solutions to problems which can be carried out by an ordinary person. The device does not contain user-serviceable parts.

Unauthorized modifications to the device will render the warranty void. Such modifications may result in injuries and material damage.

Refer servicing to instructed or skilled persons. Contact your Highlite International dealer in case the solution is not described in the table.

Problem	Probable cause(s)	Solution
The device does not function at all	No power to the device	<ul style="list-style-type: none"> Check if power is switched on and cables are plugged in
The device responds erratically	The factory settings of the device are changed	<ul style="list-style-type: none"> Reset the device's parameters to the default factory settings. See 6.6.10. Factory on page 28
The device does not respond to DMX control	The controller is not connected	<ul style="list-style-type: none"> Connect the controller
	The signal is reversed. The 3-pin/5-pin DMX OUT of the controller does not match the DMX IN of the device	<ul style="list-style-type: none"> Install a phase-reversing cable between the controller and the device
The device responds erratically to DMX control	The controller is defective	<ul style="list-style-type: none"> Try using another controller
	Bad data link connection	<ul style="list-style-type: none"> Examine connections and cables. Correct poor connections. Repair or replace damaged cables
	The data link is not terminated with a 120 Ω termination plug	<ul style="list-style-type: none"> Insert a termination plug in the DMX OUT connector of the last device on the link
	Incorrect addressing	<ul style="list-style-type: none"> Check address settings and correct, if necessary
	In case of a setup with multiple devices, one of the devices is defective and disturbs data transmission on the link	<ul style="list-style-type: none"> To find out the defective device, bypass one device at a time until normal operation is restored
No light or LEDs cut out intermittently	LEDs are damaged	<ul style="list-style-type: none"> Disconnect the device and contact your Highlite International dealer
	The power supply settings do not match local AC voltage and frequency	<ul style="list-style-type: none"> Disconnect the device. Check the settings and correct, if necessary

8. Maintenance

8.1. Safety Instructions for Maintenance



DANGER
Electric shock caused by dangerous voltage inside

Disconnect power supply before servicing or cleaning.



WARNING
Risk of burns due to hot surface

Allow the device to cool down for at least 15 minutes before servicing or cleaning.

8.2. Preventive Maintenance



Attention
Before each use, examine the device visually for any defects.

Make sure that:

- All screws used for installing the device or parts of the device are tightly fastened and are not corroded.
- The safety devices are not damaged.
- There are no deformations on housings, fixations and installation points.
- The lens is not cracked or damaged.
- The power cables are not damaged and do not show any material fatigue.

8.2.1. Basic Cleaning Instructions

The external lens of the device must be cleaned periodically in order to optimize the light output. The cleaning schedule depends on the conditions at the site where the device is installed. When smoke or fog machines are used at the site, the device will need more frequent cleaning. On the other hand, if the device is installed in well-ventilated area, it will need less frequent cleaning. To establish a cleaning schedule, examine the device at regular intervals during the first 100 hours of operation.

To clean the device, follow the steps below:

- 01) Disconnect the device from the electrical power supply.
- 02) Allow the device to cool down for at least 15 minutes.
- 03) Remove the dust collected on the external surface with dry compressed air and a soft brush.
- 04) Clean the lens with a damp cloth. Use a mild detergent solution.
- 05) Dry the lens carefully with a lint-free cloth.
- 06) Clean the DMX and other connections with a damp cloth.



Attention

- Do not immerse the device in liquid.
- Do not use alcohol or solvents.
- Make sure that the connections are fully dry before connecting the device to the power supply and to other devices.

8.3. Corrective Maintenance

The device does not contain user-serviceable parts. Do not open the device and do not modify the device.

Refer repairs and servicing to instructed or skilled persons. Contact your Highlite International dealer for more information.

9. Deinstallation, Transportation and Storage

9.1. Instructions for Deinstallation

**WARNING**

Incorrect deinstallation can cause serious injuries and damage of property.

- Let the device cool down before dismounting.
- Disconnect power supply before deinstallation.
- Always observe the national and site-specific regulations during deinstallation and derigging of the device.
- Wear personal protective equipment in compliance with the national and site-specific regulations.

9.2. Instructions for Transportation

- Use the original packaging to transport the device, if possible.
- Always observe the handling instructions printed on the outer carton box, for example: "Handle with care", "This side up", "Fragile".

9.3. Storage

- Clean the device before storing. Follow the cleaning instructions in chapter **8.2.1. Basic Cleaning Instructions** on page 36.
- Store the device in the original packaging, if possible.

10. Disposal

Correct disposal of this product

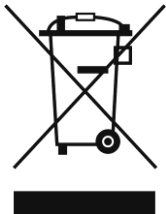

Waste Electrical and Electronic Equipment

This symbol on the product, its packaging or documents indicates that the product shall not be treated as household waste. Dispose of this product by handing it to the respective collection point for recycling of electrical and electronic equipment. This is to avoid environmental damage or personal injury due to uncontrolled waste disposal. For more detailed information about recycling of this product contact the local authorities or the authorized dealer.

11. Approval



Check the respective product page on the website of Highlite International (www.highlite.com) for an available declaration of conformity.



©2021 Showtec