

Polyend Step Essentials

A Collection of Essential References
for The Polyend Step

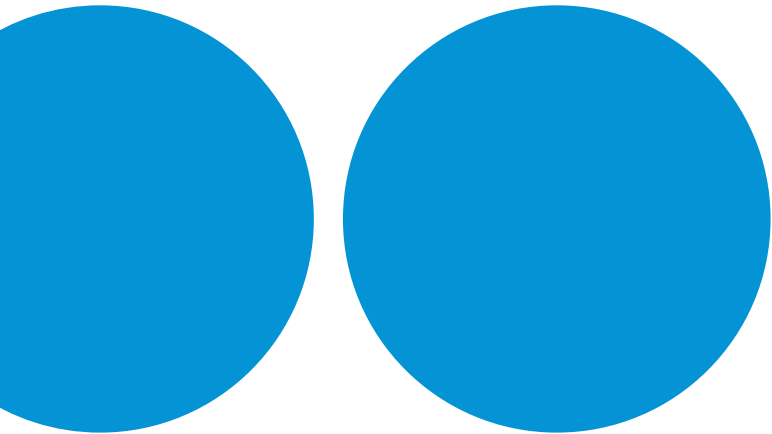

Overview

The Step is a 4 track, sample-based drum machine and sequencer that integrates well with studio and live setups. Step fits well with any electronic desktop synth setup and is an accompaniment or additional instrument for modern live musicians, guitarists, or keyboard players. Step is sample-based and operates with 4 programmable audio tracks, each hosting its own sample based drum kit and effects plus a 16-step pattern sequencer. Samples are 16 bit mono. Multiple patterns can be handled as part of a song with a simple pattern control and playback using onboard foot switches. The control of effects is also handled with a footswitch. Step also boasts unique features, like the ability to load beats

and kits covering various genres and extending beyond classic electronic styles. In Step, think of beats as presets that store patterns based on specific genre styles. A master effects section helps to glue the output together and finalize the production, as well as adding classic end-of-line effects such as delay, reverb, and saturation. Step is MIDI compatible using the USB or mini jack connection with the ability to change patterns via CC input messaging and to change songs using PC messages. Up to 1,000 songs can be created and edited in Step, and the auto-save function will ensure that your progress is saved as part of the workflow. As a final bonus, patterns created in Polyend Play can also be used in Step.

Step Essentials

Hardware Overview

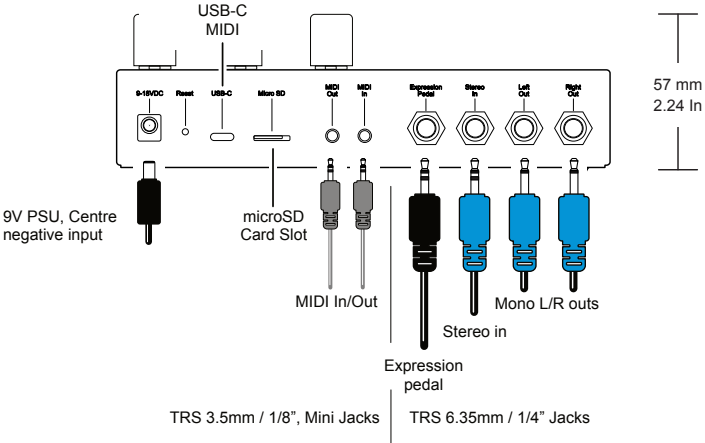

The recessed reset button will help to recover a device if issues exist. Press during start up to load a previous OS from the microSD Card. It is useful to keep previous OS files in the firmware folder.

Power Supply is not included.

Use a standard pedal model, 9-18V DC, 560mA, centre negative (also accepts centre positive).

Weight
930 Grams

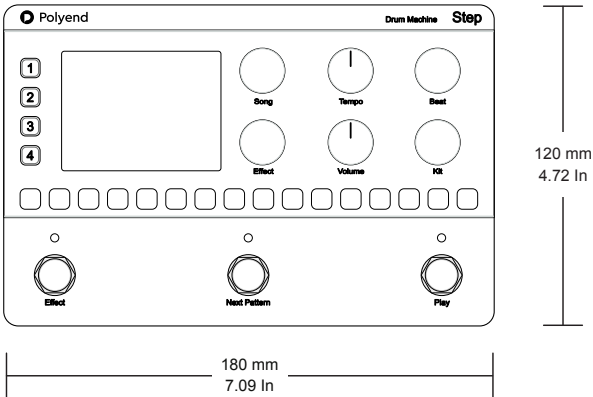

Control Overview

The 2 blue control knobs with the white position indicator are rotary types. The other 4 blue knobs are push/turn knobs. Press to choose a mode, open a menu window, or select an option. Turn to navigate through the options and selections. Knobs and encoders are described with parenthesis e.g. (Volume) in the instruction text. Foot switches are described with curly brackets, {Play} and, pad step and track buttons as [Pad] or [Track 1].

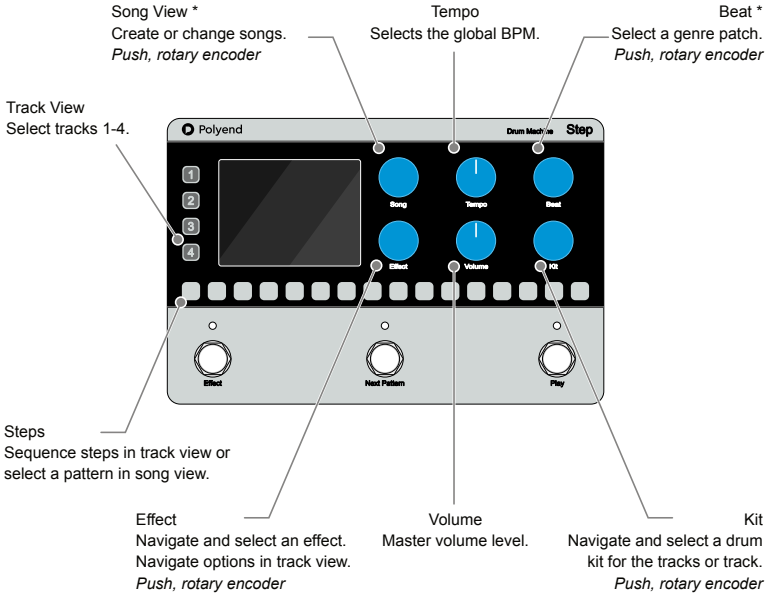

* *Unavailable in track view*

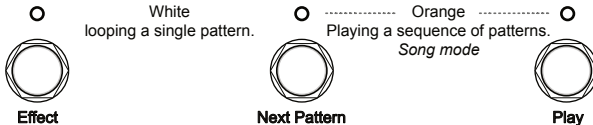

Playing: Activates the selected effect. Stopped: Tap tempo input.

Tap to cue and play the next available pattern. Press & hold to select the next song.

Tap to Start/Stop playing the current pattern. Press & hold to play in song mode, i.e. play all patterns.

Step Essentials

Summary of Definitions

Step: This is the name of our 4-track drum machine pedal with sequencing capabilities. A step is also a programming point in the sequencer, with a total of 16 steps used to create a pattern of beats.

Track: A track consists of 16 steps that can be sequenced into a pattern to create a rhythm using the sounds managed in a kit. Each track controls the sounds like kick, snare, hat, etc. Each track is managed and controlled individually when in track view.

Kit: A kit is a collection of sample sounds applied to the tracks, one sample per track. Kits are loaded to all 4 tracks when in song mode and only to the selected track when in track view. The kit browser organizes the kits listed under types, which helps you organize and choose the style of kit you need for your song. A kit is selected and loaded immediately when navigating in the kit browser list.

Pattern: The sequence created for all four tracks, each with a maximum of 16 Steps, is called a pattern. 16 Patterns are available, each selected with the step pads when in song mode i.e. no track selected. In track view, the step pads are used to create steps of beats in the pattern. Increment through available patterns with the 'Next Pattern' footswitch.

Beat: A beat is a predefined collection of patterns sequenced together in a genre style. When selected, these beats are applied to the sequence in each track and help to create an instant rhythm. Beats are organized in the browser by 'genre' for ease of selection. A beat is selected and loaded at the start of the current pattern while navigating to a beat in the browser list.

Effect: An effect is a utility that shapes, adds movement, and affects the sound character. For example, a reverb emulates a room space and the ambiance it adds. Punch-In performance effects can be switched on or off using the footswitch. A library of effects is available. In addition, several master effects can be assigned to the master outputs.

Song: A song consists of all the parameters, such as tempo and volume, as well as the kit, beat, effect configurations, and pattern settings. It helps store and recall the entire project. Song view is the default when starting up Step and when all tracks are deselected.

Tempo: The clock controls the step pedal and sets the speed of the sequencer in beats per minute (BPM) between a range of 30 and 280. An external MIDI clock can also be used to control the tempo of step.

MIDI: MIDI, Musical Instrument Digital Interface, is a protocol used to communicate between audio devices. The Step pedal accepts MIDI In and sends MIDI out either using the TRS or USB connectors. MIDI control can be used to adjust parameters (CC), play patterns (Note), and song changes (PC).

Control Details

Control	Function	Description
Track View	Buttons 1-4	Press 1-4 to select a track. Track view is on or off for the specifically selected track. Only one track can be selected at a time. The pad flashes when a step for the track is playing. Step pads are used for sequencing pattern steps when in track view.
Steps	Pad buttons	In track view, the drum pattern is sequenced using the 16 pads to create steps. When in song view, i.e. when tracks are deselected, use the step pads to select and manage each of the 16 patterns.
Effect	Foot Switch	While playing, hold to temporarily turn the assigned effect on or off or tap to latch the effect on or off. You can also control the effect behavior during pattern changes in conjunction with the pattern change footswitch. When stopped, this footswitch acts as a tap tempo input.
Next Pattern	Foot Switch	Patterns will usually loop playback. Press this footswitch to increment to select the following available pattern to play. The footswitch LED will flash if the current pattern still plays, pending a change at the end, and then move on to the following pattern. Press and hold to change songs.
Play	Foot Switch	Tap to play the current pattern. The step pads are lit to reflect the playhead position. If a track is selected, the step pads represent the track color. Press & hold to start/stop playback and advance all patterns automatically.
Song	Push Encoder	In song view, press or turn to open the song browser menu. Open or create up to 1000 songs. Press & hold in any view to open the global options menu which includes MIDI, Settings, Master FX, Firmware etc.
Effect	Push Encoder	In song view, press or turn to select the effect list. Press to switch browsing between the category and effect preset. Turn to navigate and press to select. Activate and apply the effects using the 'Effect' footswitch.
Beat	Push Encoder	In song view, press to select the beat list presets. Press to switch browsing between the genre and preset lists. The preset list is the complete list of all genres. Turn to navigate and select in real-time. Beats cannot be selected in track view.
Kit	Push Encoder	Press to open the kit list presets. Press to switch browsing between the type and preset lists. The preset list is the complete list of all types. Turn to navigate and select in real-time. In song view, all tracks will be changed using kit. In track view, kit will change only the selected track.
Tempo	Knob	Turn to adjust the tempo beats per minute (BPM). The range is 30-280 BPM. Changes are applied instantly. Tap tempo is also available using the 'Effect' footswitch when play is stopped. If connected and active, an external MIDI clock will override the internal tempo.
Volume	Knob	Turn to adjust the master volume level between 0 and 100. The display will indicate any changes, which will be applied in real time.

Display screen & control conventions

The display will follow a similar convention when using all Step controls. However there are two main modes of operation to consider. Song view is the default operating mode for generic control for all tracks and settings. Track view enables each of the 4 tracks to be edited individually and step patterns created. Track view is selected by tapping track [1] - [4] button.

The push encoders navigate menus and options while the rotary knobs for volume and tempo operate over a finite range, e.g., Volume 0-100. While navigating, some option menus will 'time out' and revert to the main view after a few seconds of inactivity.

Control knob: Tempo & Volume

Currently active song

Parameter selected

Parameter value

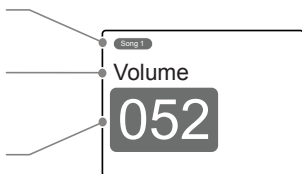

Turn to select and adjust the parameter in real time.

Push encoder: Beat, Kit, Effect and Song

Song # / Pattern # / Beat.

Currently selected option.

Selected category and the associated option.

Category list of options.
For example, Type or Genre.

Option list for categories. All options
for all categories can be navigated.

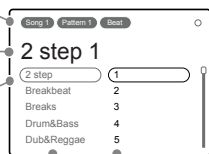

Push to select.



Turn to select and navigate the menu and options in real time. microSD activity shown top right.

The main settings menu can also be navigated and edited using the 'Song' push encoder. Press & hold 'Song' to open the main menu. Turn to navigate, push to select a sub-menu or option. Selecting 'Back' in the sub-menu moves backs up the hierarchy.

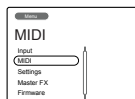

Quick Start with a Basic Pattern

A 16-step pattern can be created for each of the 4 tracks. This is the first step in creating a basic foundation for a longer sequence or a song.

1. As a starting point, turn (Tempo) and set it to 110 BPM. This can be changed later.
2. It's good practice to start with a lower volume, say 40, and then later turn (Volume) up to adjust when the sound is playing. Adjust to a desired level.
3. In song view, select and load a beat. Setting a beat cannot be performed in track view. Deselect the track to enter song view. Maybe choose the '2 step' genre, then select beat '1'. Press (Beat) knob to switch between the genre and the beat number lists. Turn (Beat) to scroll the lists and choose the beat number '1'. Note that scrolling all of the beat numbers will automatically change genre, as this is a complete beat list. The beat will change instantly once selected.

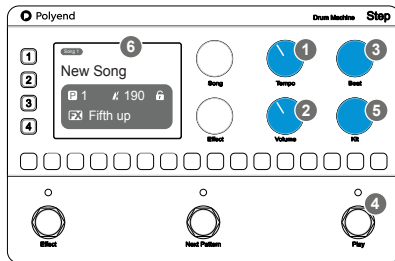

4. Tap {Play} footswitch to play the pattern. The default kit will be played to the beat selected. The play LED will be lit white, and any triggered track buttons will flash in their respective colors. Press again to stop. In song mode, all patterns play in sequence. Press and hold {Play} to playback in song mode. LEDs are orange in song mode.
5. Select and load a global kit to all 4 tracks. Ensure Step is not in track view, i.e. no tracks selected. Press the (Kit) knob to choose between the kit types and kit numbers. Turning the knob will highlight, select and instantly load the kit by number. Note that scrolling the kit numbers will automatically change type as this is a complete kit list. As the pattern is now playing, the kit selected will be used with the 4 tracks in the beat pattern. Try selecting kit 'Classic' and '1' as an example. If an individual track is selected while browsing, then only the kit for the individual track selected is replaced.
6. When editing is completed in song view, the displayed page will automatically time out and revert to displaying the tempo, FX, pattern and lock state.

Step Essentials

Anatomy of a Song

A song consists of all the elements of a project. Patterns and parameter settings are all contained within a song and can be saved and loaded as required. Songs are autosaved. Up to 1000 songs can be stored. Composing will always be performed within a song. Song view is the default mode but if a track 1-4 is selected then track view will be active.

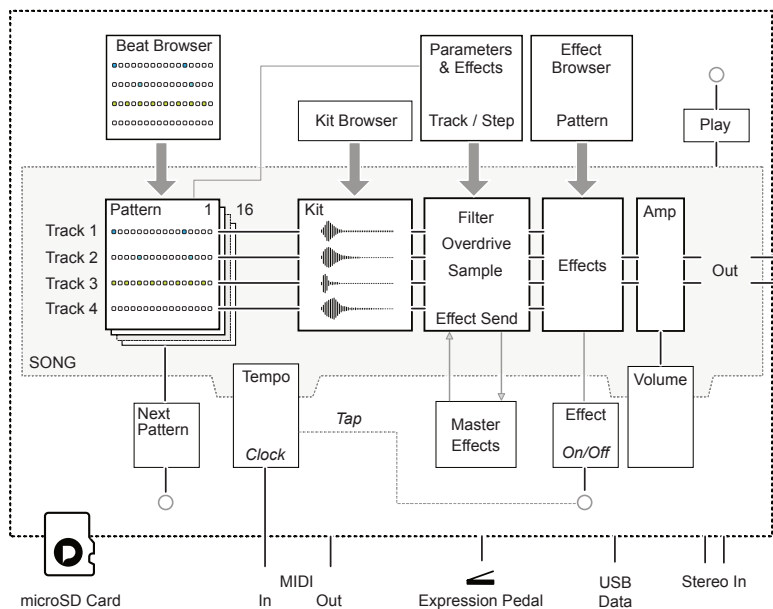

Song

Open a song: In song view, press or turn (Song) knob to open the song browser. Turn to navigate to an existing song. The song is immediately loaded when highlighted. An 'opening song' message is displayed on the screen



Song

Creating a song: In song view, press or turn (Song) encoder to open the song browser. Turn to navigate to an 'empty' song slot. The song is immediately created and loaded when highlighted. A 'creating new song' message is displayed on the screen. Default name is 'New Song' but this can be edited.



Next Pattern

Songs can also be changed with the {Next Pattern} footswitch. Press & hold {Next Pattern} to change the song.

Step Essentials

Beats & Kits

A beat is a pre-programmed pattern sequence based on a specific genre. Think of it as a library of pattern presets used to speed up workflow and get things started.

While the beat adds the rhythmic steps to a pattern, a kit adds the sounds. A kit is a collection of four sounds, each represented by a track. In song view, kits can be loaded to all four tracks simultaneously. If a track is selected and track view is active, only the track kit is changed.

Beats can be changed to try out different patterns with the same kit, or a beat can remain in place while experimenting with other kits. These combinations and the ability to manually edit patterns offer almost endless options yet keeps the workflow quick and straightforward.

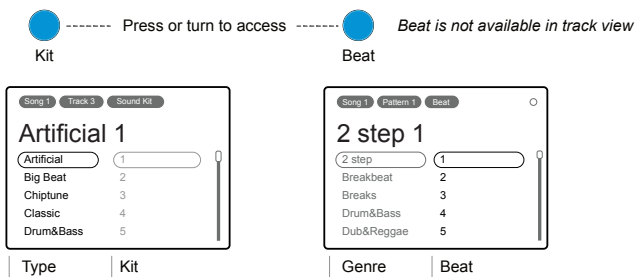

Press (Kit) knob to choose between 'Type' and 'Kit' options.

Turn (Kit) to navigate & select.

Press (Beat) knob to choose between 'Genre' and 'Beat' options.

Turn (Beat) to navigate & select.

A beat or kit is selected and loaded immediately when it is highlighted during navigation. The list of beats and kits is a long and complete list and will automatically navigate through the genre and type categories while scrolling the list.

Beat example: Artificial 1



Beat example: 2 step #1



Kits are sample based. Sample format is 16 Bit Mono.

Summary of factory pack beats and kits

Beat Genre	No of Beats
2-Step	8
Breakbeat	8
Breaks	64
Drum & Bass	16
Dub & Reggae	21
Electro	8
Electronica	16
Garage Rock	9
Glitch	16
Hip hop	10
House	16
Jazz	16
Kit A	16
Latin & Exotic	13
Pop Rock	15
Post Rock	16
Punk	16
Techno	8
Trap	6
Weird	50

Kit Type	No of Kits
808	8
909	8
Artificial	15
Big Beat	7
Chiptune	10
Classic	7
Drum & Bass	10
Dub & Reggae	10
Dubstep	10
Foley	13
Garage	10
Glitch	15
Hip hop	11
House	10
Industrial	10
Jazz	10
LoFi	10
Melodic HiFi	10
Melodic LoFi	9
Minimal	10
Noise	10
Pop Rock	11
Techno	10
Trap	10

Song	Song
New Car	Halfet
Steppa	Noise
Fidelity	Chip-n-Roll
Function	Jackin_
Da House	Industry
Pimerius	Softstep
Tribal Break	Shchewpeed
Loser	The Game
Andre 2000	Cosmos
Crystal	Jumperz

Step Essentials

Working with Patterns & Tracks

Each of the four tracks has a 16-step sequence that, when combined, forms a pattern. Think of this as a kit of four drums, for example, a kick, snare, hat, and tom, across the four tracks with a rhythm created by triggering the steps in the pattern. A pattern can be manually created or generated using a beat preset. Each song has 16 patterns, and switching between patterns enables variations and progressions to be introduced throughout a song. Patterns created in Polyend Play can also be used in Step.

Managing patterns

Example has 3 patterns 1, 2 and 16. Pattern 1 currently active as a starting point.

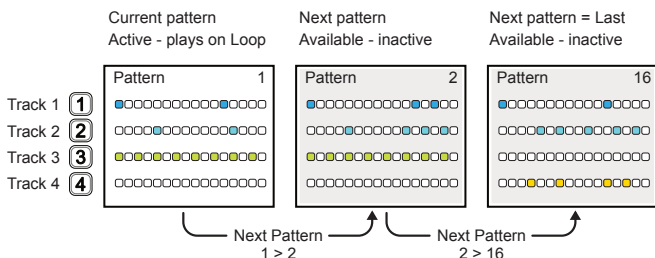

Selecting any pattern: Tap [Pad] 1-16. Must be in song view, no track selected.



Selecting the next pattern: Tap {Next Pattern} foot switch.

Selects only the next available pattern (lit dimly) and skips empty (unlit) patterns. The currently selected pattern is shown with the brightly lit pad. Use the foot switch while playing or stopped. If a pattern is playing the next pattern is cued (footswitch LED flashes) until the current pattern ends.

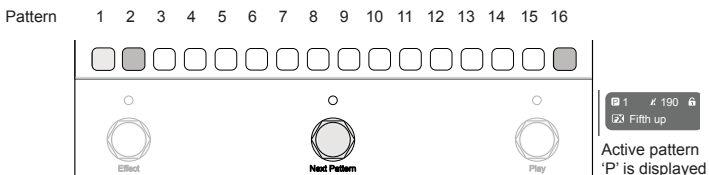



+ Delete a pattern: In song view, keep hold [Pad] for the pattern to delete, then hold (Effect) knob.

+ Copying a pattern: In song view, keep hold [Pad] for the source to copy until it turns blue, then press [Pad] for the destination to paste the pattern. Then release holding the first pad.



Sequencing of patterns is performed in track view. This means one of the 4 tracks must be selected to edit and create steps in the pattern manually. Note that turning the beat and song selection knobs are inactive in track view. Add steps to create a pattern. Using a beat is an alternative, quick method of making patterns and a good starting point. A beat is a preset pattern that can be loaded from the list of beat genres. Loading a beat is performed in song view and cannot be performed in track view.

Creating Patterns

-  Load a beat: Turn (Beat) to open the browser. Tap (Beat) to switch between the genre category or beat option. A beat is loaded immediately it is selected. *Beats apply a preset pattern across a selection of tracks. The beat can then be used directly or edited for further use. Beats cannot be loaded in track view. Steps can be manually added to a blank pattern to create a pattern from scratch*

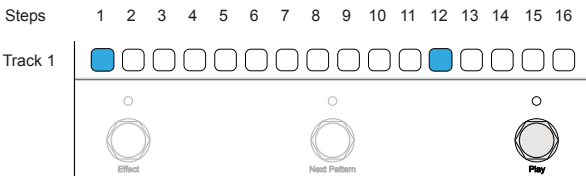
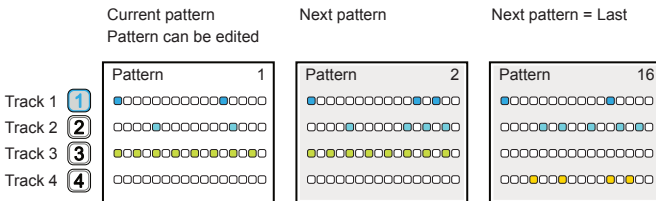
-  Select track view: Tap [Track 1] or another track to select for editing. *When in track view, the 16 Pads represent the steps in the track pattern. The currently selected pattern can be edited. Only one track can be selected at a time.*



-  Apply a step trigger: Tap [Pad] to add or remove a step trigger. *Active steps are lit by the same colour as the selected track*
-  Play: Tap {Play} foot switch to start or stop pattern playback, LEDs white. To play all patterns in sequence in song mode, press & hold {Play}, LEDs orange.

Step Essentials

Track / Step Parameters

The behavior for the steps in each track can be edited when in track view. A track must be selected, and the (Effect) Knob can be used to edit the step parameters for the track. Steps placed in the pattern will apply these settings. Note that existing steps will remain with the settings as originally placed unless edited. Some options can be set for the entire track.

Press [Track X] to select track view for tracks 1 to 4 to edit.

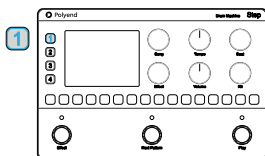

Button and pads are lit in the track color when track view is selected.

 Press or turn to access Effect

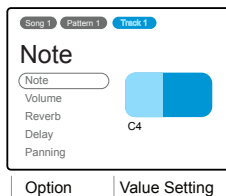

















Press (Effect) knob to choose between 'Option' and 'Value Setting'

Turn (Effect) to navigate and select an option or adjust a value. Press & hold the knob to reset some values.

When creating a pattern, steps will be placed with the parameter assignments that are currently active. The parameters can be set prior to placing steps. These can also be edited post-placement individually to create variations in a pattern by holding a step and adjusting the value. For example, the volume level can be varied for a hi-hat run.

Examples: Track 1 - Pattern 1

																
Note	C4			E4				C4			G4		C4			
Micromove	0/24			11/24				0/24			-11/24		0/24			
Chance	Always			70%				Always			Always		90%			
Track Length	----- 14 -----															

 +  Copying a step: Keep hold [Pad] source until it turns white, then press [Pad] for the destination.

Track Parameter and effect options

Parameters are available when a track is selected in track view. Parameters can be edited for a selected step by pressing or turning the (Effect) knob. Applies to defined steps or track.

Option	Range	Description
Note	No note, C#-1 to B8	Sets the note value for the step. C4 default.
Volume	-Inf dB to 12 dB	Sets the volume level for the step. 0dB default.
Reverb	0-100%	Reverb send amount. Master Effect. 0% default.
Delay	0-100%	Delay send amount. Master Effect. 0% default.
Panning	100L - Center - 100L	Panning position in the stereo field. Center is default.
Filter Cutoff	No Filter, 0-100 for HPF and LPF	High Pass or Low Pass Filter Cutoff. No filter is default.
Filter Resonance	0-100%	Filter resonance amount. 0 is default.
Bit Depth	4-16 Bits	Bit depth setting. 16 Bits is default.
Overdrive	0-100%	Overdrive effect. Amount applied. 0% is default.
Sample Start	Based on sample	Position of sample start in ms. Default is 0.
Sample End	Based on sample	Position of sample end in ms. Default is highest ms.
Microtune	-100 to +100	Note pitch micro tuning adjustment. Default is 0.
Sample Fade In	0.0% to 100.0%	Amount of fade in applied at sample start. Default is 0.0%.
Sample Fade Out	0.0% to 100.0%	Amount of fade out applied at sample start. Default is 0.0%.
Repeat Type	Options	Selects from a collection of repeat styles. Default is Off.
Repeat Grid	Options	Selects from the 'X Hits Y Steps' grid models. Default is Off.
Chance	Options	Probability of step playing. Default is 'Always'.
Action	Options	Assigns a playback action to a step. Default is 'Play Step'.
Micromove	-11/24 to 11/24	Moves step timing earlier or later. Default is 0/24 - On grid.
Track Length	1-16 Steps	Adjusts number of steps used in the track. Default 16.
Track Speed	Note intervals	Adjusts the note resolution / speed for the track. Default is 1.
Track Swing	25% to 75%	Swing setting for the track. Default is 50% - No Swing.
Track Volume	0-100%	Volume level for track. Default is 100%.

Step Essentials

Pattern Punch-In Performance Effects

A set of punch-in performance effects is provided, which can be triggered while playing a pattern. The pattern performance effects can be punched in and out using the {Effect} foot switch and are applied to all tracks. An effect can be loaded from the effect browser accessed using the (Effect) knob and is assigned per pattern.

The behavior of effects will depend on the current state of the track view. Track view is on when a track is selected. When no track is selected, Step defaults to song view. The pattern punch-in effects described here are available for editing when Step is in song view and not in track view, where the effect is applied across all tracks in the current pattern. Playback operates in any mode. It is possible to carry over the effect to the next pattern or only use it in a single pattern while it plays.

 Press or turn to access.
Effect

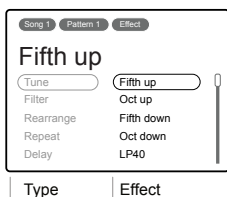

Press (Effect) knob to choose between 'Type' and 'Effect' options.

Turn (Effect) to navigate and select an effect for the pattern, all tracks.

While playing use the {Effect} switch to punch in / out.

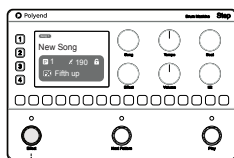

 Punch In - On or Off
Hold {Effect} to apply while held.
Tap {Effect} to latch effect on/off.

Only applies during playback

LED is lit when the effect is on.

An effect is only applied when the {Effect} foot switch is activated. If a new effect is selected in the browser list, the effect must be re-triggered by pressing {Effect} off and on to activate. The list of effects is a long, complete list of options and will automatically navigate through the types while scrolling through the list.

Note: if Step is not playing, the effect foot switch will operate as a tap tempo entry button.

In any track view, the effect punch-in and punch-out playback control can be applied. There are several applications, each of which affects how the effect is used. Control orientates around using the {Effect} foot switch and the behavior of each effect, assigned per pattern.

Playing back

Toggle Punch In - On or Off



Tap {Effect} foot switch to punch in.
Tap {Effect} again to punch out.

Temporary Punch In



Hold {Effect} foot switch to punch in.
Release {Effect} to punch out.

Current Pattern Punch In



Next Pattern

Tap {Next Pattern}, then tap {Effect}.
Effect is active only while current pattern plays.
Effect & LED turns off at the pattern change.

LEDs flash while the effect is on.

Next Pattern Punch In



Effect

Next Pattern

Tap {Effect}, then tap {Next Pattern}.
Current effect continues to the next pattern as long as the {Effect} switch is latched. Press {Effect} again to restore the original effect for the pattern.

Playback Stopped

Tap Tempo x4 Presses



Tap {Effect} foot switch to capture a BPM.

Step Essentials

Master Effects

The master effects consist of several functions, including delay and reverb. They are presented with a number of preset algorithms for quick setup. A custom parameter option is also available, which can be set in the main menu settings. The delay and reverb effects operate in a send / return arrangement. Tracks or individual steps can route an amount of audio to the reverb or delay algorithm, and the affected audio is fed back into the main mix.



Press or turn to access

Song

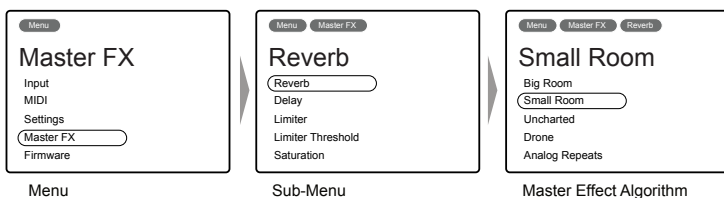

Navigate and select within the menu structure using the (Song) knob

The selected algorithm will process any audio sent to the effect. The Step parameter controls the amount of audio sent to the delay and reverb Master FX. Other Master FX, such as the limiter, operate in line with the main audio signal path. The effect algorithm parameters can be edited using the custom parameter option in the master FX menu.

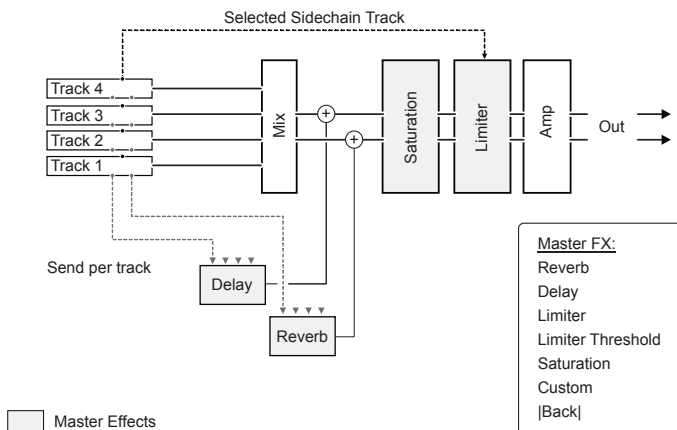

MIDI Interface

Step can send and receive MIDI messages through the MIDI 3.5mm Jacks. MIDI Type A or B can be used for MIDI In and type B for MIDI Out or the USB-C interface can send and receive MIDI messages. Step responds to program change, PC messages to switch songs and control change, CC messages to change patterns. Also clock and transport can be managed internally or by using an external MIDI controller.

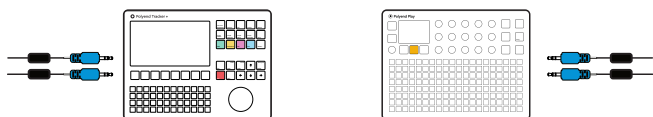

MIDI TRS
In/Out Interface to other audio gear

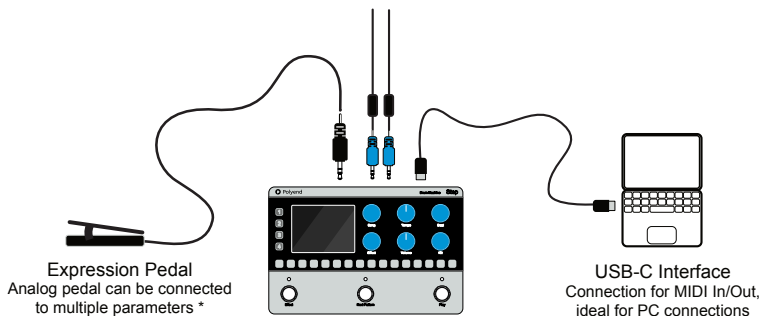

* If the volume parameter is assigned to the expression pedal, the expression device must be plugged into Step to control the volume, otherwise the volume level will be set to zero level.

Clock and Transport

To control Step play start / stop and tempo, configure the external MIDI settings for the port connected which sends the respective messages. Also Step can send clock and Transport out to other devices, also set up in the MIDI configuration.

Step will react to MIDI messages received on any of the 16 standard MIDI channels.

Step Essentials

Changing songs with PC messages

A MIDI PC message received by Step will change the song. This selection of song is based on the MIDI channel and the PC number* received. The following calculation is used to determine which song to select: 1-1000. The PC message will either select an existing song or create a new song in the song location chosen.

$$\text{Song} = ((\text{MIDI Channel \#} - 1) \times 128) + \text{PC Value Received}$$

Example: Channel 1, PC 5 = $((1-1) \times 128) + 5 = \text{Song 5}$

Example: Channel 2, PC 3 = $((2-1) \times 128) + 3 = \text{Song 131}$

Changing patterns with CC messages

A MIDI CC message received by Step will change the pattern. This selection of pattern is based on the value received on MIDI CC #1. Values ≥ 67 will increment to the next pattern. A value < 67 will switch to the previous pattern.

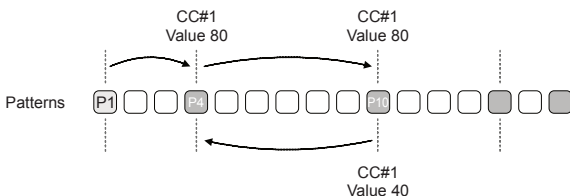

* Note that the PC number issued from a device should be checked with respect to its alignment with Step. Some devices start PC numbering at 0 while others start at 1. It is good practice to test the gear set up to ensure the values match.

Main Menu Options

Several global options are available in the main menu, accessible by holding the (Song) knob. Navigation and selection are performed by turning or pressing the (Song) knob. Selecting a menu option may specify a parameter to edit or navigate into a sub-menus. A 'Back' option to backup in the menu structure or an 'Exit' option may also be available in the menus.



Song

Hold to access main menu.

Turn (Song) to navigate and press to select a sub-menu or option.

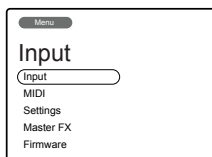

Song

Option	Range	Description
Rename & save		Opens the naming screen and allows renaming and saving.
Lock	Select	Sets lock mode on. Disables autosave.
	Deselect	Deselects lock mode. Autosave is active.
Humanize	Off	No variation is applied.
	Low	A low amount of variation is applied to the song velocity and timing.
	Medium	Medium variation is applied to the song velocity and timing.
	High	A low amount of variation is applied to the song velocity and timing.
Back		Command to back up to the main menu level in the structure.

Input

Option	Range	Description
Mode	Instrument	Sets the input ready for a instrument input i.e. guitar.
	Line	Sets the input ready for a line input i.e. synth.
Channels	Mono	Sets the 'Stereo Input' source to accept mono TS signal.
	Stereo	Sets the 'Stereo Input' source to accept a stereo TRS signal.
Expression Pedal	Off	A connected expression pedal is not assigned to a parameter.
	Volume	Expression pedal input is assigned to control global volume level.
	Filter	Expression pedal input is assigned to control filter cutoff.
	Tune	Expression pedal input is assigned to control pitch range.
	Tune+	Expression pedal input is assigned to control pitch - wide range.
	Overdrive	Expression pedal input is assigned to control overdrive amount.
	Reverb	Expression pedal input is assigned to control delay send amount.
	Delay	Expression pedal input is assigned to control delay send amount.
Back		Command to back up to the main menu level in the structure.

Step Essentials

MIDI

Option	Range	Description
Clock In	Internal	Time based functions e.g. tempo, use the internal clock.
	Jack	Time based functions e.g. tempo, use an external clock connected to the MIDI jack input. Tempo displays 'Ext' if clock is recognised.
	USB	Time based functions e.g. tempo, use an external clock input connected to the USB. Tempo displays 'Ext' if clock is recognised.
Transport In	Off	External transport functions e.g. play are off and ignored.
	Jack	Transport functions e.g. play, are controlled from an external device connected to the MIDI jack input.
	USB	Transport functions e.g. play, are controlled from an external device input connected to the USB.
PC In	Off	External program change functions are off and ignored.
	Jack	Program change messages to change the song are controlled from an external device connected to the MIDI jack input.
	USB	Program change messages to change the song are controlled from an external device input connected to the USB.
	USB & Jack	Program change messages to change the song are controlled from an external device input connected to the MIDI jack or the USB.
CC In	Off	External control change functions are off and ignored.
	Jack	Control change messages to change the pattern are controlled from an external device connected to the MIDI jack input.
	USB	Control change messages to change the pattern are controlled from an external device input connected to the USB.
	USB & Jack	Control change messages to change the pattern are controlled from an external device input connected to the MIDI jack or USB.
Clock Out	Off	The internal clock is not transmitted out.
	Jack	The internal clock is transmitted out from the MIDI jack output.
	USB	The internal clock is transmitted out from the USB output.
	USB & Jack	The internal clock is transmitted on the MIDI jack and USB output.
Transport Out	Off	The internal transport controls are not transmitted out.
	Jack	The internal transport play/stop controls are transmitted out from the MIDI jack output.
	USB	The internal transport play/stop controls are transmitted out from the USB output.
	USB & Jack	The internal transport play/stop controls are transmitted on the MIDI jack and USB output.
Back		Command to back up to the main menu level in the structure.

Settings

Option	Range	Description
Leds Brightness	High	Brightest setting for LEDs.
	Medium	Medium LED brightness.
	Low	Lowest setting for LEDs.
Knob Preview	Off	Audio preview is muted when changing knobs or selecting steps.
	Stopped	Audio is previewed when selecting tracks, steps, and changing step parameters if playback is stopped.
	Playback	Audio is previewed when selecting tracks, steps, and changing step parameters only when playing.
	Always	Audio is previewed when selecting tracks, steps, and changing step parameters both when playing or stopped.
Back		Command to back up to the main menu level in the structure.

Master FX

Option	Range	Description
Reverb	Options	Collection of reverb algorithm presets.
Delay	Options	Collection of delay algorithm presets.
Limiter	Options	Collection of limiter algorithm presets.
Limiter Threshold	0dB to -90dB	Sets the threshold level of the limiter.
Saturation	Options	Collection of saturation algorithm presets.
Custom Params	Reverb	Customisable parameters for reverb damping, size, diffusion and predelay.
	Delay	Customisable parameters for delay sync rate, feedback, ping pong, ping pong ratio and filter frequency.
	Limiter	Customisable parameters for limiter attack, release, sidechain and sidechain track.
Back		Command to back up to the main menu level in the structure.

Firmware

Option	Range	Description
Update Firmware	Command	Initiates the selection of a firmware file from the microSD card in order to update the firmware version.
Version	Indicator Only	Information of current firmware version.
Build	Indicator Only	Build version of current firmware version.

Step Essentials

Firmware Update

Polyend may periodically provide firmware updates to fix bugs or add new features. The updating process can be performed in several ways. You are strongly advised to follow the Polyend instructions supplied with each update when performing updates. The instructions here are a generic guide only. Register your product and subscribe at the Polyend site to access updates and further information.

FIRMWARE UPDATE

1. Download the latest firmware from your Polyend account.
2. Copy the downloaded .pstf firmware file into the /Firmware folder. This can be found in the root directory of the microSD Card.
3. Insert the microSD card into Step and power up.
4. Hold (Song) knob to open the main configuration and settings menu.
5. Navigate through to highlight the 'Firmware' sub-menu. Open the 'Update Firmware' function, highlight the firmware version to install.
6. Press (Song), knob to select firmware.
7. The firmware will install and the on screen prompts provided will guide. The install process is typically less than 1 minute.
8. Step will restart automatically when complete.

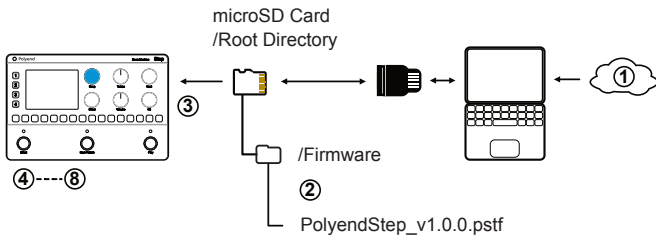

Changelog

OS & Manual	Feature Update	Manual Update
1.0.0 c		Changelog added (This table) for OS and content updates. Page 27.
		PSU. Added clarification on centre positive and negative options. Page 4.
		Sample format 16 Bit mono. Page 3 & 12.
1.0.0 d		Genres, beats and songs listed, Page 13 added and following pages reordered.
		Expression pedal volume clarification. Page 21 updated.
		Delete pattern added. Page 14
		Various minor style changes and PDF bookmarks added. References to the 'Big Beat', beat genre changed to '2-step'.
1.0.0 e		H/W Overview. Clarity on reset. USB MIDI.

Copyright © 2025 by Polyend

All rights reserved. This book or any portion thereof may not be reproduced or used in any manner whatsoever without the express written permission of the publisher except for the use of brief quotations in a book review.

Produced in the United Kingdom

June 2025 - Step 1.0.0 e

www.synthdawg.com

Synthdawg

 **Polyend**

