

# CyDrums

## Manual

Rev.1

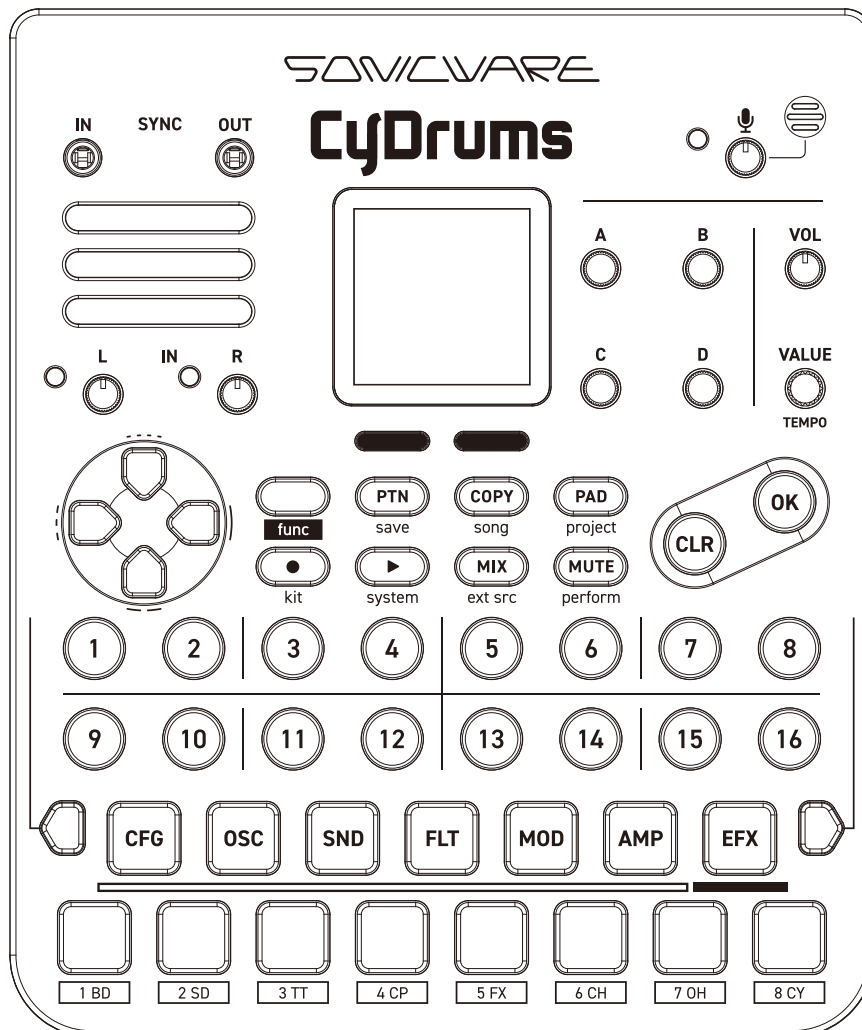

---

## FCC regulation warning (for USA)

Note: This equipment has been tested and found to comply with the limits for a Class B digital device, pursuant to part 15 of the FCC Rules. These limits are designed to provide reasonable protection against harmful interference in a residential installation. This equipment generates, uses and can radiate radio frequency energy and, if not installed and used in accordance with the instructions, may cause harmful interference to radio communications. However, there is no guarantee that interference will not occur in a particular installation. If this equipment does cause harmful interference to radio or television reception, which can be determined by turning the equipment off and on, the user is encouraged to try to correct the interference by one or more of the following measures:

- Reorient or relocate the receiving antenna.
- Increase the separation between the equipment and receiver.
- Connect the equipment into an outlet on a circuit different from that to which the receiver is connected.
- Consult the dealer or an experienced radio/TV technician for help.

## Legal disclaimers

Sonicware Inc. (hereafter, "SONICWARE" ) strives to assure that this document is as accurate and current as possible, but will bear no responsibility for any compensation claims or losses due to content included in this document. Moreover, information in this document could be changed without notice. SONICWARE retains the right to change product specifications and programs at any time. SONICWARE will bear no responsibility for any errors depicted in this document.

SONICWARE will bear no responsibility for any losses resulting from the use of this information, functions or due to product functions or performance, regardless of contracts, lack of caution or other conduct.

## Copyrights and registered trademarks

- SONICWARE is a registered trademark of Sonicware Inc.
- MIDI is a registered trademark of the Association of Musical Electronics Industry (AMEI).
- Other company names, product names, standard names and registered trademarks in this document are the property of their respective owners.
- All the trademarks and registered trademarks in this document are not intended to violate the copyrights of their owners, but rather are included for the purpose of identification only.
- Recording from copyrighted sources, including audio files, CDs, records, videos, tapes, broadcasts, streamed content and works of art, without permission of the copyright holder for any purpose other than personal use is prohibited by law.
- Sonicware Inc. will not assume any responsibility related to infringements of copyrights.
- The content, either built-in or included in this product (such as PCM sample data, audio data, and sound or pattern program data, etc.) is copyrighted by SONICWARE Inc. or is used under a license from a third party.

Any musical works created or performed using these contents with this device can be freely recorded and distributed. However, it is strictly prohibited, regardless of whether the content is used as is or altered in format, to license, transfer, sell, resell, redistribute, lend, rent, lease, transmit, enable downloading from or uploading to servers, or use the content in competitive products, including but not limited to actual instruments and collections of sampling data.

---

## Important safety precautions

You must read the following precautions in order to use the product safely and prevent accidents.

### **WARNING !**

**Failure to follow these precautions could result in serious harm to the user or even death.**

- Operation using an AC adapter

Do not do anything that could exceed the ratings of outlets and other electrical wiring equipment.

Disconnect the AC adapter from the outlet when lightning occurs and when not using it for a long time.

- Operation using batteries

Use-commercially available 1.5V AA batteries.

Carefully read the precautions of the batteries being used.

Be sure to insert the batteries with +/- ends oriented correctly.

Do not use new and old batteries together. Do not use batteries of different types together.

Remove the batteries when they will not be used for a long time.

If a leak occurs, thoroughly wipe the battery compartment and battery terminals to remove the leaked fluid.

- Do not open the case and disassemble or modify the product.

- Do not drop, strike or apply excessive force to the unit.

- Do not put liquid on or in the unit.

- Do not put foreign objects into the case.

- Do not use at a loud volume. Doing so could generate loud volumes that might lead to hearing loss.

- When transferring this unit, use the individual packing box and cushioning material that it came with when purchased new.

- When the unit is powered on, do not wrap it in cloth, plastic or other materials.

- Do not step on or apply pressure to the power cord.

- Do not use in the following environmental conditions. Doing so could cause malfunction.

Locations in direct sunlight, environments that exceed 40° C, or near stoves and other heat sources

Locations with extremely low or high temperatures

Locations with extremely high humidity or where the product could become wet

Locations with frequent vibrations or much dust or sand

- If the unit becomes broken or malfunctions, immediately turn the power off and stop using it.

### **Usage Precautions**

Failure to follow these precautions could cause injury to the user and physical damage.

- When connecting cables or working with the power of the unit, minimize the input levels of connected devices or turn them off.

- Cleaning

If the screen or the case become dirty, wipe them gently with a soft cloth.

Do not use chemicals, including alcohol, benzene, thinner or cleansers.

If this does not clean them, wipe them with a slightly damp cloth that has been wrung out well.

Do not turn the power on until the product is completely dry.

# Introduction

---

Thank you very much for purchasing a SONICWARE CyDrums.

The CyDrums is not analog or not analog modeling but A next-gen Digital Drum Synthesizer powered by dual wavetable oscillators.

We hope you enjoy using it for many years.

## Key features of the CyDrums

---

- **4D Drum Sound Evolution**

Wavetable x Velocity & Pressure Modulation = 4D Drum Sounds That React, Transform, and Evolve

- **22 Custom-Built Sound Structures**

22 Sound Structures Tailored to Each Instrument for Endless Sonic Possibilities

- **Versatile Effects & Flexible Routing**

Two Insert Effects, Reverb, and Master Effects with Flexible Routing for Versatile Sound Processing

- **Powerful 8-Track Beat Making**

Non-Stop, Intuitive Beat Making Powered by an 8-Track Drum Sequencer

- **Endless Creative Possibilities**

Generative Patterns with Randomization and Probability, Plus Numerous Performance Features incl. VariSpeed and Snip Loop

## Perform live anywhere

CyDrums is designed for inspiration anywhere—from your living room to the outdoors.

## Seamless Integration with Your Setup

TRS analog output, digital output via USB, MIDI in/out, and AudioSync for effortless DAW and hardware compatibility.

# Contents

<b>Key features of the CyDrums</b> .....	<b>4</b>	sound patch .....	27
<b>Names of parts</b> .....	<b>8</b>	Muting tracks .....	28
<b>Connection example</b> .....	<b>10</b>	Setting Global mute .....	29
<b>Basic Operations – General</b> .....	<b>11</b>	Using the D-pad Roll .....	30
Preparing a power supply .....	11	Playing in PAD mode .....	31
Starting up .....	11	Setting how the track will sound .....	32
Turning the unit off .....	11	GLIDE setting .....	33
<b>Basic Operations</b> .....	<b>12</b>	Legato setting .....	33
Adjusting the overall volume .....	12	Changing scale .....	34
Adjusting the speaker and headphones		Playing held notes .....	37
volume .....	12	<b>DrumKit function</b> .....	<b>38</b>
Direction, OK and CLR buttons .....	12	basic operations in DrumKit Select menu	38
Control and VALUE knobs .....	13	Loading the DrumKit .....	39
Function button .....	13	Saving the edited pattern as a DrumKit	39
15 PADs .....	14	<b>Functions of Parameter Pads</b> .....	<b>40</b>
PARAMETER PAD .....	14	<b>CFG (Configuration) page</b> .....	<b>40</b>
TRACK PAD .....	14	Sequence settings .....	40
<b>CyDrums Project Structure</b> .....	<b>15</b>	Copying and extending sequences .....	41
Project overview .....	16	Setting sequencer effects .....	42
Track overview .....	16	<b>OSC page</b> .....	<b>43</b>
Pattern overview .....	16	Editing a Wavetable oscillator .....	43
Song overview .....	16	Wavetable list .....	44
Patches overview .....	17	Direction to scan the wavetable .....	47
DrumKit overview .....	17	Editing the Noise oscillator .....	49
<b>Pattern Playback and Basic Functions</b>	<b>18</b>	Editing the Tick oscillator .....	50
Common display items on the screens	18	<b>SND (Sound) page</b> .....	<b>51</b>
Selecting patterns .....	19	<b>SND (Sound) page – Structure edit –</b>	<b>52</b>
Playing patterns .....	19	Editing structure .....	52
Selecting pattern 17 and higher .....	19	Change the structure .....	54
Reloading patterns .....	20	<b>SND (Sound) page – Sound patch</b>	
Adjusting the volume of individual patterns	20	<b>search –</b> .....	<b>55</b>
Play a pattern from another project	21	Enter to SOUND PATCH SEARCH .....	55
Tempo menu .....	22	SOUND PATCH SEARCH operation	55
Changing the tempo .....	23	Tagging sound patches .....	59
Setting the swing .....	23	<b>FLT (Filter) page</b> .....	<b>60</b>
Setting the metronome .....	23	Editing the filter .....	60
Setting the pre-count .....	23	Adjusting filter envelopes .....	61
MIXER .....	24	<b>MOD (Modulation) page</b> .....	<b>62</b>
Adjusting the mixer .....	24	Editing the velocity modulation .....	62
External input function .....	25	Editing the Aftertouch modulation .....	63
<b>Track Operations</b> .....	<b>27</b>	Adjusting modulation envelope .....	64
Selecting the track and changing the		The parameters assignable as the	

# Contents

modulation target .....	65	once .....	96
<b>AMP page .....</b>	<b>68</b>	<b>Parameter Locking – Real-time input</b>	<b>97</b>
Editing envelope, panning and volume	68	Inputting in real time (parameter recording)	97
Editing the output BUS routing, reverb		<b>Editing Sequences .....</b>	<b>98</b>
send and side chain send setting ...	70	Editing step data.....	98
Selecting track output BUS .....	71	MICRO TIMING .....	99
Setting the send signal amount to the		Editing Step Data .....	100
Reverb .....	72	Clearing steps .....	102
Setting the Sidechain Compressor Trigger		Clearing track data .....	102
Signal .....	72	<b>Copy Functions .....</b>	<b>103</b>
<b>EFX (Effect) page .....</b>	<b>73</b>	Copying track settings to another ...	103
Effect routing .....	74	Copying one track to another .....	103
Setting the effect .....	76	Copying steps .....	103
Editing the reverb .....	78	<b>Copy Functions .....</b>	<b>104</b>
Editing the Master FX .....	79	Copying the sequence page settings to	
<b>Select the EFX patch .....</b>	<b>82</b>	another.....	104
Selecting EFX patch 17 and higher	82	<b>Saving and Managing Patterns .....</b>	<b>105</b>
<b>Managing EFX patch .....</b>	<b>83</b>	Saving patterns .....	105
Basic operation in EFX PATCH SELECT	83	Saving patterns with EFX patch .....	106
Storing edited EFX setting as EFX patch	84	Clearing (initializing) patterns .....	107
Import a EFX patch.....	85	Renaming patterns.....	108
Export a EFX patch.....	85	Editing tracks within a pattern .....	109
<b>Creating Patterns .....</b>	<b>86</b>	Swapping tracks .....	110
<b>Step Sequencer Overview .....</b>	<b>86</b>	Copying tracks .....	111
Overview .....	86	Moving tracks .....	112
CyDrums step sequencer features ...	86	Clearing tracks .....	113
<b>Creating Sequences – Step recording</b>	<b>88</b>	<b>PERFORMANCE mode .....</b>	<b>114</b>
Basic operations .....	88	Activate Performance mode .....	114
Selecting steps 17 and higher .....	89	Stutter playback across all tracks ...	117
Inputting tied-notes (long sounds) ...	90	<b>SONG .....</b>	<b>118</b>
<b>Creating Sequences – Real-time</b>		Playing songs .....	118
<b>recording .....</b>	<b>91</b>	Editing songs .....	119
Basic operations .....	91	SONG EDIT operations .....	120
<b>Creating Sequences – Direct recording</b>	<b>92</b>	Renaming songs .....	123
Basic operations .....	92	Clearing songs .....	124
Clearing a note .....	93	Copying a song .....	125
Clearing tied notes .....	93	<b>Managing Projects .....</b>	<b>126</b>
<b>Parameter Locking .....</b>	<b>94</b>	Creating new projects .....	126
<b>Parameter Locking – Direct input</b>	<b>95</b>	Saving projects .....	127
Using direct input .....	95	Saving as a different project .....	128
Clearing parameter lock information	96	Renaming projects .....	129
Clearing all locking for any parameter at		Deleting projects.....	130

# Contents

<b>Managing sound patches</b> .....	<b>131</b>	Checking system version information	165
Loading the selected Sound Patch into the track .....	131	<b>Firmware updates</b> .....	<b>166</b>
Saving a sound patch .....	132	<b>If an error message appears during startup</b> .....	<b>167</b>
Renaming the sound patch name ..	133	<b>Appendix</b> .....	<b>168</b>
Deleting a sound patch .....	133	Sound architecture .....	168
Import a EFX patch from external memory Card .....	134	<b>Structure List</b> .....	<b>169</b>
Export a sound patch .....	136	BD STANDARD .....	169
<b>Managing DrumKits</b> .....	<b>137</b>	BD FM .....	172
Import a DrumKit from external storage Card .....	137	BD METALIC .....	175
Export a DrumKit .....	137	SD STANDARD .....	178
<b>Importing various data at once</b> .....	<b>138</b>	SD FM .....	181
Importing Sound Patches at once ..	138	SD TONE .....	184
Importing DrumKits at once .....	139	RS STANDARD .....	187
Importing EFX Patches at once .....	140	CP STANDARD .....	190
<b>Clock Synchronization with External Devices</b> .....	<b>142</b>	TT STANDARD .....	193
Connecting with other devices .....	142	PC STANDARD .....	196
<b>MIDI</b> .....	<b>145</b>	PC COWBEL .....	199
Setting track MIDI channels .....	145	SY STANDARD .....	202
Setting MIDI channels for the unit ..	146	SY BASS .....	204
Making other MIDI settings .....	148	AC STANDARD .....	206
Editing MIDI NOTE MAP .....	151	CH STANDARD .....	208
<b>Changing mute mode</b> .....	<b>153</b>	CH METALLIC .....	211
<b>Pad sensitivity setting</b> .....	<b>154</b>	CH CLASSIC .....	214
Pad Velocity Sensitivity .....	154	OH STANDARD .....	217
Changing the Pad Aftertouch Curve	155	OH METALLIC .....	220
<b>Deactivating PAD transpose setting</b>	<b>157</b>	CY STANDARD .....	223
<b>Mute the internal speaker</b> .....	<b>158</b>	CY CLASSIC .....	226
<b>Disabling to switch the page in page select menu</b> .....	<b>159</b>	CY RIDE .....	228
<b>Card functions</b> .....	<b>160</b>	<b>Hardware Specifications</b> .....	<b>231</b>
Card reader mode .....	160		
Testing card performance .....	161		
<b>Changing POWER Settings</b> .....	<b>162</b>		
Battery setting .....	162		
Automatic power off function .....	163		
<b>Resetting the unit to the factory default state</b> .....	<b>164</b>		
<b>System information</b> .....	<b>165</b>		

# Names of parts

## Right side

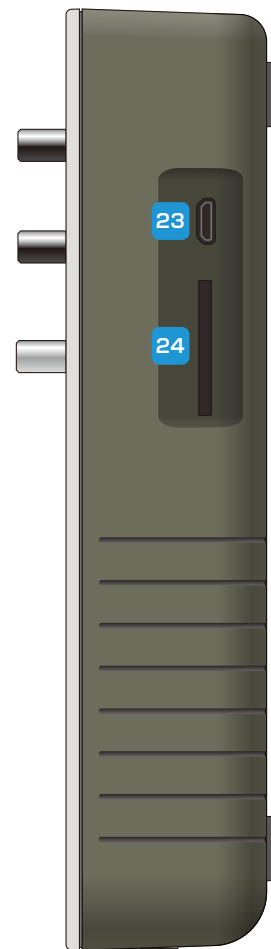
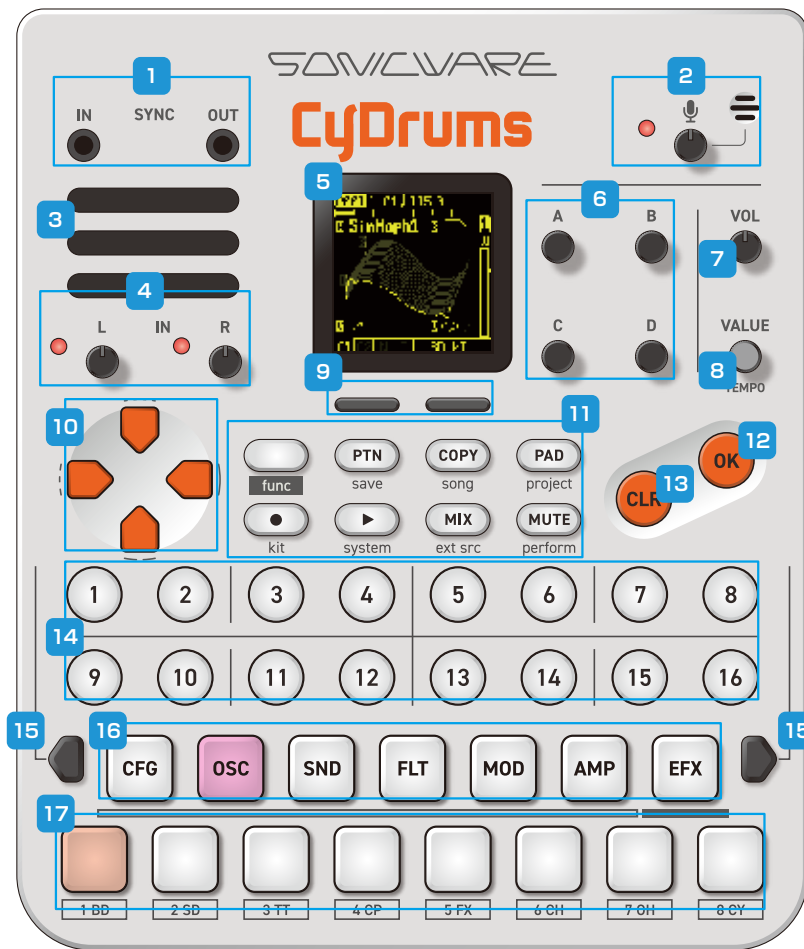

## Rear

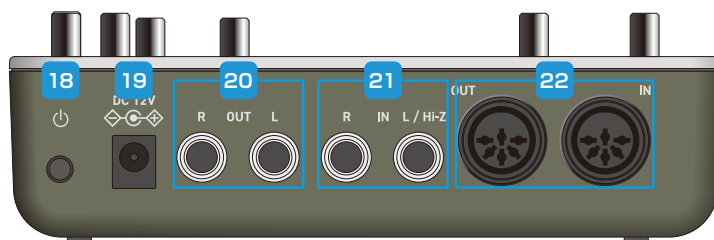

## Front

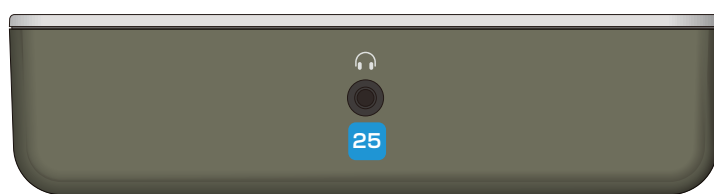

# Names of parts

<b>1 : SYNC In/Out</b> Input and Output for SYNC signals.	<b>2 : Mic</b> Built-in Mic with gain knob to adjust input volume.	<b>3 : Speaker</b> Built-in speaker.	<b>4 : Recording gain knobs</b> Adjust input volume of INPUT L and R.
<b>5 : Display</b>	<b>6 : Control knobs</b> Turn-and-press type knobs for A-D parameters on the screen.	<b>7 : VOL knob</b> Adjust headphones and speaker volume.	<b>8 : VALUE knob</b> Adjust master volume. Press to open the TEMPO MENU. This knob is also the Tempo LED.
<b>9 : Auxiliary buttons</b> Select items displayed at the bottom of the screen.	<b>10 : D-pad</b> Use for 7 re-trigger divisions from 8th to 64th notes. And menu cursor movement and item selection.		
<b>11 : function button</b> Press this button with other buttons to switch to the submenu.	<b>PTN</b> Press this button with other buttons to switch to the submenu.	<b>COPY</b> Copy & Paste Tracks, Parameters or Steps.	<b>PAD</b> Switch to PAD mode.
	<b>save</b> Open the PATTERN SAVE menu.	<b>song</b> Open the SONG SELECT menu.	<b>project</b> Open the PROJECT MENU.
<b>REC</b> Record sequence data.	<b>Play</b> Play/Stop a pattern or song.	<b>MIX</b> Launch the MIXER.	<b>MUTE</b> Mute the track(s).
<b>kit</b> Open the Drum Kit menu	<b>system</b> Open the SYSTEM MENU.	<b>ext src</b> Open the USB & EXT IN page.	<b>perform</b> Switch to Performance mode.
<b>12 : OK</b> Use to confirm option selections in menus.	<b>13 : CLR</b> Use to cancel a step or exit from a menu screen.	<b>14 : STEPs</b> Press with the Track Pad: Direct data entry. <i>Press function button simultaneously to edit the data.</i>	
<b>15 : Page Switches</b> Select the page(bar) to edit. <i>In PAD mode, these become scale shift switches.</i>	<b>16 : Parameter Pads</b> Press to open parameter pages for editing. <i>Press the function button simultaneously to select in PAD mode.</i>	<b>17 : Track Pads</b> Select a TRACK and trigger its sound. <i>Press the function button simultaneously to select without sounding.</i>	<b>18 : Power Switch</b> Press and hold to power on and off.
<b>19 : DC12V</b> Connect DC power supply.	<b>20 : Output L/R</b> Stereo line level audio output.	<b>21 : Input L/R</b> L Input can be connected to an E.Guitar.R Input can be connected to a Dynamic Microphone.	<b>22 : MIDI In/Out</b> Input and Output for MIDI signal.
<b>23 : USB Connector</b> Connect to PC to manage data and use Audio Interface function.	<b>24 : Storage Card</b> CyDrums internal data storage card.	<b>25 : Headphone Out</b> Stereo headphones output.	

# Connection example

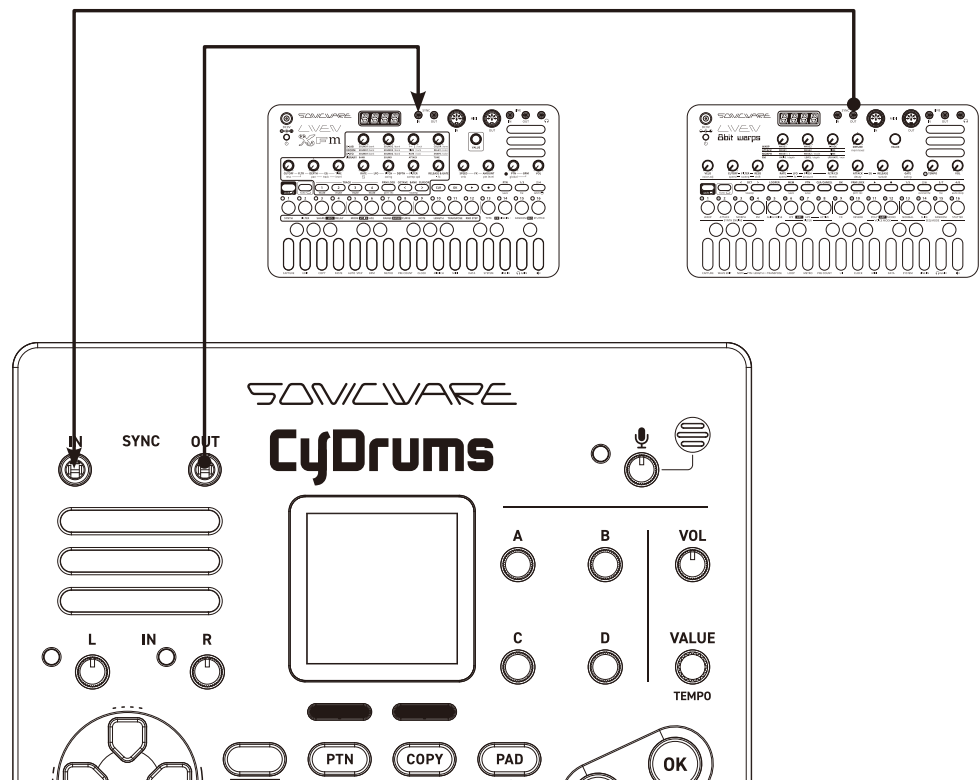
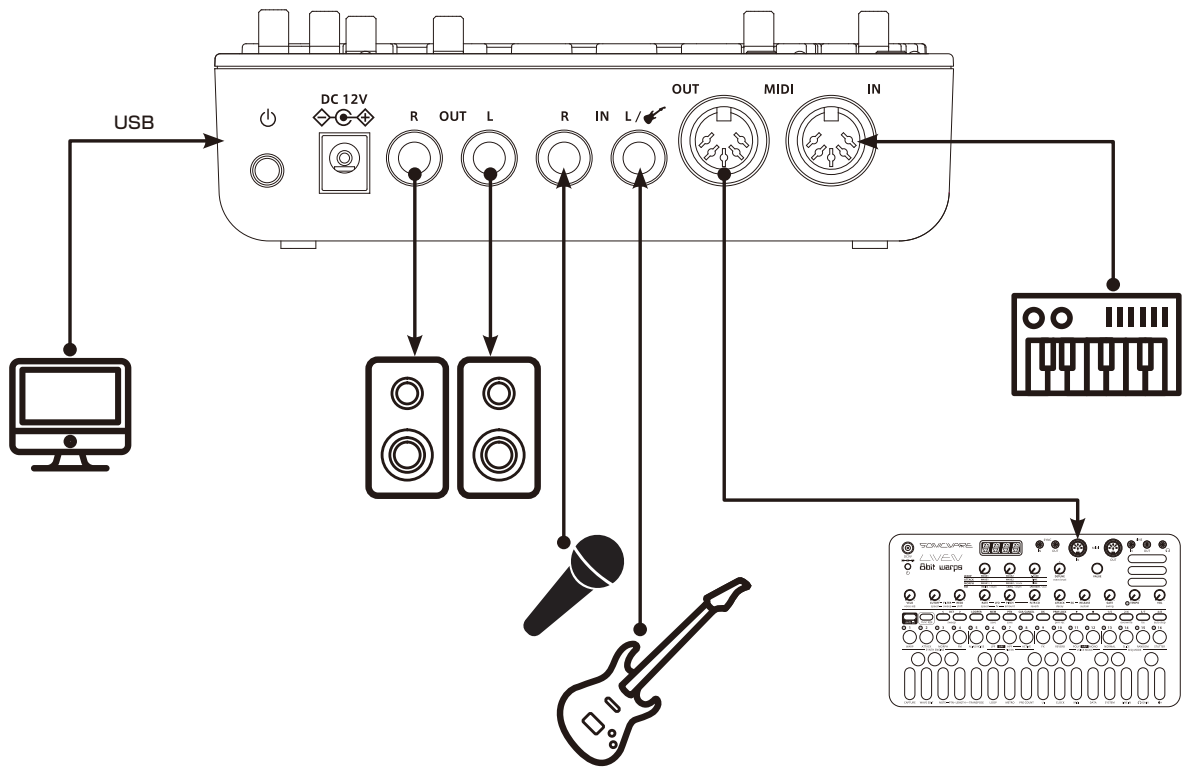

# Basic Operations – General

---

## Preparing a power supply

An AC adapter is included.

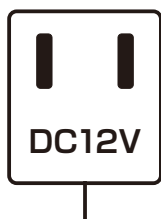

or

6 AA batteries



**Use only the included AC adapter. Using an AC adapter with different specifications could cause damage.**

The following Battery Low icon will appear on the display if the remaining battery charge is low. Replace the batteries immediately.



When using nickel-metal hydride batteries or lithium batteries, change the battery setting.  
(→ P.162)

## Starting up

- 1 Press and hold the POWER switch until CyDrums appears on the display.



## Turning the unit off

- 1 Press and hold the POWER switch until the display turns off.

# Basic Operations

---

## Adjusting the overall volume

The volume from the speaker, headphones and the LINE OUT can be adjusted.



Master Level	
0 - 127	This can be adjusted from $-\infty$ to +3 dB with 0 dB as the middle value (100).

## Adjusting the speaker and headphones volume





The volume from the speaker and headphones can be adjusted.



Speaker/HeadPhone Volume	
	This can be adjusted from $-\infty$ to +6 dB with 0 dB as the middle value.

If you want to always mute the built-in speaker without connecting headphones, see "Muting the built-in speaker". (→ P.158)

## Direction, OK and CLR buttons

To keep this manual from becoming too complex, not every item that can be operated using the direction,  and  buttons is explained. On many screens, the direction,  and  buttons can be used in addition to the knobs, in order to navigate menus, confirm selections, or cancel operations, respectively.

# Basic Operations

---

## Control and VALUE knobs

Use the Control and VALUE knobs to change/adjust parameters shown on the screen.

These knobs are also switches. They are mainly used in the following two ways.



Turn



Push

If a parameter has a control knob with a downward pointing arrow, that parameter can be turned on/off, or have its function switched, by **pushing** it.

## Function button

Some CyDrums buttons have two functions.

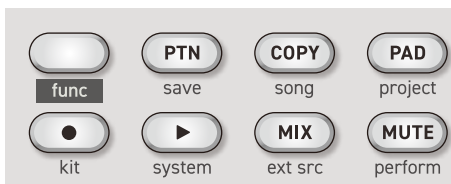

In the example above, the secondary functions of the **PTN** and **COPY** buttons are “save” and “song”.

Pressing these buttons while pressing the **func** button will engage their secondary functions (opening the menus for pattern saving and song selecting, respectively).

In this manual, operations that require pressing the **func** button will be shown as follows.



By pressing the function button while turning knobs, values can be skipped. Parameters with large value ranges, for example, can be set quickly by pressing the function button while operating their controls.

# Basic Operations

---

## 15 PADs

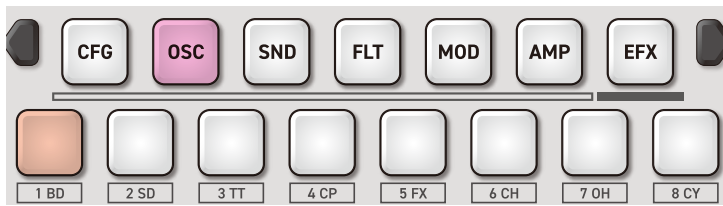

## PARAMETER PAD

Pressing these 7 parameter pads will open parameter editing pages. Some pages have sub-pages that can be opened by pressing the  Auxiliary buttons.

These sub-pages can also be opened by pressing the same parameter pad again.

## TRACK PAD

Press any of the 8 track pads to select a track and trigger the sample assigned to the track.

Edit each track by switching pages using the parameter pads.

# CyDrums Project Structure

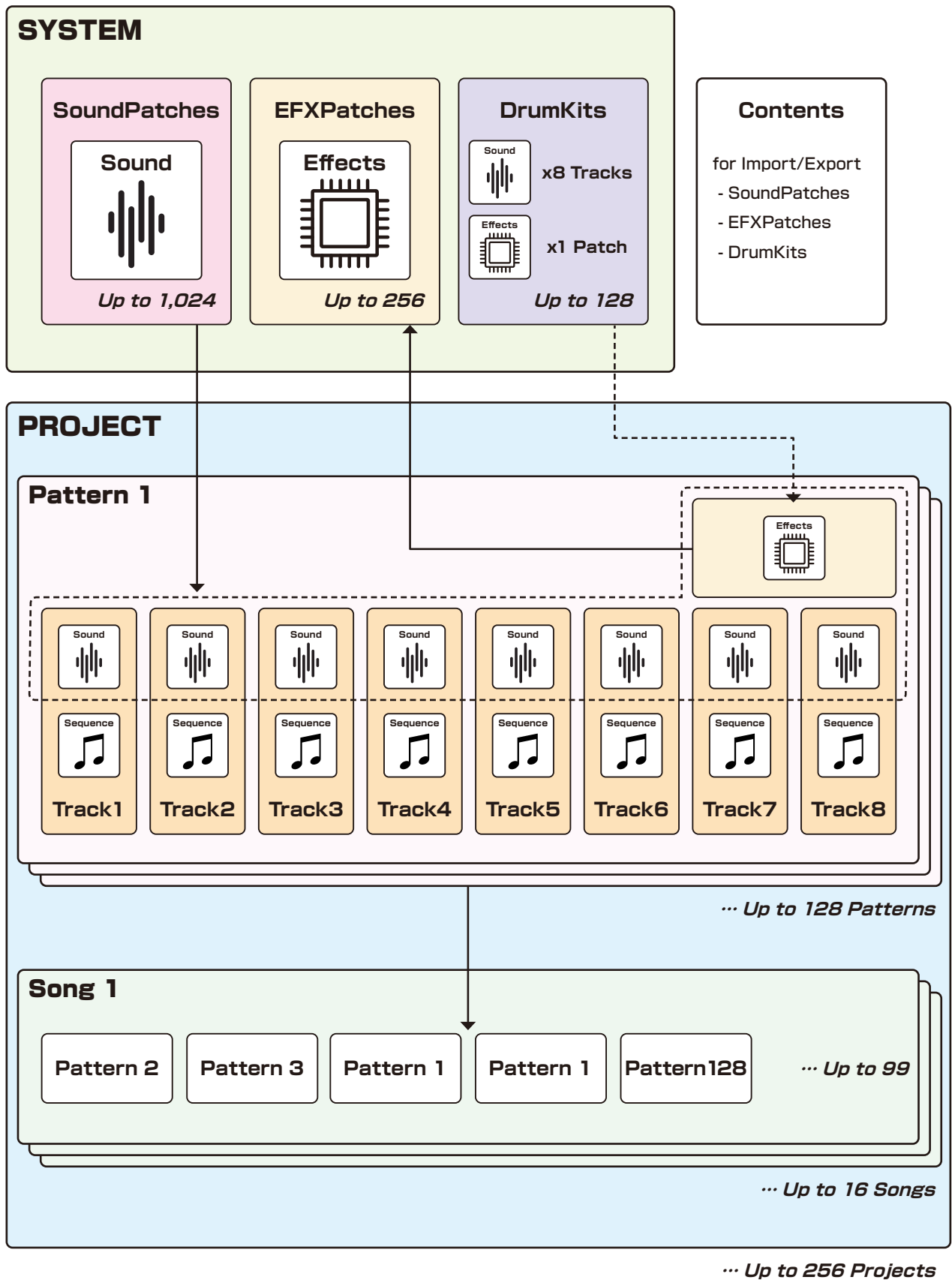

# CyDrums Project Structure

---

## Project overview

Projects are collections of patterns and songs which will be explained later.

All data used by the CyDrums is saved in projects except for the patches and the Drum Kits.

The CyDrums can save up to 256 projects.

## Track overview

The CyDrums is a groovebox with an 8-track sequencer.

Tracks contain both sound settings and sequences (performance data).

The 8 tracks of the CyDrums can each have sequences made with different sounds.

## Pattern overview

A pattern is a combination of the 8 tracks. With lengths of 1-128 steps, patterns can be used as the smallest units in making songs.

The CyDrums can save a total of 128 patterns in a project.

## Song overview

Songs can be played back as single pieces of music. The playback order and repetition of patterns along with the number of bars can be set for a song.

Each project can save up to 16 songs. Up to 99 patterns can be added to a Song.

# CyDrums Project Structure

---

## Patches overview

A sound patch contains sound setting data for a track, and an EFX patch contains EFX setting data.

### Sound patch

On each of the 8 tracks, you can load a preset sound patch or a sound patch that you yourself created.

The original data of the sound patch is copied to the pattern, so editing the sound patch in the pattern does not affect the original data.

If you want to use the edited sound in another pattern or project, please save it as a new sound patch. (→ P.132)

### EFX patch

In each pattern, you can load a preset EFX patch or a sound patch that you yourself created.

EFX patches operate globally, so if you save over the same EFX patch, the changes will be applied to all patterns and drum kits.

If you want to avoid this, please save your EFX settings as a new EFX patch. (→ P.84)

## DrumKit overview

A DrumKit is a combination of the sound settings for each of the 8 tracks and the current EFX settings.

By loading a DrumKit, you can quickly set the sound and EFX settings of a pattern.

Saving a pattern will not update the DrumKit parameters. These need to be saved separately.

The CyDrums can save up to 128 kits.

# Pattern Playback and Basic Functions

## Common display items on the screens

The CyDrums displays different items on the screen depending on the selected function, but the following display items are common.

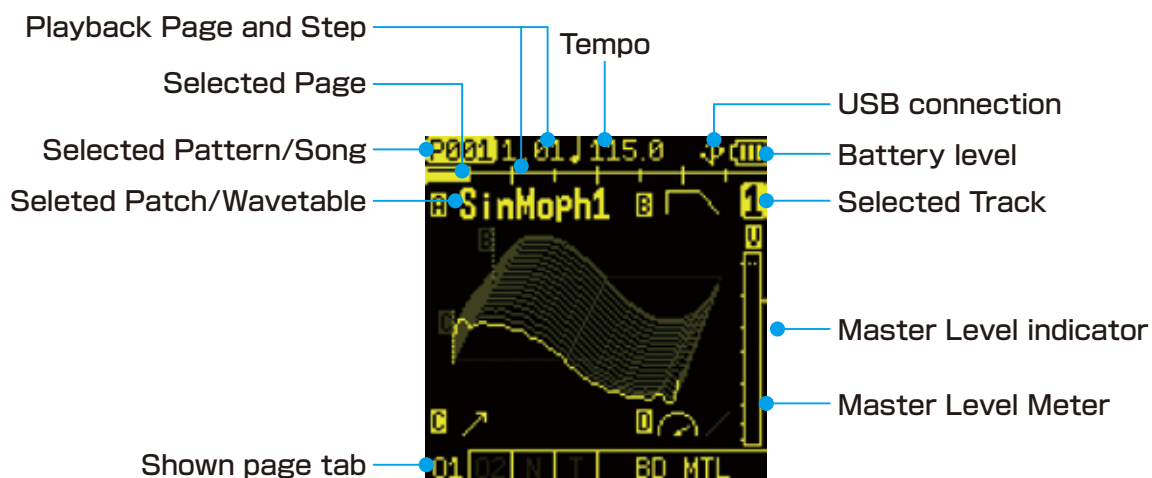

# Pattern Playback and Basic Functions

## Selecting patterns

- 1 Press **PTN** to open PATTERN SELECT.
- 2 Press **STEP**.  
This selects a pattern.  
(STEP 1 for pattern 1... STEP 16 for pattern 16)
- 3 Press the **OK** button to enter a pattern.

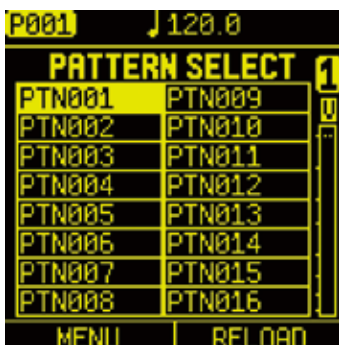

## Playing patterns

- 4 Press **PLAY**.  
Press **PLAY** again to stop.



- When you press the **OK** button in procedure 3, the default behavior is to return to the parameter editing page that was last open. However, this behavior can be changed in the system settings. (→ P.159)
- If a different pattern is selected during pattern playback, it will be readied but will not start playing immediately. Playback will switch to the selected pattern after the currently playing pattern completes playing.  
(You can also switch patterns immediately by pressing **func** + **OK**.)
- Press **OK** + **PLAY** to play a song. (→ P.118)
- Press **CLR** + **PLAY** to stop all sound immediately.

## Selecting pattern 17 and higher

Press page switches or **TRACK PADS** after procedure 1 to make the menu display the next 16 patterns, enabling the selection of pattern 17 and higher.

# Pattern Playback and Basic Functions

---

## Reloading patterns

- 1 Press **PTN**.
- 2 Press **Auxiliary right button RELOAD**.
- 3 Select the item to reload and press the **OK** button.

RELOAD	
SEQUENCE	Reload STEP DATA stored in the sequencer.
PARAMETER	Reload track settings.
ALL	Reload all settings and sequences in the pattern.

## Adjusting the volume of individual patterns

- 1 Hold **func** and turn **VALUE**.

PATTERN LEVEL	
0 - 127	Pattern levels can be set in a range of $-\infty$ - +3 dB. ( <i>The value 100 is 0 dB.</i> )

# Pattern Playback and Basic Functions

## Play a pattern from another project

1 Press **func** + **PAD** project to open the PROJECT MENU.

2 Select SELECT/NEW in the PROJECT MENU.



3 Select one of the preset projects and press the **OK** button.

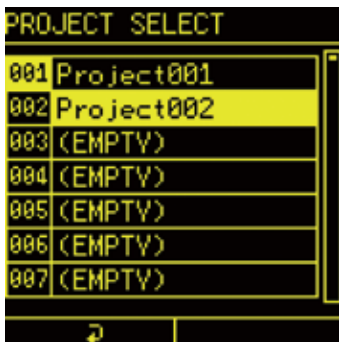

4 Select YES to save the current project and press the **OK** button.

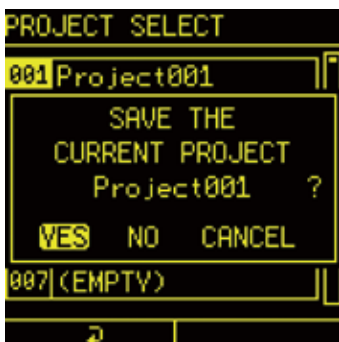

Once the project is opened, follow the ●STEPS on (→ P.19) to play a pattern.

# Pattern Playback and Basic Functions

## Tempo menu

- 1 Press VALUE to open the TEMPO MENU.  
Turn A - D knobs to edit.

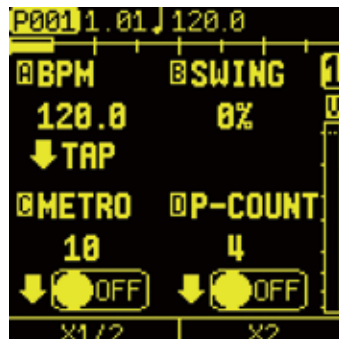
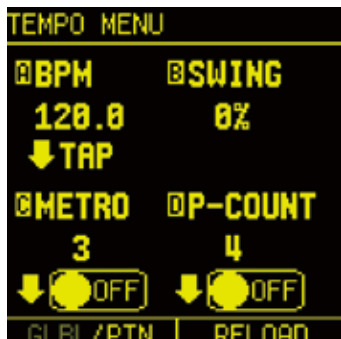



TEMPO MENU		
A knob	BPM	<b>40 - 250:</b> Set the pattern tempo
A (Push)	TAP	Set Tempo by tapping
B knob	SWING	<b>0% - 75%:</b> Set the SWING amount
C knob	METRONOME	<b>0 - 16:</b> Adjust Metronome volume
C (Push)	OFF/ON	METRONOME ON / OFF
D knob	P-COUNT	<b>1 - 16:</b> Set the pre-count number
D (Push)	OFF/ON	Pre-count ON / OFF
Auxiliary left button	GLBL, PTN	<b>PTN:</b> Whenever a different pattern is selected, the BPM is reset using the tempo saved in that pattern.  <b>GLBL:</b> The current global BPM value will continue to be used even when a different pattern is selected.

# Pattern Playback and Basic Functions

---



- Select global BPM mode to maintain a consistent tempo during the jam session. Use pattern BPM mode when you want the tempo to change with each pattern.
  - Press the  Auxiliary right button **RELOAD** to reload the pattern's TEMPO settings.
  - The tempo can be multiplied by x2 or divided by x1/2 by pressing  +  Auxiliary buttons.
- 

## Changing the tempo

- 1 Turn the  A knob in the TEMPO MENU to change the tempo. Turn it while holding down  to change in increments of 0.1.



## Setting the swing

- 1 Turn the  B knob in TEMPO MENU to adjust the SWING amount.





- SWING can be set for each track individually on the CONFIG page. ( → P.42)
- 

## Setting the metronome

- 1 Press the  C knob in TEMPO MENU to turn on the metronome.
- 2 Turn the  C knob to adjust the metronome volume.

## Setting the pre-count

- 1 Press the  D knob in TEMPO MENU to turn on precount.
  - 2 Turn the  D knob to set the precount number.
-

# Pattern Playback and Basic Functions

## MIXER

- 1 Press the **MIX** button to open the MIXER page.
- 2 Press a **TRACK PAD** to select that track for editing.

## Adjusting the mixer

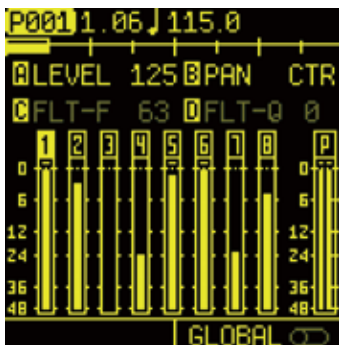

MIXER		
A knob	LEVEL	<b>0 - 127:</b> Track level
B knob	PAN	<b>L63 - L1, CTR, R1 - R63:</b> Track panning
C knob	FLT-F	<b>0 - 127:</b> Filter cutoff frequency About the filter setting (→ P.60)
D knob	FLT-Q	<b>0 - 127:</b> Filter resonance About the filter setting (→ P.60)
Auxiliary right button	GLOBAL OFF/ON	<b>OFF:</b> Use the settings saved in the pattern.  <b>ON:</b> The current settings are saved and used as global settings.

# Pattern Playback and Basic Functions

## External input function

CyDrums can use USB and external input audio.

The USB and analog inputs can also be sent to Reverb effects individually.



USB&EXT IN		
Ⓐ knob	ENABLE	<b>OFF, ON:</b> Turn ON/OFF input audio monitoring
Ⓑ knob	LEVEL	<b>0 - 127:</b> Adjust external audio level
Ⓒ knob	R-SND	<b>0 - 127:</b> Send amount from the EXT IN/USB to the reverb effect
Ⓓ knob	SOURCE SELECT	MIC (Built In) INST (Input L) MIC (Input R) STEREO MONO (Input L)
Ⓔ D (Push)	L,N,H/PAD	<b>Lo, Normal, Hi:</b> Switch the input gain.  <b>PAD:</b> Switch the input -20dB PAD ON/OFF.
Ⓕ Auxiliary right button	EXT IN/USB	<b>EXT IN:</b> EXT IN audio settings page  <b>USB:</b> USB audio settings page

# Pattern Playback and Basic Functions

---



- 
- When using analog inputs, use the Input gain knob to adjust the input level. If the Input gain is turned all the way to the left, no audio will be input.
-

# Track Operations



---

On the CyDrums, select between 8 track pads and use 6 track parameter pads and 1 effect setting pad to change settings. Pressing a  TRACK PAD will select the corresponding track and simultaneously play the loaded Patch sound.

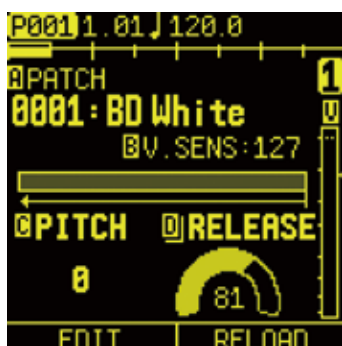

## Selecting the track and changing the sound patch

- 1 Press the  TRACK PAD to select the track. The assigned patch will play.



- 2 Press the  Pad and turn the  A knob on the SND page to select a sound patch.



- A track can be selected without playing the sound by pressing the  TRACK PAD while pressing the  button.
  - The  TRACK PAD that is the currently selected is lit orange.
-

# Track Operations

## Muting tracks

- 1 Press the **MUTE** button.
- 2 Press the  TRACK PAD(s) you want to mute.  
 TRACK PAD(s) for muted tracks will be lit yellow.  
Press yellow  TRACK PAD(s) to unmute that track(s).
- 3 Press **MUTE** (lit yellow) to exit MUTE mode

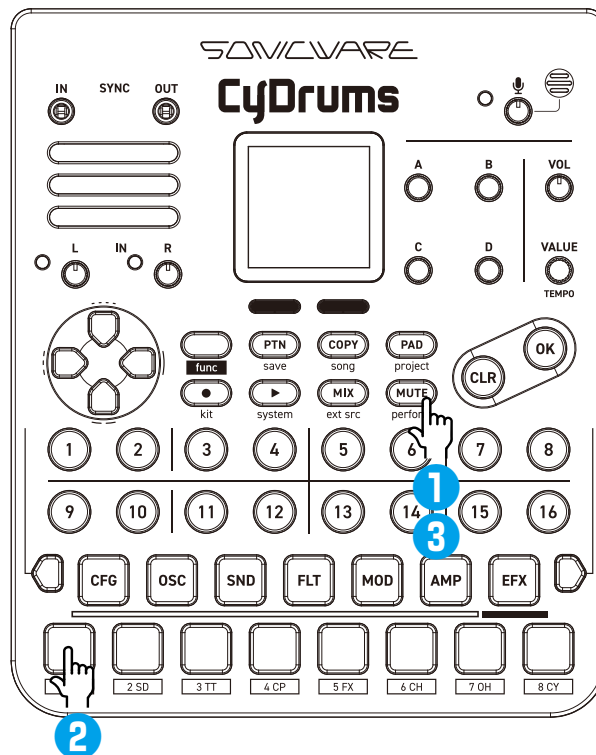

- By pressing a  TRACK PAD while holding the **MUTE** button, the selected track can be muted/unmuted directly.
- A track can be selected by pressing **func** +  TRACK PAD even in MUTE mode.
- By changing the mute mode setting (→ P.153), tracks can be played by pressing track pads, even if the tracks are muted.

# Track Operations

## Setting Global mute

- 1 Press **MUTE** to activate MUTE mode.
- 2 While pressing **OK** button, press the **TRACK PAD(s)** you want to mute.  
The muted **TRACK PAD(s)** light bright yellow.

The globally muted tracks will remain muted after pattern switching.

- 3 Press **MUTE** (lit yellow) to exit MUTE mode.

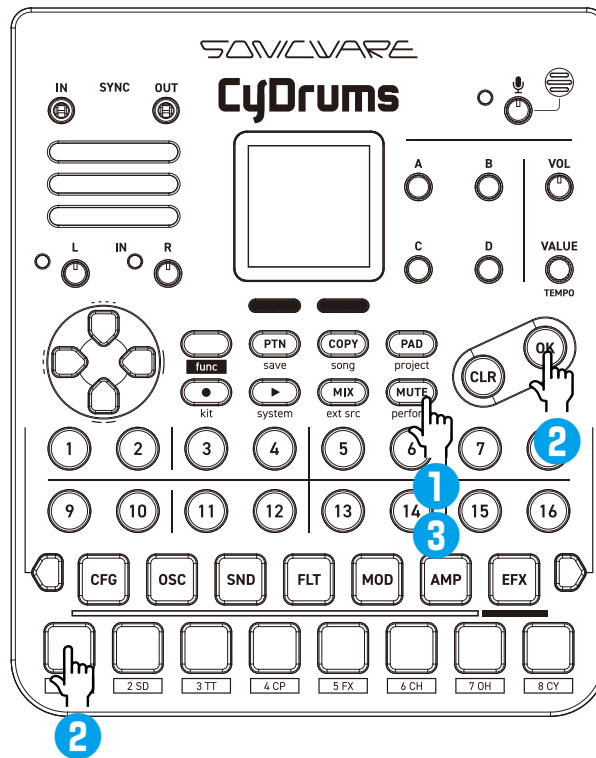

# Track Operations

---

## Using the D-pad Roll

The D-pad Roll can be played by pressing a  TRACK PAD while pressing D-pad direction buttons.

This operation can be also recorded in the sequencer.

D-PAD	
Right	8th note
Down + right	Quarter note triplet
Down	16th note
Down + left	8th note triplet
Left	32nd note
Up + left	16th note triplet
Up	64th note
Up + right	None



- While playing rolls, the roll speed will match changes made to the D-pad direction.
  - Dice function in CFG page (→ P.42) also affects the sound probability of roll performance when change.
-

# Track Operations

---

## Playing in PAD mode



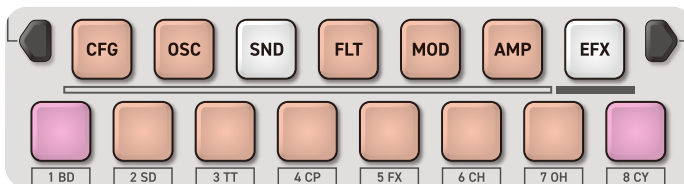

- 1 Press **PAD** to enter PAD mode and open the PAD page.  
By pressing the  auxiliary left button on the PAD page, you can open the normal screen while remaining in PAD mode.



While in PAD mode, you can play the currently selected sound in a scale with the 15 PADs. The PAD corresponding to the root note of the scale will be lit pink each octave.

Pressing the **PAD** again on the PAD page will return to normal mode.



- In PAD mode, you can open or switch parameter edit pages by pressing **func** + , the tracks by pressing **func** + , the pages by pressing **func** + .

# Track Operations

## Setting how the track will sound



PAD		
A knob	Scale	Select the scale shown for the <input type="checkbox"/> 15 PADs.
B knob	Key	<b>C,Db,D,Eb,E,F,Gb,G,Ab,A,Bb,B:</b> Set the root note of the scale shown by the 15 PADs.
C knob	Octave	<b>-5 - 0 - +4:</b> Select the range of the octave that is shown on the 15PAD.
D knob	Glide	<b>0 - 127:</b> Adjust the GLIDE speed.
Auxiliary right button	LEGATO	<b>OFF:</b> A single voice will be output and each note retriggers the sound.  <b>ON:</b> A single voice will be output and additional notes will not retrigger the sound.

# Track Operations

---

## GLIDE setting

- 1 Turn  knob on the PAD page to adjust the glide. The higher the value, the more glide there will be.

## Legato setting

Press the  Auxiliary right button to turn on or turn off LEGATO.

When LEGATO is on, playing additional notes will not re-trigger the sound.

When LEGATO is off, the sound will be re-triggered.

# Track Operations

## Changing scale

- 1 Operate  A knob on the PAD page.  
The scales that can be selected are as follows.

SCALE		
CHROMATIC	Chromatic scale	C,Db,D,Eb,E,F,Gb,G,Ab,A,Bb,B
MAJOR	Major scale	C,D,E,F,G,A,B,
MINOR	Minor scale	C,D,Eb,F,G,Ab,Bb
HARM. MINOR	Harmonic minor scale	C,D,Eb,F,G,Ab,B
MELO. MINOR	Melodic minor scale	C,D,Eb,F,G,A,B
DORIAN	Dorian scale	C,D,Eb,F,G,A,Bb
PHRYGIAN	Phrygian scale	C,Db,Eb,F,G,Ab,Bb
LYDIAN	Lydian scale	C,D,E,Gb(F#),G,A,B
MIXOLYDIAN	Mixolydian scale	C,D,E,F,G,A,Bb
LOCRIAN	Locrian scale	C,Db,Eb,F,Gb,Ab,Bb
SUP. LOCRIAN	Super Locrian scale	C,Db,Eb,E,Gb,Ab,Bb
MAJOR BLUES	Major blues scale	C,D,Eb,E,G,A
MINOR BLUES	Minor blues scale	C,Eb,F,Gb,G,Bb
DIMINISHED	Diminished scale	C,D,Eb,F,Gb,Ab,A,B
COM DIM	Combined diminished (octatonic) scale	C,D,Eb,E,Gb,G,A,Bb

# Track Operations

SCALE		
MAJ. PENTA	Major pentatonic scale	C,D,E,G,A
MIN. PENTA	Minor pentatonic scale	C,Eb,F,G,Bb
RAGA1	RAGA1	C,Db,E,F,G,Ab,B
RAGA2	RAGA2	C,Db,E,Gb,G,A,B
RAGA3	RAGA3	C,Db,Eb,Gb,G,Ab,B
ARABIC	Arabic scale	C,D,E,F,Gb,Ab,Bb
SPANISH	Spanish scale	C,Db,Eb,E,F,G,Ab,Bb
GYPSY	Gypsy scale	C,Db,E,F,G,Ab,B
MINOR GYPSY	Minor Gypsy scale	C,D,Eb,Gb,G,Ab,B
EGYPTIAN	Egyptian scale	C,D,F,G,Bb
HAWAIIAN	Hawaiian scale	C,D,Eb,F,G,A,B
PELOG	Pelog scale	C,Db,Eb,G,Ab
HIRAJOSHI	Hirajoshi scale	C,D,Eb,G,Ab
IN-SEN	Insen scale	C,Db,F,G,Bb
IWATO	Iwato scale	C,Db,F,Gb,Bb
KUMOI	Kumoi scale	C,D,Eb,G,A
MIYAKO BUSHI	Miyakobushi scale	C,Db,F,G,Ab
RYUKYU	Ryukyu scale	C,E,F,G,B
CHINESE	Chinese scale	C,E,Gb,G,B

# Track Operations

---

SCALE		
WHOLE TONE	Whole tone scale	C,D,E,Gb,Ab,Bb
WHOLE HALF	Whole-half scale	C,D,Eb,F,Gb,Ab,A,B
5TH INT.	5th interval	C,G



- For all of the scales except the chromatic scale, the  15 PADs are filled with only the notes in the note order of the selected scale
-

# Track Operations

## Playing held notes

- 1 Press **OK** + one or more of the **15 PADS**.  
This will hold the notes being played.  
Press the same pad again to release held notes.  
All held notes can be released by pressing **OK** + **CLR**.

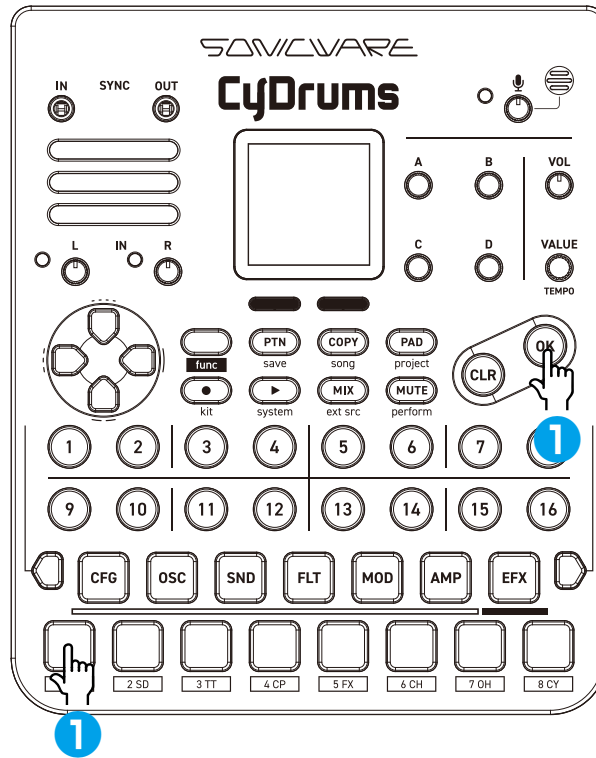

- You can hold playing rolls by pressing **OK** + D-pad + **15PAD**.

# DrumKit function

You can switch the pattern sounds of the CyDrums quickly with the DrumKit function.

It allows you to change all sounds and EFXs at once, while leaving the sequences of notes in the pattern unchanged.

You use it to find new inspirations.

## basic operations in DrumKit Select menu

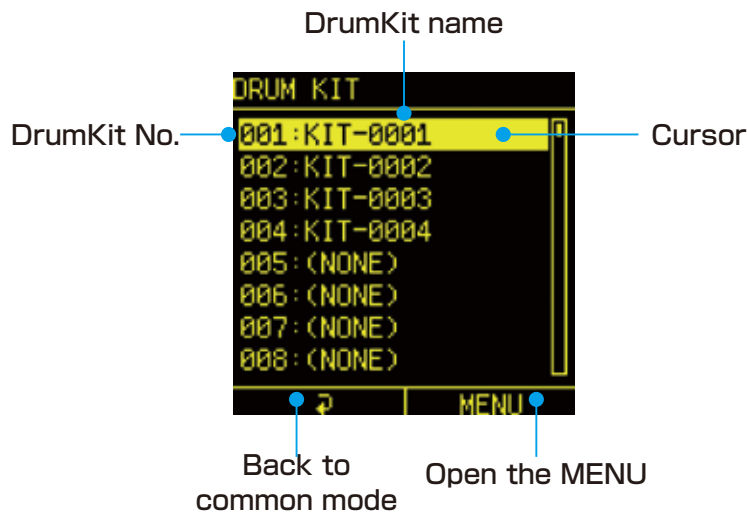

**1** Press **func** + **kit** button to open DRUM KIT page.

**2** Press **Auxiliary right button MENU** to open MENU.

DRUM KIT MENU	
LOAD	Load the selected DrumKit to the current pattern.
SAVE	Save the current pattern sound settings to the selected slot as DrumKit.
RENAME	Rename the selected DrumKit.
IMPORT	Import a DrumKit in the Contents folder of the External storage card to the selected slot.
EXPORT	Export a DrumKit to the Contents folder of the External storage card.

# DrumKit function

---

## Loading the DrumKit

- 1 Press **func** + **kit** button to open DRUM KIT page.
- 2 Press D-pad to select a DrumKit.
- 3 Press **OK** button to confirm the DrumKit.



## Saving the edited pattern as a DrumKit

- 1 Turn the **knob** to select the slot where you want to save the DrumKit.
- 2 Press **Auxiliary right button MENU** to open MENU.
- 3 Turn the **knob** to select SAVE and press the **OK** button.



- Only saving the DrumKit will not save the patterns. Similarly, saving the patterns will not save the DrumKit parameters. Be aware that they need to be saved individually. See "Saving patterns" (→ P.105)
-





## Functions of Parameter Pads / CFG (Configuration) page

On the CFG (Configuration) page, settings can be edited for track sounds and step sequencers as well as sequence effects.

Press the  pad to open the CFG page.



### Sequence settings



CONFIG-SEQ		
 A knob	LEN	<b>1 - 128:</b> Number of steps in sequence
 A (Push)	LEN multiplier	<b>× 1, × 8, × 16:</b> Change the number of steps that are increased or decreased at one time when the  knob is turned.
 B knob	NOTE	<b>Note length of step:</b> <b>1/1</b> (whole note) <b>1/2</b> (half note) <b>1/4</b> (quarter note) <b>1/2T</b> (half note triplet) <b>1/8</b> (8th note) <b>1/4T</b> (quarter note triplet) <b>1/16</b> (16th note) <b>1/8T</b> (8th triplet) <b>1/32</b> (32nd note) <b>1/16T</b> (16th triplet) <b>1/64</b> (64th note)

# CFG (Configuration) page

---



 C knob	TRANSP	<b>-24 - +24:</b> Track transposition setting (semitone) If you don't want the transpose setting to be reflected in the 15 PADs, turn off <b>TRANSP</b> in PAD settings in the SYSTEM MENU.
 D knob	CHOKE	<b>OFF:</b> Choke group not set.  <b>1 - 4:</b> When any track within the same choke group is triggered, another track that is currently sounding in the same choke group will be silenced (note-off).



-  and  are set to CHOKE 1 by default.
- 

## Copying and extending sequences





A sequence that has been created can be duplicated.

- 1 While pressing the  button, turn the  knob to duplicate. Each duplication will double the LEN setting.

# CFG (Configuration) page

## Setting sequencer effects

The CyDrums has sequence effects including Random, which can randomize phrases; Stutter, which repeats playback of pressed steps; and Dice, which sets the probability of notes playing.

CONFIG-GRV		
 A knob	SWING	<b>PTN:</b> Follow the amount of swing set in TEMPO MENU.  <b>0% - 75%:</b> This sets the amount of swing in current track. Ignoring the swing setting in TEMPO MENU.
 B knob	RND STP (enabled when RANDOM selected)	<b>OFF, 1 - 16:</b> This sets the minimum step unit for randomization during random playback.
 C knob	DICE	<b>25% - 100%:</b> The probability of a note sounding can be set to 25 - 100%.
 D knob	Q-TIZE	<b>0% - 100%:</b> Adjusts the quantize of the micro timing of the notes. At 0%, quantize is disabled and the sequence is played back as per the recorded micro timing. At 100%, quantize follows the beat.
 Auxiliary right button	SEQ MODE	<b>NORMAL:</b> Sequences will be played back normally.  <b>RANDOM:</b> Sequence phrases will be played back randomly.  <b>STUTTER:</b> Steps being pressed will play back repeatedly.

# OSC page

The oscillator settings can be made on the OSC (Oscillator) page. Press the **OSC** pad to open the OSC page. Edit the parameters with the knobs and the Auxiliary buttons.

## Editing a Wavetable oscillator

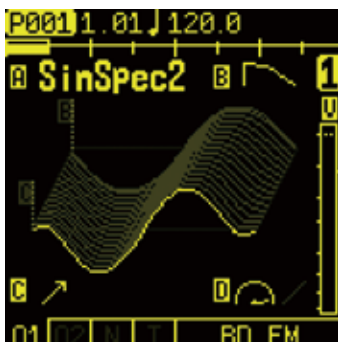

OSC1 & OSC 2			
A knob	Wave	1 - 64	Select a Wavetable.
A (Push)	Module Mute	Mute only the module signal currently shown on the page.	
B knob	Release	0 - 127	Adjust the release time. It can also be edited on AMP page. (→ P.68)
C knob	Direction	1 - 16	Select the way that the Wavetable will be scanned.
D knob	Speed	0 - 127	Adjust the speed at which the Wavetable will be scanned.
B (Push)	End	0 - 127	Adjust the end point of Wavetable scanning
C (Push)	Start	0 - 127	Adjust the start point of Wavetable scanning
D (Push)	Curve	-63 - 63	Adjust the curve of the speed of Wavetable scanning
Auxiliary left button	Switch the editing page tab.		
Auxiliary right button	Open Sound patch search.		
<b>func</b> +  Auxiliary right button	Open Structure select page.		

# OSC page

---

## Wavetable list

<b>Crush</b>	
A waveform created by harmonic morphing of basic waveforms. It's suitable for Bass Drums and more.	
SinCrsh1	SawCrush
SinCrsh2	
<b>Fold</b>	
A waveform created by applying random modulation to basic waveforms. With its intense changes, it's ideal for Strong Noise and as a modulation source for FM sound structures.	
SinFold1	SinFold2
<b>Shaper</b>	
A waveform created by transitioning basic waveforms into noise. With its shift to aggressive noise, it's ideal for snappy Snare Drums.	
SawShape	TriShape
<b>Duty</b>	
A waveform emphasizing harmonic frequencies. It's suitable for Chords and Percussion.	
SinDuty	TriDuty
SqrDuty	SawDuty
<b>Morph</b>	
A waveform created by harmonic morphing of basic waveforms. It's suitable for Bass Drums and more.	
SinMoph1	SawMoph1
SinMoph2	SawMoph2

# OSC page

---

## Wavetable list

<b>Spectrum</b>	
A waveform created by applying spectrum changes to basic waveforms. With subtle transformations, it's ideal for Bass Drums, Toms, and basic synthesis.	
SinSpec1	SawSpec2
SinSpec2	SqrSpec1
SinSpec3	SqrSpec2
SinSpec4	TriSpec
SawSpec1	
<b>Fomula</b>	
A waveform created by applying random modulation to basic waveforms. With its intense changes, it's ideal for Strong Noise and as a modulation source for FM sound structures.	
SinForm1	TriForm1
SqrForm1	TriForm2
<b>Complex</b>	
A waveform created with a combination of FM and bit-crush modulations. It's effective for adding intense changes to your sounds.	
SqrFM	FMcrush2
FMcrush1	FoldCrsh
<b>Overtone</b>	
A waveform emphasizing harmonic frequencies. It's suitable for Chords and Percussion.	
Harmonc1	HarmMoph
Harmonc2	
<b>Transform</b>	
A transformed waveform created by fading multiple waveforms. It's suitable for adding complex harmonic character to Synth Bass and Lead Synths.	
Trnsfrm1	Trnsfrm4
Trnsfrm2	Trnsfrm5
Trnsfrm3	Trnsfrm6

# OSC page









---

## Wavetable list









<b>Random</b>	
A waveform created by applying random modulation to basic waveforms. With its intense changes, it's ideal for Strong Noise and as a modulation source for FM sound structures.	
SawRand1	SinRand1
SawRand2	SinRand2
SawRand3	SinRand3
TriRand1	SqrRand1
TriRand2	SqrRand2
TriRand3	
<b>Sample</b>	
A sample waveform captured at a high sample rate. Adjusting the scan range and direction allows for various sounds.	
SmpSnare	SmpCrsh
SmpCymb1	
<b>Glitch</b>	
A waveform created by applying random modulation to basic waveforms. With its intense changes, it's ideal for Strong Noise and as a modulation source for FM sound structures.	
RndGlitch	SawGlitch
HarmGlitch	
<b>Noise</b>	
A waveform created by transitioning basic waveforms into noise. With its shift to aggressive noise, it's ideal for snappy Snare Drums.	
SqrNoiz1	SqrNoiz2
<b>Other</b>	
A waveform emphasizing harmonic frequencies. It's suitable for Chords and Percussion.	
Sweep	Noise2
Noise1	Noise3

## Direction to scan the wavetable

By setting the direction parameter, you can change the way that the Wavetable is scanned.

DIRECTION		
	Forward	Scan from Start point to End point.
	Backward	Scan from End point to Start point.
	Forward& Backward	Scan from Start point to End point. Then scan back to Start point.
	Backward& Forward	Scan from End point to Start point. Then scan back to End point.
	Sine	Scan in a round trip between Start point and End point. The scanning speed will slow down near the Start point and End point.
	Forward (Loop)	Scan from Start point to End point and then repeat doing so in a loop.
	Backward (Loop)	Scan from End point to Start point and then repeat doing so in a loop.
	Forward& Backward (Loop)	Scan from Start point to End point. Then scan back to Start point. Then repeat the same back and forth pattern in a loop.

# OSC page

DIRECTION		
	Backward & Forward (Loop)	Scan from End point to Start point. Then scan back to End point. Then repeat the same back and forth pattern in a loop.
	Sine (Loop)	Scan in a round trip between Start point and End point. The scanning speed will slow down near the Start and End points. Repeat in a loop.
	Random	Scan randomly between Start point and End point.
	Smooth random (0 start)	Scan between the Start and End point, starting with the Start point and then changing directions at random points.
	Smooth random	Scan between the Start and End point, starting from a random position and then changing directions at random points.
	Smooth random (Forward)	Scan from Start point to End point. Then turn around and continue to scan while changing directions at random points.
	Step 3	Repeatedly scan the 3 steps dividing the range of Start - End point.
	Step 4	Repeatedly scan the 4 steps dividing the range of Start - End point.

# OSC page

## Editing the Noise oscillator



This adds a transient, snappy or cymbal-like sizzling noise to the sound.

Press the  Auxiliary left button and select the [N] tab.

Noise		
Type	White, Pink, Brown, Purple, Resonance	Select the Noise type.
Frequency	0 - 127	Adjust the peak frequency of RESO Noise.
Level	0 - 127	Adjust the level of Noise.
Time	0 - 127	Adjust the length of time of the noise.

# OSC page

## Editing the Tick oscillator

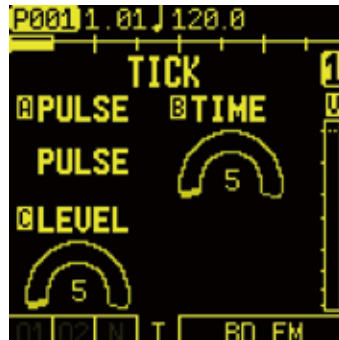

This adds a transient tick pulse to the sound.

Press the  Auxiliary left button and select the [T] tab.

Tick		
Pulse	Pulse, H-Saw, Rectangle, F-saw, Chev, Sine, Gaus, Rapid, Hi-F, Noise	Select the type of Pulse.
Time	0 - 127	Adjust the length of time of the Pulse.
Level	0 - 127	Adjust the level of the Pulse.



- The types of Pulse that you can select will vary, depending on the type of structure that you've selected. (→ P.169)









# SND (Sound) page

The oscillator settings can be changed on the SND (Sound) page.

Press the  pad to open the SND page.

Press the  Auxiliary left button to open the Structure edit page.



SOUND		
 A knob	Select a sound patch.	
 A (Push)	Open the Sound patch search ( → P.55)	
 B knob	Velocity Sens	<b>0 - 127:</b> Set the velocity sensitivity of the sound patch volume. This does not affect modulation.
 C knob	Pitch	<b>-60 - 0 - +60:</b> Set the base pitch of the sound patch, changing the pitch in semitone steps.
 D knob	Release	<b>0 - 127:</b> Set the release time of the sound patch. It can also be adjusted on the AMP page. ( → P.68)
 D (Push)	Volume	<b>0 - 127:</b> Set the volume of the sound patch. It can also be adjusted on the AMP page. ( → P.68)
 Auxiliary left button	EDIT	Open the structure edit page.
 Auxiliary right button	RELOAD	Reload the sound patch to the way it was the last time it was saved. Any edited parameters that have not been saved will be lost.

# SND (Sound) page – Structure edit –

## Editing structure

The Structure Edit page allows you to edit 22 different synth structures.

The Structures that form the core of the CyDrums' sound each have their own unique parameters, which you can edit to create your own synthesis.







All parameters in Structure Edit can be assigned modulation or controlled by MIDI CC, allowing you to create a wide range of sounds.

This page uses BD Standard as an example.

For an explanation of all structures, see the structure list. (→ P.169)





# SND (Sound) page – Structure edit –

SND			
 A knob	Sweep Time	0 - 127	<b>Adjust the time of the pitch sweep modulation.</b> The lower the value, the faster the sweep speed.
 B knob	Sweep Depth	Down63 - OFF - Up63	<b>Adjust the amount of pitch sweep.</b> DOWN makes the pitch sweep down. UP makes it sweep up. The higher the value, the more the pitch sweeps up or down.
 C knob	Tune	-1200 - 1200(cent)	Adjust the OSC tuning.
 D knob	Sweep Curve	-63 - 63	<b>Adjust the curve of the pitch sweep.</b> Negative values create a LOG curve. Positive values create an EXP curve.
 D (Push)	Retrigger	ON, OFF	When ON, the Wavetable is re-scanned each time a note is played.
 Auxiliary right button	Structure select	Open the structure select page.	

# SND (Sound) page – Structure edit –

---

## Change the structure

- 1 Press  Auxiliary right button on the Structure edit page.
- 2 Press D-pad to select the structure and the  button to confirm it.

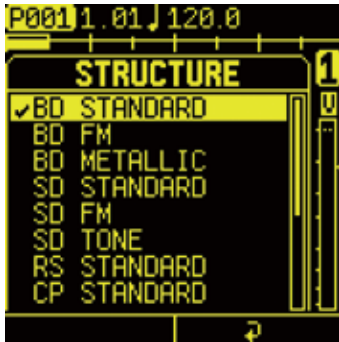



- When you change the structure, any edits on the OSC page, SND page, and AMP-ENV page will be lost.  
If you want to keep the edited state, save the pattern or sound patch before changing the structure.
  - CH, OH, and CY structures can only be selected on tracks 6 to 8.
-

# SND (Sound) page – Sound patch search –

Sound patch search allows you to quickly find the sound patch in the sound category you want from the large library of patches.

## Enter to SOUND PATCH SEARCH

- 1 On the SND page, push the  knob. SOUND PATCH SEARCH opens.

It can also be opened by pressing  +  Auxiliary right button on the OSC page.

## SOUND PATCH SEARCH operation



### D-Pad buttons

Press the up or down button to preview a sound patch.

Press the left button to play it again.

Press the right button to play it at maximum velocity (127).

### Page left switch

Holding it and pressing one of the 15 PADS will exclude sound patches with those Tags from the search.

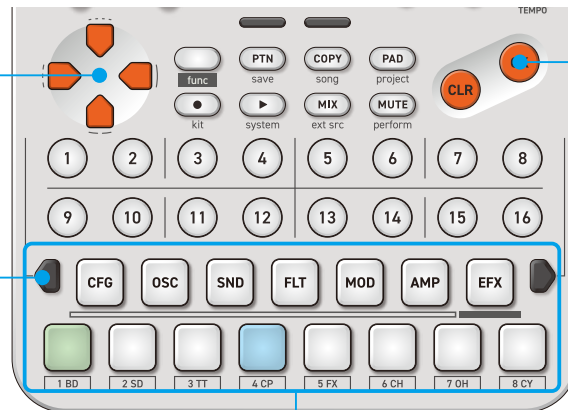

### OK button

This loads the sound patch.

### OFF (no pads lit)

All sound patches are shown except samples without Tags (sound patches without Tags can be shown by pushing the D knob).









### ON (pads lit blue)

Sound patches with Tags are shown. By pressing multiple pads, you can narrow down the target sound patches.













### Minus ON (lit yellow)

You can exclude sound patches with specific Tags by pressing a pad while holding down the page left switch.

# SND (Sound) page – Sound patch search –

SOUND PATCH SEARCH		
	Select a sound patch	
	Exit SOUND PATCH SEARCH	
D-pad	Move cursor	
 B (Push)	SND PATCH	Switch to TAG EDIT mode
	TAG EDIT MODE	<b>SAVE TAG</b> Finish TAG EDIT mode
 C (Push)	Show only the (none) slots	
 D (Push)	Show sound patches that do not have set tags	
 Auxiliary left button	 Back to SND page	
 Auxiliary right button	<b>MENU</b> Open the MENU	
<input type="checkbox"/> 15 PADs	Turn on/off tags shown	
<input type="checkbox"/> Page left switch + <input type="checkbox"/> 15 PADs	<b>Minus search</b> Turn on/off the tags not shown.	

# SND (Sound) page – Sound patch search –

TAG		
	BD	Bass Drum
	SD	Snare Drum
	TT	TomTom
	CP	Clap
	FX	FX
	CH	Closed Hi Hats
	OH	Open Hi Hats
	CY	Cymbal
	RS	Rim Shot
	PC	Percussion
	BS	Bass Synth
	SY	Synth
	NS	Noise
	TR	Traditional
	∞	New
<input type="checkbox"/> Page Fwd Switch	☆	Favorite





## SOUND PATCH SEARCH operation

SND PATCH MENU	
LOAD	Load the selected sound patch to the track.
SAVE	Save the current track sound setting to the selected slot. If a sound patch already exists there, it will be overwritten.
RENAME	Rename the selected sound patch
DELETE	Delete the selected sound patch
IMPORT	Import a sound patch in the Contents folder of the External storage card to the selected slot. If a sound patch already exists there, it will be overwritten.
EXPORT	Export a sound patch to the Contents folder of the External storage card.

## Tagging sound patches

CyDrums can set 15 tags to sound patches.

By setting tags, you can quickly access the sound patches you want to use.

- 1** Push the  knob to enter TAG EDIT mode.
- 2** Select a sound patch and press one or more of the  15PADs to add tags.  
Pads of the selected tags are lit green (except for Favorites)
- 3** Push the  knob to save the tags.  
To cancel the tagging, press the  button.



- Tags information is stored in the sound patch data.
-

# FLT (Filter) page





The FLT (Filter) page is used to set a filter on the track.

Press the  pad to open the FLT page.

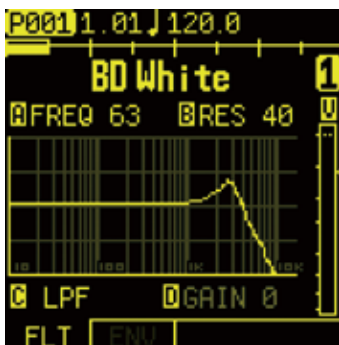
Press the  Auxiliary buttons as necessary to open the desired parameter page for editing.

## Editing the filter







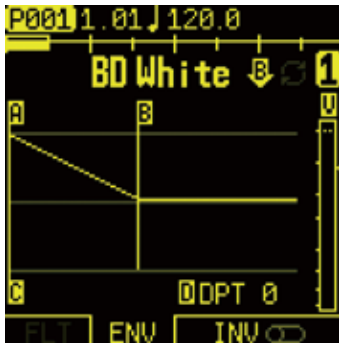

FILTER		
 A knob	FREQ	<b>0 - 127:</b> Frequency setting
 B knob	TYPE	<b>OFF, LPF, HPF, BPF, LSF, HSF, PEQ:</b> Filter type selection
 C knob	RESONANCE (BPF:BAND WIDTH)	<b>0 - 127:</b> Filter resonance If BPF is selected, this will be bandwidth.
 D knob	GAIN (unavailable for LPF, HPF, BPF)	<b>-63 - 0 - 63:</b> Amount of LSF, HSF, PEQ Gain

# FLT (Filter) page

## Adjusting filter envelopes



FLTR ENV		
 A knob	EG Attack	<b>0 - 127:</b> Envelope attack setting
 B knob	EG Release	<b>0 - 127:</b> Envelope release setting
 B (Push)	Loop ON/OFF	<b>OFF, ON:</b> Enable the loop function of the filter envelope. When set to ON, the filter envelope will be looped.
 C knob	EG Delay	<b>0 - 127:</b> Time until filter envelope starts
 D knob	EG Depth	<b>0 - 127:</b> Envelope modulation depth
 Auxiliary right button	EG Invert	<b>OFF, ON:</b> Envelope inversion

# MOD (Modulation) page







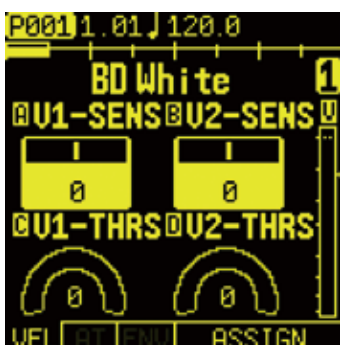

Each track has 2 Velocity sens (sensitive) modulators, 2 Aftertouch modulators, and 1 MOD ENV (modulation envelope) that can be assigned to different targets.

Press the  pad to open the MOD page.

Press the  Auxiliary buttons as necessary to open the desired parameter page for editing.

## Editing the velocity modulation









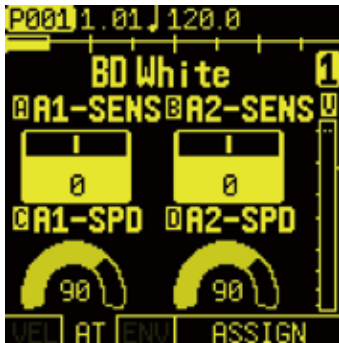

VELOCITY		
 A knob	V1-SENS	<b>-63 - 0 - +64:</b> The depth of the modulation.
 B knob	V2-SENS	<b>0 - 127:</b> The depth of the modulation.
 C knob	V1-THRESHOLD	<b>0 - 127:</b> The threshold of pressure at which modulation is applied.
 D knob	V2-THRESHOLD	<b>0 - 127:</b> The threshold of pressure at which modulation is applied.
 Auxiliary right button	ASSIGN	Select the modulation target Use the  A/C knob to select V1, the  B/D knob to select V2 parameters, then press the  button to confirm. See the modulation target list (→ P.65)

# MOD (Modulation) page

## Editing the Aftertouch modulation



AFTER TOUCH		
 A knob	A1-SENS	<b>-63 - 0 - +64:</b> The depth of the modulation.
 B knob	A2-SENS	<b>0 - 127:</b> The depth of the modulation.
 C knob	A1-SPD	<b>0 - 127:</b> The speed of the fluctuation that follows the pressure value.
 D knob	A2-SPD	<b>0 - 127:</b> The speed of the fluctuation that follows the pressure value.
 Auxiliary right button	ASSIGN	Select the modulation target Use the  A/C knob to select A1, the  B/D knob to select A2 parameters, then press the  button to confirm. See the modulation target list (→ P.65)

# MOD (Modulation) page

## Adjusting modulation envelope

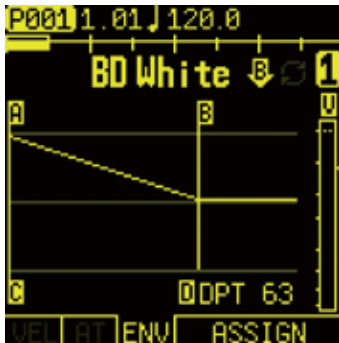

MOD ENVELOPE		
A knob	EG Attack	<b>0 - 127:</b> Envelope attack setting
B knob	EG Decay	<b>0 - 127:</b> Envelope decay setting
B (Push)	Loop ON/OFF	<b>ON, OFF:</b> Enable the loop function of the modulation envelope. When set to ON, the modulation envelope will be looped.
C knob	EG Delay	<b>0 - 127:</b> Time until the envelope starts
D knob	EG Depth	<b>-63 - 0 - 63:</b> Envelope modulation depth
Auxiliary right button	ASSIGN	Select the modulation target Use either knob to select a parameter and press the  button to confirm.

# MOD (Modulation) page

## The parameters assignable as the modulation target

ASSIGN		
ASSIGN	Description	Parameter page location
OFF	None	
O1 WAVE	OSC1 WaveType	OSC page
O1 DIR	OSC1 Direction	OSC page
O1 SPEED	OSC1 Speed	OSC page
O1 START	OSC1 Start position	OSC page
O1 END	OSC1 End position	OSC page
O1 CURV	OSC1 Curve	OSC page
O2 WAVE	OSC2 WaveType	OSC page
O2 DIR	OSC2 Direction	OSC page
O2 SPEED	OSC2 Speed	OSC page
O2 START	OSC2 Start position	OSC page
O2 END	OSC2 End position	OSC page
O2 CURV	OSC2 Curve	OSC page
NS LVL	Noise Level	OSC page
NS DCY	Noise Decay	OSC page
NS TONE	Noise Tone	SND page
NS LP-F	Noise LPF Cutoff	SND page
NS LP-Q	Noise LPF Reso	SND page
NS RES F	Noise Reso Freq	OSC page
TCK LVL	Tick Level	OSC page
TCK TIME	Tick Time	OSC page
TUNE	Tune	SND page
RETRIGGER	Retrigger	SND page
RATIO	Ratio	SND page
OSC LVL	OSC Level	SND page

# MOD (Modulation) page

ASSIGN		
ASSIGN	Description	Parameter page location
BELL	Bell	SND page
BALANCE	Balance	SND page
TAIL	Env Tail	SND page
SND HP-F	HPF Cutoff	SND page
SND LP-Q	LPF Resonance	SND page
SND LP-F	LPF Cutoff	SND page
METALLIC	Metallic	SND page
TONE	Tone	SND page
OSC DCY	OSC Decay	SND page
SW1 DPTH	Sweep1 Depth	SND page
SW1 TIME	Sweep1 Time	SND page
SW1 CURV	Sweep1 Curve	SND page
SW2 DPTH	Sweep2 Depth	SND page
SW2 TIME	Sweep2 Time	SND page
CP RATE	Clap Rate	SND page (CP STD)
CP NUM	Clap Number	SND page (CP STD)
CP RAND	Clap Random	SND page (CP STD)
CP TAIL	Clap Tail	SND page (CP STD)
CP ATK	Clap Attack	SND page (CP STD)
FLT FREQ	Filter Frequency	FLT page
FLT RESO	Filter Resonance	FLT page
FLT GAIN	Filter Gain	FLT page
FENV DPT	Filter EG Depth	FLT page
FENV DLY	Filter EG Delay	FLT page
FENV ATK	Filter EG Attack	FLT page
FENV DCY	Filter EG Decay	FLT page
MENV ATK	Mod Env Attack	MOD page

# MOD (Modulation) page

---

ASSIGN		
ASSIGN	Description	Parameter page location
MENV DCY	Mod Env Decay	MOD page
MENV DPT	Mod Env Depth	MOD page
MENV DLY	Mod Env Delay	MOD page
AMP VOL	Amp Level	AMP page
AMP PAN	Amp Pan	AMP page
AMP ATK	Amp Attack	AMP page
AMP DCY	Amp Decay	AMP page
AMP D->R	Amp Decay to Release level	AMP page
AMP REL	Amp Release	AMP page
AMP CURV	Amp Curve	AMP page
AMP DIST	Amp Distortion	AMP page
SEND RVB	Amp Reverb Send	AMP page
SEND SCC	Amp Send Sidechain Comp	AMP page
V1-SENS	Mod Velocity1 Sense	MOD page
V2-SENS	Mod Velocity2 Sense	MOD page
A1-SENS	Mod Aftertouch1 Sense	MOD page
A2-SENS	Mod Aftertouch2 Sense	MOD page

# AMP page





The AMP page is used to set amp envelope on the track.

Press the  Pad to open the AMP page.

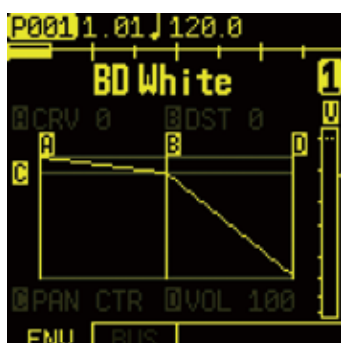
Press the  Auxiliary left button to open the desired parameter page for editing.

## Editing envelope, panning and volume



AMP		
 A knob	EG Attack	<b>0 - 127:</b> Envelope attack setting. Sets the time it takes to reach the volume setting when a note is played.
 B knob	EG Decay	<b>0 - 127:</b> Envelope decay setting. Sets the decay rate of volume after the attack stage. When the EG D → R parameter (see below) is set to 127, This controls the sustain time instead of decay rate.
 C knob	EG D → R	<b>0 - 127:</b> Envelope decay level. When the volume level reaches the decay level, the envelope shifts to the release stage.
 D knob	EG Release	<b>0 - 127:</b> Envelope release setting. Sets the time until the volume goes to 0 after the release stage is entered.

# AMP page

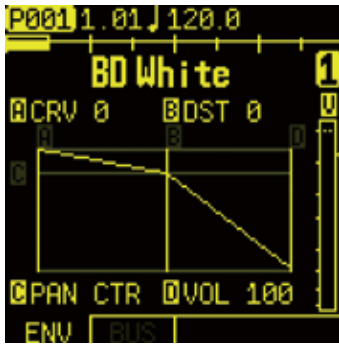

AMP		
<p>⬇ A (Push)</p>	Curve	<p><b>-10 - 10:</b> Curve of the Amp envelope. A negative value will create a downwards curve, a positive value will create an upwards curve. A value of 0 will create a linear curve.</p>
<p>⬇ B (Push)</p>	Distortion	<p><b>0 - 127:</b> Amp distortion This adds an overtone to the sound with distortion.</p>
<p>⬇ C (Push)</p>	PAN	<p><b>L63 - CTR - R63:</b> Track panning adjustment</p>
<p>⬇ D (Push)</p>	Volume	<p><b>0 - 127:</b> Track volume adjustment Sets the maximum volume of the Amp envelope.</p>

# AMP page

## Editing the output BUS routing, reverb send and side chain send setting

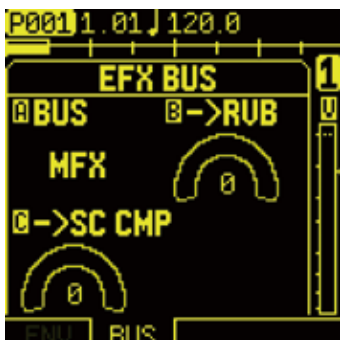



BUS		
A knob	BUS	<b>DIRECT, MFX, EFX1, EFX2:</b> Switch the output bus of the track.
B knob	→ RVB	<b>0 - 127:</b> Adjust the amount of sound signal sent to the reverb. It is only enabled when MFX is selected on the BUS.
C knob	→ SC COMP	<b>0 - 127:</b> Adjust the amount of signal sent to the Sidechain Comp trigger.
Auxiliary left button	ENV/BUS	Switch which page tab is shown.

# AMP page

---

## Selecting track output BUS





- 1 Press the  pad to open the AMP page.
- 2 Press the  Auxiliary left button **ENV/BUS** to open the BUS page.
- 3 Turn  A knob to select the output BUS.

BUS	
Direct	The signal does not go through any effect and outputs directly from the mixer.
MFX	The signal outputs to the MFX BUS. The amount of signal sent to the reverb can be adjusted by → RVB.
EFX1	The signal outputs to EFX1 BUS.
EFX2	The signal outputs to EFX2 BUS.

# AMP page

---



## Setting the send signal amount to the Reverb

- 1 Press the  pad to open the AMP page.
- 2 Press the  Auxiliary left buttons **ENV/BUS** to open the BUS page.
- 3 Turn  A knob to select the output MFX.
- 4 Turn  B knob to adjust the amount of send signal to the reverb.



- If a BUS other than MFX is selected, you cannot send signal to the reverb.
  - The procedures above are only applicable when the effect routing setting (→ P.75) is set to configuration 1, 3, or 5.
- 

## Setting the Sidechain Compressor Trigger Signal

- 1 Press the  pad to open the AMP page.
- 2 Press the  Auxiliary left buttons **ENV/BUS** to open the BUS page.
- 3 Turn  C knob to adjust the amount of send signal to the SC COMP trigger.



- This is only applicable when the MFX setting (→ P.79) is set to SC COMP.
-

# EFX (Effect) page





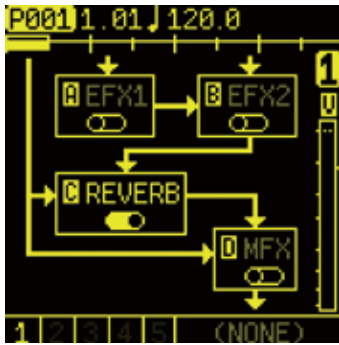

The EFX page is used to configure the effect settings.

Press the  pad to open the EFX page.

Press the Auxiliary buttons as necessary to open the desired parameter page for editing.

The signal path can be flexibly changed by selecting between the different EFX BUS routings.



EFX		
 A knob	EFX1 On/Off	<b>On, Off:</b> Switch the EFX1 ON/OFF.
 B knob	EFX2 On/Off	<b>On, Off:</b> Switch the EFX2 ON/OFF.
 C knob	Reverb On/Off	<b>On, Off:</b> Switch the Reverb ON/OFF.
 D knob	MFX On/Off	<b>On, Off:</b> Switch the MFX ON/OFF.
 Auxiliary left button	Routing	<b>1, 2, 3, 4, 5:</b> Select the EFX BUS insert position and routing.
 Auxiliary right button	EFX patch	The currently selected EFX patch is displayed here. Press the button to open the EFX PATCH SELECT menu. (→ P.83)



- Press the  A - D knobs to open the EFX edit page that corresponds to each knob.

# EFX (Effect) page

## Effect routing

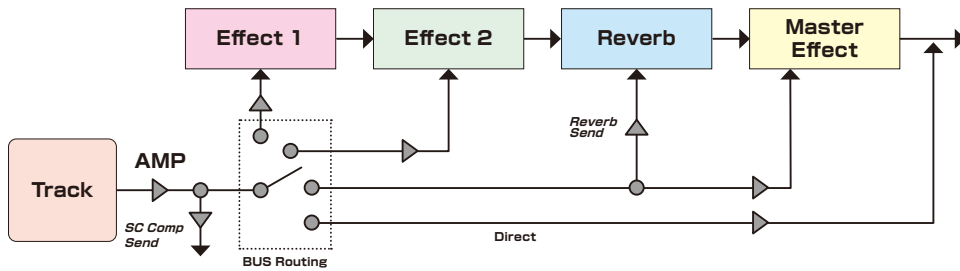

### Routing Type1

All effect are connected in a series.

The Master FX is also applied to the wet sound of the Reverb.

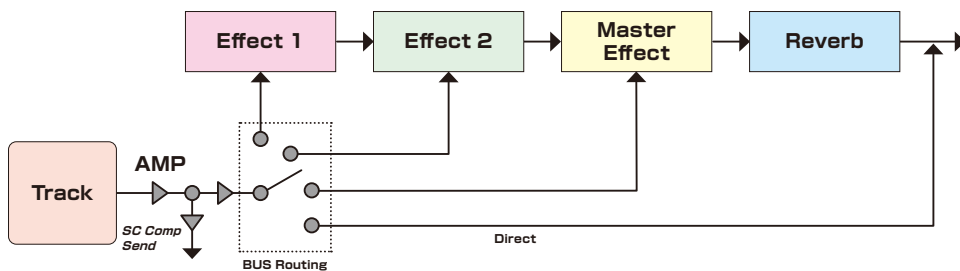

### Routing Type2

All effect are connected in a series.

The Master FX is not applied to the wet sound of the Reverb.

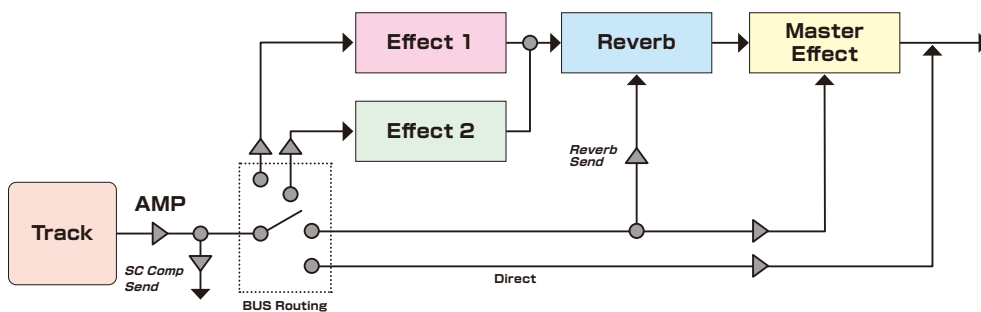

### Routing Type3

EFX1 and EFX2 are connected in a parallel manner.

The Master FX is also applied to the wet sound of the Reverb.

# EFX (Effect) page

## Effect routing

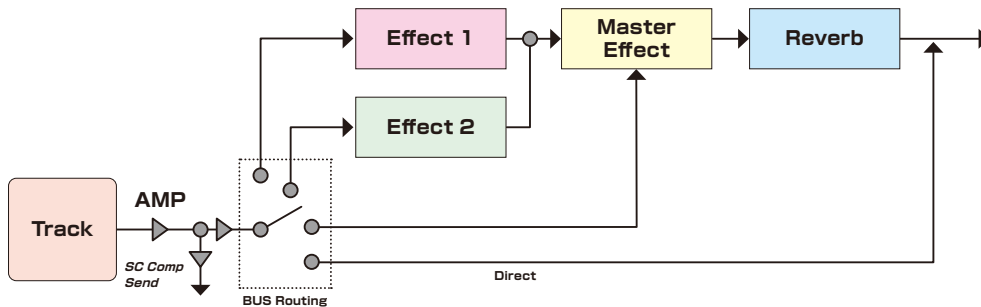

### Routing Type4

EFX1 and EFX2 are connected in a parallel manner.

The Master FX is not applied to the wet sound of the Reverb.

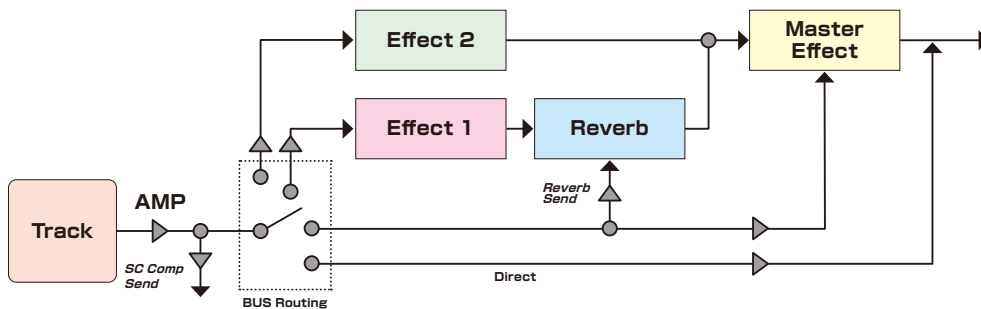

### Routing Type5

EFX1 and EFX2 are connected in a parallel manner.

The EFX2 bus is not connected to the Reverb.

The Master FX is also applied to the wet sound of the Reverb.

# EFX (Effect) page





---

The CyDums can have up to 2 insert effect buses, and each bus can be set to a different type of effect.

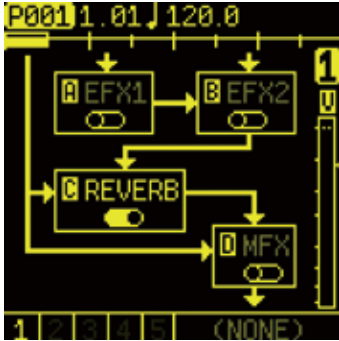
## Setting the effect

- 1 Press  PAD to open the EFX page.



- 2 Turn the  A knob or  B knob to activate the EFX1/EFX2.
- 3 Press the  A knob or  B knob to open the EFX1/EFX2 edit page.



- 4 Press  Auxiliary right button **TYPE**.



- 5 Select an effect to use and press the  button.

# EFX (Effect) page

EFX TYPE				
EFX TYPE	A KNOB	B KNOB	C KNOB	D KNOB
CHORUS	RATE	DEPTH		MIX
FLANGER	RATE	DEPTH	FEEDBACK	MIX
PHASER	RATE	STAGE	INVERT	MIX
INDELAY	TIME	FEEDBACK	BPM SYNC	BALANCE
VIBRATO	RATE	DEPTH	BPM SYNC	
AUTO WAH	TYPE	SENS	DEPTH	Q
TREMOLO	RATE	DEPTH	BPM SYNC	
RING MOD	TYPE	RATE	DEPTH	MIX
DETUNE	RATE	DEPTH		MIX
OVER DRIVE	GAIN	TONE		LEVEL
CRUSHER	SAMPLE RATE	BIT RATE	CUTOFF	BALANCE
LO & HI EQ	LOW-FREQ	HIGH-FREQ	LOW-GAIN	HIGH-GAIN
LPF	CUTOFF	RESO		
HPF	CUTOFF	RESO		
BPF	CUTOFF	RESO		
ISOLATOR	CUTOFF	BALANCE		
TILT FILTER	CUTOFF	BALANCE		
VINYL NOISE	CUTOFF FREQ	CUTOFF LEVEL	NOISE LEVEL	
WOW & FLUTTER	WOW	FLUTTER		
S. MAXIMIZER	GAIN	FREQ		LEVEL
STOMP COMP	SENS	ATTACK		LEVEL
RACKCOMP	ATTACK	RELEASE	RATIO	THRESHOLD

# EFX (Effect) page





## Editing the reverb

The CyDrums is equipped with a stereo reverb effect. When the EFX routing is set to 1, 3, or 5 and the BUS setting is set to MFX, the reverb send amount for each track can be adjusted on the AMP page.

Press the  PAD to open the EFX page.

Press the  C knob to open the Reverb edit page.



REVERB		
 B knob	DECAY	<b>0 - 127:</b> Adjust the decay time.
 C knob	LO CUT	<b>0 - 127:</b> Adjust the Lo cut filter frequency. The higher the value, the higher the cutoff frequency is set.
 D knob	HI DAMP	<b>0 - 127:</b> Adjust the amount of attenuation of high frequencies. The higher the value, the more the high frequencies are attenuated.
 Auxiliary right button	MUTE: PRE/ POST	Switch the mute position of the reverb signal.  <b>MUTE: PRE</b> This mutes the input signal to the Reverb.  <b>MUTE: POST</b> This mutes the output signal from the Reverb.

# EFX (Effect) page

---

## Editing the Master FX

CyDrums has one Master FX.

You can use the filter or compressors to shape the overall sound of the CyDrums, or use Remix and Snip Loop for performance effects.

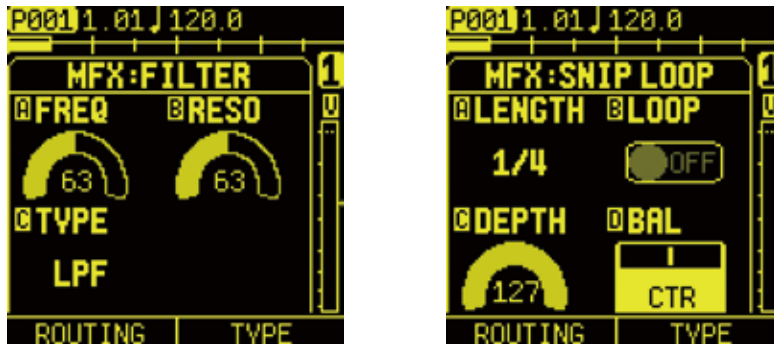

- 1 Press **EFX** PAD to open the EFX page.
- 2 Turn the **⊕D** knob to activate the MFX.
- 3 Press the **⊕D** knob to open the MFX edit page.
- 4 Press **⏏** Auxiliary right button **TYPE**.
- 5 Select an effect to use and press **OK** button.

# EFX (Effect) page

FILTER		
ⓐ knob	TYPE	<b>LPF, HPF, BPF:</b> Filter type selection
ⓒ knob	FREQ	<b>0 - 127:</b> Filter cutoff frequency
ⓓ knob	RESONANCE	<b>0 - 127:</b> Filter resonance
COMP & SC COMP		
ⓐ knob	RATIO	<b>0 - 127:</b> Compressor ratio value
ⓑ knob	THRESHOLD	<b>0 - 127:</b> Compressor threshold value
ⓒ knob	ATTACK	<b>0 - 127:</b> Compressor attack time
ⓓ knob	RELEASE	<b>0 - 127:</b> Compressor release time



- On the MFX edit page, press **OK** button to switch the MFX ON/OFF.

REMIX		
ⓐ knob	REPEAT	<b>0 - 127:</b> Set speed of repeats
ⓒ knob	ENABLE	<b>OFF, ON:</b> Set to ON to activate the Remix effect. It can also be switched ON/OFF by pressing <b>OK</b> button.

# EFX (Effect) page

SNIP LOOP		
ⓂA knob	LENGTH	<p><b>1/1, 1/2, 1/4, 1/8, 1/12, 1/16, 1/24, 1/32, 1/48, 1/64, 1/128:</b></p> <p>Snip the loop audio by the selected length.</p> <p>The LENGTH can also be changed to multiples of 1/4 - 1/32 by pressing the D-Pad.</p>
ⓂB knob	LOOP	<p><b>OFF, ON:</b></p> <p>Once turned ON, 1 bar of the playback audio will be recorded, and it will be looped by snipping the selected LENGTH. It can also be switched ON/OFF by pressing  button</p>
ⓂC knob	DEPTH	<p><b>0 - 127:</b></p> <p>Adjust the amount of audio that will be looped back within the selected LENGTH.</p>
ⓂD knob	BAL	<p><b>D63 - CTR - W63:</b></p> <p>Adjust the mix amount between the playback audio and loop audio.</p>

# Select the EFX patch

By selecting an EFX patch, you can quickly apply the effect settings you want to use in a pattern.

Patterns that have the same EFX patch selected will share the same parameter settings.

This means that if you change between patterns with the same EFX patch, the parameters will switch smoothly without being reset.

- 1 Press  Auxiliary right button right **PATCH** on EFX routing page.

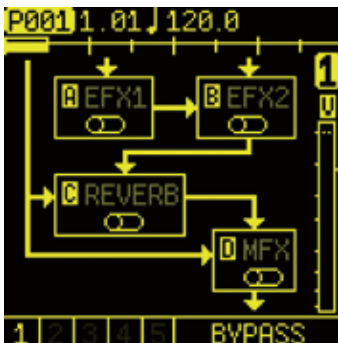

- 2 Press  STEP.  
This selects a EFX patch.  
(STEP 1 for EFX patch 1... STEP 16 for EFX patch 16)

- 3 Press the  button to confirm a EFX patch.



## Selecting EFX patch 17 and higher

Press Page switches or  TRACK PAD after procedure 1 to move to the next 16 patches, enabling the selection of patch 17 and higher.

Press  or  pad to switch between BANK A and B.

# Managing EFX patch

## Basic operation in EFX PATCH SELECT

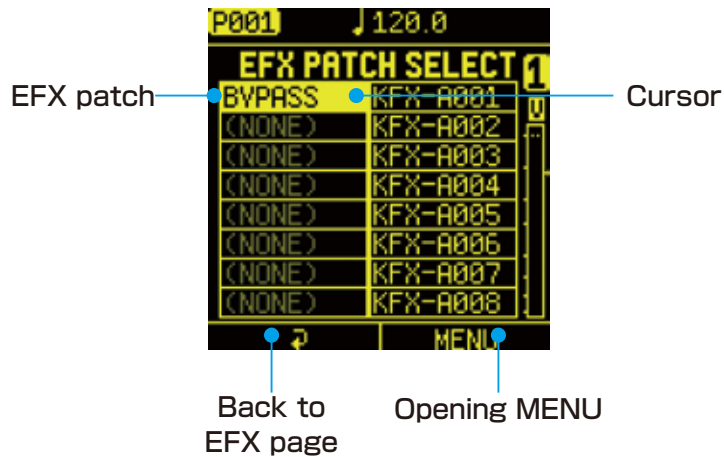





- 1 Press  Auxiliary right button **EFX PATCH**.

EFX PATCH SELECT MENU	
SELECT	Select the EFX patch to current pattern.
SAVE	Save the status of the current EFX settings to the selected slot as an EFX patch.
RENAME	Rename selected EFX patch.
IMPORT	Import an EFX patch from the Contents folder of the External storage card to the selected slot.
DELETE	Delete selected EFX patch
EXPORT	Export an EFX patch to the Contents folder of the External storage card.

# Managing EFX patch

---

## Storing edited EFX setting as EFX patch

- 1** Press  STEP.  
This selects a slot to store.  
(STEP 1 for EFX patch 1... STEP 16 for EFX patch 16)
- 2** Press  Auxiliary right button **MENU** to open MENU.
- 3** Turn the  knob to select SAVE and press  button.







- If you want to save the EFX patch as a new patch without overwriting an old patch, select one of the empty slots, denoted with the word "(NONE)", as your save location.
  - When overwriting an EFX patch, the changes will be applied to all patterns and drum kits that use the overwritten patch.
  - Up to 256 EFX patches can be stored.
-



# EFX (Effect) page

---

## Import a EFX patch

- 1** Press STEP.  
This selects a slot to import.  
(STEP 1 for EFX patch 1... STEP 16 for EFX patch 16)
- 2** Press Auxiliary right button **MENU** to open MENU.
- 3** Turn knob to select IMPORT and Press  button.
- 4** Select the EFX patch to import and press  button.

## Export a EFX patch

- 1** Press STEP.  
This selects a EFX patch to export.  
(STEP 1 for EFX patch 1... STEP 16 for EFX patch 16)
- 2** Press Auxiliary right button **MENU** to open MENU.
- 3** Select the EFX patch to export.
- 4** Turn knob to select IMPORT and Press  button.

# Creating Patterns / Step Sequencer Overview

---

## Overview

The CyDrums step sequencer can play multiple steps in order (a sequence) with performance and parameter data.



Steps contain note data and parameter data.

Sequences contain multiple steps.



Sequences play in order from the first step.

A pattern is a combination of 8track sequencers. With lengths of 1-128 steps, patterns can be used as the smallest units in making songs.

## CyDrums step sequencer features

The sequencer in the CyDrums has the following features.

### Three input methods

#### Step recording

Record notes to each step with the sequencer stopped

#### Real-time recording

Record notes to steps by playing the keyboard

#### Direct recording

Record notes to steps directly during sequencer playback

# Step Sequencer Overview

---





## Flexible sequencing

### Sequences with up to 128 steps

The number of steps can be set from 1 - 128 as desired for each track

### Support for various note lengths

The length of each step can be set from 1/64th note to 1 bar

 (lit orange)	Note
 (lit yellow-green)	Parameter Lock
 (lit yellow)	Note and Parameter Lock
 (lit pale orange)	Tied note (Indicated when REC is on)







- Sequencer settings can be changed on the CFG page.  
CFG page details ( → P.40)
-





# Creating Sequences – Step recording

Using step recording, sequences can be created carefully while playback is stopped.

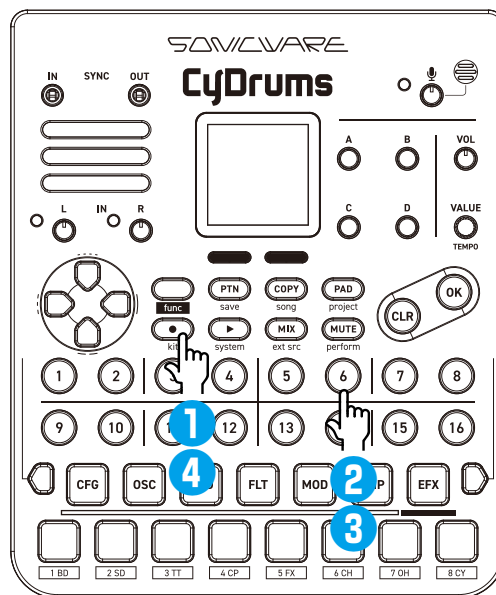
## Basic operations

- 1 When playback is stopped press  (lights red).
- 2 Press the  STEP for the position where you want to input a note for the currently selected TRACK.  
The input STEP will light orange.  
Press the same  STEP again to clear it.
- 3 Repeat procedure 2 to create the sequence.
- 4 Press  to end step recording.



- In PAD mode, the selected  STEP blinks green, and pressing the  15 PADS will input a note to the step.  
When a note is entered, the  STEP changes to blinking green and orange.
- In PAD mode, you can delete notes by pressing  CLR +  STEP.

# Creating Sequences – Step recording

---

## Selecting steps 17 and higher

After procedure 1, press the page switch to select steps 17 and higher.





While pressing the page switch, pressing a  TRACK PAD that is lit blue will also select the corresponding page.











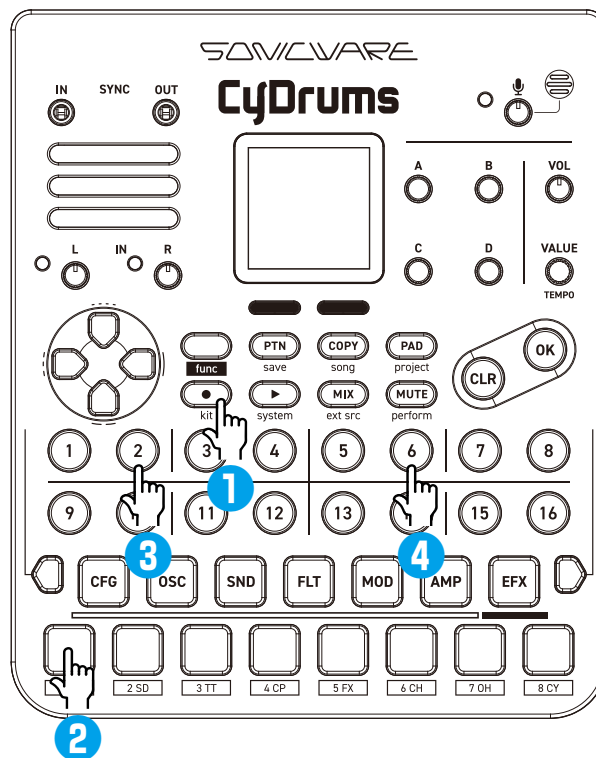

- The page switch is enabled/disabled according to the LEN (length) setting on the CFG page. (→ P.40)
-

# Creating Sequences – Step recording

## Inputting tied-notes (long sounds)

- 1 Press  while playback is stopped to start step recording (button lit red).
- 2 Press and hold a  TRACK PAD.
- 3 Press and hold the  STEP at the position where you want to start inputting notes.
- 4 Press the  STEP where you want the note to end. Tied notes are entered from the start step to the end step.





- When  is lit red, the  STEPs are lit pale orange to indicate the tied notes. When  is off, they are indicated by pressing  + the  STEP of the note.
- In PAD mode, the selected  STEP blinks green, and pressing one of the  15 PADS will input a note to the step. When a note is entered, the  STEP changes to lit orange, and the end step of the tied note blinks green and pale orange.
- In PAD mode, you can delete notes by pressing  + .





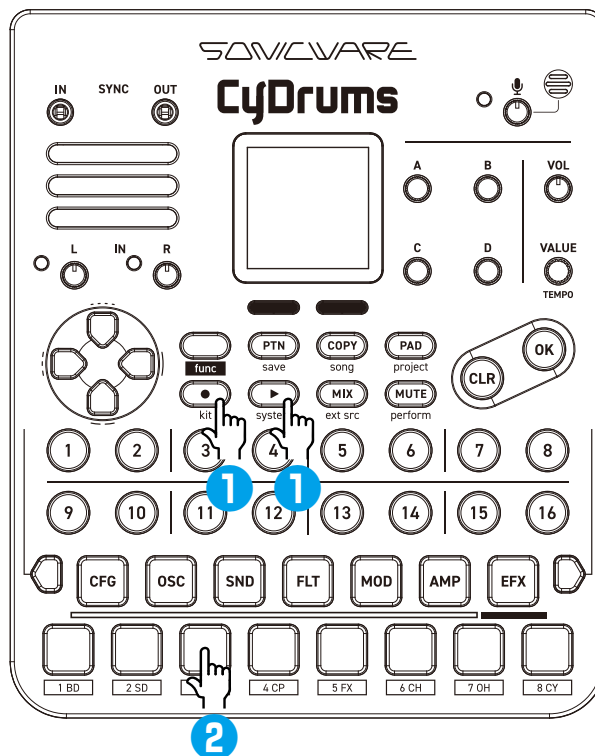

# Creating Sequences – Real-time recording

Sequences can be created in real time while playing the  15 PADs.

## Basic operations

- 1 After pressing , press .
- 2 The pattern will start playing. Press the  TRACK PAD when you want to input them.



- If you want to start over again during real-time recording, press  +  TRACK PAD to easily clear the notes you have recorded. In PAD mode, press  +  +  TRACK PAD to clear the notes.
- If you want to clear only the note of a specific step, press  + the .

# Creating Sequences – Direct recording

With direct recording, notes can be input on steps directly when both stopped and playing back.

This is particularly useful for building up sequences while performing by directly inputting notes during playback.

## Basic operations

- 1 While pressing a  TRACK PAD, press the  STEP at the desired position to input a note.

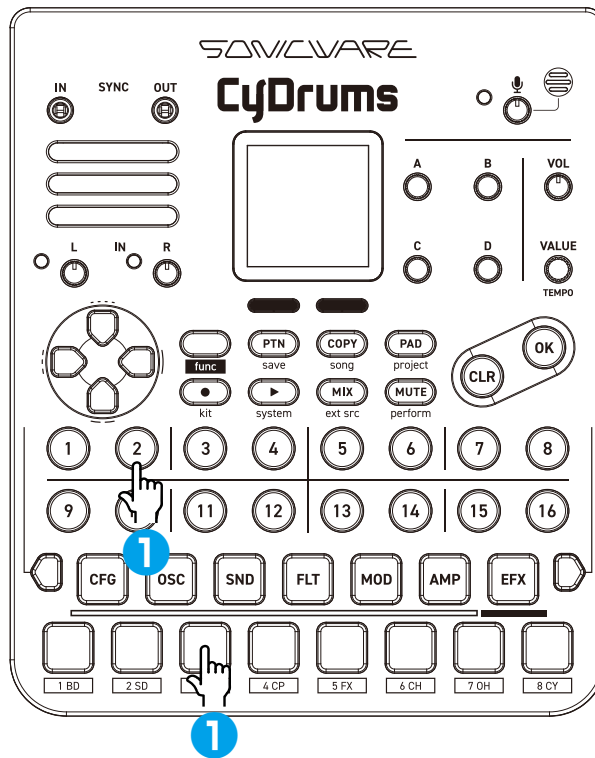

# Creating Sequences – Clear note –



---

## Clearing a note

- 1 While holding down , press the STEP you want to clear.

## Clearing tied notes

- 1 Press  (lit red)

- 2 Hold  and press the STEP at the position you want to clear.  
This clears all consecutive tied notes from the step you pressed to the end of the tied notes.  
Pressing the start step clears all of the tied notes.

# Parameter Locking

---

The CyDrums has a parameter locking function that can record knob operations to steps.

This allows sound to be changed over time and is useful for creating patterns with great expressiveness.

Parameter locking data can be input in the following three ways.

## Direct input

Turning knobs while pressing ●STEP is the fundamental method of direct input.

## Real-time input

Record the operation of knobs during playback in real-time in this method.

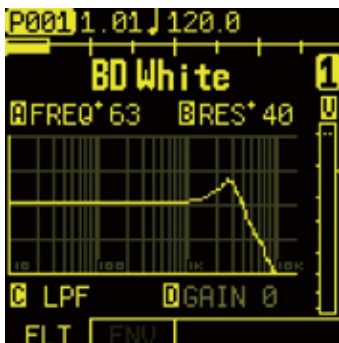

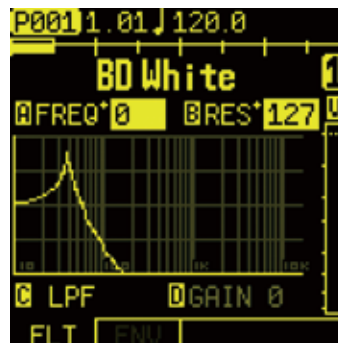

Parameters that are parameter locked are indicated by + marks.



While a ●STEP is pressed, the locked parameters are highlighted.

# Parameter Locking – Direct input

## Using direct input

- 1 Press a  PARAMETER PAD to open the page where you want to record parameter locking.
- 2 While pressing a  STEP, turn the  A - D knobs.

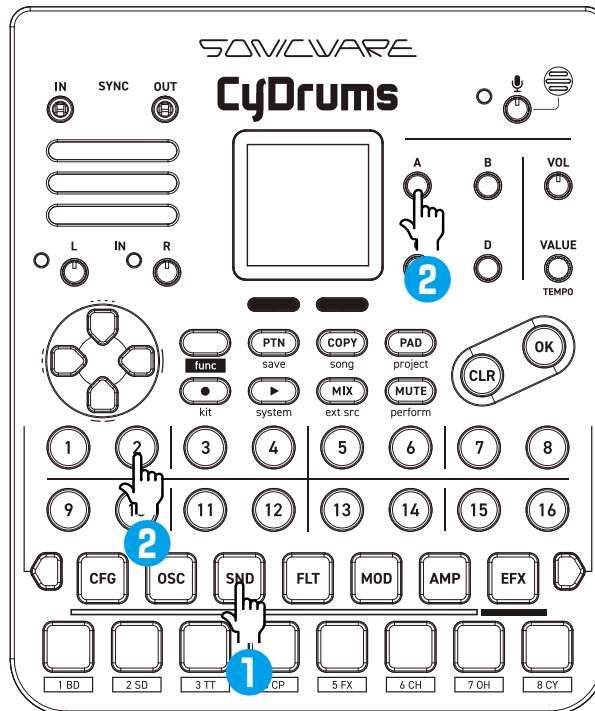

# Parameter Locking – Direct input

---

## Clearing parameter lock information

- 1 Press **CLR** + **STEP** (lit green) for which parameter lock has been input.



- **STEP**s to which both **NOTE** and parameter lock information are input are lit yellow.

If you only want to delete the parameter lock data, you can press **func** + **STEP** and delete it from the **STEP DATA** menu.

For details on the **STEP DATA** menu ( → P.98)





---

## Clearing all locking for any parameter at once



- 1 While holding down **CLR**, press the **A - D** knob for the parameter with locking you want to clear. All applicable parameter lock information for the track will be cleared.

# Parameter Locking – Real-time input

## Inputting in real time (parameter recording)

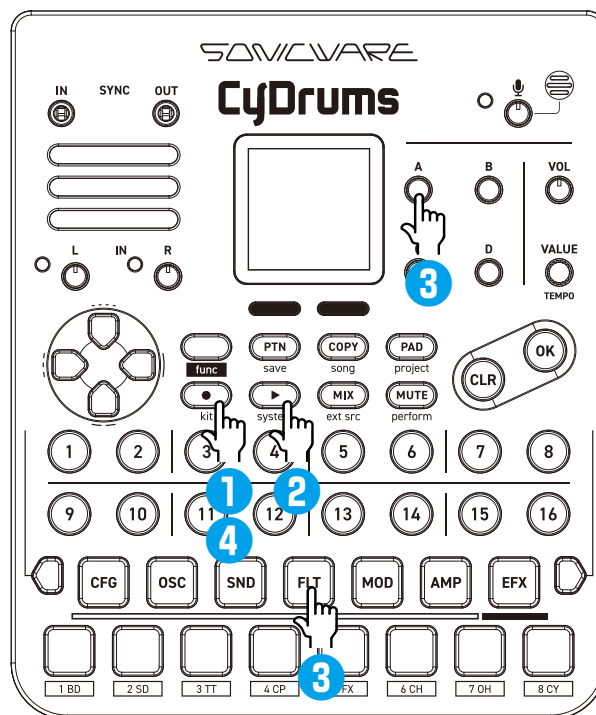
- 1 Press  (lights red).
- 2 Press  to play the pattern.
- 3 Press the  pad for the parameters you want to record.
- 4 And use the  A - D knobs to record them.
- 5 Press  to end real-time input.



- Notes and parameter lock data on a track can be cleared all at once by pressing  +  TRACK PAD at the same time.

# Editing Sequences

Steps that have notes, parameter locks and other data already input can be selected and edited.

## Editing step data

- 1 Press the **func** button at the same time as a button for a **STEP** that already has data input to open the STEP DATA MENU.
- 2 Use the **A** knob to select the parameter to edit and turn **B** to adjust the parameter.



STEP DATA	
<b>A</b> knob	Select parameter
<b>B</b> knob	Adjust parameter
<b>C</b> knob	Adjust MICRO TIMING
Auxiliary right button	UNDO, REDO
<b>func</b> + <b>CLR</b>	Delete selected data



- UNDO/REDO can be used on the most recently adjusted parameter or deleted data.
- The direction L-R buttons can be used to change the selected step.

# Editing Sequences

---

## MICRO TIMING

The CyDrums sequencer can record/edit MICRO TIMING information (note-on timing and note-off timing).

Real-time recording data is not quantized (resolution =  $\downarrow / 72$ ), so your performance timing is saved, and can be quantized for each track or edited by each step. Nudging steps back and forth is also easy, even with beats you create using step and direct recording.

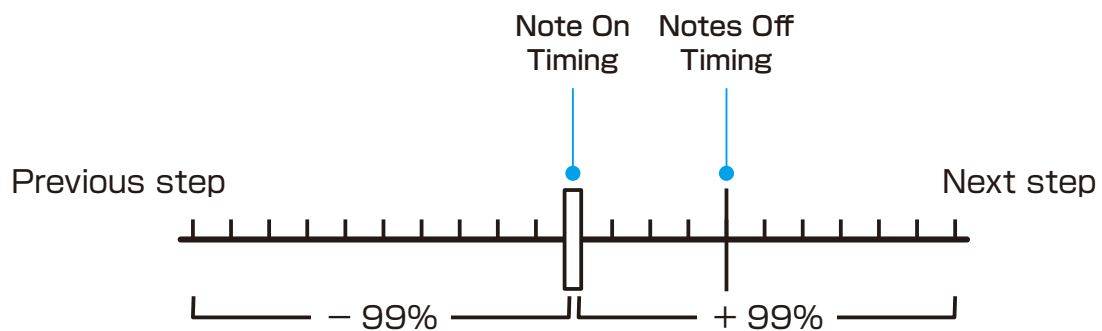

# Editing Sequences

---

## Editing Step Data

STEP DATA	
NOTE	
NOTE	Note (C-1 to G9)
VELOCITY	Velocity
MOD VELO	Modulation velocity
ROLL	Roll information
OFF TIM	Note-off timing

# Editing Sequences

<b>PARAMETER</b>			
<b>NOTE</b>			
PRESSURE			
<b>CONFIG</b>			
DICE		SWING	
<b>OSC</b>			
See Structure List ( → P.169)			
<b>SOUND</b>			
See Structure List ( → P.169)			
<b>FILTER</b>			
TYPE	FREQ	RESO	EG DPTH
EG DLY	EG ATK	EG DCY	F.GAIN
<b>MOD</b>			
V1-SENS	V1-THRS	V2-SENS	V2-THRS
A1-SENS	A1-SPD	A2-SENS	A2-SPD
ATK	DECAY	DEPTH	DELAY
<b>AMP</b>			
ATTACK	DECAY	D → R	RELEASE
CURVE	DIST	VOL	PAN
BUS	→ RVB	→ SC CMP	





- PRESSURE is enabled when real-time recording is performed with MOD AT assigned.



# Editing Sequences

---

## Clearing steps

- 1 Press the  button and the  STEP you want to clear.  
The note and parameter lock data saved to that step will be cleared.

## Clearing track data

- 1 Press the  button and the  TRACK PAD of the track with sequence data you want to clear.
- 2 Select the item to clear, and press the  button.

CLEAR TRACK DATA	
ALL	This will clear all parameter data and note sequence data from the track.
PRM	This will clear the track sound parameter data.
NOTE	This will clear all sequence data.
PRS	This will clear pressure(aftertouch) data in the sequence.
LCK	This will clear parameter locking data in the sequence.



- To return the parameter pad settings to their default values, press  + PARAMETER PAD.
-

# Copy Functions

---

## Copying track settings to another

- 1 Holding the **COPY** button (lit orange), press the PARAMETER PAD to copy the track settings from the PAD's parameter page.  
**COPY** will blink orange.
- 2 Holding the **COPY** button (lit red), press a  TRACK PAD that is blinking orange to paste the track settings.



- The currently copied content can be cleared by pressing **CLR** + **COPY**.  
Unless the copied content is cleared, it can be pasted as many times as wanted.
  - If either the OSC or SND parameters are copied, both the OSC and SND parameters will be pasted when you execute Paste.
- 

## Copying one track to another

- 1 Holding the **COPY** button (lit orange), press a  TRACK PAD to copy.  
**COPY** will blink orange.
- 2 Holding the **COPY** button (lit red), press the  TRACK PAD that is blinking orange to paste the track.





## Copying steps

- 1 Holding the **COPY** button (lit orange), press the **STEP** to copy.  
**COPY** will blink orange.
- 2 Holding the **COPY** button (lit red), press a **STEP** again to paste to that step.

# Copy Functions

---

## Copying the sequence page settings to another

- 1 Holding the  button (lit orange) and a page switch, press a  TRACK PAD (lit blue) to copy the page.  
 will blink orange.
- 2 Holding the  button (lit red) and a page switch, press a  TRACK PAD (lit blue) to paste the sequence page.



- When holding down the copy button and page switch, the currently selected page will be indicated by a  TRACK PAD that is lit white. Other pages in the sequence will be lit blue. Inactive pages will be dark.
-

# Saving and Managing Patterns

---

## Saving patterns

- 1 Press **func** + **PTN** to open PATTERN SAVE menu.
- 2 Press **STEP** to select the save destination pattern.  
( STEP1 = Pattern 1 ... STEP16 = Pattern 16)  
See "Selecting patterns" on. ( → P.19)
- 3 Press the **OK** button to save pattern.

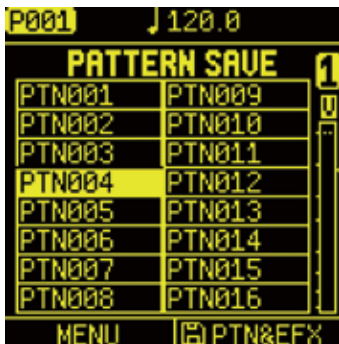

- Copying a pattern can be easily done this method.
  - Saved patterns will be lost if the project is not saved. Be sure to save the project before turning off the power.  
Saving projects ( → P.127)
  - If you have accidentally saved a pattern, you can cancel saving the pattern by reloading the project.
  - Only saving the project will not save the patterns. Be aware that they need to be saved individually.
-

# Saving and Managing Patterns

## Saving patterns with EFX patch

By pressing the  Auxiliary Right button on the PATTERN SAVE menu, you can set whether or not to save the EFX patch parameters when you execute the pattern save.

PATTERN SAVE	
PTN	Only the pattern is saved. Any EFX parameters you have set will not be saved.
PTN&EFX	Saves both the pattern and any edited EFX patch parameters.

If no EFX patch is selected for the pattern—i.e., if the EFX patch is set to "(NONE)"—the EFX PATCH SAVE screen will be displayed after you complete the steps described above.



Press  STEP to select a EFX patch to store and press  button.  
(STEP 1 for EFX patch 1... STEP 16 for EFX patch 16)



- EFX patches operate globally.

Thus, if you overwrite an EFX patch, the changes will be applied to all patterns and drum kits that use the EFX patch.

# Saving and Managing Patterns

## Clearing (initializing) patterns

- 1 Press **CLR** + **PTN**.
- 2 Select the item to clear, and press the **OK** button.



CLEAR PATTERN DATA	
ALL	Clear all parameters in the pattern.
PRM	Clear track settings.
NOTE	Clear the note information.
PRS	Clear all pressure(aftertouch) data in the pattern.
LCK	Clear parameter lock information.

# Saving and Managing Patterns

## Renaming patterns

- 1 Press **PTN**.
- 2 Press **STEP** to select the pattern for renaming.  
(STEP1 = Pattern1 ... STEP16 = Pattern16)



- 3 Press **MENU** to open the PATTERN MENU.  
Select RENAME and press the **OK** button.



- 4 After finishing, press the **OK** to save the pattern name.



# Saving and Managing Patterns

## Editing tracks within a pattern

The TRACK EDIT menu allows you to swap, copy, move, and clear tracks within a pattern.

- 1 Press **PTN**.
- 2 Press **STEP** and select a pattern.  
(STEP1 = Pattern1 ... STEP16 = Pattern16)

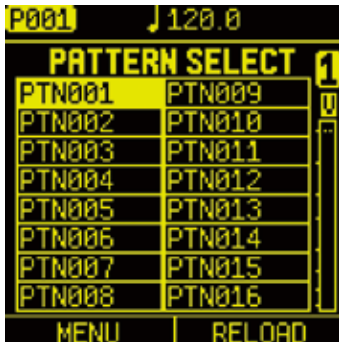

- 3 Press **Auxiliary left button MENU** to open the PATTERN MENU.

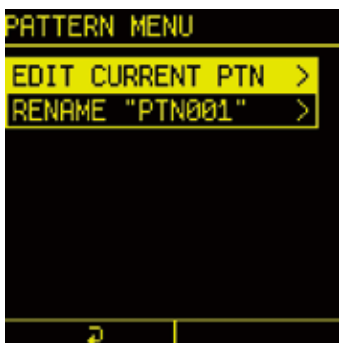

- 4 Select EDIT CURRENT PTN and press the **OK** button to open the TRACK EDIT menu.
- 5 Select the editing action you want to take and press the **OK** button.



# Saving and Managing Patterns

## Swapping tracks

- 1 Select SWAP and press the  button.



- 2 Turn  A knob to select the track to swap.

- 3 Turn  C knob to select the track swap destination.

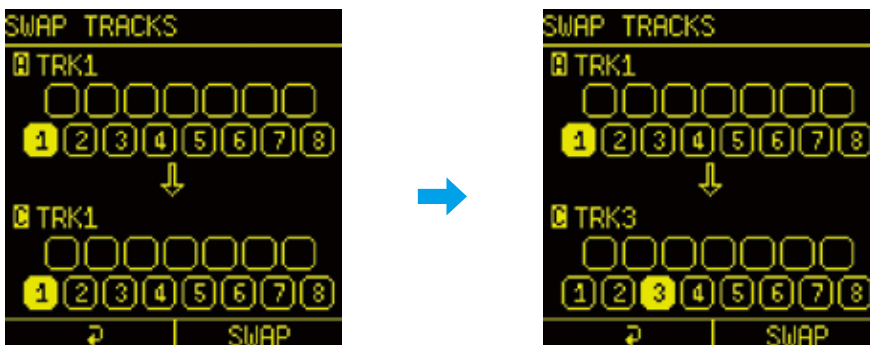

- 4 Press  Auxiliary right button **SWAP**, select YES and press the  button.



- You cannot swap between tracks 1-5 and tracks 6-8 as the selectable structures are different.

# Saving and Managing Patterns

## Copying tracks

- 1 Select COPY and press the **OK** button.



- 2 Turn **A** knob to select the track to copy.
- 3 Turn **C** knob to select the track to paste to.



- 4 Press **Auxiliary right button COPY**, select YES and press the **OK** button.



- You cannot copy between tracks 1-5 and tracks 6-8 as the selectable structures are different.

# Saving and Managing Patterns

## Moving tracks

- 1 Select **MOVE** and press the **OK** button.



- 2 Turn **A** knob to select the track to move.

- 3 Turn **C** knob to select the track move destination.



- 4 Press **Auxiliary right button MOVE**, select **YES** and press the **OK** button.



- You cannot move between tracks 1-5 and tracks 6-8 as the selectable structures are different.

# Saving and Managing Patterns

## Clearing tracks

- 1 Select CLEAR and press the  button.



- 2 Press  TRACK PAD to select a track to clear.



- 3 Press  Auxiliary right button **OK**, select YES and press the  button.



# PERFORMANCE mode

Performance mode enables you to randomize multiple tracks at the same time, or change the release time and VariSpeed of all the tracks, to improvise with your patterns.

This creates dynamic changes in the performance of your patterns without affecting the underlying patterns themselves. When you exit Performance mode, normal pattern playback resumes.

## Activate Performance mode

1 Press **func** + **MUTE** performance button.

Press the **CLR** button to exit Performance mode and return to normal playback mode.



### Enable all-tracks stuttering.

While stuttering, press **func** to make all tracks stutter at once.

### Switch the note value setting when stuttering all tracks.

(Up is 1/64, left is 1/16, down is 1/4, right is 1/1, diagonals are the in-between note values.)



Edit Performance mode settings

Return to normal playback mode

Control stuttering for the selected track.



# PERFORMANCE mode



PERFORMANCE		
Ⓐ knob	VARI SPEED	<p><b>-50.0% - +100% (Limitation up to BPM250):</b> This effect recreates the VARI SPEED function of a tape recorder by linking tempo and pitch changes within a range of <math>\pm 1</math> octave.</p> <p>Set in a positive direction, the pitch will increase and the tempo will get faster. In a negative direction, the pitch will decrease and the tempo will get slower.</p>
ⓐ A (Push) +D-Pad		<p><b>Right: -50%, Right + Down: -37.5%, Down: -25%</b> <b>Left + Down: 0%, Left: +50%, Left + Up: +75%</b> <b>Up: +100%</b> (upper limit BPM 250) Changes in the following ranges</p>
Ⓑ knob	Release All	<p><b>-12.5% - 800%:</b> Control all track release times at once. The release times will change relative to the release values set in the tracks.</p>
Ⓒ knob	Length All	<p><b>OFF, 1% - 100%:</b> Reduce all track sequence length at once. The lengths will be reduced relative to the length values set in each track.</p>
Ⓓ knob	RND STEP All	<p><b>Off, 16, 8, 4, 2, 1:</b> Change the random step values of all tracks at once.</p>

# PERFORMANCE mode

---

PERFORMANCE		
 D (Push)	RND STEP SELECT	Press a TRACK PAD while holding down the knob to turn RND STEP on or off for the selected track. (Tracks with RND STEP on will light up orange.)
 Auxiliary left button	REVERT	Revert all parameter value changes made in Performance mode.
 Auxiliary right button	MUTE BUS	Mute all input signals to the EFX BUS.

# PERFORMANCE mode

## Stutter playback across all tracks

- 1 Press and hold the ● step(s) you want to stutter.
- 2 Press **func** button to enable the all track stutter.
- 3 Press the D-pad to switch the stutter note division.

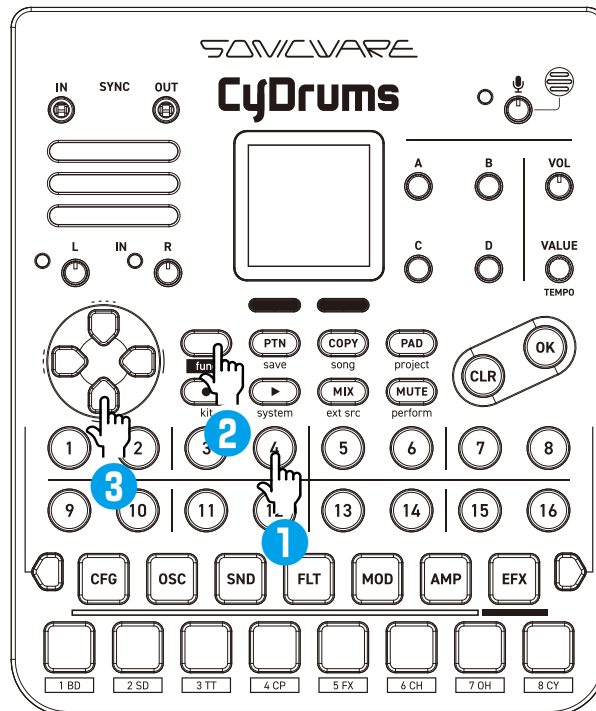

# SONG

---

The CyDrums has a song function that allows patterns that have been created to be specified and played back consecutively. The number of repetitions, the number of bars in each pattern and the tempo can be specified as desired to create a musical composition.

## Playing songs

- 1 Press **func** + **COPY** song to open the SONG SELECT menu.

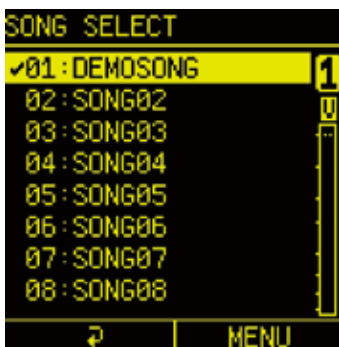

- 2 Select a song and press the **OK** button.
- 3 Press **OK** + **▶** to play the SONG.  
While playing a song, the **▶** button lights yellow.



- While a song is playing, press **OK** + **PTN** to loop playback of the pattern (PTN lights yellow).
  - Press **PTN** again to return to song playback.
-

# SONG

---

## Editing songs

- 1 Press **func** + **copy** song to open the SONG SELECT menu.



- 2 Move the cursor over the song you want to edit, and press the **Auxiliary right button MENU**.



- 3 Select EDIT and press the **OK** button to open SONG EDIT.

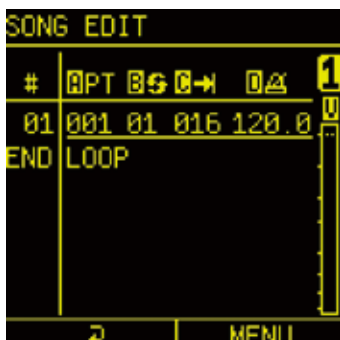

# SONG

## SONG EDIT operations

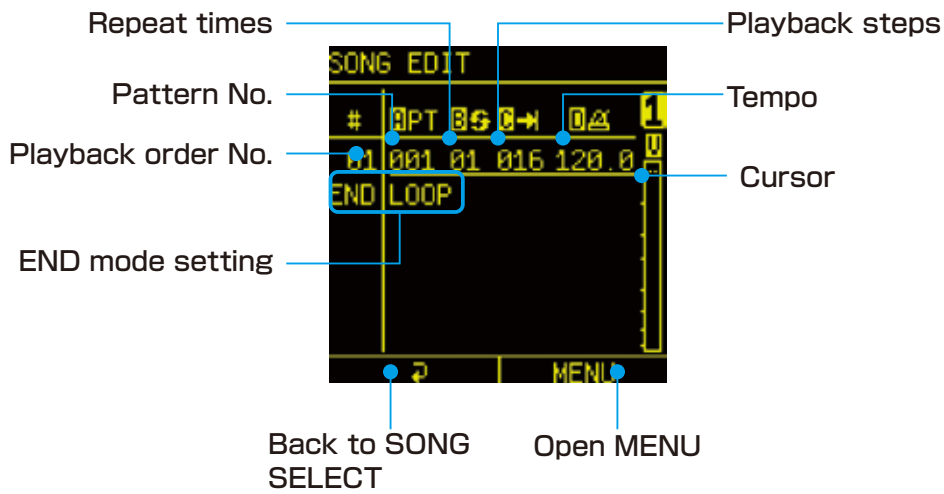

**Move cursor position**  
Press D-pad to move the cursor up/down/left/right.

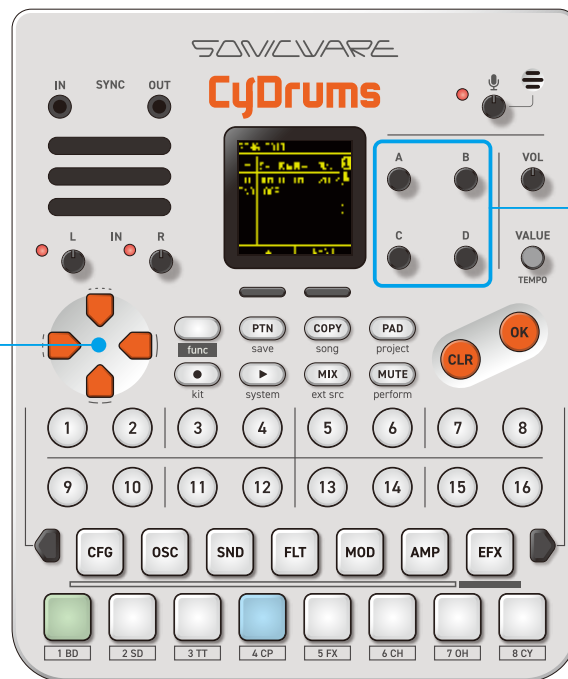

**Editing pattern settings**

# SONG

## SONG EDIT operations

- 1 Use  $\text{A} - \text{D}$  to edit patterns.

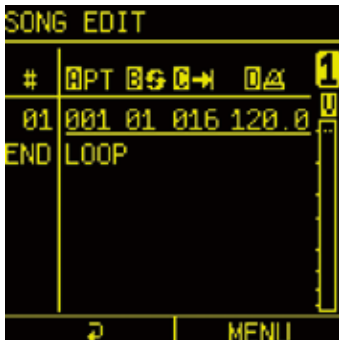

- 2 Press the  $\text{Menu}$  Auxiliary right button **Menu** to open the SONG EDIT MENU, which allows you to insert, delete, and enable/disable patterns.

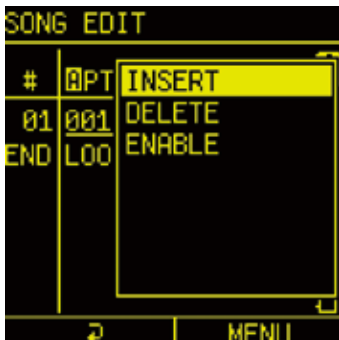

### SONG EDIT MENU

INSERT	Insert a new Pattern after the selected Pattern.
DELETE	Delete the selected Pattern
ENABLE	Disable the selected Pattern



- Up to 99 patterns can be added to a song.



# SONG

SONG EDIT	
ⓂA knob	Select pattern (the pattern name will pop up).
	(When END mode selected) <b>ONCE:</b> After the last song pattern is played, song playback will stop without looping.  <b>LOOP:</b> After the last song pattern is played, song playback will loop from the first.
ⓂB knob	Pattern playback repetitions
ⓂC knob	Number of steps for pattern playback
ⓂD knob	Pattern tempo setting

**3** Repeat procedure 1-2 to create the song.

**4** When done editing, press the  Auxiliary left button to exit SONG EDIT.



- Turn  + ⓂC knob to increase/decrease number of steps for pattern playback in increments of 16.
- In SONG EDIT, if you want to play from a specific row number, move the cursor to the desired location and press .



# SONG

---

## Renaming songs

- 1 Press **func** + **COPY** song to open the SONG SELECT menu.



- 2 Move the cursor over the song you want to rename, and press the  Auxiliary right button **MENU**.
- 3 Select RENAME and press the  button.



- 4 Edit the name and press the  Auxiliary right button to complete renaming.



# SONG

---

## Clearing songs

- 1 Press **func** + **COPY** song to open the SONG SELECT menu.



- 2 Move the cursor over the song you want to clear, and press the **Auxiliary right button MENU**.

- 3 Select CLEAR and press the **OK** button.



- 4 Select YES and press the **OK** button.



- Use this operation with caution because clearing a song will delete it from the project and this cannot be undone.
-

# SONG

---

## Copying a song

- 1 Press **func** + **COPY** song to open the SONG SELECT menu.



- 2 Move the cursor over the song you want to copy, and press the **Auxiliary right button MENU**.

- 3 Select COPY and press the **OK** button.



- 4 Select the song you want to paste to and press the **OK** button.

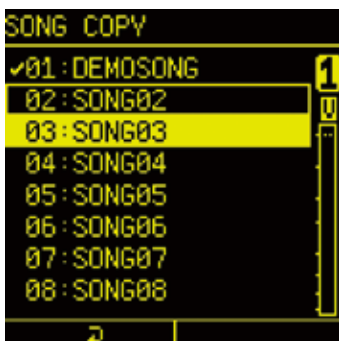

# Managing Projects

---

The PROJECT MENU allows you to open, save, delete, rename, and create new projects.

Select from the menu to execute these actions as needed.

Press **func** + **PAD** project to open PROJECT MENU.

## Creating new projects

- 1 In the PROJECT MENU, select SELECT/NEW.



- 2 Select EMPTY and press the **OK** button.

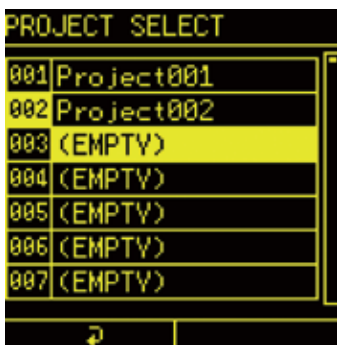

- 3 Select YES to save the current project, and press the **OK** button.

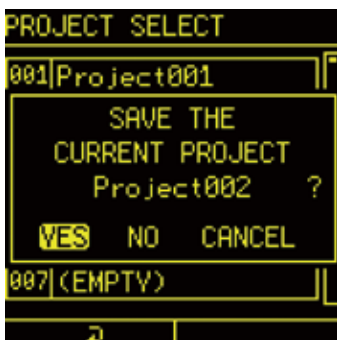

# Managing Projects

---

## Saving projects

- 1 In the PROJECT MENU, select SAVE and press the  button.



- 2 Select YES and press the  button.

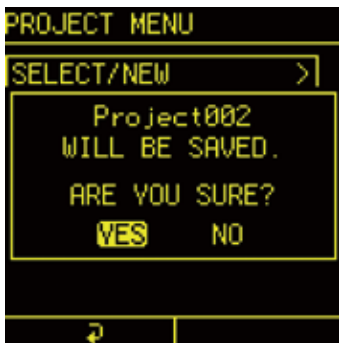

- Only saving the project will not save the patterns. Be aware that they need to be saved individually.  
See "Saving patterns" ( → P.105)
-

# Managing Projects

## Saving as a different project

- 1 In the PROJECT MENU, select SAVE AS and press the **OK** button.



- 2 Select the save destination and press the **OK** button.

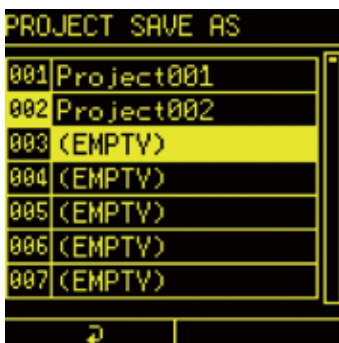

- 3 Use the direction and **OK** buttons to change the name. Then press the **OK** Auxiliary right button **OK**.



If you want to cancel saving, press the **OK** Auxiliary left button **Back**.



# Managing Projects

---

## Renaming projects

- 1 In the PROJECT MENU, select RENAME and press the  button.



- 2 Use the direction and  buttons to change the name. Then press the  Auxiliary right button **OK**.



# Managing Projects

---

## Deleting projects

- 1 In the PROJECT MENU, select DELETE and press the **OK** button.



- 2 Select YES and press the **OK** button.

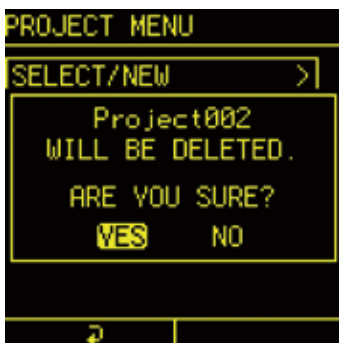

- Use this operation with caution because deleting a project cannot be undone.
-

# Managing sound patches

---



In Sound Patch Search you can also save, delete, import, and export sound patches.

Select from the menu as needed to execute these actions.

Press the A knob on the SND page to display Sound Patch Search.



## Loading the selected Sound Patch into the track

- 1 Select a sound patch
- 2 Press  Auxiliary right button **MENU** to open MENU.
- 3 Select LOAD and press the  button.







- A sound patch can also be loaded by pressing the  button when the sound patch is selected.
-

# Managing sound patches

---

## Saving a sound patch

- 1 Turn the  knob to select a slot to store.
- 2 Press  Auxiliary right button **MENU** to open MENU.
- 3 Select SAVE and press the  button.
- 4 Select YES and press the  button.







- If you overwrite a slot that already contains a sound patch, you will not be able to revert to the state of the sound patch before executing SAVE, so please be careful when performing this operation.
  - If you want to save a sound patch as a copy, select an empty slot and execute SAVE.
-

# Managing sound patches





---

## Renaming the sound patch name

- 1 Turn the  knob to select a slot to rename.
- 2 Press  Auxiliary right button **MENU** to open MENU.
- 3 Select RENAME and press the  button.
- 4 Edit the name and press the  Auxiliary right button to complete renaming.



## Deleting a sound patch

- 1 Turn the  knob to select a slot to delete.
- 2 Press  Auxiliary right button **MENU** to open MENU.
- 3 Select DELETE and press the  button.
- 4 Select YES and press the  button.







- Perform this operation with caution because deleting a project cannot be undone.
-

# Managing sound patches

---

## Import a EFX patch from external memory Card

- 1 Turn the  knob to select the slot to which you want to import a sound patch.
- 2 Press  Auxiliary right button **MENU** to open MENU.
- 3 Select IMPORT and press the  button.
- 4 Turn the  knob to select a sound patch to import a sound patch.



- 5 Select YES and press the  button to execute the import.



# Managing sound patches

---

- 6** Select YES and press the **OK** button to delete the original file from the External storage card.

If you want to keep the original files on the External storage card, select NO.





- If you overwrite an existing sound patch, you will not be able to restore the sound patch to its previous state, so please be careful when doing this.
-

# Managing sound patches

---

## Export a sound patch

- 1** Turn the  knob to select the sound patch you want to export.
- 2** Press  Auxiliary right button **MENU** to open MENU.
- 3** Select EXPORT and press the  button.





- 
- The sound patch will be exported to the Contents folder on the external storage card.
-



# Managing DrumKits

---

## Import a DrumKit from external storage Card

- 1 Turn the  knob to select the slot to which you want to import a DrumKit.
- 2 Press  Auxiliary right button **MENU** to open MENU.
- 3 Select IMPORT and press the  button.







- 4 Turn the  knob to select a DrumKit to import.
- 5 Press the  button or the  Auxiliary right button **IMPORT** to execute the import.



- Up to 128 DrumKits can be saved.
- 

## Export a DrumKit

- 1 Press  +  kit button to open DRUM KIT menu.
  - 2 Turn the  knob to select a slot to export a DrumKit.
  - 3 Press  Auxiliary right button **MENU** to open MENU.
  - 4 Select EXPORT and press the  button.
-

# Importing various data at once

---

You can import all the backed up patch data and drum kit data at once.

## Importing Sound Patches at once

- 1 Press **func** + **▶** system to open the SYSTEM MENU.
- 2 Select import and press the **OK** button to open the IMPORT menu.



- 3 Select SND PATCH and press the **OK** button.



- 4 Press **⏏** Auxiliary right button **IMPORT**.

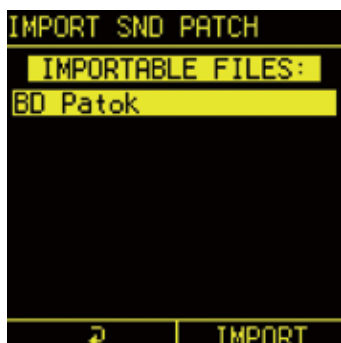

The sound patches will be imported to the earliest available slot numbers.

# Importing various data at once

---

## Importing DrumKits at once

- 1 Press **func** + **▶** system to open the SYSTEM MENU.
- 2 Select import and press the **OK** button to Open the IMPORT menu.



- 3 Select DRUM KIT and press the **OK** button.



- 4 Press **◁** Auxiliary right button **IMPORT**.



They will be imported into the earliest slot number available first.

# Importing various data at once

---

## Importing EFX Patches at once

- 1 Press **func** + **▶** system to open the SYSTEM MENU.
- 2 Select IMPORT and press the **ok** button to open the IMPORT menu.



- 3 Select EFX PATCH and press the **ok** button.



- 4 Press **⏏** Auxiliary right button **IMPORT**.



# Importing various data at once

---

- 5 Select the BANK which you want to import and press the  button.



- 6 Select YES and press the  button.



The EFX patches will be imported to the earliest available slot numbers.

# Clock Synchronization with External Devices

Multiple devices, including external synthesizers and drum machines, can be connected to the MIDI and SYNC connectors, allowing them to be synchronized and used together.

## Connecting with other devices

- 1 Connect other devices to the MIDI and SYNC connectors.

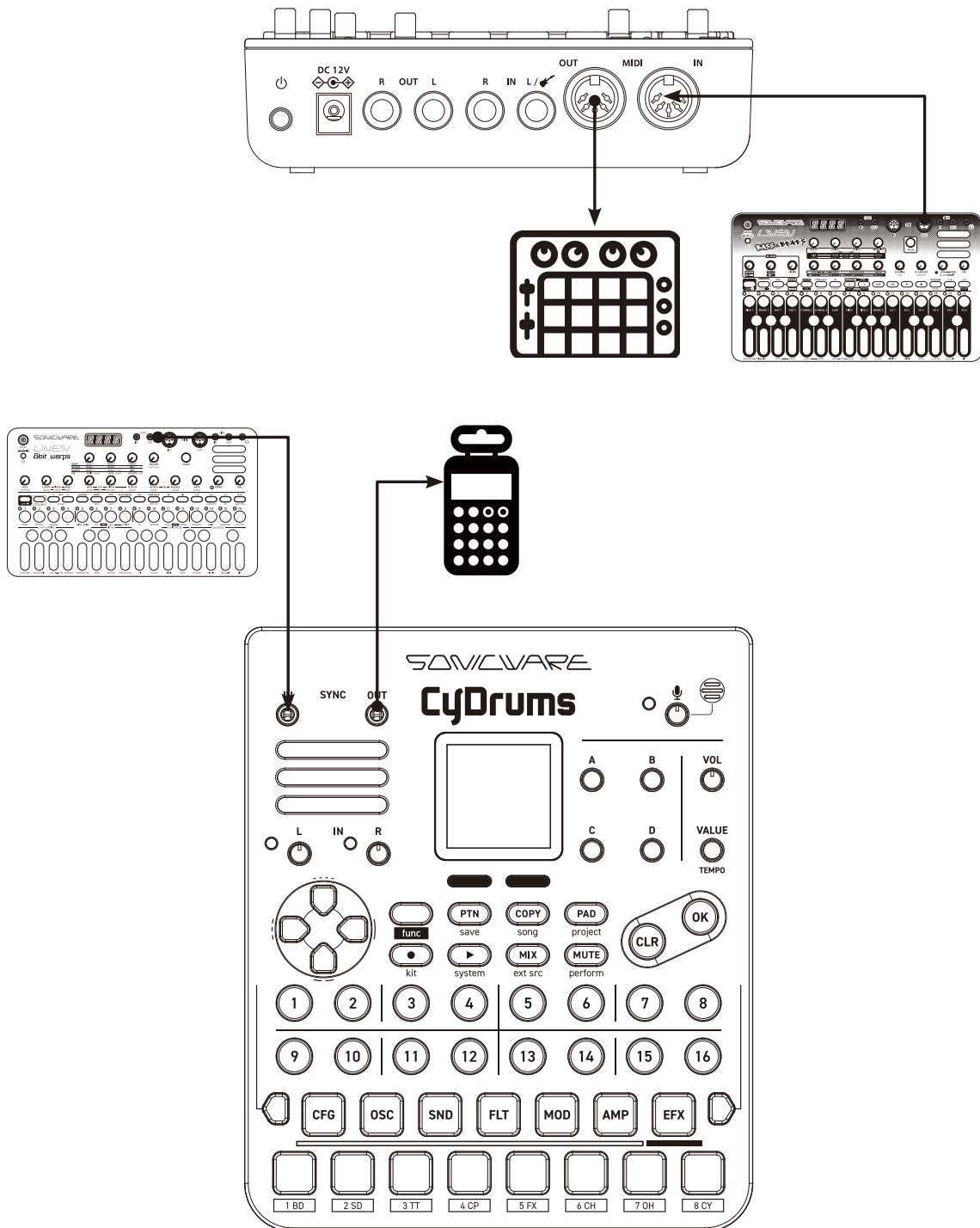

# Clock Synchronization with External Devices

---

- 1 Press **func** + **▶** system to open the SYSTEM MENU.
- 2 Select CLOCK and press the **OK** button.



- 3 Set each item in the CLOCK settings.



# Clock Synchronization with External Devices

CLOCK	
SOURCE	<p><b>INTERNAL :</b> Use the built in clock. The CyDrums will operate as the master when used by itself or synchronizing other devices.</p> <p><b>MIDI:</b> The CyDrums will synchronize with MIDI clock received through MIDI IN.</p> <p><b>SYNC:</b> The CyDrums will synchronize with clock signals received through SYNC IN.</p>
TEMPO LED	<p>The LED (VALUE knob) will light along with the synchronized tempo. When set to OFF, the LED will not blink during normal playback.</p>
POLARITY IN	<p>This switches the polarity of the SYNC IN jack between <b>RISE</b> (+ / waveform rising) and <b>FALL</b> ( - / waveform falling). Set this to match the sync polarity of the connected device.</p>
POLARITY OUT	<p>This switches the polarity of the SYNC OUT jack between <b>RISE</b> (+ / waveform rising) and <b>FALL</b> ( - / waveform falling). Set this to match the sync polarity of the connected device.</p>

# MIDI

## Setting track MIDI channels

MIDI channel numbers can be set for every CyDrums tracks.

- 1 Press **func** + **▶** system to open the SYSTEM MENU.
- 2 Select MIDI and press the **OK** button to open the MIDI SETTING.



- 3 Select TRACK and press the **OK** button.



- 4 Select the track to change, and turn **⌚A** knob to change the channel.

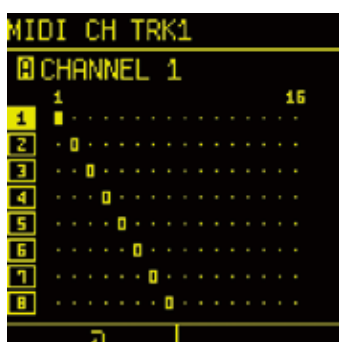

# MIDI

## Setting MIDI channels for the unit

- 1 Press **func** + **▶** system to open the SYSTEM MENU.
- 2 Select MIDI and press the **OK** button to open the MIDI SETTING.



- 3 Select CHANNEL and press the **OK** button.

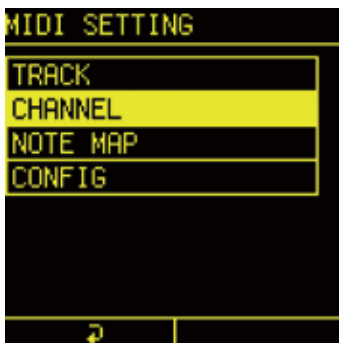

- 4 Use **Ⓜ**A - D knobs to change settings.

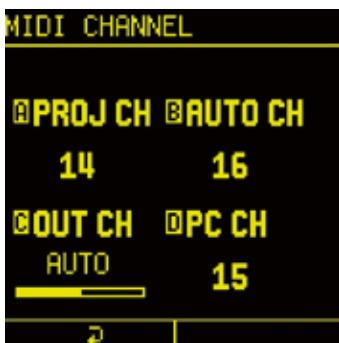

# MIDI

MIDI CHANNEL		
ⓂA knob	PROJECT CHANNEL	This channel is for receiving MIDI data related to project-level parameters.
ⓂB knob	AUTO CHANNEL	MIDI received on this channel will play the currently selected track. This is also the channel number used when the OUTPUT CHANNEL is set to AUTO.
ⓂC knob	OUTPUT CHANNEL	Channel used for output  <b>AUTO:</b> Use the AUTO CHANNEL number  <b>TRACK:</b> Use the channel numbers set for each track.
ⓂD knob	PROGRAM CHANGE CHANNEL	Channel used for sending and receiving program changes.

# MIDI

---

## Making other MIDI settings

- 1 Press **func** + **▶** system to open the SYSTEM MENU.
- 2 Select MIDI and press the **OK** button to open the MIDI SETTING.



- 3 Select CONFIG and press the **OK** button.



# MIDI



## MIDI CHANNEL 1/3

INPUT FROM	Set connectors used to receive MIDI
OUTPUT TO	Set connectors used to send MIDI
TX NOTE	Turn note transmission on/off
TX CONTROL CHANGE	Turn control change transmission on/off

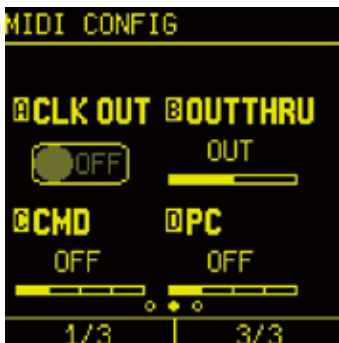

## MIDI CHANNEL 2/3

CLOCK OUT	Turn clock output on/off
OUT / THRU	Switch between MIDI OUT and THRU
COMMAND	Set command data transmitting (TX) and receiving (RX)
PROGRAM CHANGE	Turn program change transmission on/off

# MIDI

---



## MIDI CHANNEL 3/3

ACTIVE SENSING	Set active sensing transmitting (TX) and receiving (RX)
----------------	---

# MIDI

## Editing MIDI NOTE MAP

By editing the MIDI NOTE MAP, you can control CyDrums as a drum sound module from an external controller such as a MIDI drum pad.



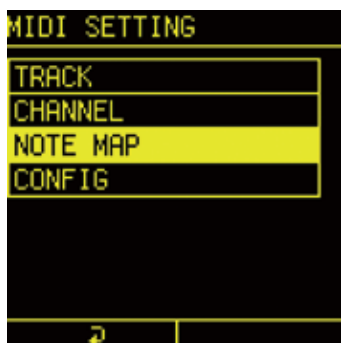

- 1 Press **func** + **▶** system to open the SYSTEM MENU.
- 2 Select MIDI and press the **OK** button to open the MIDI SETTING.
- 3 Select NOTE MAP and press the **OK** button.



- 4 Press D-pad or **□** TRACK PAD to select the track to edit.
- 5 Use **⌵** A/B knobs to change settings.

# MIDI

---

MIDI NOTE MAP		
 A knob	PAD CH	Sets the MIDI CH to receive with MIDI NOTE MAP. If the same MIDI CH is set in another MIDI setting, MIDI NOTE MAP takes priority.
 B knob	NOTE	Set the MIDI NOTE for each track. When the same MIDI NOTE is received on the PAD CH, the track will sound.



- It does not reflect the Pressure of notes received via MIDI NOTE MAP.  
For tracks where you want to use MOD aftertouch, use the track's MIDI channel.
-

# Changing mute mode

---

The mute behavior can be changed.

- 1 Press **func** + **▶** system to open the SYSTEM MENU.
- 2 Select TRACK MUTE and press the **OK** button.



- 3 Turn **⊖** A knob to change it.



TRACK MUTE	
SND	This mutes sound of the track. The track will not sound until mute is turned off.
PTN	This mutes sequences of the track. Pads can still be played while the track is muted.

# Pad sensitivity setting

## Pad Velocity Sensitivity

- 1 Press **func** + **▶** system to open the SYSTEM MENU.
- 2 Select PAD and press the **OK** button.



- 3 Turn **A** knob to adjust a fixed velocity.  
Turn **B** knob to adjust a velocity curve.



PAD VELOCITY	
1 - 127	Velocity is always at this fixed value.
SP SOFT	This is best for people who play with an especially light touch.
SOFT	This is best for people who play with a moderately light touch.
LINEAR	The velocity will change linearly in response to how hard the LED pads are tapped.
HARD	This is best for people who play with a moderately heavy touch.
SP HARD	This is best for people who play with an especially heavy touch.

# Pad sensitivity setting

---

## Changing the Pad Aftertouch Curve

- 1 Press **func** + **▶** system to open the SYSTEM MENU.
- 2 Select PAD and press the **OK** button.



- 3 Turn **A** knob to adjust an Aftertouch threshold.  
Turn **B** knob to adjust an Aftertouch curve.



# Pad sensitivity setting

PAD AFTERTOUCH SETTINGS			
Ⓐ knob	After touch threshold	<b>1 - 5:</b> Sets the threshold at which aftertouch modulation begins. The higher the value, the harder you need to press.	
Ⓑ knob	After touch curve	SP SOFT	This is best for people who play with a light touch.
		SOFT	This is best for people who play with a moderately light touch.
		LINEAR	The modulation will change linearly in response to how hard the LED pads are tapped.
		HARD	This is best for people who play with a moderately heavy touch.
		SP HARD	This is best for people who play with an especially heavy touch.

# Deactivating PAD transpose setting

You can deactivate the pad transpose setting. (→ P.41)

- 1 Press **func** + **▶** system to open the SYSTEM MENU.
- 2 Select PAD and press the **OK** button.



- 3 Turn **⊖**B knob to adjust it.



TRANPOSE	
ON	This activates transpose set in CFG page.
OFF	This deactivates transpose setting.

# Mute the internal speaker

---

The internal speaker can be always muted.

- 1 Press **func** + **▶** system to open the SYSTEM MENU.
- 2 Select SPEAKER MUTE and press the **OK** button.



- 3 Turn **⊗**A knob to change.

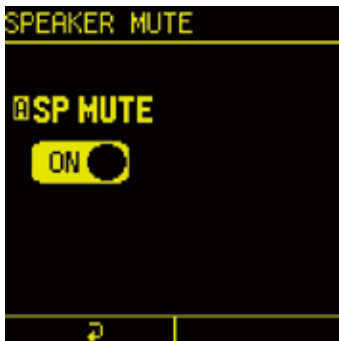

SPEAKER MUTE	
ON	Mute on
OFF	Mute off

# Disabling to switch the page in page select menu

- 1 Press **func** + **▶** system to open the SYSTEM MENU.
- 2 Select PATTERN SELECT and press the **OK** button.



- 3 Use **Ⓜ**A knob to change settings.

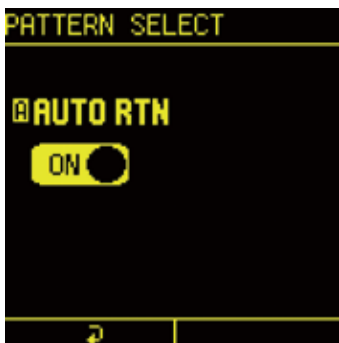

AUTO RTN	
ON	When you press <b>OK</b> in the PTN SELECT menu, you will return to the parameter editing page that you last opened.
OFF	When you press <b>OK</b> in the PTN SELECT menu, you will stay in the menu.

# Card functions

---

## Card reader mode

You can access backups of various exported patch data, project data, and user data, for example, from your PC/Mac.

This mode is also used when updating firmware.

- 1 Connect to a PC/Mac with a USB cable.
- 2 Press **func** + **▶** system to open the SYSTEM MENU.
- 3 Select CARD and press the **OK** button.



- 4 Select CARD READER and press the **OK** button.



- 5 Select YES and press the **OK** button.



- Any unsaved PTN edits will be lost, so be sure to save the pattern beforehand (→ P.105).
-

# Card functions

## Testing card performance

The performance of the card being used can be measured to determine whether it can be used with the CyDrums.

- 1 Press **func** + **▶** system to open the SYSTEM MENU.
- 2 Select CARD and press the **OK** button.

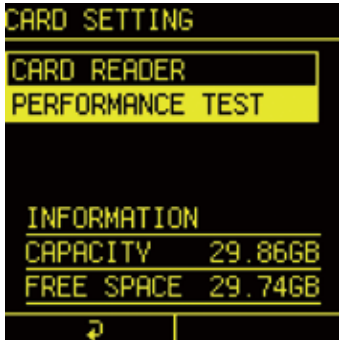

- 3 Select PERFORMANCE TEST and press the **OK** button.



- 4 Press the **OK** button to start the test.



RESULT : OK	The card can be used with the CyDrums.
RESULT : NG	The card cannot be used with the CyDrums.

# Changing POWER Settings

## Battery setting

By setting the type of batteries used in the CyDrums, the battery icon on the screen can be displayed correctly.

1 Press **func** + **▶** system to open the SYSTEM MENU.

2 Select BATTERY and press the **OK** button.



3 Turn **⊕**A knob to adjust it.



BATTERY TYPE	
Alkaline	Alkaline batteries
NiMH	Nickel-metal hydride batteries
Lithium	Lithium batteries

# Changing POWER Settings

---

## Automatic power off function

The time until automatic shutdown can be set.

- 1 Press **func** + **▶** system to open the SYSTEM MENU.
- 2 Select AUTO POWER OFF and press the **ok** button.



- 3 Turn  A knob to select a time between 30 minutes and 6 hours (or Off to disable the AUTO POWER OFF function).



# Resetting the unit to the factory default state

---

The CyDrums can be restored to its factory default settings.

**1** Press **func** + **▶** system to open the SYSTEM MENU.

**2** Select RESET and press the **OK** button.

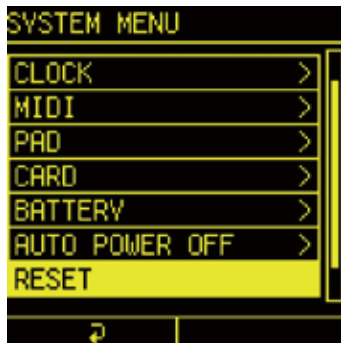

**3** Select YES and press the **OK** button.



# System information

---

## Checking system version information

- 1 Press **func** + **▶** system to open the SYSTEM MENU.
- 2 Select INFORMATION and press the **OK** button.

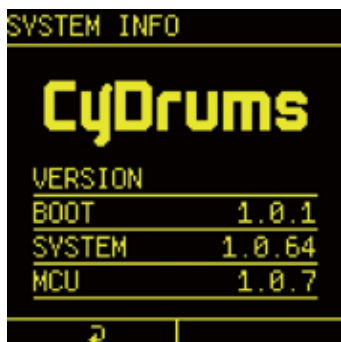
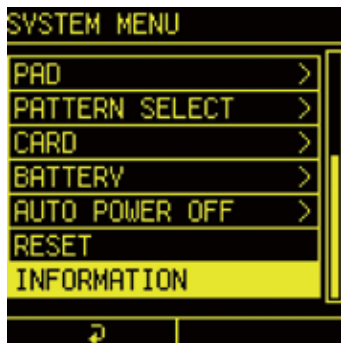

# Firmware updates

---

The CyDrums firmware can be updated by connecting the CyDrums to a PC or Mac by USB and transferring an update file.

- 1 Copy the downloaded firmware (.bin) to the root folder on the card.

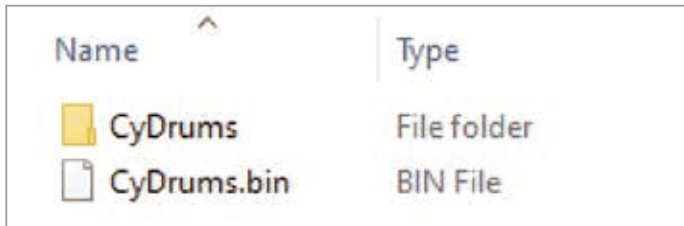

Name	Type
CyDrums	File folder
CyDrums.bin	BIN File

- 2 While pressing **PAD**, press and hold the power button.
- 3 Select SYSTEM UPDATE and press the **OK** button.
- 4 Select YES and press the **OK** button to start the update.
- 5 After it completes, press the power button to shut down the unit. Then, restart it by pressing the power button again.

# If an error message appears during startup

If the following error message appears when starting CyDrums, the necessary file data on the external storage card may be corrupted or missing.



Please follow the steps below to resolve this issue.

- 1 Connect the CyDrums to a PC or Mac by USB.
- 2 Scan the displayed QR code and download the CyDrums folder from the linked Support > Download page.



- 3 Decompress the downloaded .zip file and copy the CyDrums folder to the root folder on the card.

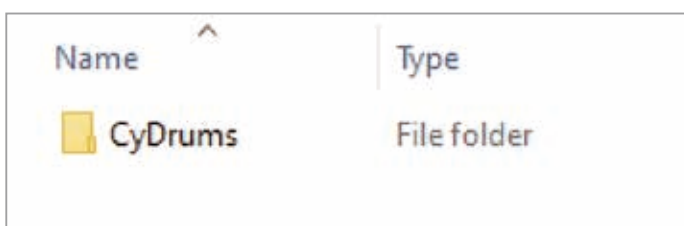

- 4 After it completes, press the power button to shut the unit down. Then, restart it.

# Appendix

## Sound architecture

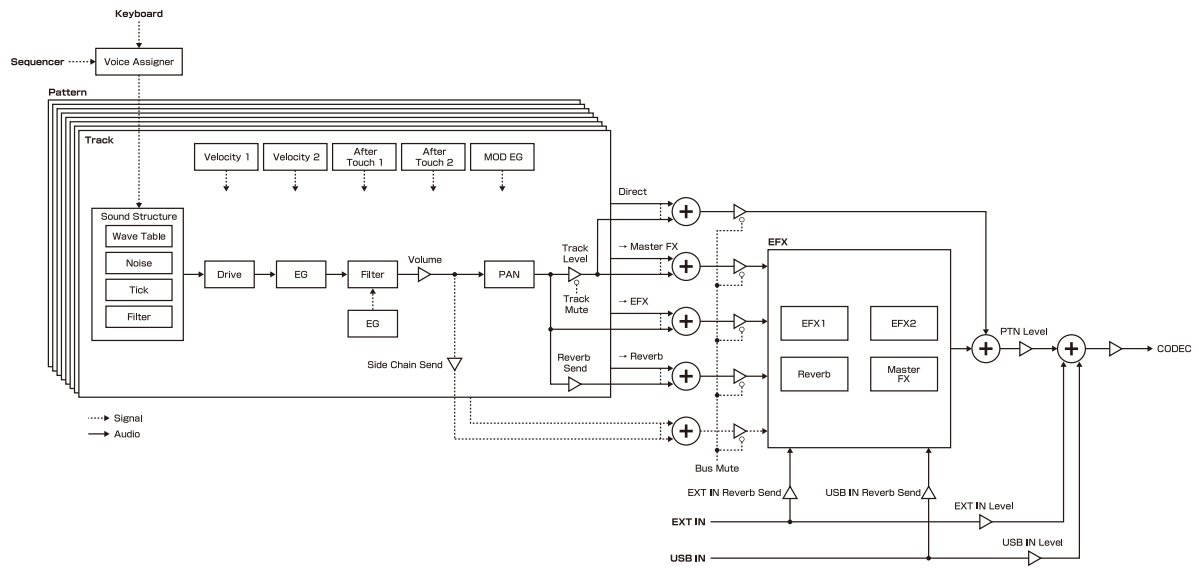

# Structure List

## BD STANDARD

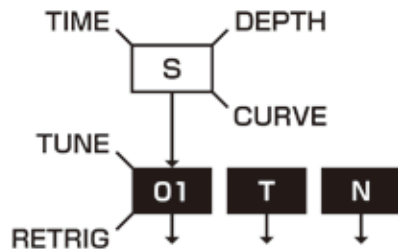

This is a basic Bass Drum structure with one OSC (oscillator).

Synthesis is performed by applying a pitch sweep to the OSC.

Noise and Tick modules are combined to create a transient sound with a sense of attack.

BD STANDARD			
OSC			
A knob	Wave	1 - 64	Select a Wavetable.
B knob	Release	0 - 127	Adjust the release time. It can also be edited on AMP page. (→ P.68)
C knob	Direction	1 - 16	Select the way that the Wavetable will be scanned.
D knob	Speed	0 - 127	Adjust the speed at which the Wavetable will be scanned.
B (Push)	End	0 - 127	Adjust the end point of Wavetable scanning
C (Push)	Start	0 - 127	Adjust the start point of Wavetable scanning
D (Push)	Curve	-63 - 63	Adjust the curve of the speed of Wavetable scanning

# Structure List

## BD STANDARD

Noise			
Ⓐ knob	Type	White, Pink, Brown, Purple, RESO	Select the Noise type.
Ⓑ knob	Frequency	0 - 127	Adjust the peak frequency of RESO Noise.
Ⓒ knob	Level	0 - 127	Adjust the level of Noise.
Ⓓ knob	Time	0 - 127	Adjust the length of time of the noise.
Tick			
Ⓐ knob	Pulse	Pulse, H-Saw, Rectangle, F-saw, Cheb, Sine, Gaus, Rapid, Hi-F, Noise	Select the type of Pulse.
Ⓑ knob	Time	0 - 127	Adjust the length of time of the Pulse.
Ⓒ knob	Volume	0 - 127	Adjust the level of the Pulse.

# Structure List

## BD STANDARD

SND			
⊗A knob	Sweep Time	0 - 127	<b>Adjust the time of the pitch sweep modulation.</b> The lower the value, the faster the sweep speed.
⊗B knob	Sweep Depth	Down63 - OFF - Up63	<b>Adjust the amount of pitch sweep.</b> DOWN makes the pitch sweep down. UP makes it sweep up. The higher the value, the more the pitch sweeps up or down.
⊗C knob	Tune	-1200 - 1200(cent)	Adjust the OSC tuning.
⊗D knob	Sweep Curve	-63 - 63	<b>Adjust the curve of the pitch sweep.</b> Negative values create a LOG curve. Positive values create an EXP curve.
⬇️ D (Push)	Retrigger	ON, OFF	When ON, the Wavetable is re-scanned each time a note is played.

# Structure List

## BD FM

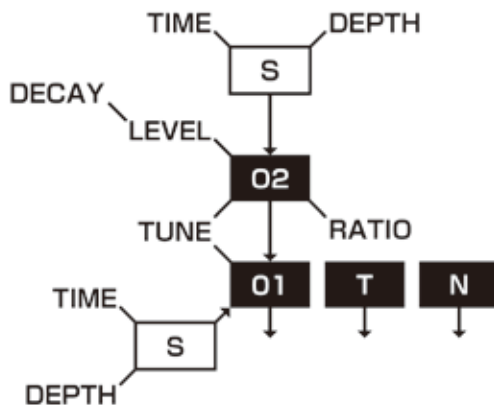

This is a Bass Drum structure that uses two OSCs and FM synthesis.

FM synthesis is performed with OSC2 as a modulator and OSC1 as a carrier.

Noise and Tick modules are combined to create a transient sound with a sense of attack.

BD FM			
OSC1&2			
⊖A knob	Wave	1 - 64	Select a Wavetable.
⊖B knob	Release	0 - 127	Adjust the release time. It can also be edited on AMP page. (→ P.68)
⊖C knob	Direction	1 - 16	Select the way that the Wavetable will be scanned.
⊖D knob	Speed	0 - 127	Adjust the speed at which the Wavetable will be scanned.
⬇B (Push)	End	0 - 127	Adjust the end point of Wavetable scanning
⬇C (Push)	Start	0 - 127	Adjust the start point of Wavetable scanning
⬇D (Push)	Curve	-63 - 63	Adjust the curve of the speed of Wavetable scanning

# Structure List

---

## BD FM

Noise			
⊞A knob	Type	White, Pink, Brown, Purple, RESO	Select the Noise type.
⊞B knob	Frequency	0 - 127	Adjust the peak frequency of RESO Noise.
⊞C knob	Level	0 - 127	Adjust the level of Noise.
⊞D knob	Time	0 - 127	Adjust the length of time of the noise.
Tick			
⊞A knob	Pulse	Pulse, H-Saw, Rectangle, F-saw, Cheb, Sine, Gaus, Rapid, Hi-F, Noise	Select the type of Pulse.
⊞B knob	Time	0 - 127	Adjust the length of time of the Pulse.
⊞C knob	Volume	0 - 127	Adjust the level of the Pulse.

# Structure List

## BD FM

SND			
⊖A knob	Decay	0 - 127	Adjust the decay time of the level parameter.
⊖B knob	Level	0 - 127	Adjust the amount of modulation of OSC2.
⊖C knob	Tune	-1200 - 1200	Adjust the OSC tuning.
⊖D knob	Ratio	0 - 127	<b>Adjust the pitch ratio of OSC2 to OSC1</b> When set to 10, the ratio is 1:1.
⬇A (Push)	Sweep Time2	Down63 - OFF - Up63	<b>Adjust the time of the pitch sweep modulation of OSC2.</b> The lower the value, the faster the sweep speed.
⬇B (Push)	Sweep Depth2	-63 - 63	<b>Adjust the amount of pitch sweep of OSC2.</b> DOWN makes the pitch sweep down. UP makes it sweep up. The higher the value, the more the pitch sweeps up or down.
⬇C (Push)	Sweep Time1	Down63 - OFF - Up63	<b>Adjust the time of the pitch sweep modulation of OSC1.</b> The lower the value, the faster the sweep speed.
⬇D (Push)	Sweep Depth1	-63 - 63	<b>Adjust the amount of pitch sweep of OSC1.</b> DOWN makes the pitch sweep down. UP makes it sweep up. The higher the value, the more the pitch sweeps up or down.

# Structure List

## BD METALIC

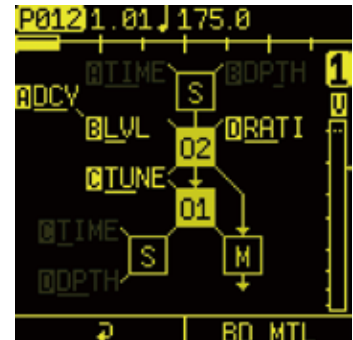
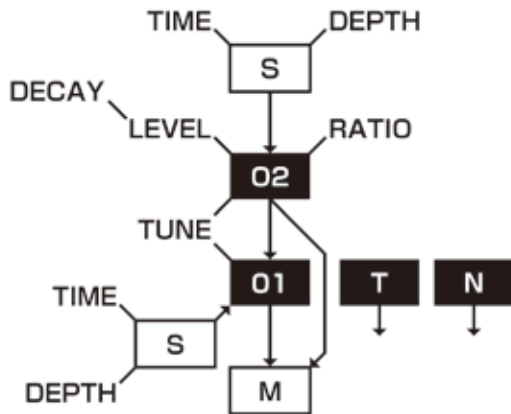

This is a Bass Drum structure that has two oscillators and uses both Ring modulation and FM synthesis.

FM synthesis is performed with OSC2 as a modulator and OSC1 as a carrier. The ring modulated signal of OSC1 and 2 is summed and added to the synthesis.

Noise and Tick modules are combined to create a transient sound with a sense of attack.

BD METALIC			
OSC1&2			
⊗A knob	Wave	1 - 64	Select a Wavetable.
⊗B knob	Release	0 - 127	Adjust the release time. It can also be edited on AMP page. ( → P.68)
⊗C knob	Direction	1 - 16	Select the way that the Wavetable will be scanned.
⊗D knob	Speed	0 - 127	Adjust the speed at which the Wavetable will be scanned.
⬇B (Push)	End	0 - 127	Adjust the end point of Wavetable scanning
⬇C (Push)	Start	0 - 127	Adjust the start point of Wavetable scanning
⬇D (Push)	Curve	-63 - 63	Adjust the curve of the speed of Wavetable scanning

# Structure List

## BD METALIC

Noise			
⊞A knob	Type	White, Pink, Brown, Purple, RESO	Select the Noise type.
⊞B knob	Frequency	0 - 127	Adjust the peak frequency of RESO Noise.
⊞C knob	Level	0 - 127	Adjust the level of Noise.
⊞D knob	Time	0 - 127	Adjust the length of time of the noise.
Tick			
⊞A knob	Pulse	Pulse, H-Saw, Rectangle, F-saw, Cheb, Sine, Gaus, Rapid, Hi-F, Noise	Select the type of Pulse.
⊞B knob	Time	0 - 127	Adjust the length of time of the Pulse.
⊞C knob	Volume	0 - 127	Adjust the level of the Pulse.

# Structure List

## BD METALIC

SND			
⊖A knob	Decay	0 - 127	Adjust the decay time of the level parameter.
⊖B knob	Level	0 - 127	Adjust the amount of modulation of OSC2.
⊖C knob	Tune	-1200 - 1200	Adjust the OSC tuning.
⊖D knob	Ratio	0 - 127	<b>Adjust the pitch ratio of OSC2 to OSC1</b> When set to 10, the ratio is 1:1.
⬇A (Push)	Sweep Time2	Down63 - OFF - Up63	<b>Adjust the time of the pitch sweep modulation of OSC2.</b> The lower the value, the faster the sweep speed.
⬇B (Push)	Sweep Depth2	-63 - 63	<b>Adjust the amount of pitch sweep of OSC2.</b> DOWN makes the pitch sweep down. UP makes it sweep up. The higher the value, the more the pitch sweeps up or down.
⬇C (Push)	Sweep Time1	Down63 - OFF - Up63	<b>Adjust the time of the pitch sweep modulation of OSC1.</b> The lower the value, the faster the sweep speed.
⬇D (Push)	Sweep Depth1	-63 - 63	<b>Adjust the amount of pitch sweep of OSC1.</b> DOWN makes the pitch sweep down. UP makes it sweep up. The higher the value, the more the pitch sweeps up or down.



# Structure List

## SD STANDARD

Noise			
Ⓐ knob	Type	White, Pink, Brown, Purple, RESO	Select the Noise type.
Ⓑ knob	Frequency	0 - 127	Adjust the peak frequency of RESO Noise.
Ⓒ knob	Level	0 - 127	Adjust the level of Noise.
Ⓓ knob	Time	0 - 127	Adjust the length of time of the noise.
Tick			
Ⓐ knob	Pulse	Pulse, H-Saw, Rectangle, F-saw, Cheb, Sine, Gaus, Rapid, Hi-F, Noise	Select the type of Pulse.
Ⓑ knob	Time	0 - 127	Adjust the length of time of the Pulse.
Ⓒ knob	Volume	0 - 127	Adjust the level of the Pulse.

# Structure List

## SD STANDARD

SND			
🕒 A knob	Tail	0 - 127	Adjust the amount of time OSC1 and 2 make sound.
🕒 B knob	Balance	63 - 63	Adjust the volume balance between OSC1 and 2.
🕒 C knob	Tune	-1200 - 1200	Adjust the OSC tuning.
🕒 D knob	Ratio	0 - 127	<b>Adjust the pitch ratio of OSC2 to OSC1</b> When set to 0, the ratio is 1:1.
⬇️ A (Push)	Sweep Depth	Down63 - OFF - Up63	<b>Adjust the amount of pitch sweep.</b> DOWN makes the pitch sweep down. UP makes it sweep up. The higher the value, the more the pitch sweeps up or down.
⬇️ B (Push)	Sweep Time	0 - 127	<b>Adjust the time of the pitch sweep modulation.</b> The lower the value, the faster the sweep speed.
⬇️ C (Push)	Level	0 - 127	Adjust the volume level of OSC1 and 2.
⬇️ D (Push)	Tone	0 - 127	Adjust the tone of the dedicated Low-Pass Filter, applied after the OSCs are mixed.

# Structure List

## SD FM

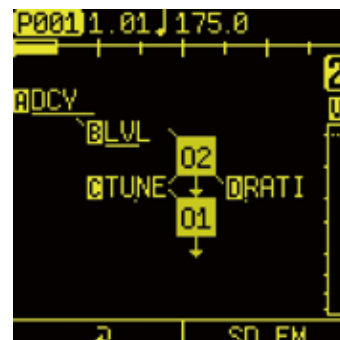
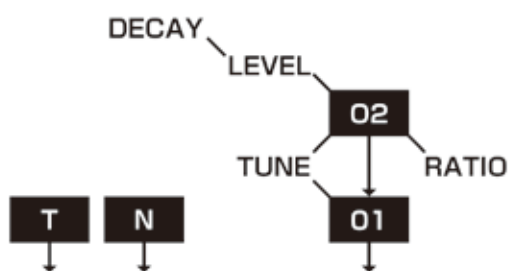

This is a basic Snare Drum structure that uses two OSCs and FM synthesis. FM synthesis is performed using OSC2 as the modulator and OSC1 as the carrier. Noise and Tick modules are combined to create a transient sound with a sense of attack.

SD FM			
OSC1&2			
⊗A knob	Wave	1 - 64	Select a Wavetable.
⊗B knob	Release	0 - 127	Adjust the release time. It can also be edited on AMP page. (→ P.68)
⊗C knob	Direction	1 - 16	Select the way that the Wavetable will be scanned.
⊗D knob	Speed	0 - 127	Adjust the speed at which the Wavetable will be scanned.
⊗ B (Push)	End	0 - 127	Adjust the end point of Wavetable scanning
⊗ C (Push)	Start	0 - 127	Adjust the start point of Wavetable scanning
⊗ D (Push)	Curve	-63 - 63	Adjust the curve of the speed of Wavetable scanning

# Structure List

## SD FM

Noise			
Ⓐ knob	Type	White, Pink, Brown, Purple, RESO	Select the Noise type.
Ⓑ knob	Frequency	0 - 127	Adjust the peak frequency of RESO Noise.
Ⓒ knob	Level	0 - 127	Adjust the level of Noise.
Ⓓ knob	Time	0 - 127	Adjust the length of time of the noise.
Tick			
Ⓐ knob	Pulse	Pulse, H-Saw, Rectangle, F-saw, Cheb, Sine, Gaus, Rapid, Hi-F, Noise	Select the type of Pulse.
Ⓑ knob	Time	0 - 127	Adjust the length of time of the Pulse.
Ⓒ knob	Volume	0 - 127	Adjust the level of the Pulse.

# Structure List

---

## SD FM

SND			
Ⓐ knob	Decay	0 - 127	Adjust the decay time of the level parameter.
Ⓑ knob	Level	0 - 127	Adjust the amount of modulation of OSC2.
Ⓒ knob	Tune	-1200 - 1200	Adjust the OSC tuning.
Ⓓ knob	Ratio	0 - 127	<b>Adjust the pitch ratio of OSC2 to OSC1</b> When set to 10, the ratio is 1:1.

# Structure List

## SD TONE

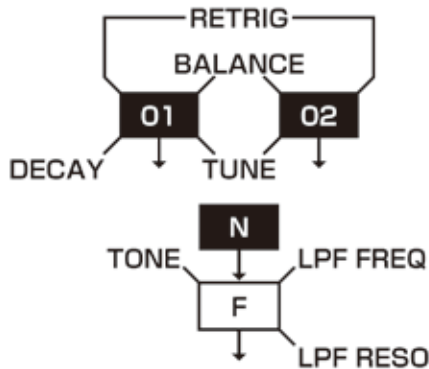

This is a snare drum structure inspired by classic 80s drum machines.

OSC2 is a dedicated circuit that uses noise as its source of pitch modulation, recreating a snappy sound that cannot be produced by the Noise module.

The Noise module's tone can be adjusted by a dedicated filter module.

SD TONE			
OSC1&2			
⊖A knob	Wave	1 - 64	Select a Wavetable.
⊖B knob	Release	0 - 127	Adjust the release time. It can also be edited on AMP page. (→ P.68)
⊖C knob	Direction	1 - 16	Select the way that the Wavetable will be scanned.
⊖D knob	Speed	0 - 127	Adjust the speed at which the Wavetable will be scanned.
⬇B (Push)	End	0 - 127	Adjust the end point of Wavetable scanning
⬇C (Push)	Start	0 - 127	Adjust the start point of Wavetable scanning
⬇D (Push)	Curve	-63 - 63	Adjust the curve of the speed of Wavetable scanning

# Structure List







---

## SD TONE

Noise			
Ⓐ knob	Type	White, Pink, Brown, Purple, RESO	Select the Noise type.
Ⓑ knob	Frequency	0 - 127	Adjust the peak frequency of RESO Noise.
Ⓒ knob	Level	0 - 127	Adjust the level of Noise.
Ⓓ knob	Time	0 - 127	Adjust the length of time of the noise.

# Structure List

## SD TONE

SND			
 A knob	Decay	0 - 127	Adjust the decay time of OSC1.
 B knob	Balance	63 - 63	Adjust the volume balance between OSC1 and 2.
 C knob	Tune	-1200 - 1200	Adjust the OSC tuning.
 D knob	Retrigger	ON, OFF	When ON, the Wavetable is re-scanned each time a note is played.
 A (Push)	Tone	0 - 127	Adjust the tone of the dedicated High-Pass Filter connected to the Noise module.
 B (Push)	LP-F	0 - 127	Adjust the cutoff frequency of the dedicated Low-Pass Filter connected to the Noise module.
 D (Push)	LP-Q	0 - 127	Adjust the resonance (Q) of the dedicated Low-Pass Filter connected to the Noise module.

# Structure List

## RS STANDARD

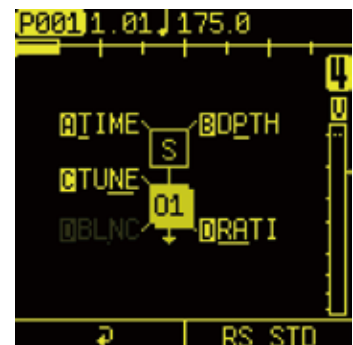
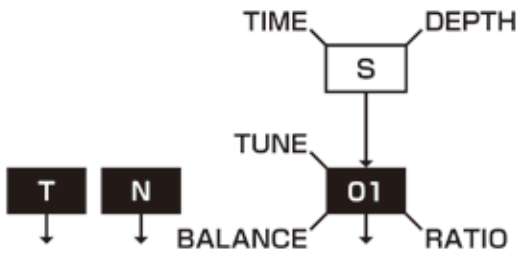

This is a Rim Shot structure that features a sub-oscillator.

The Ratio circuit adjusts the pitch of the sub-oscillator, and Balance adjusts the volume level balance between the sub-oscillator and the OSC.

The Sweep module has a dedicated high-speed sweep time.

RS STANDARD			
OSC			
Ⓐ knob	Wave	1 - 64	Select a Wavetable.
Ⓑ knob	Release	0 - 127	Adjust the release time. It can also be edited on AMP page. (→ P.68)
Ⓒ knob	Direction	1 - 16	Select the way that the Wavetable will be scanned.
Ⓓ knob	Speed	0 - 127	Adjust the speed at which the Wavetable will be scanned.
ⓑ (Push)	End	0 - 127	Adjust the end point of Wavetable scanning
ⓒ (Push)	Start	0 - 127	Adjust the start point of Wavetable scanning
ⓓ (Push)	Curve	-63 - 63	Adjust the curve of the speed of Wavetable scanning

# Structure List

## RS STANDARD

Noise			
Ⓐ knob	Type	White, Pink, Brown, Purple, RESO	Select the Noise type.
Ⓑ knob	Frequency	0 - 127	Adjust the peak frequency of RESO Noise.
Ⓒ knob	Level	0 - 127	Adjust the level of Noise.
Ⓓ knob	Time	0 - 127	Adjust the length of time of the noise.
Tick			
Ⓐ knob	Pulse	Pulse, H-Saw, Rectangle, F-saw, Cheb, Sine, Gaus, Rapid, Hi-F, Noise	Select the type of Pulse.
Ⓑ knob	Time	0 - 127	Adjust the length of time of the Pulse.
Ⓒ knob	Volume	0 - 127	Adjust the level of the Pulse.

# Structure List

## RS STANDARD

SND			
Ⓐ knob	Sweep Time1	Down63 - OFF - Up63	<b>Adjust the time of the pitch sweep modulation of OSC1.</b> The lower the value, the faster the sweep speed.
Ⓑ knob	Sweep Depth1	-63 - 63	<b>Adjust the amount of pitch sweep of OSC1.</b> DOWN makes the pitch sweep down. UP makes it sweep up. The higher the value, the more the pitch sweeps up or down.
Ⓒ knob	Tune	-1200 - 1200	Adjust the OSC tuning.
Ⓓ knob	Balance	-63 - 63	Adjust the volume balance between OSC1 and the sub-oscillator.
Ⓔ D (Push)	Ratio	0 - 127	<b>Adjust the pitch ratio of the sub oscillator to OSC1</b> When set to 10, the ratio is 2:1.

# Structure List

## CP STANDARD

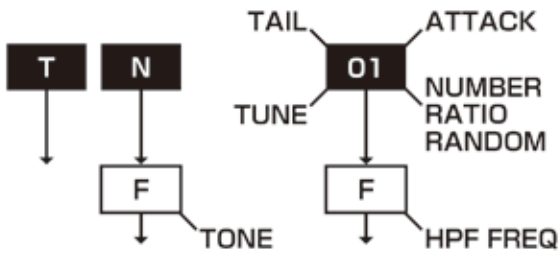

This is a Clap structure inspired by classic 80s drum machines.

Synthesis is performed with an OSC that uses noise as a pitch modulation source and a multi-triggered amp envelope that can recreate clap sounds.

The tone of the Noise module can be adjusted with the dedicated Filter module.

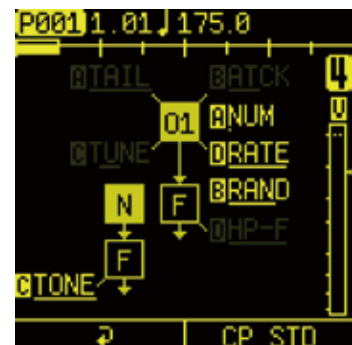

CP STANDARD			
OSC			
⊖A knob	Wave	1 - 64	Select a Wavetable.
⊖B knob	Release	0 - 127	Adjust the release time. It can also be edited on AMP page. (→ P.68)
⊖C knob	Direction	1 - 16	Select the way that the Wavetable will be scanned.
⊖D knob	Speed	0 - 127	Adjust the speed at which the Wavetable will be scanned.
⬇B (Push)	End	0 - 127	Adjust the end point of Wavetable scanning
⬇C (Push)	Start	0 - 127	Adjust the start point of Wavetable scanning
⬇D (Push)	Curve	-63 - 63	Adjust the curve of the speed of Wavetable scanning









# Structure List

## CP STANDARD

Noise			
Ⓐ knob	Type	White, Pink, Brown, Purple, RESO	Select the Noise type.
Ⓑ knob	Frequency	0 - 127	Adjust the peak frequency of RESO Noise.
Ⓒ knob	Level	0 - 127	Adjust the level of Noise.
Ⓓ knob	Time	0 - 127	Adjust the length of time of the noise.
Tick			
Ⓐ knob	Pulse	Pulse, H-Saw, Rectangle, F-saw, Cheb, Sine, Gaus, Rapid, Hi-F, Noise	Select the type of Pulse.
Ⓑ knob	Time	0 - 127	Adjust the length of time of the Pulse.
Ⓒ knob	Volume	0 - 127	Adjust the level of the Pulse.

# Structure List

## CP STANDARD

SND			
 A knob	Tail	0 - 127	<b>Adjust the clap release time.</b> The higher the value, the longer the tail of the sound will decay.
 B knob	Attack	-63 - 63	<b>Adjust the overall attack of the clap.</b> The higher the value, the softer the attack.
 C knob	Tune	-1200 - 1200	Adjust the OSC tuning.
 D knob	Rate	0 - 127	<b>Adjust the interval rate between clap sounds.</b> The lower the value, the shorter the interval.
 A (Push)	Number	0 - 127	<b>Adjust the number of clap sounds.</b> When set to 0, one clap sound will be produced. The higher the value, the more clap sounds will be produced.
 B (Push)	Random	0 - 127	<b>Adjust the randomization of the timing of clap sounds.</b> The higher the value, the more the timing will be randomized.
 C (Push)	Tone	0 - 127	Adjust the tone of the dedicated High-Pass Filter connected to the Noise module.
 D (Push)	HP-F	0 - 127	Adjust the cutoff frequency of the High-Pass Filter connected to OSC1.

# Structure List

## TT STANDARD

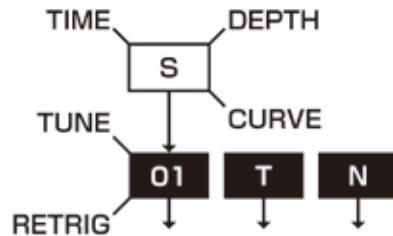

This is a basic Tom-Tom drum structure. Synthesis is performed by applying pitch sweep modulation to the OSC. Noise and Tick modules are combined to create a transient sound with a sense of attack.

TT STANDARD			
OSC			
Ⓐ knob	Wave	1 - 64	Select a Wavetable.
Ⓑ knob	Release	0 - 127	Adjust the release time. It can also be edited on AMP page. (→ P.68)
Ⓒ knob	Direction	1 - 16	Select the way that the Wavetable will be scanned.
Ⓓ knob	Speed	0 - 127	Adjust the speed at which the Wavetable will be scanned.
ⓑ (Push)	End	0 - 127	Adjust the end point of Wavetable scanning
ⓒ (Push)	Start	0 - 127	Adjust the start point of Wavetable scanning
ⓓ (Push)	Curve	-63 - 63	Adjust the curve of the speed of Wavetable scanning

# Structure List

## TT STANDARD

Noise			
⊞A knob	Type	White, Pink, Brown, Purple, RESO	Select the Noise type.
⊞B knob	Frequency	0 - 127	Adjust the peak frequency of RESO Noise.
⊞C knob	Level	0 - 127	Adjust the level of Noise.
⊞D knob	Time	0 - 127	Adjust the length of time of the noise.
Tick			
⊞A knob	Pulse	Pulse, H-Saw, Rectangle, F-saw, Cheb, Sine, Gaus, Rapid, Hi-F, Noise	Select the type of Pulse.
⊞B knob	Time	0 - 127	Adjust the length of time of the Pulse.
⊞C knob	Volume	0 - 127	Adjust the level of the Pulse.

# Structure List

## TT STANDARD

SND			
⊗A knob	Sweep Time	0 - 127	<b>Adjust the time of the pitch sweep modulation.</b> The lower the value, the faster the sweep speed.
⊗B knob	Sweep Depth	Down63 - OFF - Up63	<b>Adjust the amount of pitch sweep.</b> DOWN makes the pitch sweep down. UP makes it sweep up. The higher the value, the more the pitch sweeps up or down.
⊗C knob	Tune	-1200 - 1200	Adjust the OSC tuning.
⊗D knob	Sweep Curve	-63 - 63	<b>Adjust the curve of the pitch sweep.</b> Negative values create a LOG curve. Positive values create an EXP curve.
⬇D (Push)	Retrigger	ON, OFF	When ON, the Wavetable is re-scanned each time a note is played.

# Structure List

## PC STANDARD

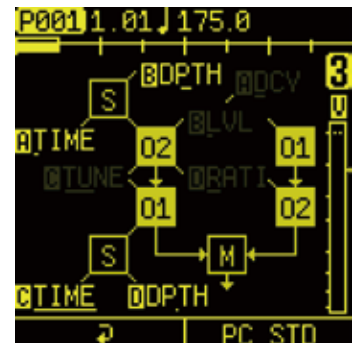
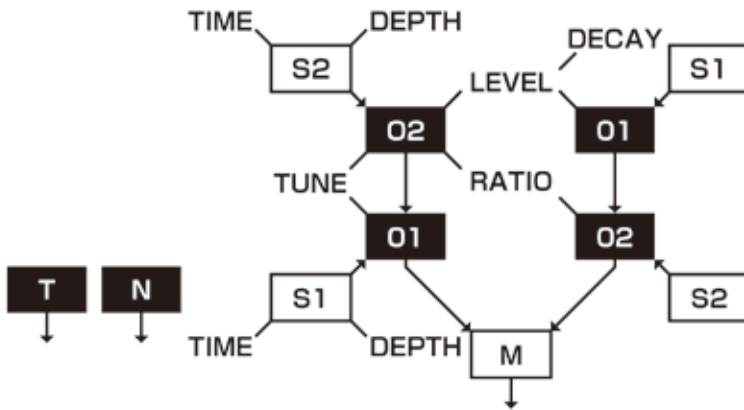

This is a Percussion structure that combines ring modulation and FM synthesis.

Applying ring modulation to two FM OSC groups, it recreates the textures of percussive sounds, such as metallic and leather drumhead-style overtones.

Level and Decay adjust the amount of FM applied to the carrier OSC, and Ratio adjusts the pitch ratio of OSC2.

PC STANDARD			
OSC1&2			
⊖A knob	Wave	1 - 64	Select a Wavetable.
⊖B knob	Release	0 - 127	Adjust the release time. It can also be edited on AMP page. (→ P.68)
⊖C knob	Direction	1 - 16	Select the way that the Wavetable will be scanned.
⊖D knob	Speed	0 - 127	Adjust the speed at which the Wavetable will be scanned.
⬇B (Push)	End	0 - 127	Adjust the end point of Wavetable scanning
⬇C (Push)	Start	0 - 127	Adjust the start point of Wavetable scanning
⬇D (Push)	Curve	-63 - 63	Adjust the curve of the speed of Wavetable scanning

# Structure List

## PC STANDARD

Noise			
⊞A knob	Type	White, Pink, Brown, Purple, RESO	Select the Noise type.
⊞B knob	Frequency	0 - 127	Adjust the peak frequency of RESO Noise.
⊞C knob	Level	0 - 127	Adjust the level of Noise.
⊞D knob	Time	0 - 127	Adjust the length of time of the noise.
Tick			
⊞A knob	Pulse	Pulse, H-Saw, Rectangle, F-saw, Cheb, Sine, Gaus, Rapid, Hi-F, Noise	Select the type of Pulse.
⊞B knob	Time	0 - 127	Adjust the length of time of the Pulse.
⊞C knob	Volume	0 - 127	Adjust the level of the Pulse.

# Structure List

## PC STANDARD

SND			
Ⓐ knob	Decay	0 - 127	Adjust the decay time of the level parameter.
Ⓑ knob	Level	0 - 127	Adjust the amount of modulation of OSC2.
Ⓒ knob	Tune	-1200 - 1200	Adjust the OSC tuning.
Ⓓ knob	Ratio	0 - 127	<b>Adjust the pitch ratio of OSC2 to OSC1</b> When set to 10, the ratio is 1:1.
Ⓐ (Push)	Sweep Time2	Down63 - OFF - Up63	<b>Adjust the time of the pitch sweep modulation of OSC2.</b> The lower the value, the faster the sweep speed.
Ⓑ (Push)	Sweep Depth2	-63 - 63	<b>Adjust the amount of pitch sweep of OSC2.</b> DOWN makes the pitch sweep down. UP makes it sweep up. The higher the value, the more the pitch sweeps up or down.
Ⓒ (Push)	Sweep Time1	Down63 - OFF - Up63	<b>Adjust the time of the pitch sweep modulation of OSC1.</b> The lower the value, the faster the sweep speed.
Ⓓ (Push)	Sweep Depth1	-63 - 63	<b>Adjust the amount of pitch sweep of OSC1.</b> DOWN makes the pitch sweep down. UP makes it sweep up. The higher the value, the more the pitch sweeps up or down.



# Structure List

## PC COWBEL

Noise			
Ⓐ knob	Type	White, Pink, Brown, Purple, RESO	Select the Noise type.
Ⓑ knob	Frequency	0 - 127	Adjust the peak frequency of RESO Noise.
Ⓒ knob	Level	0 - 127	Adjust the level of Noise.
Ⓓ knob	Time	0 - 127	Adjust the length of time of the noise.
Tick			
Ⓐ knob	Pulse	Pulse, H-Saw, Rectangle, F-saw, Cheb, Sine, Gaus, Rapid, Hi-F, Noise	Select the type of Pulse.
Ⓑ knob	Time	0 - 127	Adjust the length of time of the Pulse.
Ⓒ knob	Volume	0 - 127	Adjust the level of the Pulse.

# Structure List

## PC COWBEL

SND			
⊗A knob	Balance	-63 - 63	Adjust the volume balance between OSC1 and 2.
⊗B knob	Ratio	0 - 127	<b>Adjust the pitch ratio of OSC2 to OSC1.</b> When set to 0, the ratio is 1:1.
⊗C knob	Tune	-1200 - 1200	Adjust the OSC tuning.
⊗D knob	Metallic	0 - 127	<b>Adjust the amount of metallic overtones.</b> The higher the value, the more overtones will be added.
⬇ D (Push)	HP-F	0 - 127	Adjust the cutoff frequency of the dedicated High-Pass Filter applied to the modulated signal.

# Structure List

## SY STANDARD

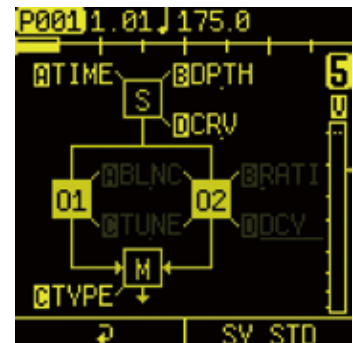
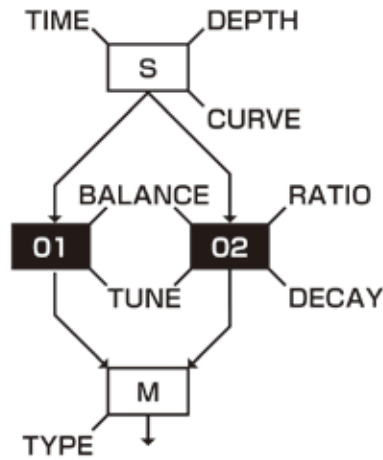

This is a Synthesizer structure that performs standard subtractive synthesis with two OSCs.

The Ratio and Decay circuits set the pitch and decay time of OSC2 relative to OSC1.

The modulation module can mix the two OSCs, or it can perform FM or ring modulation.

SY STANDARD			
OSC1&2			
ⓂA knob	Wave	1 - 64	Select a Wavetable.
ⓂB knob	Release	0 - 127	Adjust the release time. It can also be edited on AMP page. (→ P.68)
ⓂC knob	Direction	1 - 16	Select the way that the Wavetable will be scanned.
ⓂD knob	Speed	0 - 127	Adjust the speed at which the Wavetable will be scanned.
ⓂB (Push)	End	0 - 127	Adjust the end point of Wavetable scanning
ⓂC (Push)	Start	0 - 127	Adjust the start point of Wavetable scanning
ⓂD (Push)	Curve	-63 - 63	Adjust the curve of the speed of Wavetable scanning

# Structure List

## SY STANDARD

SND			
⊖ A knob	Balance	0 - 127	Adjust the balance between OSC1 and 2
⊖ B knob	Ratio	0 - 127	<b>Adjust the pitch ratio of OSC2 to OSC1</b> When set to 10, the ratio is 1:1.
⊖ C knob	Tune	-1200 - 1200	Adjust the OSC tuning.
⊖ D knob	Decay	0 - 127	Adjust the decay time of OSC2.
⬇ A (Push)	Sweep Time	Down63 - OFF - Up63	<b>Adjust the time of the pitch sweep modulation.</b> The lower the value, the faster the sweep speed.
⬇ B (Push)	Sweep Depth	-63 - 63	<b>Adjust the amount of pitch sweep.</b> DOWN makes the pitch sweep down. UP makes it sweep up. The higher the value, the more the pitch sweeps up or down.
⬇ C (Push)	Mod Type	MIX, RM, FM	Select the type of modulation. <b>MIX</b> Sum OSC1 and OSC2. Balance adjusts the volume balance between the two. <b>RM</b> Ring modulate OSC1 with OSC2. Balance adjusts the amount of modulation. <b>FM</b> Perform FM with OSC1 as carrier and OSC2 as modulator. Balance adjusts the amount of modulation.
⬇ D (Push)	Sweep Curve	-63 - 63	<b>Adjust the curve of the pitch sweep.</b> Negative values create a LOG curve. Positive values create an EXP curve.

# Structure List

## SY BASS

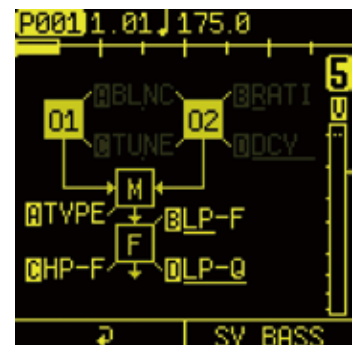
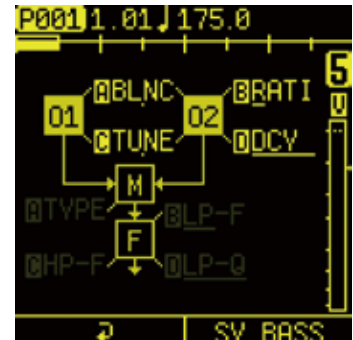
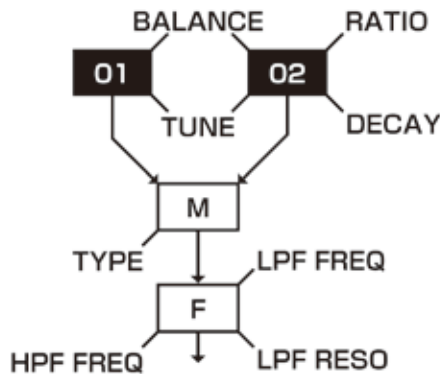

This is a Bass Synthesizer structure with two OSCs.

The Ratio and Decay circuits set the pitch and decay time of OSC2 relative to OSC1.

The modulation module can mix the two OSCs, or it can perform FM or ring modulation.

The dedicated Low-Pass Filter reproduces the characteristics of a 3-pole ladder filter, making it ideal for creating acid bass lines.

SY BASS			
OSC1&2			
Ⓐ knob	Wave	1 - 64	Select a Wavetable.
Ⓑ knob	Release	0 - 127	Adjust the release time. It can also be edited on AMP page. (→ P.68)
Ⓒ knob	Direction	1 - 16	Select the way that the Wavetable will be scanned.
Ⓓ knob	Speed	0 - 127	Adjust the speed at which the Wavetable will be scanned.
Ⓔ B (Push)	End	0 - 127	Adjust the end point of Wavetable scanning
Ⓕ C (Push)	Start	0 - 127	Adjust the start point of Wavetable scanning
Ⓖ D (Push)	Curve	-63 - 63	Adjust the curve of the speed of Wavetable scanning

# Structure List

## SY BASS

SND			
🕒 A knob	Balance	0 - 127	Adjust the balance between OSC1 and 2
🕒 B knob	Ratio	0 - 127	<b>Adjust the pitch ratio of OSC2 to OSC1</b> When set to 10, the ratio is 1:1.
🕒 C knob	Tune	-1200 - 1200	Adjust the OSC tuning.
🕒 D knob	Decay	0 - 127	Adjust the decay time of OSC2.
⏴ A (Push)	Mod Type	MIX, RM, FM	Select the type of modulation. <b>MIX</b> Sum OSC1 and OSC2. Balance adjusts the volume balance between the two. <b>RM</b> Ring modulate OSC1 with OSC2. Balance adjusts the amount of modulation. <b>FM</b> Perform FM with OSC1 as carrier and OSC2 as modulator. Balance adjusts the amount of modulation.
⏴ B (Push)	LP-F	0 - 127	Adjust the cutoff frequency of the dedicated Low-Pass Filter.
⏴ C (Push)	HP-F	0 - 127	Adjust the cutoff frequency of the dedicated High-Pass Filter.
⏴ D (Push)	LP-Q	0 - 127	Adjust the resonance (Q) of the dedicated Low-Pass Filter.

# Structure List

## AC STANDARD

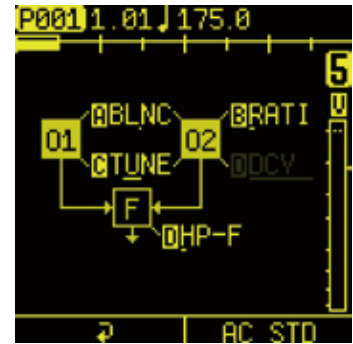
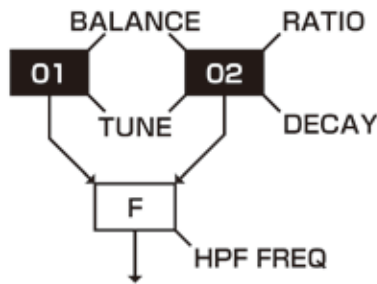

This is a special structure for creating Acoustic percussion sounds, featuring two OSCs. The OSCs are implemented with a slow scanning time suitable for playing acoustic Wavetables.

The harmonics and sound duration of OSC2 can be adjusted relative to OSC1 with the Ratio and Decay parameters, respectively.

A dedicated High-Pass Filter can cut the aliasing noises associated with slow Wavetable scanning.

SY BASS			
OSC1&2			
Ⓐ knob	Wave	1 - 64	Select a Wavetable.
Ⓑ knob	Release	0 - 127	Adjust the release time. It can also be edited on AMP page. (→ P.68)
Ⓒ knob	Direction	1 - 16	Select the way that the Wavetable will be scanned.
Ⓓ knob	Speed	0 - 127	Adjust the speed at which the Wavetable will be scanned.
ⓑ (Push)	End	0 - 127	Adjust the end point of Wavetable scanning
Ⓒ (Push)	Start	0 - 127	Adjust the start point of Wavetable scanning
Ⓓ (Push)	Curve	-63 - 63	Adjust the curve of the speed of Wavetable scanning

# Structure List

---

## AC STANDARD

SND			
⊗A knob	Balance	0 - 127	Adjust the volume balance between OSC1 and 2.
⊗B knob	Ratio	0 - 127	<b>Adjust the pitch ratio of OSC2 to OSC1</b> When set to 10, the ratio is 1:1.
⊗C knob	Tune	-1200 - 1200	Adjust the OSC tuning.
⊗D knob	Decay	0 - 127	Adjust the decay time of OSC2.
⊕ C (Push)	HPF Frequency	0 - 127	Adjust the cutoff frequency of the dedicated High-Pass Filter.

# Structure List

## CH STANDARD

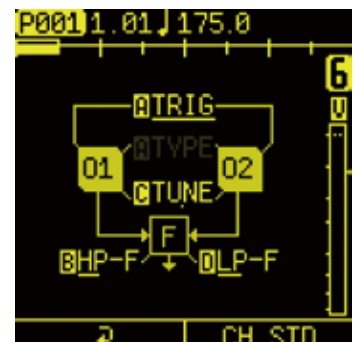
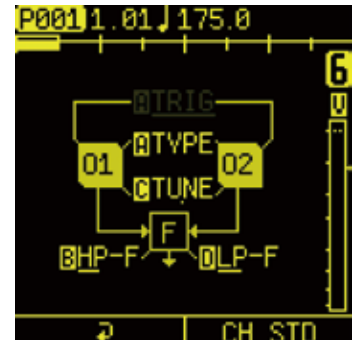
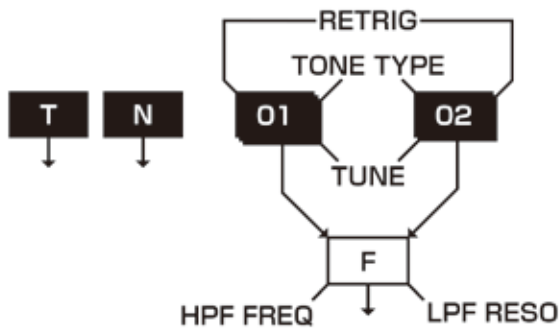

This is a standard Closed Hi-Hat structure with two OSCs.

OSC1 has two sub-oscillators and OSC2 has one. Synthesis can be adjusted through a dedicated High-Pass Filter and Low-Pass Filter that are connected in parallel to the oscillator bank.

Changing the Tone Type alters the metallic texture of the sound.

CH STANDARD			
OSC1&2			
Ⓐ knob	Wave	1 - 64	Select a Wavetable.
Ⓑ knob	Release	0 - 127	Adjust the release time. It can also be edited on AMP page. (→ P.68)
Ⓒ knob	Direction	1 - 16	Select the way that the Wavetable will be scanned.
Ⓓ knob	Speed	0 - 127	Adjust the speed at which the Wavetable will be scanned.
ⓑ (Push)	End	0 - 127	Adjust the end point of Wavetable scanning
ⓒ (Push)	Start	0 - 127	Adjust the start point of Wavetable scanning
ⓓ (Push)	Curve	-63 - 63	Adjust the curve of the speed of Wavetable scanning

# Structure List

## CH STANDARD

Noise			
Ⓐ knob	Type	White, Pink, Brown, Purple, RESO	Select the Noise type.
Ⓑ knob	Frequency	0 - 127	Adjust the peak frequency of RESO Noise.
Ⓒ knob	Level	0 - 127	Adjust the level of Noise.
Ⓓ knob	Time	0 - 127	Adjust the length of time of the noise.
Tick			
Ⓐ knob	Pulse	Hi-F, Noise	Select the type of Pulse.
Ⓑ knob	Time	0 - 127	Adjust the length of time of the Pulse.
Ⓒ knob	Volume	0 - 127	Adjust the level of the Pulse.

# Structure List

## CH STANDARD

SND			
🔊 A knob	Tone Type	GOLD, SILVER, BRONZE, TIN, COPPER, STEEL, IRON, NICKEL, ZINC, BRASS	<b>Change the tone type.</b> Switching between tone types will vary the pitch ratio of the OSC bank.
🔊 B knob	HP-F	0 - 127	Adjust the cutoff frequency of the dedicated High-Pass Filter applied to OSC1 and 2.
🔊 C knob	Tune	-1200 - 1200	Adjust the OSC tuning.
🔊 D knob	LP-F	0 - 127	Adjust the cutoff frequency of the dedicated Low-Pass Filter applied to OSC1 and 2.
👇 A (Push)	Retrigger	ON, OFF	Set whether the Wavetable is re-scanned each time a note is played.

# Structure List

## CH METALLIC

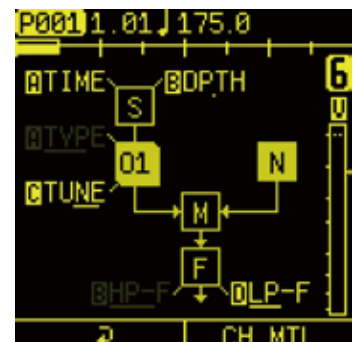
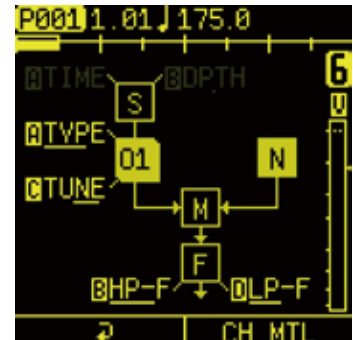
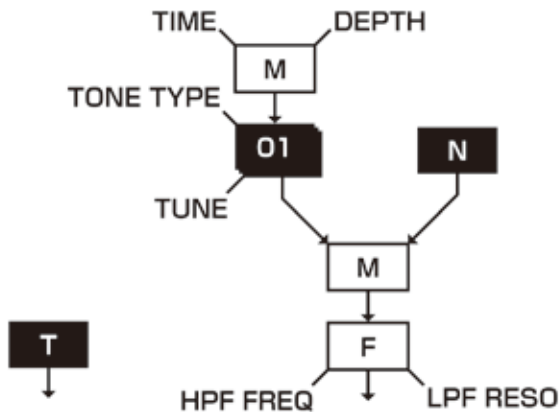

This is a Closed Hi-Hat structure that uses ring modulation to create metallic sonic textures.

A noise module applies ring modulation to an OSC bank, which consists of OSC1 and two sub-oscillators. A dedicated High-Pass and Low-Pass Filter are connected in parallel and applied to the modulated signal.

You can adjust the amount of ring modulation by changing the parameters of the Noise module, and you can adjust the metallic texture of the sound by changing the Tone Type.

CH METALLIC			
OSC			
⊖A knob	Wave	1 - 64	Select a Wavetable.
⊖B knob	Release	0 - 127	Adjust the release time. It can also be edited on AMP page. (→ P.68)
⊖C knob	Direction	1 - 16	Select the way that the Wavetable will be scanned.
⊖D knob	Speed	0 - 127	Adjust the speed at which the Wavetable will be scanned.
⬇B (Push)	End	0 - 127	Adjust the end point of Wavetable scanning
⬇C (Push)	Start	0 - 127	Adjust the start point of Wavetable scanning
⬇D (Push)	Curve	-63 - 63	Adjust the curve of the speed of Wavetable scanning

# Structure List

## CH METALLIC

Noise			
⊞A knob	Type	White, Pink, Brown, Purple, RESO	Select the Noise type.
⊞B knob	Frequency	0 - 127	Adjust the peak frequency of RESO Noise.
⊞C knob	Level	0 - 127	Adjust the level of Noise.
⊞D knob	Time	0 - 127	Adjust the length of time of the noise.
Tick			
⊞A knob	Pulse	Hi-F, Noise	Select the type of Pulse.
⊞B knob	Time	0 - 127	Adjust the length of time of the Pulse.
⊞C knob	Volume	0 - 127	Adjust the level of the Pulse.

# Structure List

## CH METALLIC

SND			
🔊A knob	Tone Type	GOLD, SILVER, BRONZE, TIN, COPPER, STEEL, IRON, NICKEL, ZINC, BRASS	<b>Chang the tone type</b> Changing the tone type will make the pitch ratio in the osc bank vary.
🔊B knob	HP-F	0 - 127	Adjust the dedicated High-Pass filter frequency connected to the modulated signal.
🔊C knob	Tune	-1200 - 1200	Adjust the OSC tuning.
🔊D knob	LP-F	0 - 127	Adjust the dedicated Low-Pass filter frequency connected to the modulated signal.
⬇️ A (Push)	Sweep Depth	Down63 - OFF - Up63	<b>Adjust the amount of pitch sweep.</b> DOWN makes the pitch sweep down. UP makes it sweep up. The higher the value, the more the pitch sweeps up or down.
⬇️ B (Push)	Sweep Time	0 - 127	<b>Adjust the time of the pitch sweep modulation.</b> The lower the value, the faster the sweep speed.

# Structure List

## CH CLASSIC

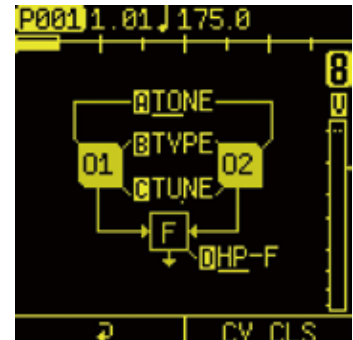
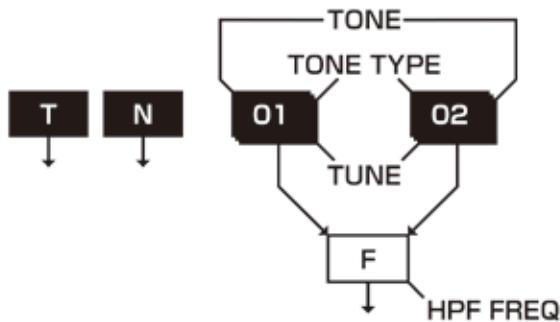

This is a Closed High-Hat structure inspired by classic 80s drum machines.

Synthesis is performed by adjusting the dedicated High-Pass and Low-Pass Filter that are connected in parallel to an oscillator bank that has two sub-oscillators in each OSC.

By changing the Tone Type, you can change the metallic texture of the sound.

CH CLASSIC			
OSC1&2			
Ⓐ knob	Wave	1 - 64	Select a Wavetable.
Ⓑ knob	Release	0 - 127	Adjust the release time. It can also be edited on AMP page. (→ P.68)
Ⓒ knob	Direction	1 - 16	Select the way that the Wavetable will be scanned.
Ⓓ knob	Speed	0 - 127	Adjust the speed at which the Wavetable will be scanned.
ⓑ (Push)	End	0 - 127	Adjust the end point of Wavetable scanning
ⓒ (Push)	Start	0 - 127	Adjust the start point of Wavetable scanning
ⓓ (Push)	Curve	-63 - 63	Adjust the curve of the speed of Wavetable scanning

# Structure List

## CH CLASSIC

Noise			
⊞A knob	Type	White, Pink, Brown, Purple, RESO	Select the Noise type.
⊞B knob	Frequency	0 - 127	Adjust the peak frequency of RESO Noise.
⊞C knob	Level	0 - 127	Adjust the level of Noise.
⊞D knob	Time	0 - 127	Adjust the length of time of the noise.
Tick			
⊞A knob	Pulse	Hi-F, Noise	Select the type of Pulse.
⊞B knob	Time	0 - 127	Adjust the length of time of the Pulse.
⊞C knob	Volume	0 - 127	Adjust the level of the Pulse.

# Structure List

## CH CLASSIC

SND			
Ⓐ knob	Tone Type	GOLD, SILVER, BRONZE, TIN, COPPER, STEEL, IRON, NICKEL, ZINC, BRASS	<b>Change the tone type</b> Switching between tone types will vary the pitch ratio of the OSC bank.
Ⓑ knob	Tone	0 - 127	Adjust the frequency of the dedicated Band Pass Filter that is built in to the OSC bank.
Ⓒ knob	Tune	-1200 - 1200	Adjust the OSC tuning.
Ⓓ knob	HP-F	0 - 127	Adjust the cutoff frequency of the dedicated High-Pass Filter applied to OSC1 and 2.

# Structure List

## OH STANDARD

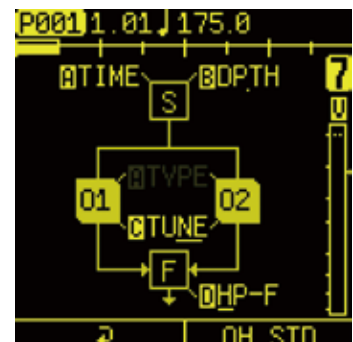
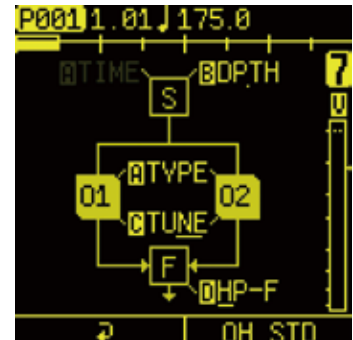
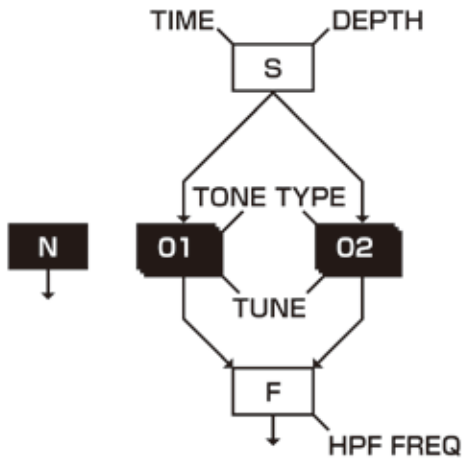

This is a standard Open Hi-hat structure. Synthesis is performed by adjusting a dedicated High-Pass Filter that is connected in parallel to an oscillator bank with two sub-oscillators in each OSC. By changing the Tone Type, you can change the metallic texture of the sound.

OH STANDARD			
OSC1&2			
Ⓐ knob	Wave	1 - 64	Select a Wavetable.
Ⓑ knob	Release	0 - 127	Adjust the release time. It can also be edited on AMP page. (→ P.68)
Ⓒ knob	Direction	1 - 16	Select the way that the Wavetable will be scanned.
Ⓓ knob	Speed	0 - 127	Adjust the speed at which the Wavetable will be scanned.
ⓑ (Push)	End	0 - 127	Adjust the end point of Wavetable scanning
ⓒ (Push)	Start	0 - 127	Adjust the start point of Wavetable scanning
ⓓ (Push)	Curve	-63 - 63	Adjust the curve of the speed of Wavetable scanning

# Structure List

## OH STANDARD

Noise			
Ⓐ knob	Type	White, Pink, Brown, Purple, RESO	Select the Noise type.
Ⓑ knob	Frequency	0 - 127	Adjust the peak frequency of RESO Noise.
Ⓒ knob	Level	0 - 127	Adjust the level of Noise.
Ⓓ knob	Time	0 - 127	Adjust the length of time of the noise.
Tick			
Ⓐ knob	Pulse	Hi-F, Noise	Select the type of Pulse.
Ⓑ knob	Time	0 - 127	Adjust the length of time of the Pulse.
Ⓒ knob	Volume	0 - 127	Adjust the level of the Pulse.

# Structure List

## OH STANDARD

SND			
Ⓐ knob	Tone Type	GOLD, SILVER, BRONZE, TIN, COPPER, STEEL, IRON, NICKEL, ZINC, BRASS	<b>Chang the tone type</b> Switching between tone types will vary the pitch ratio of the OSC bank.
Ⓑ knob	Metallic	0 - 127	<b>Adjust the amount of metallic overtones</b> The higher the value, the more overtones will be added.
Ⓒ knob	Tune	-1200 - 1200	Adjust the OSC tuning.
Ⓓ knob	HP-F	0 - 127	Adjust the cutoff frequency of the dedicated High-Pass Filter applied to the modulated signal.
Ⓐ (Push)	Sweep Time1	0 - 127	<b>Adjust the time of the pitch sweep modulation of OSC1.</b> The lower the value, the faster the sweep speed.
Ⓑ (Push)	Sweep Depth1	Down63 - OFF - Up63	<b>Adjust the amount of pitch sweep of OSC1.</b> DOWN makes the pitch sweep down. UP makes it sweep up. The higher the value, the more the pitch sweeps up or down.
Ⓓ (Push)	LP-F	0 - 127	Adjust the cutoff frequency of the dedicated Low-Pass Filter applied to the modulated signal.

# Structure List

## OH METALLIC

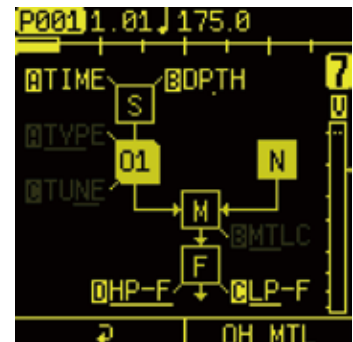
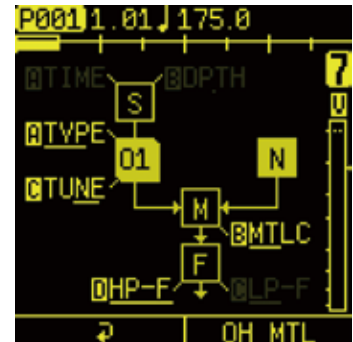
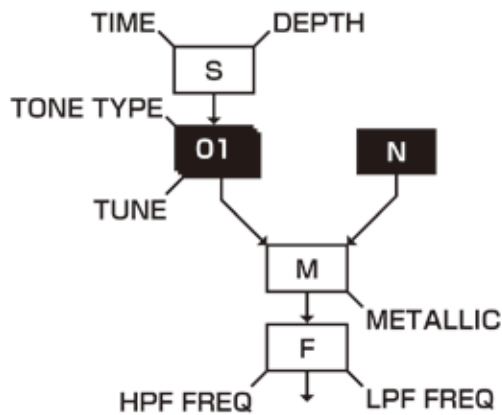

This is an Open Hi-Hat structure that uses ring modulation to create a metallic sound. The oscillator bank has two sub-oscillators. Ring modulation is provided by the Noise module. Dedicated High-Pass and Low-Pass Filters are applied to the modulated signal.

The amount of ring modulation can be adjusted by changing the parameters of the NOISE module.

You can adjust the Metallic parameter to add metallic overtones to the sound and change the Tone Type to change the texture of the overtones.

OH METALLIC			
OSC			
ⓂA knob	Wave	1 - 64	Select a Wavetable.
ⓂB knob	Release	0 - 127	Adjust the release time. It can also be edited on AMP page. (→ P.68)
ⓂC knob	Direction	1 - 16	Select the way that the Wavetable will be scanned.
ⓂD knob	Speed	0 - 127	Adjust the speed at which the Wavetable will be scanned.
ⓂB (Push)	End	0 - 127	Adjust the end point of Wavetable scanning
ⓂC (Push)	Start	0 - 127	Adjust the start point of Wavetable scanning
ⓂD (Push)	Curve	-63 - 63	Adjust the curve of the speed of Wavetable scanning

# Structure List

---

## OH METALLIC

Noise			
Ⓐ knob	Type	White, Pink, Brown, Purple, RESO	Select the Noise type.
Ⓑ knob	Frequency	0 - 127	Adjust the peak frequency of RESO Noise.
Ⓒ knob	Level	0 - 127	Adjust the level of Noise.
Ⓓ knob	Time	0 - 127	Adjust the length of time of the noise.

# Structure List

## OH METALLIC

SND			
🔊A knob	Tone Type	GOLD, SILVER, BRONZE, TIN, COPPER, STEEL, IRON, NICKEL, ZINC, BRASS	<b>Change the tone type.</b> Switching between tone types will vary the pitch ratio of the OSC bank.
🔊B knob	Metallic	0 - 127	<b>Adjust the amount of metallic overtones</b> The higher the value, the more overtones will be added.
🔊C knob	Tune	-1200 - 1200	Adjust the OSC tuning.
🔊D knob	HP-F	0 - 127	Adjust the cutoff frequency of the dedicated High-Pass filter applied to the modulated signal.
⬇️ A (Push)	Sweep Time1	0 - 127	<b>Adjust the time of the pitch sweep modulation of OSC1.</b> The lower the value, the faster the sweep speed.
⬇️ B (Push)	Sweep Depth1	Down63 - OFF - Up63	<b>Adjust the amount of pitch sweep of OSC1.</b> DOWN makes the pitch sweep down. UP makes it sweep up. The higher the value, the more the pitch sweeps up or down.
⬇️ D (Push)	LP-F	0 - 127	Adjust the cutoff frequency of the dedicated Low-Pass Filter applied to the modulated signal.

# Structure List

## CY STANDARD

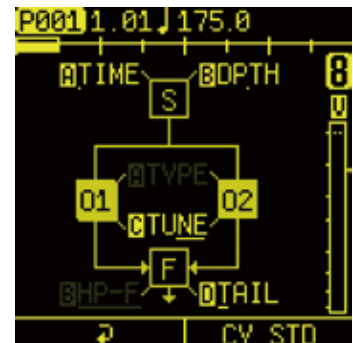
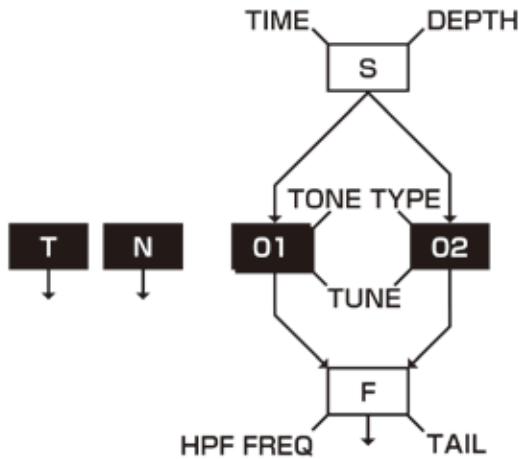

This is a standard Cymbal structure. Synthesis is performed by adjusting a dedicated High-Pass and Low-Pass Filter that are connected in parallel to an Oscillator bank that has one sub-oscillator in OSC1. By adjusting the envelope with Tail, the Low-Pass Filter recreates a sizzle-like sound. Changing the Tone Type alters the texture of the metallic sound.

CY STANDARD			
OSC1&2			
ⓂA knob	Wave	1 - 64	Select a Wavetable.
ⓂB knob	Release	0 - 127	Adjust the release time. It can also be edited on AMP page. (→ P.68)
ⓂC knob	Direction	1 - 16	Select the way that the Wavetable will be scanned.
ⓂD knob	Speed	0 - 127	Adjust the speed at which the Wavetable will be scanned.
ⓂB (Push)	End	0 - 127	Adjust the end point of Wavetable scanning
ⓂC (Push)	Start	0 - 127	Adjust the start point of Wavetable scanning
ⓂD (Push)	Curve	-63 - 63	Adjust the curve of the speed of Wavetable scanning

# Structure List

## CY STANDARD

Noise			
Ⓐ knob	Type	White, Pink, Brown, Purple, RESO	Select the Noise type.
Ⓑ knob	Frequency	0 - 127	Adjust the peak frequency of RESO Noise.
Ⓒ knob	Level	0 - 127	Adjust the level of Noise.
Ⓓ knob	Time	0 - 127	Adjust the length of time of the noise.
Tick			
Ⓐ knob	Pulse	Hi-F, Noise	Select the type of Pulse.
Ⓑ knob	Time	0 - 127	Adjust the length of time of the Pulse.
Ⓒ knob	Volume	0 - 127	Adjust the level of the Pulse.

# Structure List

## CY STANDARD

SND			
🔊A knob	Tone Type	GOLD, SILVER, BRONZE, TIN, COPPER, STEEL, IRON, NICKEL, ZINC, BRASS	<b>Change the tone type.</b> Switching between tone types will vary the pitch ratio of the OSC bank.
🔊B knob	HP-F	0 - 127	Adjust the cutoff frequency of the dedicated High-Pass Filter applied to the OSC bank.
🔊C knob	Tune	-1200 - 1200	Adjust the OSC tuning.
🔊D knob	Tail	0 - 127	<b>Adjust the envelope tail of the Low-Pass Filter.</b> The higher the value, the quicker the filter's cutoff closes.
👇 A (Push)	Sweep Time1	Down63 - OFF - Up63	<b>Adjust the time of the pitch sweep modulation of OSC1.</b> The lower the value, the faster the sweep speed.
🔊B knob	Sweep Depth1	-63 - 63	<b>Adjust the amount of pitch sweep of OSC1.</b> DOWN makes the pitch sweep down. UP makes it sweep up. The higher the value, the more the pitch sweeps up or down.

# Structure List

## CY CLASSIC

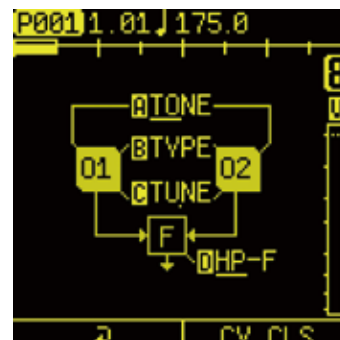
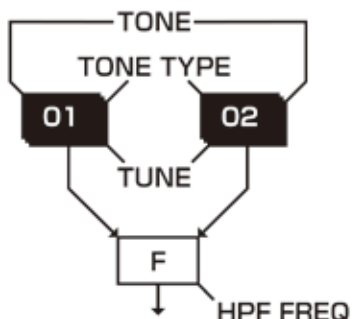

This is a Cymbal structure inspired by classic 80s drum machines.

Synthesis is performed by adjusting a dedicated Band-Pass and High-Pass Filter that are connected in parallel to an oscillator bank with two sub-oscillators for each OSC. By adjusting the Tone Type, you can switch between different metallic sound textures.

CY CLASSIC			
OSC1&2			
Ⓐ knob	Wave	1 - 64	Select a Wavetable.
Ⓑ knob	Release	0 - 127	Adjust the release time. It can also be edited on AMP page. (→ P.68)
Ⓒ knob	Direction	1 - 16	Select the way that the Wavetable will be scanned.
Ⓓ knob	Speed	0 - 127	Adjust the speed at which the Wavetable will be scanned.
ⓑ (Push)	End	0 - 127	Adjust the end point of Wavetable scanning
ⓒ (Push)	Start	0 - 127	Adjust the start point of Wavetable scanning
ⓓ (Push)	Curve	-63 - 63	Adjust the curve of the speed of Wavetable scanning

# Structure List

## CY CLASSIC

SND			
ⓂA knob	Tone	0 - 127	Adjust the frequency of the dedicated Band Pass Filter that is built in to the OSC bank.
ⓂB knob	Tone Type	GOLD, SILVER, BRONZE, TIN, COPPER, STEEL, IRON, NICKEL, ZINC, BRASS	<b>Change the tone type.</b> Switching between tone types will vary the pitch ratio of the OSC bank.
ⓂC knob	Tune	-1200 - 1200	Adjust the OSC tuning.
ⓂD knob	HP-F	0 - 127	Adjust the cutoff frequency of the dedicated High-Pass filter frequency applied to OSC1 and 2.

# Structure List

## CY RIDE

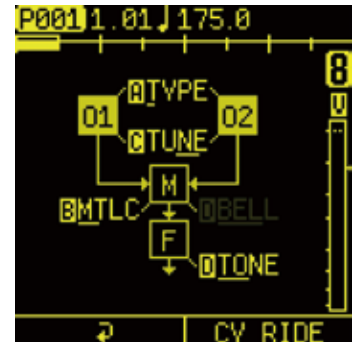
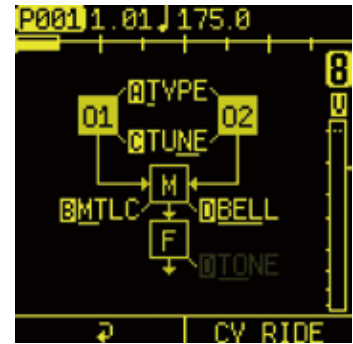
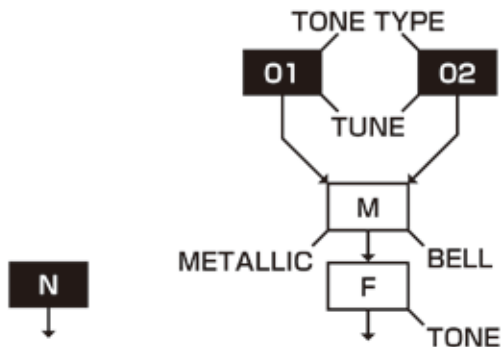

This is a Ride Cymbal structure that uses FM and ring modulation to recreate metallic sound textures.

Synthesis is performed by OSC1 and OSC2, which are frequency modulated and ring modulated in parallel, and then a high-pass filter is applied to the modulated signal.

BELL adjusts the signal's balance between FM and ring modulation. The adjustable METALLIC module adds metallic overtones to the sound.

Tone Type provides a choice between different metallic textures.

CY RIDE			
OSC1&2			
⊖A knob	Wave	1 - 64	Select a Wavetable.
⊖B knob	Release	0 - 127	Adjust the release time. It can also be edited on AMP page. (→ P.68)
⊖C knob	Direction	1 - 16	Select the way that the Wavetable will be scanned.
⊖D knob	Speed	0 - 127	Adjust the speed at which the Wavetable will be scanned.
⬇B (Push)	End	0 - 127	Adjust the end point of Wavetable scanning
⬇C (Push)	Start	0 - 127	Adjust the start point of Wavetable scanning
⬇D (Push)	Curve	-63 - 63	Adjust the curve of the speed of Wavetable scanning

# Structure List

---

## CY RIDE

Noise			
⊞A knob	Type	White, Pink, Brown, Purple, RESO	Select the Noise type.
⊞B knob	Frequency	0 - 127	Adjust the peak frequency of RESO Noise.
⊞C knob	Level	0 - 127	Adjust the level of Noise.
⊞D knob	Time	0 - 127	Adjust the length of time of the noise.
Tick			
⊞A knob	Pulse	Hi-F, Noise	Select the type of Pulse.
⊞B knob	Time	0 - 127	Adjust the length of time of the Pulse.
⊞C knob	Volume	0 - 127	Adjust the level of the Pulse.

# Structure List

## CY RIDE

SND			
Ⓐ knob	Tone Type	GOLD, SILVER, BRONZE, TIN, COPPER, STEEL, IRON, NICKEL, ZINC, BRASS	<b>Change the tone type.</b> Switching between tone types will vary the pitch ratio of the OSC bank.
Ⓑ knob	Metallic	0 - 127	<b>Adjust the amount of metallic overtones</b> The higher the value, the more overtones will be added to the sound.
Ⓒ knob	Tune	-1200 - 1200	Adjust the OSC tuning.
Ⓓ knob	BELL	0 - 127	<b>Adjust the balance between FM and ring modulation.</b> The higher the value, the louder the ring modulation signal. When set to 0, only the FM signal will be heard.
Ⓔ D (Push)	Tone	0 - 127	Adjust the cutoff frequency of the dedicated High-Pass Filter applied to the modulated signal.

# Hardware Specifications

Pads	15 velocity-sensitive pads with RGB LEDs
Controllers	Control knob x 5, Directional pad with 2 button controls
Display	1.5 inch OLED display
Built-in Mic	Mono x 1 (Omni-directional, 94dB SPL)
Built-in Speaker	Mono x 1 (1.5W 40hm)
Audio Inputs	INPUT L / Guitar (Switchable 10kOhm and 1MOhm impedance) [LINE Gain] PAD: -20dB [Hi-Z Gain] LOW: 0dB, NORMAL: +10dB, HI: +20dB INPUT R / Dynamic Microphone [LINE Gain] PAD: -20dB [MIC Gain] LOW: 0dB, NORMAL: +28.8dB, HI: +50dB
Audio Outputs	STEREO LINE OUTPUTS (Max +6.5dBV) <b>*The above jacks are all balanced 1/4 TRS Jack Connectors</b> PHONES jack (stereo 3.5mm mini jack type)
USB port	micro USB Type-B [USB Audio] USB 2.0 Full Speed, 48kHz-16bit Input: 2 channels, Output: 2 channels [USB MIDI] [Mass Storage Class] USB2.0 High Speed <b>*For some iOS devices, Apple Lightning to USB Camera Adapter is required separately</b>
MIDI ports	MIDI IN (5-Pin DIN type) MIDI OUT (5-Pin DIN type)
Other connectors	SYNC IN jack (mono 3.5mm mini jack type) SYNC OUT jack (mono 3.5mm mini jack type) External storage card slot (Standard size <b>*Supports external storage cards up to 32 GB</b> ) DC IN connector
Bottom side hole	1/4"20UNC screw for tripod mounting
Size and weight	mount Width: 147mm (approx. 5.8 inch) Depth: 175mm (approx. 7.8 inch) Height: 46mm (approx. 1.8 inch) Weight: 550g (approx. 1.2 lbs 3.5 oz)
Power supply	DC12V output AC adapter (500mA, Inner Diameter: 2.5mm, Outer Diameter: 5.5mm, Polarity: Center +) 6 AA batteries (rechargeable Ni-MH or alkaline) (Alkaline dry batteries life: approx. 4 hours) <b>*Batteries sold separately</b>
Accessories	32GB external storage card incl. 550 preset sound patches Power Supply Unit Warranty <b>*USB cable and the other connection cables sold separately</b>