

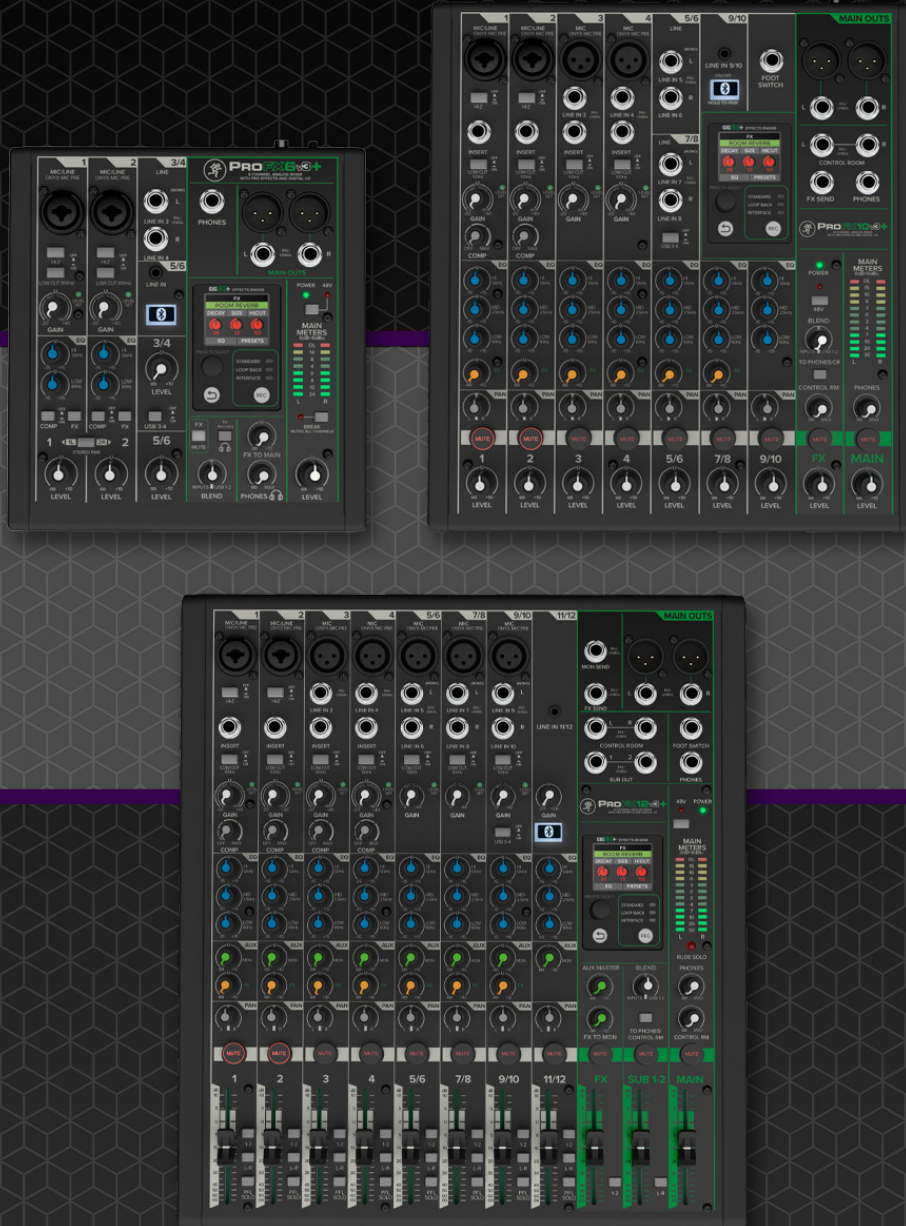

PROFXv3+ SERIES

MULTI-CHANNEL ANALOG MIXERS WITH ENHANCED FX,
USB RECORDING MODES, AND BLUETOOTH™

OWNER'S MANUAL



Important Safety Instructions

1. Read these instructions.
2. Keep these instructions.
3. Heed all warnings.
4. Follow all instructions.
5. Do not use this apparatus near water.
6. Clean only with a dry cloth.
7. Do not block any ventilation openings. Install in accordance with the manufacturer's instructions.
8. Minimum distance (5 cm) around the apparatus for sufficient ventilation. The ventilation should not be impeded by covering the ventilation openings with items, such as newspapers, table-cloths, curtains, etc.
9. Do not install near any heat sources such as radiators, heat registers, stoves, or other apparatus (including amplifiers) that produce heat.
10. No naked flame sources, such as lighted candles, should be placed on the apparatus.
11. Do not defeat the safety purpose of the polarized or grounding-type plug. A polarized plug has two blades with one wider than the other. A grounding-type plug has two blades and a third grounding prong. The wide blade or the third prong are provided for your safety. If the provided plug does not fit into your outlet, consult an electrician for replacement of the obsolete outlet.
12. Protect the power cord from being walked on or pinched particularly at plugs, convenience receptacles, and the point where they exit from the apparatus.
13. Only use attachments/accessories specified by the manufacturer.
14. Use only with a cart, stand, tripod, bracket, or table specified by the manufacturer, or sold with the apparatus. When a cart is used, use caution when moving the cart/apparatus combination to avoid injury from tip-over.
15. Unplug this apparatus during lightning storms or when unused for long periods of time.
16. Refer all servicing to qualified service personnel. Servicing is required when the apparatus has been damaged in any way, such as power-supply cord or plug is damaged, liquid has been spilled or objects have fallen into the apparatus, the apparatus has been exposed to rain or moisture, does not operate normally, or has been dropped.
17. This apparatus shall not be exposed to dripping or splashing, and no object filled with liquids, such as vases or beer glasses, shall be placed on the apparatus.
18. Do not overload wall outlets and extension cords as this can result in a risk of fire or electric shock.
19. This apparatus has been designed with Class-I construction and must be connected to a mains socket outlet with a protective earthing connection (the third grounding prong).



CAUTION

RISK OF ELECTRIC SHOCK! DO NOT OPEN!

CAUTION: TO REDUCE THE RISK OF ELECTRIC SHOCK DO NOT REMOVE COVER (OR BACK). NO USER-SERVICEABLE PARTS INSIDE. REFER SERVICING TO QUALIFIED PERSONNEL.

The lightning flash with arrowhead symbol within an equilateral triangle is intended to alert the user to the presence of uninsulated "dangerous voltage" within the product's enclosure, that may be of significant magnitude to constitute a risk of electric shock to persons.

The exclamation point within an equilateral triangle is intended to alert the user of the presence of important operating and maintaining (servicing) instructions in the literature accompanying the appliance.

Laitte on liitettävä suojakoskettimilla varustettuun pistorasiaan.

Apparatet stikprop skal tilsluttes en stikkontakt med jord, som giver forbindelse til stikproppens jord.

Apparatet må tilkoples jordnet stikkontakt.

Apparaten skall anslutas till jordat uttag.

20. This apparatus has been equipped with a rocker-style AC mains power switch. This switch is located on the rear panel and should remain readily accessible to the user.
 21. The MAINS plug or an appliance coupler is used as the disconnect device, so the disconnect device shall remain readily operable.
 22. The use of apparatus is in moderate climates.
 23. This device should be installed and operated with minimum distance 20cm between the radiator & your body.
- The product can be sold in all EU countries.
Bluetooth transmitter Power: ≤8dBm
Bluetooth transmitter frequency range: 2.402 – 2.480 GHz
- 24. NOTE:** This equipment has been tested and found to comply with the limits for a Class B digital device, pursuant to part 15 of the FCC Rules. These limits are designed to provide reasonable protection against harmful interference in a residential installation. This equipment generates, uses, and can radiate radio frequency energy and, if not installed and used in accordance with the instructions, may cause harmful interference to radio communications.

However, there is no guarantee that interference will not occur in a particular installation. If this equipment does cause harmful interference to radio or television reception, which can be determined by turning the equipment off and on, the user is encouraged to try to correct the interference by one or more of the following measures:

- Reorient or relocate the receiving antenna.
- Increase the separation between the equipment and the receiver.
- Connect the equipment into an outlet on a circuit different from that to which the receiver is connected.
- Consult the dealer or an experienced radio/TV technician for help.

CAUTION: Changes or modifications to this device not expressly approved by LOUD Audio, LLC. could void the user's authority to operate the equipment under FCC rules.

This device complies with Part 15 of the FCC rules and Industry Canada's license-exempt RSS standard(s). Operation is subjected to the following two conditions:
(1) This device may not cause harmful interference, and
(2) This device must accept any interference received, including interference that may cause undesired operation.

25. This apparatus does not exceed the Class B limits for radio noise emissions from digital apparatus as set out in the radio interference regulations of the Canadian Department of Communications.
CAN ICES-003(B)/NMB-003(B)
ATTENTION — *Le présent appareil numérique n'émet pas de bruits radioélectriques dépassant les limites applicables aux appareils numériques de class A/de class B (selon le cas) prescrites dans le règlement sur le brouillage radioélectrique édicté par les ministere des communications du Canada.*
26. Exposure to extremely high noise levels may cause permanent hearing loss. Individuals vary considerably in susceptibility to noise-induced hearing loss, but nearly everyone will lose some hearing if exposed to sufficiently intense noise for a period of time. The U.S. Government's Occupational Safety and Health Administration (OSHA) has specified the permissible noise level exposures shown in the following chart.

According to OSHA, any exposure in excess of these permissible limits could result in some hearing loss. To ensure against potentially dangerous exposure to high sound pressure levels, it is recommended that all persons exposed to equipment capable of producing high sound pressure levels use hearing protectors while the equipment is in operation. Ear plugs or protectors in the ear canals or over the ears must be worn when operating the equipment in order to prevent permanent hearing loss if exposure is in excess of the limits set forth here:

Duration, per day in hours	Sound Level dBA, Slow Response	Typical Example
8	90	Duo in small club
6	92	
4	95	Subway Train
3	97	
2	100	Very loud classical music
1.5	102	
1	105	Chaz screaming at Troy about deadlines
0.5	110	
0.25 or less	115	Loudest parts at a rock concert

WARNING — To reduce the risk of fire or electric shock, do not expose this apparatus to rain or moisture.



Correct disposal of this product: This symbol indicates that this product should not be disposed of with your household waste, according to the WEEE directive (2012/19/EU) and your national law. This product should be handed over to an authorized collection site for recycling waste electrical and electronic equipment (EEE). Improper handling of this type of waste could have a possible negative impact on the environment and human health due to potentially hazardous substances that are generally associated with EEE. At the same time, your cooperation in the correct disposal of this product will contribute to the effective usage of natural resources. For more information about where you can drop off your waste equipment for recycling, please contact your local city office, waste authority, or your household waste disposal service.

Table of Contents

Important Safety Instructions	2
<hr/>	
Table of Contents	3
<hr/>	
Chapter 1 : Welcome	6
<hr/>	
Introduction	6
Features	6
Things to Remember	7
About This Guide	7
Getting Started	8
<hr/>	
Chapter 2 : ProFXv3+ Rear Panel Features	9
<hr/>	
Introduction	9
Power Connector [ProFX6v3+ and ProFX10v3+]	9
Power Connector [ProFX12v3+]	10
Power Switch	10
USB-C Computer Jack	10
<hr/>	
Chapter 3 : ProFXv3+ Top Panel Features	11
<hr/>	
Introduction	11
XLR and 1/4" Combo Input Jacks	11
XLR Mic Input Jacks [ProFX10v3+ and ProFX12v3+]	12
1/4" Line Input Jacks [ProFX10v3+ and ProFX12v3+]	12
1/4" Stereo Line Input Jacks	13
1/8" Stereo Line Input Jack	14
Line / Hi-Z Switches [Chs. 1 and 2]	15
Low Cut Switches	15
1/4" Insert Jacks [ProFX10v3+ and ProFX12v3+]	16
Gain Knobs and Level Set LEDs	17
Compressor Knobs	18
Channel Equalization (EQ)	19
Aux Mon Knobs [ProFX12v3+]	20
FX Knobs	21
Pan Knobs	21

Mute Switches [ProFX10v3+ and ProFX12v3+]	22
Channel Level Knobs and Faders	22
Assign Switches [ProFX12v3+]	23
PFL Solo Switches [ProFX12v3+]	23
USB 3-4 Switch	24
Bluetooth Switch	24
FX Footswitch Jack [ProFX10v3+ and ProFX12v3+]	24
L/R Main Output Jacks	25
1/4" Headphone Output Jack	26
1/4" Control Room Jacks [ProFX10v3+ and ProFX12v3+]	26
1/4" FX Send Jack [ProFX10v3+ and ProFX12v3+]	27
1/4" Mon Send Jack [ProFX12v3+]	27
1/4" Sub Out Jacks [ProFX12v3+]	27
48V Phantom Power Switch	28
Power LED	28
Main Meters	28
Rude Solo [ProFX12v3+]	29
Aux Master Knobs [ProFX10v3+ and ProFX12v3+]	29
FX to Mon Knob [ProFX12v3+]	30
FX Mute Switch	30
To Phones / Control Room Switch	30
Control Room Knob [ProFX10v3+ and ProFX12v3+]	30
Phones Knob	31
Blend Knob	31
FX Knob / Fader	31
FX to Sub Switch [ProFX12v3+]	31
Sub 1-2 Faders [ProFX12v3+]	32
Sub 1-2 Assign Switch [ProFX12v3+]	32
Sub 1-2 Mute Switch [ProFX12v3+]	32
Main Mix Knob / Fader	33
Main Mute / Break Switch	33
GIGFX+ Effects Engine	34
Preset Display	34
Back Button	34
Factory Reset	34
FX Section	35
Delay	36
FX EQ	37
Delay Parameters and Values	38
Echo Parameters and Values	39
Slapback Parameters and Values	39
FX Presets	40
FX EQ Reset	41
Hall Reverb Parameters and Values	42
Room Reverb Parameters and Values	42
Plate Reverb Parameters and Values	42
Chorus 1 Parameters and Values	43
Chorus 2 Parameters and Values	43
Flanger Parameters and Values	44
Delay + Reverb Parameters and Values	45
Delay + Chorus Parameters and Values	45
Reverb + Chorus Parameters and Values	46
Watering Parameters and Values	47
Recording Mode	47

Hookup Diagrams 48

Hookup Diagrams > Typical Live Sound System 48
Hookup Diagrams > Typical Recording System..... 49

Appendix A : Service Information..... 50

Troubleshooting..... 50
 No Power..... 50
 No Sound..... 50
 Noise / Hum..... 51
 Other Issues..... 51
 Videos..... 51
Microphone Stand..... 52
Repair 52

Appendix B : Technical Information 53

Specifications 53
Dimensions 57
Track Sheets..... 58

Appendix C : USB 3/4 Return Setup..... 61

Introduction..... 61
Windows 61
Mac 61

Warranty Statement 62

Fin 63

Chapter 1 : Welcome

Introduction

Hello everyone! This is the ProFXv3+ Series Owner's Manual. This document contains detailed information about the ProFXv3+ Series... we hope you like it!

Stream. Record. Create.

Mackie ProFXv3+ is a professional analog mixer and USB-C audio interface with powerful enhancements for studio-quality recordings and live streams.

Capture your performance with award-winning Onyx preamps, channel EQ and analog compression.

Upgraded GigFX+ effects enhance your sound, plus you can edit and save your presets on the fly via the full-color display.

Switch between recording modes to track dry or include the FX, or use loopback mode to stream video games or perform over backing tracks without feedback.

You can even bring in podcast guests over the phone via Bluetooth® on a dedicated channel.

With easy connectivity, the warmth of analog and an upgraded FX engine, Mackie ProFXv3+ is the perfect centerpiece for your studio.

So there you have it. Again, we hope you like it. If you have any questions or comments about this Owner's Manual (or other Mackie documentation), please don't hesitate to contact us:

- 1-800-898-3211 (Monday through Friday, normal business hours, Pacific Time)
- www.mackie.com/support-contact

Features

- 2 Onyx mic pres with up to 60 dB of gain and ultra-low noise performance [ProFX6v3+]
- 4 Onyx mic pres with up to 60 dB of gain and ultra-low noise performance [ProFX10v3+]
- 7 Onyx mic pres with up to 60 dB of gain and ultra-low noise performance [ProFX12v3+]
- High-resolution GigFX+™ effects engine
- Full-color LCD display for editing and saving effects presets
- 24-Bit / 192 kHz 2x4 USB-C audio interface
- Three recording modes: Standard, Loopback and Interface
- Bi-directional Bluetooth® for music playback and caller integration
- 2-band EQ on channels 1 and 2 [ProFX6v3+]
- 3-band EQ on all channels [ProFX10v3+ and ProFX12v3+]
- One-button compression on channels 1 and 2 [ProFX6v3+]
- One-knob compression on channels 1 and 2 [ProFX10v3+]
- One-knob compression on channels 1-4 [ProFX12v3+]
- Hi-Z switches allow direct connection of instruments
- 100 Hz low-cut filter and 48V phantom power on all mic channels
- Stereo 1/8" input
- Separate FX, monitor and subgroup busses [ProFX12v3+]

- Headphone output with separate level and blend control
- Easily blend between monitoring your computer output and a latency-free feed from the mixer
- Waveform OEM™ recording software Included
- Legendary Built-Like-A-Tank design
- Solid steel chassis
- Tough ABS side protection

Things to Remember

- Never listen to loud music for prolonged periods.
Please see the Safety Instructions on page 2 for information on hearing protection.
- As a general guide, the ProFXv3+ should be turned on first, subwoofers next, and the loudspeakers last. As such, the loudspeakers should also be turned off first, followed by the subwoofers, then the ProFXv3+. This will reduce the possibility of any turn-on or turn-off thumps and other noises generated by any upstream equipment from coming out of the speakers.
- Save the shipping boxes and packing materials! You may need them someday. Besides, the cats will love playing in them and jumping out at you unexpectedly. Remember to pretend like you are surprised!
- Save your sales receipt in a safe place.

About This Guide

This guide is designed to be accessible, with subsections as complete as practical to minimize having to electronically leaf back and forth looking for the whole story. The entire guide does not need to be read to figure out how to use this console.

As the saying goes, “a picture tells a 1000 words”. With that thought in mind, we added quite a few illustrations, screenshots and other images throughout to accompany the text.



This icon marks information that is critically important or unique! For your own good, read and remember them.



There's an illustration of a microscope, so, of course, you're going to get more detailed information when you see this little guy. There are explanations of features and practical tips listed here.



It's a good idea to pay attention to text displayed next to a note icon, as this icon draws attention to certain features and functions relating to the usage of ProFXv3+.

Getting Started

The following steps will help you set up the ProFXv3+ quickly. If you desire a more thorough walk-through of ProFXv3+, there is a wealth of information in the following pages!

1. Read and understand the Important Safety Instructions on page 2.
2. Turn down all knobs except the channel EQ and pan knobs, and set all the faders fully down.
3. Set all channel EQ knobs and pan knobs at their center detent.
4. Disengage all switches.
5. Connect cords from the main outs to powered speakers (or to an amplifier connected to passive speakers).
6. Push the line cord securely into the mixer's connector and plug the other end into a grounded AC outlet. The mixer may accept the appropriate voltage as indicated near the connector.
7. Turn the mixer on.
8. Turn the powered speakers (or amplifiers) on.
9. Plug signal sources into the mixer, such as:
 - Microphones plugged into the mic inputs. (Engage phantom power if needed.)
 - Instrument level sources, such as acoustic guitars w/active pickups into the instrument inputs
 - Line-level sources such as keyboards, drum machines, or CD players plugged into the line-level inputs.
 - Smartphone paired and connected via Bluetooth.
10. Be sure that the volume of the input is the same as it would be during normal use.
11. Engage the channel's L-R assign switch (ProFX12v3+) and turn up that channel's fader to the "U" (unity gain) position.
12. Slowly bring up the main fader to a comfortable listening level.
13. Repeat steps 9 to 11 for the other channels.

Chapter 2 : ProFXv3+ Rear Panel Features



ProFX6v3+ and ProFX10v3+



ProFX12v3+

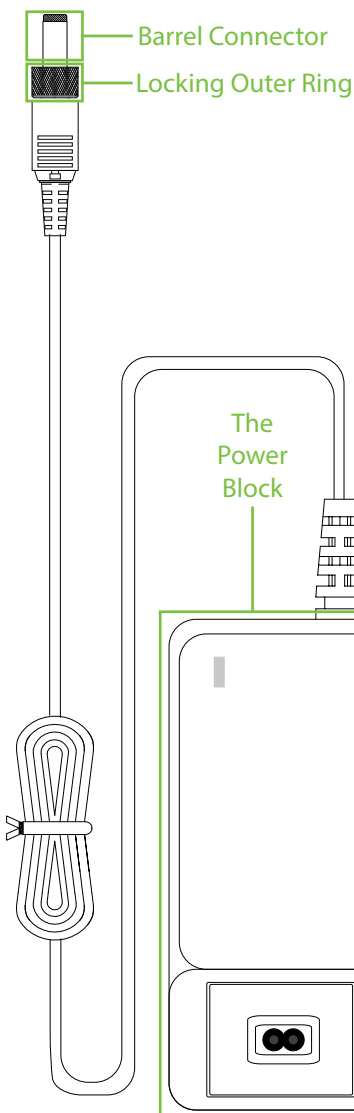

Introduction

The top panel of each ProFXv3+ mixer may be where the magic all happens, but nothing will happen if it can't be powered up, so let's start there! The rear panel of each ProFXv3+ mixer is outfitted with a power connector, power switch, and a USB-C port for connecting to a computer. Let's take a look at each of these features, starting with the power connector and power switch, followed by a look at the USB-C port.

Power Connector [ProFX6v3+ and ProFX10v3+]

Each ProFX6v3+ and ProFX10v3+ has a universal external power supply that accepts any AC voltage ranging from 100 VAC to 240 VAC. No need for voltage select switches. It will work virtually anywhere in the world. That's why we call it a "Planet Earth" power supply! It is less susceptible to voltage sags or spikes compared to conventional power supplies, and provides greater electromagnetic isolation and better protection against AC line noise.

An external 12 VDC power supply [aka The Power Block] and a line cord are included with the ProFXv3+ mixer. A locking barrel connector resides at the end of the cord attached to The Power Block. Attach it to the power connector on the ProFXv3+ mixer and rotate the outer ring clockwise to lock. Do not over-tighten! Screw until there is resistance, then stop. Connect the female end of the line cord to The Power Block and plug the male end into a live grounded outlet. An LED on The Power Block will illuminate green to indicate success (whether the ProFXv3+ mixer is powered on or not).



Warning: Disconnecting the plug's ground pin is dangerous. Don't do it!

In fact, it's a bad idea to remove anything from (or add anything to) The Power Block or line cord. Again, don't do it!

Power Connector [ProFX12v3+]

This is a standard 3-prong IEC power connector. Connect the detachable power cord (included in the packaging with the ProFX12v3+) to the power receptacle, and plug the other end of the power cord into an AC outlet.



Make sure that the AC power is matched to the AC power indicated on the rear panel (near the IEC receptacle).

Warning: Disconnecting the plug's ground pin is dangerous. Don't do it!

Power Switch

Located next to the power connector is the power switch. Press the top of this rocker switch in to turn the ProFXv3+ mixer on and press the bottom of this switch in to turn it off.



As a general guide, the ProFXv3+ should be turned on first, followed by external power amplifiers or powered speakers. As such, the ProFXv3+ should also be turned off last. This will reduce the possibility of any turn-on or turn-off thumps in the PA.

USB-C Computer Jack

This is a 2x4 interface that allows audio to stream to and from the ProFXv3+ mixer via computer. Connect the USB-C side of a USB cable to the ProFXv3+ mixer and the USB-A side to the computer's USB port.



Don't forget to change the input and output to 'ProFXv3+' via Settings on your computer.



ProFXv3+'s USB connection is audio only. It is not a source of power.

Chapter 3 : ProFXv3+ Top Panel Features

Introduction

From top to bottom and left to right, the top panel of each ProFXv3+ mixer is outfitted with a bunch of knobs, buttons, faders, jacks, screens, and more. So much more, in fact, that we will call out and describe each one...

XLR and 1/4" Combo Input Jacks

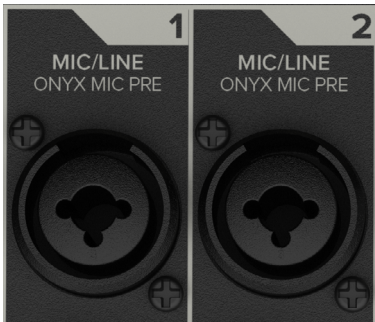

The first two input channels may accept a balanced mic or line-level signal using an XLR connector. They are wired as follows, according to standards specified by the AES (Audio Engineering Society).

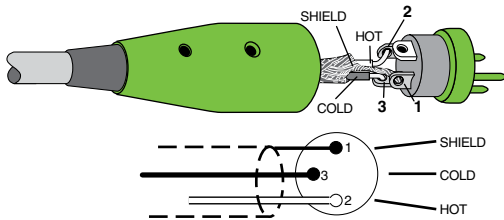

XLR Balanced Wiring:

- Pin 1 = Shield (ground)
- Pin 2 = Positive (+ or hot)
- Pin 3 = Negative (- or cold)

In addition to accepting balanced mic or line-level signals using an XLR connector, these inputs may also accept 1/4" line-level signals driven by balanced or unbalanced sources.

To connect balanced lines to these inputs, use a 1/4" Tip-Ring-Sleeve (TRS) plug. "TRS" stands for Tip-Ring-Sleeve, the three connection points available on a stereo 1/4" or balanced phone jack or plug. TRS jacks and plugs are used for balanced signals and stereo headphones and are wired as follows:

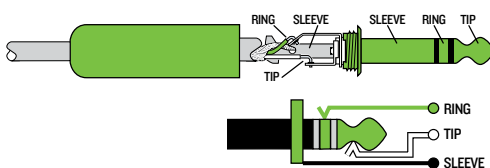

1/4" TRS Balanced Mono Wiring:

- Sleeve = Shield
- Tip = Hot (+)
- Ring = Cold (-)

To connect unbalanced lines to these inputs, use a 1/4" mono (TS) phone plug, wired as follows:

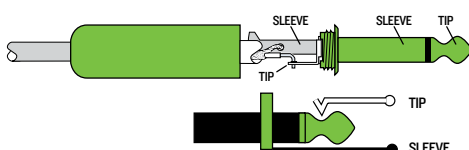

1/4" TS Unbalanced Mono Wiring:

- Sleeve = Shield
- Tip = Hot (+)

XLR Mic Input Jacks [ProFX10v3+ and ProFX12v3+]



ProFX10v3+



ProFX12v3+

This is a female XLR connector that accepts a balanced mic or line level input from almost any type of source. These mic preamps feature higher fidelity and headroom rivaling any standalone mic preamp on the market today. These circuits are excellent at rejecting hum and noise.

Professional ribbon, dynamic, and condenser mics all sound excellent through these inputs. The mic / line inputs will handle any kind of level you can toss at them, without overloading. The wiring diagrams are presented on the previous page.



VERY IMPORTANT NEVER connect the output of an amplifier directly to a ProFXv3+ mixer's input jack. This could damage the input circuitry and we wouldn't want that now, would we?



NOTE As seen in the pictures above, the ProFX10v3+ has two XLR mic input jacks (on channels 3 and 4), while the ProFX12v3+ boasts a mighty five XLR mic input jacks (on channels 3 and 4, 5/6, 7/8 and 9/10). There are no XLR mic input jacks on the ProFX6v3+ (other than the first two channel combo input jacks).

1/4" Line Input Jacks [ProFX10v3+ and ProFX12v3+]



ProFX10v3+



ProFX12v3+

These 1/4" jacks share circuitry (but not phantom power) with the mic preamps, and can be driven by balanced or unbalanced sources at almost any level. You can use these inputs for virtually any signal you'll come across.

To connect balanced lines to these outputs, use a 1/4" Tip-Ring-Sleeve (TRS) plug. "TRS" stands for Tip-Ring-Sleeve, the three connection points available on a stereo 1/4" or balanced phone jack or plug. The wiring diagrams are presented on the previous page.



VERY IMPORTANT NEVER connect the output of an amplifier directly to a ProFXv3+ mixer's input jack. This could damage the input circuitry and we wouldn't want that now, would we?



NOTE As seen in the pictures above, both the ProFX10v3+ and ProFX12v3+ have two 1/4" line input jacks (on channels 3 and 4). There are no 1/4" input jacks on the ProFX6v3+ (other than the first two channel combo input jacks).

1/4" Stereo Line Input Jacks



The stereo line inputs are designed for 1/4" TRS balanced or 1/4" TS unbalanced signals. They may accept any line-level instrument, effects device, CD player, etc.

If you are connecting a mono source, use the left (mono) input, and the mono signals will appear on both sides of the main mix.

To connect balanced lines to these inputs, use a 1/4" Tip-Ring-Sleeve (TRS) plug. To connect unbalanced lines to these inputs, use a 1/4" mono (TS) phone plug. The wiring diagrams were presented two pages ago.



VERY IMPORTANT NEVER connect the output of an amplifier directly to a ProFXv3+ mixer's input jack. This could damage the input circuitry and we wouldn't want that now, would we?



NOTE As seen in the pictures above, the ProFX6v3+ has one pair of 1/4" stereo line input jacks (on channels 3/4), the ProFX10v3+ has two pairs of 1/4" stereo line input jacks (on channels 5/6 and 7/8), and the ProFX12v3+ has three pairs of 1/4" stereo line input jacks (on channels 5/6, 7/8 and 9/10).

1/8" Stereo Line Input Jack

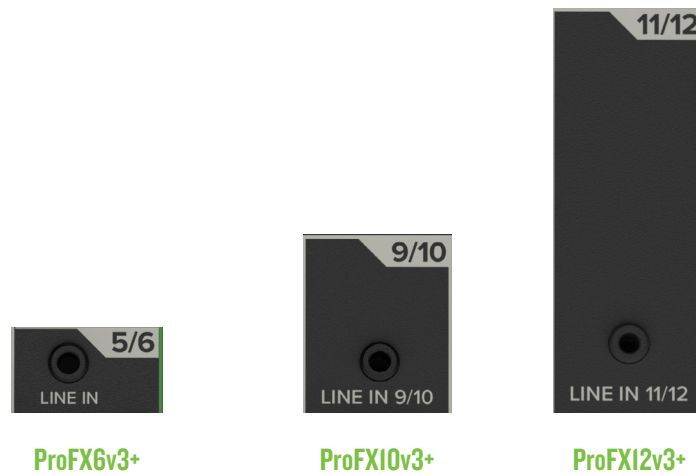

This 1/8" stereo input may accept a stereo or mono line-level signal from a smartphone, tablet, MP3 player, CD player or other signal source.

It is wired as follows, according to standards specified by the AES (Audio Engineering Society):

Stereo 1/8" TRS

Sleeve = Shield (Ground)
Tip = Left Channel
Ring = Right Channel

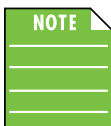

While the volume may be raised and lowered via the ProFXv3+ mixer, the volume of the device also needs to be up.

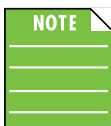

As seen in the pictures above, all ProFXv3+ mixers come with a single 1/8" stereo line input jack. It is stereo channels 5/6 on the ProFX6v3+, 9/10 on the ProFX10v3+ and 11/12 on the ProFX12v3+.

Line / Hi-Z Switches [Chs. 1 and 2]

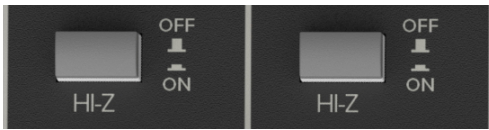

To connect a guitar or bass directly to the mixer without using a DI Box, press this switch in first; then connect the output from the instrument to the channel's 1/4" TRS input. The input impedance is optimized for direct connection and high-frequency fidelity is assured.

In the out position, the channel's 1/4" TRS input becomes a line input just like the other mono line inputs.

To use guitars or other instruments on other channels, you will need to use an external DI box first. Without the DI box – or if this switch is not pressed in – guitars may sound dull and muddy.

Low Cut Switches

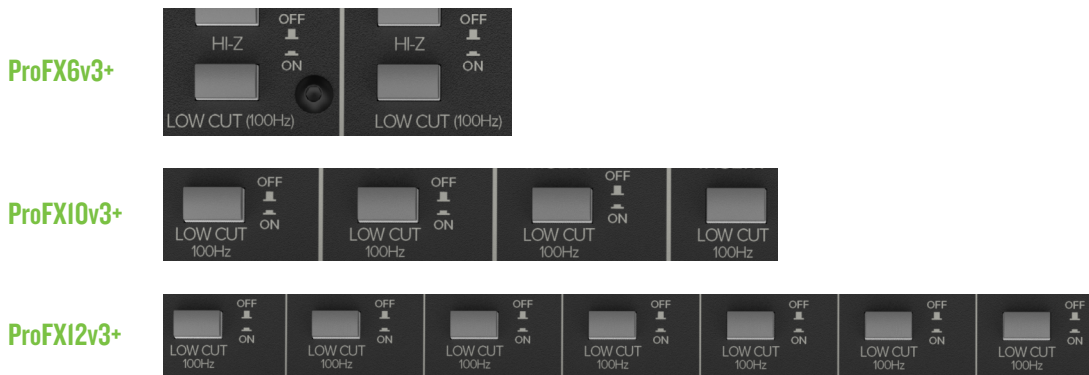

All channels with a mic input have a low-cut switch (often referred to as a high-pass filter) that cuts bass frequencies below 100 Hz at a rate of 18 dB per octave.

We recommend that you use low-cut on every microphone application except kick drum, bass guitar, or bassy synth patches. These aside, there isn't much down there that you want to hear, and filtering it out makes the low stuff you do want much more crisp and tasty. Not only that, but low-cut can help reduce the possibility of feedback in live situations, and it helps to conserve amplifier power.



Another way to consider low-cut's function is that it actually adds flexibility during live performances. With the addition of low-cut, you can safely use low equalization on vocals. Many times, bass shelving EQ can really benefit voices. Trouble is, adding low EQ also boosts stage rumble, mic handling clunks and breath pops from way-down low. Applying low-cut removes all those problems, so you can add low EQ without blowing the woofers.



As seen in the pictures above, the ProFX6v3+ has two low cut switches, the ProFX10v3+ doubles that number with four low cut switches, and the ProFX12v3+ has a whopping seven low cut switches.

1/4" Insert Jacks [ProFX10v3+ and ProFX12v3+]

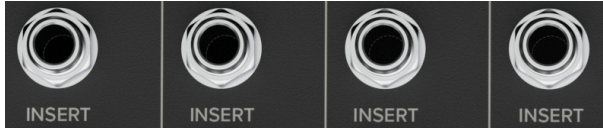

These unbalanced 1/4" jacks are for connecting serial effects processors such as compressors, equalizers, de-essers, or filters.

The insert point is after the gain control and low cut filter, but before the channel's EQ and level. The channel signal can go out of the insert jack to an external device, be processed and come back in on the same insert jack.

To do this requires a standard insert cable that must be wired thusly:

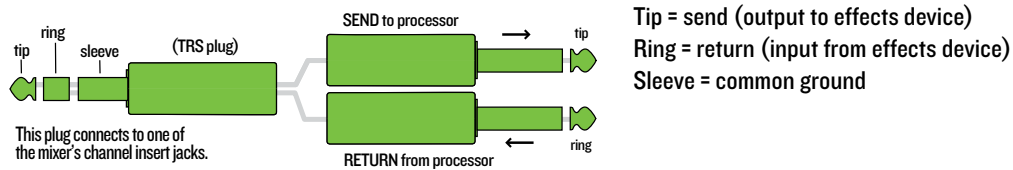

Insert jacks may be used as channel direct outputs; post-gain, and pre-EQ. If you insert a TS (mono) 1/4" plug only partially (to the first click) into an insert jack, the plug will not activate the jack switch and will not open the insert loop in the circuit (thereby allowing the channel signal to continue on its merry way through the mixer). This allows you to tap out the channel signal without interrupting normal operation.

If you push the 1/4" TS plug in to the second click, you will open the jack switch and create a direct out, which does interrupt the signal in that channel. See illustration below.



Do not overload or short-circuit the signal you are tapping from the mixer. That will affect the internal signal.

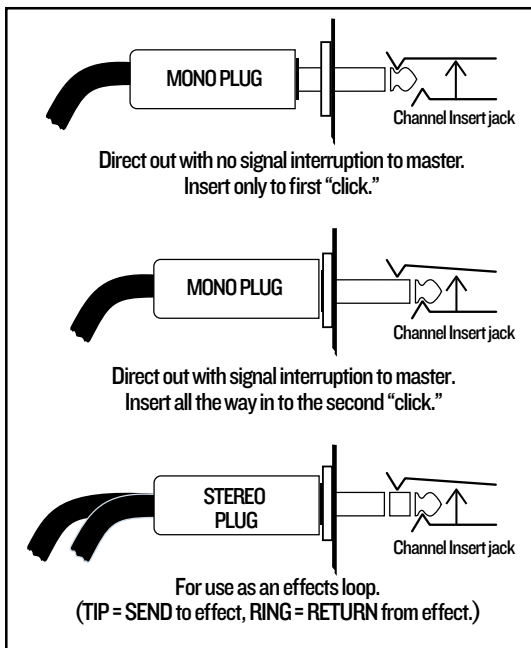

As seen in the pictures above, both the ProFX10v3+ and ProFX12v3+ have four 1/4" insert jacks (on channels 1-4). There are no 1/4" insert jacks on the ProFX6v3+.

Gain Knobs and Level Set LEDs

“U” like Unity Gain

ProFXv3+ Series mixers have a “U” symbol on many level controls. It stands for “unity gain,” meaning no change in signal level. The labels on the controls are measured in decibels (dB), so you’ll know what you’re doing level-wise if you choose to change a control’s settings.

ProFX6v3+



ProFX10v3+



ProFX12v3+



If you haven’t already, please read the “Getting Started” section on page 8. Setting the gain correctly will ensure that the preamplifier’s gain is not too high, where distortion could occur, and not too low, where the quieter, exquisitely-delicate passages might be lost in background noise.

The gain knobs – in conjunction with the level set LEDs – adjust the input sensitivity of the mic and line inputs. This allows signals from the outside world to be adjusted to run through each channel at optimal internal operating levels.

For mono channels (mic input with a mono line input), the gain knob adjusts the input sensitivity of the mic and line inputs.

If the signal originates through the mic XLR jack, there will be 0 dB of gain with the knob fully down, ramping to 60 dB of gain fully up.

Through the 1/4” mono line inputs, there is -20 dB of attenuation fully down and 40 dB of gain fully up, with unity gain “U” at 12:00.

This 20 dB of attenuation can be very handy when you are inserting a hot signal, or when you want to add EQ gain, or both. Without this “virtual pad,” there is more chance of channel clipping.

For hybrid channels (mic input and stereo line input), the gain control just affects the microphone input.

Hybrid Channels:

- ProFX12v3+ – Channels 5/6, 7/8, 9/10

Only the ProFX12v3+ has hybrid channels.

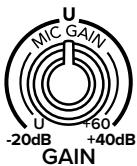

The gain control on the 1/8” stereo input channel has 20 dB of gain and 20 dB of attenuation.

1/8” Stereo Channels:

- ProFX12v3+ – Channels 11/12



While all ProFXv3+ mixers are blessed with an 1/8” stereo line input jack, only the ProFX12v3+ has a gain knob associated with it.

Next to every gain knob – except the 1/8" stereo input gain knob – lies a level set LED. These LEDs are used with the gain control to set the channel preamplifier gain just right for each source. If one or more channels are distorting, check the level set LEDs. If they are on continuously, turn down the gain.

Compressor Knobs

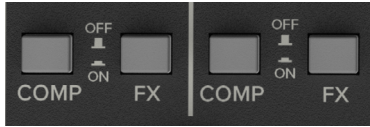

ProFX6v3+



ProFX10v3+



ProFX12v3+

The following channels of each ProFXv3+ mixer has an in-line compressor circuit with a variable threshold.

- ProFX6v3+ – On/Off compressor switches
- ProFX10v3+ – Channels 1-2
- ProFX12v3+ – Channels 1-4

This is very useful for compression of vocals, and snare drums, for example, so you might consider connecting your vocal and drum mics to these channels, rather than one of the other channels.

When the incoming signal exceeds the threshold level set by this knob, the signal level is automatically compressed. This reduces the dynamic range and reduces the chance of distortion due to overloading the input signals.



Dynamic range is the difference in level between the quietest and loudest parts of a song. A compressor “squeezes” the dynamic range, resulting in an overall steadier, more constant volume level for the signal. It helps sources, such as vocals, “sit” properly in the mix; it is very useful for live sound.

The compression ratio is fixed at around 6:1, with a soft knee response. The threshold can be adjusted clockwise from off (no compression) to 0 dBu (max).

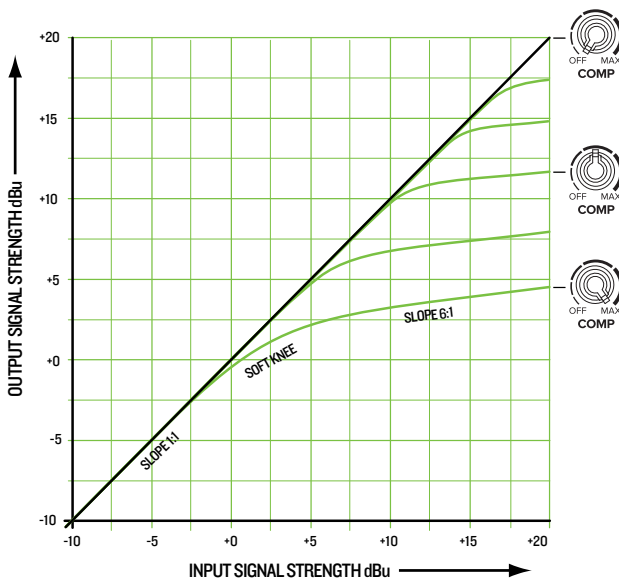

As an example, suppose the threshold is set to maximum. An incoming signal reaches the threshold of 0 dBu. As it increases beyond the threshold, it becomes compressed at a ratio of 6:1. This means that even if the input further increases by 6 dB, the actual output only increases by 1 dB. This compresses the output signal, so there is more protection to your system from distortion and overload due to poor microphone technique (say it ain't so) and general pops, bangs and heavy metal screaming. The soft knee means that the compression slowly ramps up to 6:1 from the threshold. It does not jump abruptly to 6:1, as this would be hard knee compression, and harder on the ears too.

The graph to the left displays the input signal level going into the compressor, versus the output level coming out of it. It is the typical graph to view when compressors are discussed, and is just the kind of thing our engineers like to discuss during the company Christmas party¹.

If the compressor is off, then the input = output. For example, an input signal level of +5 dBu results in an output level of +5 dBu. The diagonal line from lower left to upper right represents $x = y$, that is, input = output.

At the maximum compression, the threshold is set at 0 dBu, and the input to output relationship is represented by the lower curve. If the input is -5 dBu (that is, below the threshold), the output is -5 dBu. As the input reaches 0 dBu, the output is a bit less than 0 dBu. If the input is +5 dBu, the output is about +2 dBu. If the input reaches +10 dBu, then the output is +3 dBu. Notice the shapely curve of the soft knee between the diagonal slope of $x = y$ and the compressor slope of 6:1 (the compression ratio).

¹ My High School math teacher, Mr. Marvin, thought that graphs might come in handy for me one day. Finally!

The other green curves represent in-between positions of the compressor knob, with higher thresholds before compression begins.

Outboard compressors often have controls such as compression ratio, threshold, soft knee/hard knee, attack time, and release time. These last two affect how quickly the compressor kicks in when the input exceeds the threshold, and how quickly it is released after it drops below the threshold. In this compressor, these parameters are specially chosen to give you the best overall performance.

Adjust the threshold carefully, so your dynamic range is still lovely, without distortion or overload during the performance. Run through a few practice screams and high-notes, and adjust the compression as required.



While the compressor on the ProFX10v3+ and ProFX12v3+ both have a variable threshold, the ProFX6v3+ has an easy on/off switch.

Channel Equalization (EQ)



ProFX6v3+



ProFX10v3+ & ProFX12v3+

ProFX10v3+ and ProFX12v3+ mixers have 3-band EQ with shelving hi, peaking mid, and shelving low, while the ProFX6v3+ has shelving hi and low EQ knobs. The 3-band equalization has low shelving at 80 Hz, mid peaking at 2.5 kHz, and high shelving at 12 kHz.

Shelving means that the circuitry boosts or cuts all frequencies past the specified frequency. For example, the low EQ boosts bass frequencies below 80 Hz and continuing down to the lowest note you never heard. Peaking means that certain frequencies form a “hill” around the center frequency.



With too much EQ, you can really upset things. We’ve designed a lot of boost and cut into each equalizer circuit because we know that everyone will occasionally need that. But if you max the EQ on every channel, you’ll get mix mush. Equalize subtly and use the left sides of the knobs (cut), as well as the right (boost). If you find yourself repeatedly using a lot of boost or cut, consider altering the sound source, such as placing a mic differently, trying a different kind of mic, a different vocalist, changing the strings, or gargling.

The EQ circuits are based upon the designs of Cal Perkins, an industry-leader in audio engineering for over four decades and a long-time collaborator. This “neo-classic” design provides the sweet musicality of the British EQ sound, while still maintaining 15 dB of boost and cut with optimum Q and minimum phase shift (in other words, it gives you plenty of control and is pleasing to the ear!).

Hi EQ Knobs

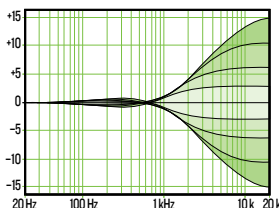

The hi EQ provides up to 15 dB of boost or cut above 12 kHz, and it is also flat (no boost or cut) at the detent. Use it to add sizzle to cymbals, an overall sense of transparency, or an edge to keyboards, vocals, guitar and bacon frying. Turn it down a little to reduce sibilance or to mask tape hiss.

Mid EQ Knobs

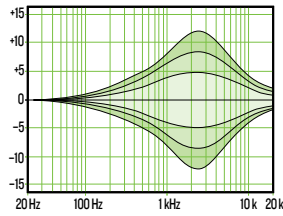

Short for “midrange,” this knob provides up to 15 dB of boost or cut, centered at 2.5 kHz, also flat at the center detent. Midrange EQ is often thought of as the most dynamic, because the frequencies that define any particular sound are almost always found in this range. You can create many interesting and useful EQ changes by turning this knob down as well as up.

Low EQ Knobs

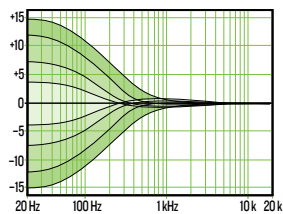

The low EQ provides up to 15 dB of boost or cut below 80 Hz. The circuit is flat at the center detent position. This frequency represents the punch in bass drums, bass guitar, fat synth patches, and some really serious male singers who eat raw beef for breakfast.

Aux Mon Knobs [ProFX12v3+]



These knobs tap a portion of each channel's signal to set up a nice monitor mix feeding stage monitors, independent of the main mix. Adjust these controls on each channel until the band is happy with the stage monitor mix.

The controls are off when fully turned down, deliver unity gain at the center detent, and can provide up to 10 dB of gain turned fully up.

The pan and channel fader do not affect the monitor output, but the other channel controls will. The aux mon is pre-fader.

The overall output level may be adjusted with the master mon control. Both the channel aux mon knobs and master aux mon knob are colored green. Internal FX may also be added to the monitor mix with the FX to mon master knob.

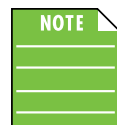

As seen in the picture above, the ProFX12v3+ has eight aux mon knobs. There are no aux mon knobs on the ProFX6v3+ and ProFX10v3+.

FX Knobs

ProFX6v3+

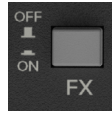

ProFX10v3+ & ProFX12v3+



FX Switches (Chs. 1–2) [ProFX6v3+]:

With this switch out, no FX are added to the mix. With this switch in, the channel is assigned to the FX send post-channel level knob.

FX Knobs [ProFX10v3+ and ProFX12v3+]:

These knobs tap a portion of each channel's signal to set up a nice FX mix feeding the internal FX processor, and to feed external processors via the FX send.

The controls are off when fully turned down, deliver unity gain at the center detent, and can provide up to 10 dB of gain turned fully up.

The mute, channel fader and other channel controls affect the FX output, but pan does not. The FX is post-fader.

The FX signal reaching the internal FX processor and the FX send output jack is the sum (mix) of all the channels whose FX control is set to more than minimum.

The overall output level may be adjusted with the master FX fader

Pan Knobs

ProFX6v3+



ProFX10v3+ & ProFX12v3+



Stereo Pan Switch (Chs. 1–2) [ProFX6v3+]: With this switch out, each mono channel feeds both the left and right sides of the main mix equally. For example:

- Playing a mono source: If you talk into a microphone connected to input 1, your sweet tones will be heard in both the left and right loudspeakers.
- Overdubbing a mono source: if you are monitoring directly through the headphones, you can hear the overdub signal in both ears while you are playing.

With this switch pressed in, channel 1 will play only in the left side of the main mix, and channel 2 will play in the right side. For example:

- Recording a stereo source: If you have a stereo microphone connected to the mic inputs, or if you are playing a stereo source into the line inputs, each side of the source can be recorded discretely onto a recorder connected to the main outputs.

The pan switch does not affect the other channels.

Pan Knobs [ProFX10v3+ and ProFX12v3+]: This control allows you to adjust how much of the channel signal is sent to the left versus the right outputs.

The pan control employs a design called “Constant Loudness.” If you have a channel panned hard left (or right) and then pan to the center, the signal is attenuated about 3 dB to maintain the same apparent loudness. Otherwise, it would make the sound appear much louder when panned center.

Mute Switches [ProFX10v3+ and ProFX12v3+]



Mute switches do just what they sound like they do. They turn off the signal by “routing” it into oblivion. Engaging a channel’s mute switch (almost) provides the same results as turning the fader all the way down (a pre-aux send is not affected by the channel fader, but it is by the mute switch).

The channel insert will continue to provide a signal when a channel is muted. Mute switches illuminate red when engaged.



The ProFX10v3+ has seven mute switches, while the ProFX12v3+ has eight. There are no mute switches on the ProFX6v3+.

Channel Level Knobs and Faders

ProFX6v3+



ProFX10v3+

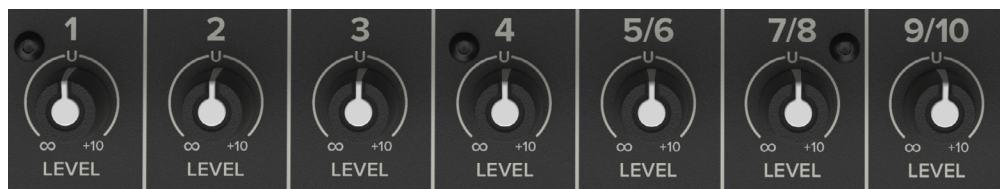

ProFXI2v3+

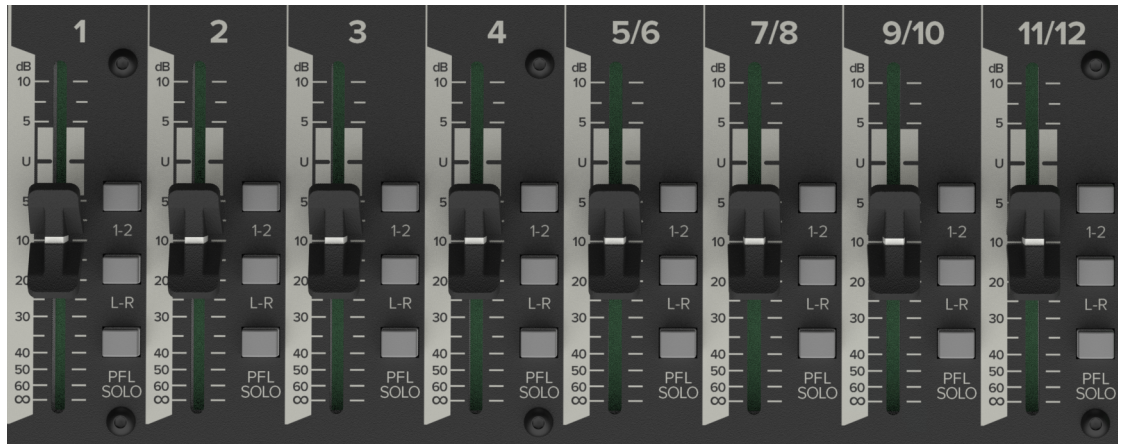

This is the last control in a channel's signal path, and it adjusts the level of each channel onto the main mix. The "U" mark indicates unity gain, meaning no increase or decrease of signal level. All the way up provides an additional 10 dB, should you need to boost a section of a song. If you find that the overall level is too quiet or too loud with the level near unity, check that the gain control is set correctly.



The "Channel Faders" on the ProFX6v3+ and ProFXI0v3+ are actually "Channel Knobs". But they behave similarly.

Assign Switches [ProFXI2v3+]

Alongside each channel fader are channel assignment switches. They are used for routing the channel's signal to subgroup 1-2 and/or the main L-R outputs.

If you are doing a mixdown to a 2-track, for example, simply engage the main mix switch on each channel that you want to hear, and they will be sent to the main mix bus.



As seen in the picture above, the ProFXI2v3+ has assign switches to the right of the channel faders on chs. 1-11/12. There are no assign switches on the ProFX6v3+ and ProFXI0v3+.

PFL Solo Switches [ProFXI2v3+]

When a channel's solo switch is engaged, any existing selection is replaced by the solo signal, appearing at the control room outputs, phones and at the left meter. The audible solo levels are then controlled by the CR and phones knobs. The solo levels appearing on the meters are not controlled by the CR and phones knob – you would not want that, anyway. What you do want to see is the actual channel level on the meters regardless of how loud the control room and phones output levels might be.

PFL means Pre-Fader Listen (post-EQ). With the PFL Solo switch engaged, solo will not be affected by a channel's mute switch position.



Remember, PFL taps the channel signal before the fader. If you have a channel's fader set way below "U" (unity gain), solo will not know that and will send a unity gain signal to the CR outs, phones output and meter display, which may raise some eyebrows.



As seen in the picture above, the ProFXI2v3+ has PFL solo switches to the right of the channel faders on chs. 1-11/12. There are no PFL solo switches on the ProFX6v3+ and ProFXI0v3+.

USB 3-4 Switch



When engaged, this switch overrides the respective inputs on the channel – chs. 3/4 on the ProFX6v3+, 7/8 on the ProFX10v3+, and 9/10 on the ProFX12v3+ – and allows the USB return – stereo playback of Spotify® or a DAW via the USB connection, for example – to flow through the signal path instead. Like any other input, this signal may also be EQ'd, sent to an aux bus, or mixed in with the other signals and assigned to a subgroup or the main outs.



There is additional information about the USB 3/4 Return Switch, including setup help and other tips and tricks in Appendix C on page 66.

Bluetooth Switch



Mixers can only accept one input per channel and the ProFXv3+ Series lineup is no different. This switch will engage the channel's pairing mode, allowing the mixer to be seen by other Bluetooth devices such as a phone or tablet.

If Bluetooth is disengaged, then the mixer will use the analog input signal. However, when connected via Bluetooth, then you have chosen to use the Bluetooth signal instead.

Pairing and Connecting – Press and hold the Bluetooth button for a few seconds to select it. The button will slow flash blue when selected. This is to indicate that the ProFXv3+ mixer and device are in pairing mode.

While the ProFXv3+ mixer is in pairing mode, simultaneously scan for Bluetooth devices on the phone or tablet. You should see ProFXv3+ appear in the “available devices” list. Select it. From there, the device should indicate that it is successfully connected. Additionally, the Bluetooth button on the mixer will be solid instead of flashing.



A previously paired device will auto reconnect if both the device and mixer are powered on and in range.



The Bluetooth may disconnect when affected by Electrostatic Discharge [ESD]. Manually reconnect the Bluetooth connection.

FX Footswitch Jack [ProFX10v3+ and ProFX12v3+]



This 1/4" TRS connector is where to connect your favorite footswitch. This allows you to easily mute or un-mute the internal effects at will. Any one-button on/off footswitch will work.

If the internal FX have already been muted with the internal FX mute switch, then the footswitch has no effect.

L/R Main Output Jacks



The main outputs provide a line-level signal that represents the end of the mixer chain, where the fully mixed stereo signal enters the real world. Connect these to the left and right inputs of your main power amplifiers, powered speakers, or serial effects processor (like a graphic equalizer or compressor/limiter).

The male XLR connectors provide a balanced line-level signal and is wired as follows, according to standards specified by the AES (Audio Engineering Society):

XLR Balanced Wiring:

- Pin 1 = Shield (ground)
- Pin 2 = Positive (+ or hot)
- Pin 3 = Negative (- or cold)

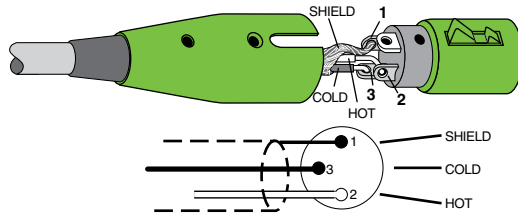

In addition to accepting balanced XLR connectors, the main outputs may also accept 1/4" connectors driven by balanced or unbalanced sources.

To connect balanced lines to these outputs, use a 1/4" Tip-Ring-Sleeve (TRS) plug. "TRS" stands for Tip-Ring-Sleeve, the three connection points available on a stereo 1/4" or balanced phone jack or plug. TRS jacks and plugs are used for balanced signals and are wired as follows:

1/4" TRS Balanced Mono Wiring:

- Sleeve = Shield
- Tip = Hot (+)
- Ring = Cold (-)

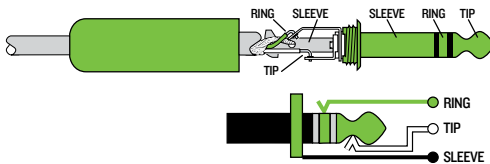

To connect unbalanced lines to these outputs, use a 1/4" mono (TS) phone plug, wired as follows:

1/4" TS Unbalanced Mono Wiring:

- Sleeve = Shield
- Tip = Hot (+)

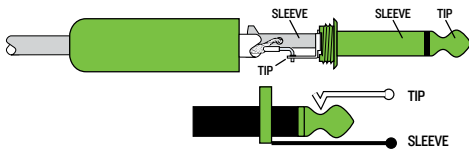

The XLR outputs are 6 dB hotter than the TRS outputs. When the meters read "0", the TRS outputs are at 0 dBu.

1/4" Headphone Output Jack



This 1/4" TRS connector supplies the output to stereo headphones. The volume is controlled via the phones knob.

Whenever a solo switch is engaged, you will only hear the soloed channel(s) in the headphones. This gives you the opportunity to audition the channels before they are added to the main mix. (Solo signals reaching the headphones are not affected by the channel level or main level, therefore turn down the phones level first, as soloed channels may be loud.)

The phones output follows standard conventions:

- Tip = Left channel
- Ring = Right channel
- Sleeve = Ground

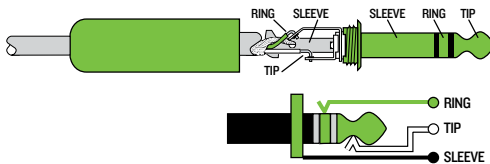

WARNING: The headphone amp is loud and can cause permanent hearing damage. Even intermediate levels may be painfully loud with some headphones. **BE CAREFUL!** Always turn the phones level control all the way down before connecting headphones or pressing a solo switch, or doing anything new that may affect the headphone volume. Then turn it up slowly as you listen carefully.



The signal leaving the phones jack may also accept a post-blend mix of the inputs and USB return if the "To Phones / Control Room" switch is engaged. More information about this switch (and the "Blend" knob) may be found on pages 30-31.

1/4" Control Room Jacks [ProFX10v3+ and ProFX12v3+]



These 1/4" jacks are usually patched to the inputs of a control room amplifier or a headphone distribution amplifier.

The control room outputs may also be used for other applications. The sound quality is just as impeccable as the main outputs. It may be used as an additional main mix output and this one will have its own level control. However, be aware that if a solo switch is engaged, the mix will be interrupted:



When a channel's solo switch is engaged, any existing selection is replaced by the solo signal, appearing at the control room outputs, phones and at the left meter. The audible solo levels are then controlled by the control room knob. The solo levels appearing on the meters are not controlled by the control room knob – you would not want that, anyway. What you do want to see is the actual channel level on the meters regardless of how loud the control room output level might be.



The signal leaving the CR outs may also accept a post-blend mix of the inputs and USB return if the "To Phones / Control Room" switch is engaged. More information about this switch (and the "Blend" knob) may be found on pages 30-31. Because there are no control room outputs on the ProFX6v3+, there is a "To Phones" only switch.

1/4" FX Send Jack [ProFX10v3+ and ProFX12v3+]



This 1/4" TRS line-level output may be used to feed an external effects processor (FX), such as a nice sound effect or delay unit. The output from this jack is an exact copy of what goes into the internal FX processor, being the careful mix of all channels whose aux FX control is turned to more than minimum.

(The processed output of the internal FX does not come out of this output, but is added internally to the main mix or monitor mix.)

The overall output level may be adjusted with the aux master FX knob. (This knob also affects the level going into the internal FX.)

The output is "post-fader," so any changes to the channel faders will also affect the level going to the external processor.

The processed output from the effects processor is usually returned to a spare channel, and you may carefully mix the original unprocessed channel (dry) and the processed channel (wet). Altering the original channel fader increases both the wet and dry signals and keeps them at the same delicate ratio. For example, the reverb remains at the same level relative to the original.

1/4" Mon Send Jack [ProFX12v3+]



Stage monitors allow the talented musicians in the band to hear themselves clearly on stage. This can be a good thing! The monitor mix may be carefully adjusted in level using the aux mon controls. These tap a portion of each channel's signal to provide a 1/4" TRS output here to feed external stage monitors. These could either be passive stage monitors powered by an external amplifier, or powered stage monitors with their own built-in amplifier.

The monitor signal is the sum (mix) of all the channels whose aux mon control is set to more than minimum. If they want "more me and less Brian," you may turn up their channel's aux mon control, and turn down Brian's.

The overall output level may be adjusted with the aux master mon knob. Additionally, you could add an external graphic EQ between this output and your powered monitors. This will allow you to adjust the EQ, and minimize the chance of feedback from nearby microphones.

The monitor output is not affected by the main mix fader or the channel faders. This allows you to set up the monitor mix and level just right, and not have it change when a channel fader or the main mix fader is adjusted. This is known as "pre-fader."

1/4" Sub Out Jacks [ProFX12v3+]

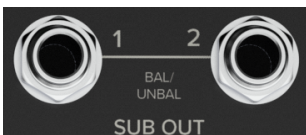

These 1/4" jacks are usually patched to the inputs of a multitrack deck or to secondary amplifiers in a complex installation.

48V Phantom Power Switch



Most modern professional condenser mics require 48V phantom power which lets the mixer send low-current DC voltage to the mic's electronics through the same wires that carry audio. (Semi-pro condenser mics often have batteries to accomplish the same thing.) "Phantom" owes its name to an ability to be "unseen" by dynamic mics (Shure SM57/SM58, for instance), which don't need external power and aren't affected by it anyway.

Press this switch in if your microphone requires phantom power. (Always check the position of this switch before connecting microphones.) The accompanying LED will illuminate red to indicate that phantom power is active. This is a global switch that affects all mic channels' XLR jacks at once.



Never plug single-ended (unbalanced) microphones, or ribbon mics into the mic input jacks if phantom power is on. Do not plug instrument outputs into the mic XLR input jacks with phantom power on unless you know for certain it is safe to do so. Be sure the main mix fader is turned down when connecting microphones to the mic inputs when phantom power is turned on to prevent pops from getting through to the speakers.

Power LED

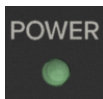

This LED will illuminate green when the mixer is turned on, as a reminder of how on it really is. If it is not on, then it is off, and the mixer becomes a rather nice weight for keeping your morning newspaper from blowing away in the wind.

If it does not turn on, make sure the power cord is correctly inserted at both ends, the local AC mains supply is active, and the power switch is on.

Main Meters



These peak meters are made up of two columns of twelve LEDs, with three colors to indicate different ranges of signal level, traffic light style. They range from -30 at the bottom, to 0 in the middle, to OL at the top.

When a channel is soloed [ProFX12v3+], the right meter shows no reading, and the left meter shows the level of that channel's signal level, pre-fader.

You can get a good mix with peaks flashing anywhere between -20 and +10 dB on the meters. Most amplifiers clip at about +10 dBu, and some recorders aren't so forgiving either. For best real-world results, try to keep your peaks between "0" and "+6." Remember, audio meters are just tools to help assure you that your levels are "in the ballpark." You don't have to stare at them (unless you want to).



The meters on the ProFX6v3+ are slightly different. It has only eight LEDs and they range from -24 to OL. Here you can get a good mix with peaks flashing anywhere between -12 and +8 dB on the meters.

Rude Solo LED [ProFX12v3+]



This large LED flashes red when one or more solo switches are engaged. This acts as a reminder that what you hear in the control room and headphones is the soloed channel(s). If you forget that you are in solo mode, you can easily be tricked into thinking that something is wrong with your mixer. Hence, the rude solo light. Please forgive its rudeness, it is only trying to help, and wants to be your friend.



Because there are no solo switches on the ProFX6v3+ and ProFX10v3+, there are no rude solo LEDs, either.

Aux Master Knobs [ProFX10v3+and ProFX12v3+]

ProFX10v3+

ProFX12v3+

These provide overall control over the aux mon and aux FX levels just before they are delivered to the aux mon and aux FX outputs, as well as internal FX in the case of the FX master.



Auxiliary is usually the control you turn up when the lead singer glares at you, points at his stage monitor, and sticks his thumb up in the air. (It would follow that if the singer stuck his thumb down, you'd turn the knob down, but that never happens.)



As seen to the left, the ProFX10v3 has a single FX master, the ProFX12v3 has a single aux master and FX master, and the ProFX6v3 does not have any aux masters.

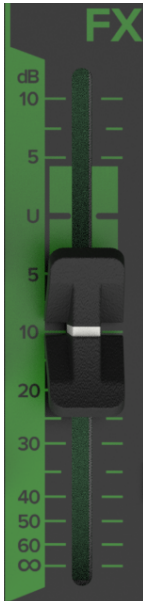

FX to Mon Knob [ProFX12v3+]



These knobs route the effects output to the monitors. Use the mon controls to provide effects to monitors. Slowly add effects to the monitors by turning the mon knobs clockwise. Use the aux master knobs (described on the previous page) to monitor the amount sent. The ProFX12v3+ has a single FX to mon knob.

FX Mute Switch



ProFX6v3+



ProFX10v3+



ProFX12v3+

When engaged, the internal effects processor is muted, and its output will not appear on the main mix or monitor mix. If this switch is not engaged, then the internal effects are set free and may be added as required to the main mix and/or monitor mix.

If this switch is not engaged, then the internal effects may be muted or un-muted with a footswitch [all ProFXv3+ mixers except the ProFX6v3+].

To Phones / Control Room Switch



By default, the control room and phones jacks output the 2-track LR mix (or soloed channels, if any are engaged). Push this switch in if you want to interrupt this signal and hear the blended signals instead.



Because there are no control room outputs on the ProFX6v3+, there is only a “To Phones” switch.

Control Room Knob [ProFX10v3+ and ProFX12v3+]



This knob is used to adjust the volume at the control room outputs, from ∞ (off) to maximum gain (max). Make sure that this knob is fully off [counter-clockwise] before selecting or adding a new source.



Because there are no control room outputs on the ProFX6v3+, there is no control room knob, either.

Phones Knob



This knob is used to adjust the volume at the phones output from ∞ (off) to maximum gain (max). Make sure that this knob is fully off [counter-clockwise] before selecting or adding a new source.



WARNING: The headphone amp is loud and can cause permanent hearing damage. Even intermediate levels may be painfully loud with some headphones. **BE CAREFUL!** Always turn the phones level control all the way down before connecting headphones or pressing a solo switch, or doing anything new that may affect the headphone volume. Then turn it up slowly as you listen carefully.

Blend Knob



With the adjacent (To Phones / Control Room) switch engaged, this knob sends a blend between all inputs (except for the 1/8" input) and the USB 1-2 Return to the Phones and Control Room outputs. As an added bonus, this is all at zero-latency!

Use this knob while recording overdubs alongside a pre-recorded track, for example.

Knob position (L, C, R):

- Full Left – Inputs = Full Volume
USB Return = No Volume
- Center – Inputs and USB Return = Equal Volume
- Full Right – Inputs = No Volume
USB Return = Full Volume

FX Knob / Fader



ProFX6v3+



ProFX10v3+



ProFX12v3+

Stereo signals come through this FX fader – FX knob on the ProFX6v3+ and ProFX10v3+ – and continue on to the main mix fader. They contain the effects' "wet" signals and are mixed together with the channels' "dry" original signals. Turned fully up, it provides 10 dB of additional gain, the "U" mark is unity gain, and fully down is off.

FX to Sub Switch [ProFX12v3+]

Fancy yourself adding FX to the sub group in addition to the main mix? Simply engage the I-2 switch to route FX to subs 1-2. It is located near the lower-right corner of the FX fader as seen in the ProFX12v3+ FX fader displayed above.

Sub I-2 Faders [ProFXI2v3+]



As you might expect, this fader controls the level of the signal sent to the sub out jacks.

All channels that are assigned to subs, not muted, and not turned fully down will appear at the sub outs.

The sub signal is off when the fader is fully down, the “U” marking is unity gain, and fully up provides 10 dB additional gain.

The sub fader works as a stereo pair – so sub 1 and 2 on a single fader – to easily maintain the left/right balance.

Sub I-2 Assign Switch [ProFXI2v3+]

One popular use of a subgroup is to use it as master fader for a group of channels on their way to the main mix fader.

Let’s say you have a drum kit hogging up five channels and you are going to want to control their group volume more conveniently. You do not want to try that with five hands or five fingers, so just unassign these channels from the main mix and reassign them to sub 1-2. Then engage the main mix L-R switch located near the lower-right corner of the sub I-2 fader as seen in the ProFXI2v3+ sub I-2 fader displayed above. Now you may ride the entire drum mix with a single fader – sub 1-2.

Sub I-2 Mute Switch [ProFXI2v3+]

When engaged, subgroups I-2 are muted, and its output will not appear on the main mix or monitor mix. If this switch is not engaged, then the subgroups are set free and may be added as required to the main mix and/or monitor mix. It is located conveniently above the sub I-2 fader as seen in the ProFXI2v3+ sub I-2 fader displayed above.

Main Mix Knob / Fader



ProFX6v3+



ProFX10v3+

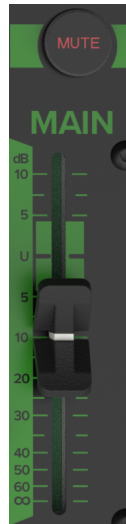

ProFXI2v3+

This stereo fader allows you to adjust the levels of the main mix signals sent to the XLR and 1/4" main line-level outputs.

This gives you the ultimate feeling of power and control over the sound levels sent to your audience. Adjust this control carefully, with your good eye on the meters to check against overloading, and your good ear to the levels to make sure your audience (if any) is happy.

The main mix signals are off with the fader fully down, the "U" marking is unity gain, and fully up provides 10 dB of additional gain. This additional gain will typically never be needed, but once again, it's nice to know that it's there. The fader is stereo, as it affects both the left and right of the main mix equally. This is the ideal control to slowly bring down at the end of a song (or quickly in the middle of a song if the need ever arises).

This control does not affect the aux / mon send or FX send outputs.



As seen to the left, the "Main Mix Fader" on the ProFX6v3+ and ProFX10v3+ is actually a "Main Mix Knob". But they behave similarly.

Main Mute / Break Switch

This important "take-a-break" switch quickly mutes all the microphones and line-level inputs to the main outs, cr outs and phones when the band is between sets. This will prevent protestors or rogue karaoke singers from storming the stage at the interval.

The monitor send and FX send are not affected. If there is no sound coming out of the system, be sure to check this switch first.

It is possible to play audio coming in from the computer via the USB inputs. For example, a soothing CD may be played while the band is off stage.

ProFX6v3+ – The adjacent break LED will illuminate as a reminder that the channels are muted.

It is located conveniently above the main mix level knob / fader as seen displayed above.

GIGFX+ Effects Engine



Preset Display

The Preset Display is one of the most vital features of the ProFXv3+ Series mixers. It displays information including (but not limited to) FX (and FX EQ), presets, and other parameters. Additional detail about all of these features may be found by continuing on.

Studio Command Control Knob

I wonder why they dismissed my suggestion for calling this the Studio Under Command Knob...? I mean, c'mon, right?! Turn the SUCK up/down to change parameters, push the SUCK in to select. I digress...

While the display presents the FX (and FX EQ), presets, and other parameters, it's the mixer's push-button rotary encoder that allows you to access these fields and change them.

Simply rotate the knob until the parameter you want to change is highlighted, push the encoder in, then make the changes. Again, additional details are coming soon. Please read on...

Back Button

The back arrow button is used as a navigation tool to go back and forth between the FX list and the current effect.

Number	Effect
1	DELAY
2	ECHO
3	SLAPBACK
4	HALL REVERB
5	ROOM REVERB
6	PLATE REVERB
7	CHORUS 1
8	CHORUS 2
9	FLANGER
10	DELAY + REVERB
11	DELAY + CHORUS
12	REVERB + CHORUS

Pressing and holding the back button will display all 12 effects into two columns of six. From here, one is able to rotate the endless Studio Command Control Knob to select one of the 12 preset effects.

The fun thing about these preset effects is what was mentioned above... they may be updated and tweaked to your heart's content! More on this starting on the following page.

The different available effects presets are shown in the table to the left and the currently selected effect preset is shown in the display. Only one preset may be selected at a time. Further details of each preset is explained on the following pages.

Factory Reset

When a ProFXv3+ mixer is factory reset, it restores most parameters back to their default. This includes all FX parameters and any stored presets. This is a permanent reset with no undo.

So how does one place the mixer back to its factory default? Press and hold the Studio Command Control Knob AND Back Button simultaneously until the display shows the Mackie Running Man.



Doing a factory reset and resetting the FX EQ (see page 41) are not the same thing and will result in different settings.

FX Section

The ProFXv3+ FX engine is incredibly powerful and packed with a ton of features.

There are 12 effects to choose from, but each one of those may be manipulated and tweaked to your inclination.

Before diving in, though, let's take a look at a table of the 12 effect types with a description of each preset and some examples.

Note that the effects are presented in four sets of three:

- Effects 1-3 – Delays – **Virtual Knob Color = blue**
- Effects 4-6 – Reverbs – **Virtual Knob Color = red**
- Effects 7-9 – Modulations – **Virtual Knob Color = purple**
- Effects 10-12 – Multi-purpose – **Virtual Knob Color = yellow**

Number	Title	Description	Example of its use
1	Delay	This effect repeats the source signal in even increments, later in time, defined by the time setting. The feedback control increases / decreases the amount of repeats.	This works best with full, up-beat music like rock where the delay needs to cut through the mix.
2	Echo	This type of delay effect repeats the source signal twice. It has a characteristic of a double repeat like a voice reflecting off the walls of a canyon. The timing and amount of repeats are defined by the time and feedback settings.	Also known as Slap Back Echo, use it to make a vocal or guitar stand out in the mix without extra volume.
3	Slapback	This effect provides a single or double, relatively rapid delay of the original signal with minimal repeats through the feedback setting.	Slapback is generally used to mimic vocals – and sometimes drums – on '50s-era rock 'n roll.
4	Hall Reverb	This reverb is characterized by its large, spacious sound, long pre-delay and vibrant tone.	Adds life to acoustic instruments and vocals from solos to full-on symphonies and choirs.
5	Room Reverb	This preset features a medium sized room sound, with just enough enhancement of the lower mids to produce a warm tone.	Useful for any instrument or vocal source to sound like it's in an acoustic space that is like a recording studio. Try running the snare, horn section, or acoustic guitar on this one!
6	Plate Reverb	Plate reverbs emulate vintage mechanical reverberation that is generated with a metal plate. Its sound is characterized by lots of early reflections and no pre-delay.	Perfect for adding a long sustain to percussion like tambourine, hand-claps, and backup vocals.
7 8	Chorus 1 Chorus 2	These presets provide a soft, ethereal sweeping effect that is useful for thickening and for making a particular sound pop out of the mix.	Perfect for enhancement of electric and acoustic guitar and bass, or to add a dramatic effect to vocals, particularly group harmonies and choirs.
9	Flanger	The flange effect is a modulated delay with feedback (and shorter delay times than a chorus), which creates the characteristic “whooshing” sound often used to describe the flange sound.	Check out the electric rhythm guitar on the song “Barracuda” by Heart.
10	Delay + Reverb	Don't choose delay, don't choose reverb! Get the best of both worlds with effects preset #10!	Useful for bands that employ the alternative rock, shoegaze and/or experimental rock sound.
11	Delay + Chorus	Don't choose delay, don't choose chorus! Get the best of both worlds with effects preset #11!	Pink Floyd guitarist, David Gilmour, often used this effect in his setup.
12	Reverb + Chorus	Don't choose reverb, don't choose chorus! Get the best of both worlds with effects preset #12!	Really thicken things up with this preset. The chorus creates a slightly detuned version of the signal blended with the normal signal, while the reverb emulates the bouncing of sound waves across different-sized venues.

Delay

The preset display should now show the current parameters of the delay effect:

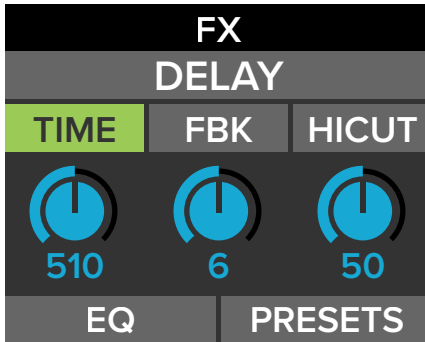

Delay allows adjustment of the delay effect. ProFXv3+ Series mixers come with three delays to choose from: delay, echo and slapback.

The delay parameters that may be changed on each include time, feedback and hi-cut. Additionally, each effect has an EQ section, as well as a spot to save and load custom FX via presets.

Rotate the Studio Command Control Knob between the three selections located above the virtual knobs. When time, feedback or hi-cut is highlighted, simply push the knob in to select the parameter.

Notice how hi-cut is highlighted in the first screenshot below. But in the second screenshot, hi-cut has been selected (by pressing in the Studio Command Control Knob), resulting in the text of the parameter and corresponding border turning green.

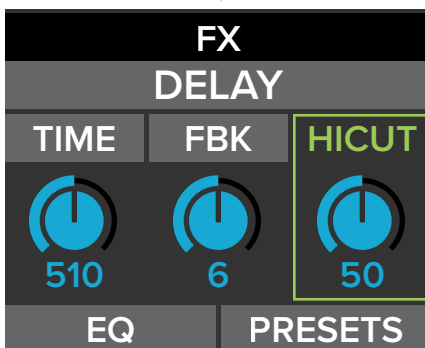
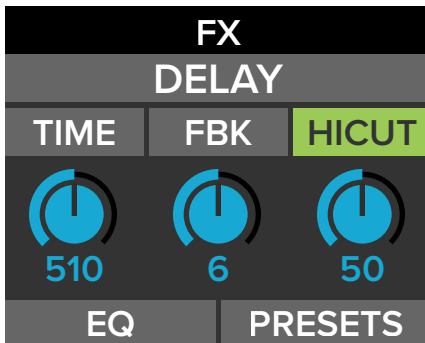

From here, rotate the knob again to tweak the selected parameter's value to your liking. Once a desired setting has been reached, push the knob in again to confirm.

Time – This knob sets the current delay time in milliseconds, from 20 ms to 1000 ms.

Feedback – This controls how much of the delayed signal is routed back to the input of the delay section to create multiple echoes. Each time the signal is fed back, the delayed signal becomes quieter (so the echo won't go on forever). It ranges from 0 to 13.

Hi Cut – This applies a low-pass filter to the delayed signal and rolls off the higher frequencies on the output. It ranges from 0 to 100.

FX EQ

Now let's take a look at the EQ section. As before, rotate the knob until EQ is highlighted, then push in to reveal the EQ screen.

The EQ parameters that may be changed here include frequency, width, gain, LPF and HPF. Now keep in mind that this is the EQ of the selected effect!

As before, rotate the Studio Command Control Knob between the five selections located above the virtual knobs. When frequency, width, gain, LPF or HPF is highlighted, simply push the knob in to select the parameter.

Notice how LPF is highlighted in the first screenshot below. But in the second screenshot, LPF has been selected (by pressing in the Studio Command Control Knob), resulting in the value of the parameter and corresponding border turning green.

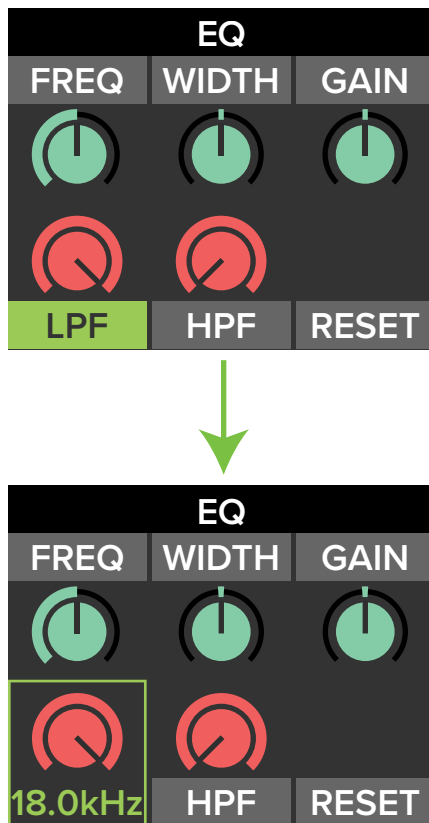

From here, rotate the knob again to tweak the selected parameter's value to your liking. Once a desired setting has been reached, push the knob in again to confirm.

Frequency – This parameter's value determines the frequency of the selected effect, ranging from 400 Hz to 16.0 kHz.

Width [aka "Q"] – The Q control adjusts the bandwidth of a filter. However, the Q value itself is dimensionless; it has no unit of measurement. Some equalizers use the fractional bandwidth of the filter, measured in octaves, to express this parameter. The two parameters are inversely related; a high Q value corresponds to a small fractional bandwidth. The following table lists some equivalent Q and fractional bandwidth values. It ranges from 0.5 to 3.

Q	Bandwidth (Octave)
0.7	2
1.414	1
2.145	2/3
2.871	1/2

Gain – This parameter's value determines the amount of gain applied to the selected effect. It ranges from -8 dB to +8 dB.

LPF – Low-pass filters are utilized to cut out high frequencies. It ranges from 6.0 kHz to 18.0 kHz.

HPF – High-pass filters are utilized to cut out low frequencies. It ranges from 80 Hz to 600 Hz.

Before moving on to 'Presets' and 'Reset', let's take a quick peek at the parameters of delay, echo and slapback, as well as their EQ settings.

Delay Parameters and Values

Parameter	Low Value	High Value	Default	Increments
Time	20 ms	1000 ms	363 ms	±10 ms
Feedback	0	13	2	±1
Hi Cut	0	100	78	±1
EQ	-	-	-	-
Frequency	400 Hz	16.0 kHz	7.9 kHz	Variable
Width (Q)	0.5	3.0	0.5	±0.1
Gain	-8 dB	+8 dB	+1 dB	±1 dB
LPF	6.0 kHz	18.0 kHz	6.0 kHz	±0.1-0.2 kHz
HPF	80 Hz	600 Hz	120 Hz	±1-10 Hz

Echo Parameters and Values

Parameter	Low Value	High Value	Default	Increments
Time	140 ms	1000 ms	553 ms	±10 ms
Feedback	0	17	6	±1
Hi Cut	0	100	77	±1
EQ	-	-	-	-
Frequency	400 Hz	16.0 kHz	1.0 kHz	Variable
Width (Q)	0.5	3.0	2.0	±0.1
Gain	-8 dB	+8 dB	±0 dB	±1 dB
LPF	6.0 kHz	18.0 kHz	7.0 kHz	±0.1-0.2 kHz
HPF	80 Hz	600 Hz	100 Hz	±1-10 Hz

Slapback Parameters and Values

Parameter	Low Value	High Value	Default	Increments
Time	80 ms	400 ms	96 ms	±3-4 ms
Feedback	0	2	0	±1
Hi Cut	0	100	100	±1
EQ	-	-	-	-
Frequency	400 Hz	16.0 kHz	1.0 kHz	Variable
Width (Q)	0.5	3.0	2.0	±0.1
Gain	-8 dB	+8 dB	±0 dB	±1 dB
LPF	6.0 kHz	18.0 kHz	12.1 kHz	±0.1-0.2 kHz
HPF	80 Hz	600 Hz	80 Hz	±1-10 Hz

FX Presets

The presets section allows you to save up to six settings to memory that may be recalled at a later time. No more having to reset parameters upon every power-up!

As was done previously, simply rotate the Studio Command Control Knob until 'Presets' is highlighted (first screenshot below). Next, rotate the knob to switch between the six presets followed by pushing the knob in to select it (second screenshot below).

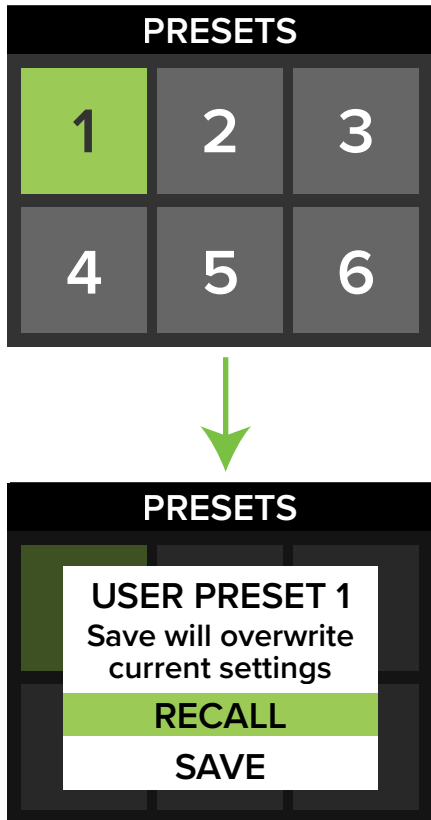

As one might suspect by now, rotating the knob switches between 'Recall' and 'Save' and pushing the knob in chooses the currently highlighted selection.



Save – Select this to save the current settings to the corresponding preset.

Please be aware that the new settings will replace the currently saved settings.

Recall – Select this to recall the settings of the corresponding preset.

FX EQ Reset

A few pages ago, we were looking at the FX EQ section. In addition to the changeable parameters – frequency, width, gain, LPF and HPF – a sixth option (located in the lower-right corner) may also be accessed and selected: Reset



Once 'Reset' is highlighted, push the control knob in to reset all EQ settings. It is a convenient way to start with a fresh slate.

Resetting any FX EQ results in the following parameter values:

- Frequency – 1.0 kHz
- Width – 2.0
- Gain – ± 0 dB
- LPF – 18.0 kHz
- HPF – 80 Hz

NOTE Resetting the FX EQ and doing a factory reset (see page 34) are not the same thing and will result in different settings.

Now that you're familiar with how to select an effect and tweak the parameters' values to your liking, we're going to look at the remaining effects, their settings and their low, high and default values, starting with the three reverbs (Hall, Room and Plate).

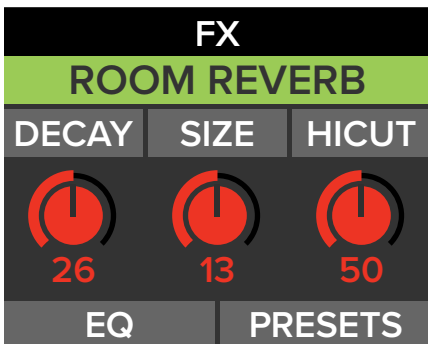

Decay – This knob represents the decay time of the reverb. The range will vary depending on the reverb chosen.

Size – This knob represents the amount of desired reverb (or “the size of the room”). While the range will vary depending on the reverb chosen, 0 means no reverb and fully clockwise is max reverb.

Hi Cut – This applies a low-pass filter to the delayed signal and rolls off the higher frequencies on the output. It ranges from 0 to 100.

Hall Reverb Parameters and Values

Parameter	Low Value	High Value	Default	Increments
Decay	0	60	15	±1
Size	0	15	12	±1
Hi Cut	0	100	0	±1
EQ	-	-	-	-
Frequency	400 Hz	16.0 kHz	1.0 kHz	Variable
Width (Q)	0.5	3.0	2.0	±0.1
Gain	-8 dB	+8 dB	+0 dB	±1 dB
LPF	6.0 kHz	18.0 kHz	8.7 kHz	±0.1-0.2 kHz
HPF	80 Hz	600 Hz	132 Hz	±1-10 Hz

Room Reverb Parameters and Values

Parameter	Low Value	High Value	Default	Increments
Decay	0	52	3	±1
Size	0	25	12	±1
Hi Cut	0	100	0	±1
EQ	-	-	-	-
Frequency	400 Hz	16.0 kHz	1.0 kHz	Variable
Width (Q)	0.5	3.0	2.0	±0.1
Gain	-8 dB	+8 dB	+0 dB	±1 dB
LPF	6.0 kHz	18.0 kHz	13.3 kHz	±0.1-0.2 kHz
HPF	80 Hz	600 Hz	190 Hz	±1-10 Hz

Plate Reverb Parameters and Values

Parameter	Low Value	High Value	Default	Increments
Decay	0	65	35	±1
Size	0	40	35	±1
Hi Cut	0	100	20	±1
EQ	-	-	-	-
Frequency	400 Hz	16.0 kHz	400 Hz	Variable
Width (Q)	0.5	3.0	2.5	±0.1
Gain	-8 dB	+8 dB	+8 dB	±1 dB
LPF	6.0 kHz	18.0 kHz	8.2 kHz	±0.1-0.2 kHz
HPF	80 Hz	600 Hz	80 Hz	±1-10 Hz

Now a look at the three modulation effects (Chorus 1, Chorus 2 and Flanger).

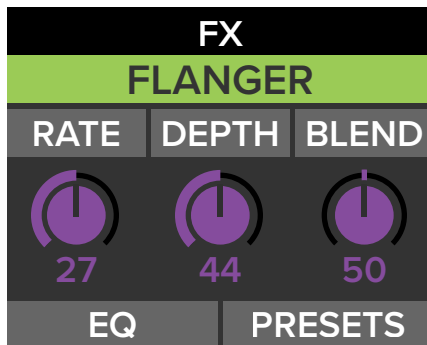

Rate – This knob sets the speed of the delay modulation. The range will vary depending on the effect chosen.

Depth – This knob sets the depth of the delay modulation, from 1 to 10. The range will vary depending on the effect chosen.

Blend – The Blend knob essentially works as a level control in that you determine how much the sound effect dominates the mix.

Chorus 1 Parameters and Values

Parameter	Low Value	High Value	Default	Increments
Rate	0	54	12	±1
Depth	16	73	28	±1
Blend	0	100	59	±1
EQ	-	-	-	-
Frequency	400 Hz	16.0 kHz	1.0 kHz	Variable
Width (Q)	0.5	3.0	2.0	±0.1
Gain	-8 dB	+8 dB	+0 dB	±1 dB
LPF	6.0 kHz	18.0 kHz	10.0 kHz	±0.1-0.2 kHz
HPF	80 Hz	600 Hz	120 Hz	±1-10 Hz

Chorus 2 Parameters and Values

Parameter	Low Value	High Value	Default	Increments
Rate	16	93	16	±1
Depth	30	150	36	±1
Blend	0	100	100	±1
EQ	-	-	-	-
Frequency	400 Hz	16.0 kHz	3.0 kHz	Variable
Width (Q)	0.5	3.0	3.0	±0.1
Gain	-8 dB	+8 dB	-8 dB	±1 dB
LPF	6.0 kHz	18.0 kHz	8.7 kHz	±0.1-0.2 kHz
HPF	80 Hz	600 Hz	334 Hz	±1-10 Hz

Flanger Parameters and Values

Parameter	Low Value	High Value	Default	Increments
Rate	0	100	10	±1
Depth	10	150	62	±1
Blend	0	100	100	±1
EQ	-	-	-	-
Frequency	400 Hz	16.0 kHz	7.6 kHz	Variable
Width (Q)	0.5	3.0	2.0	±0.1
Gain	-8 dB	+8 dB	-1 dB	±1 dB
LPF	6.0 kHz	18.0 kHz	18.0 kHz	±0.1-0.2 kHz
HPF	80 Hz	600 Hz	90 Hz	±1-10 Hz



The rate (Hz) and depth (ms) determine how many cycles per second the chosen effect oscillates. However, the rate and depth of Chorus 1, Chorus 2 and Flanger is expressed as 0.1x Hz / ms which translates the value that the processor utilizes. An easy way to understand the value is to take the number below the virtual knob and “move” the decimal one point to the left (or multiply by 0.1).

For example, if rate is displayed as 37, then it's really 3.7 Hz.

Lastly, onto the final three multi-purpose effects (Delay + Reverb, Delay + Chorus, and Reverb + Chorus).

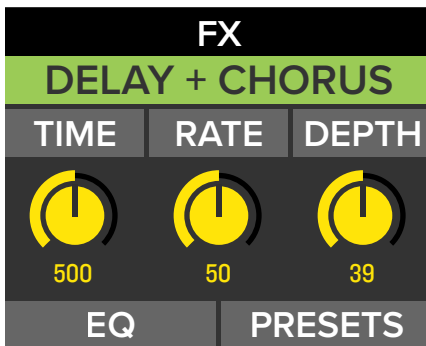

Time – This knob sets the current delay time in milliseconds, from 20 ms to 1000 ms.

Rate – This knob sets the speed of the modulation. The range will vary depending on the effect chosen.

Depth – This knob sets the depth of the delay modulation. The range will vary depending on the effect chosen.

Decay – This knob represents the decay time of the reverb, ranging from 0 to 60.

Size – This knob represents the amount of desired reverb (or “the size of the room”), ranging from 0 (no reverb) to 15 (max reverb).

Delay + Reverb Parameters and Values

Parameter	Low Value	High Value	Default	Increments
Time	20 ms	1000 ms	196 ms	±9-10 ms
Rate	16	73	26	±1
Depth	0	100	8	±1
EQ	-	-	-	-
Frequency	400 Hz	16.0 kHz	6.8 kHz	Variable
Width (Q)	0.5	3.0	2.1	±0.1
Gain	-8 dB	+8 dB	+2 dB	±1 dB
LPF	6.0 kHz	18.0 kHz	12.6 kHz	±0.1-0.2 kHz
HPF	80 Hz	600 Hz	88 Hz	±1-10 Hz

Delay + Chorus Parameters and Values

Parameter	Low Value	High Value	Default	Increments
Time	20 ms	1000 ms	196 ms	±9-10 ms
Rate	0	73	12	±1
Depth	16	100	40	±1
EQ	-	-	-	-
Frequency	400 Hz	16.0 kHz	1.0 kHz	Variable
Width (Q)	0.5	3.0	2.0	±0.1
Gain	-8 dB	+8 dB	±0 dB	±1 dB
LPF	6.0 kHz	18.0 kHz	6.0 kHz	±0.1-0.2 kHz
HPF	80 Hz	600 Hz	80 Hz	±1-10 Hz

Reverb + Chorus Parameters and Values

Parameter	Low Value	High Value	Default	Increments
Decay	0	60	10	±1
Size	0	15	6	±1
Rate	0	54	33	±1
EQ	-	-	-	-
Frequency	400 Hz	16.0 kHz	415 Hz	Variable
Width (Q)	0.5	3.0	2.0	±0.1
Gain	-8 dB	+8 dB	-5 dB	±1 dB
LPF	6.0 kHz	18.0 kHz	10.0 kHz	±0.1-0.2 kHz
HPF	80 Hz	600 Hz	108 Hz	±1-10 Hz



The rate (Hz) and depth (ms) determine how many cycles per second the chosen effect oscillates. However, the rate and depth of the two chorus modulation effects is expressed as 0.1x Hz / ms which translates the value that the processor utilizes. An easy way to understand the value is to take the number below the virtual knob and “move” the decimal one point to the left (or multiply by 0.1). For example, if rate is displayed as 37, then it’s really 3.7 Hz.

...and this would be my personal favorite feature of the ProFXv3+ Mixer Series: Watering. That’s right, with 21st century technology, we have figured out a way to “stuff” extra features into our mixers.

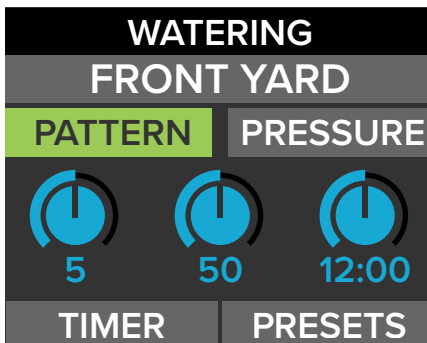

The ProFXv3+ mixer allows you to water things. This could be anything from household plants and flowers (indoor and outdoor), and full lawns/grass all the way up to patios, decks, driveways, cars/boats, dogs, and much more! In the example above, we have selected the front yard.

First things first – connect hoses to the output jacks. This could be the main outs, control room, sub outs, mon send, FX send, and/or the phones jack. Easy twist-and-turn to connect.

Pattern – This knob sets the watering pattern from 1 to 10. The number and its respective watering pattern is displayed below.

Number	Pattern
1	SHOWER
2	JET
3	FLAT
4	CENTER
5	CONE
6	FULL
7	MIST
8	STREAM
9	VERTICAL
10	1/2 VERTICAL

Pressure – This knob controls the flow of water from 0 (Off) to 100 (Max). As you might expect, the higher the number the greater the water pressure.

Timer – This knob sets a timer for when you want the hose(s) to run... and for how long. It is on a 24-hour clock and the default is noon.

Watering Parameters and Values

Parameter	Low Value	High Value	Default	Increments
Pattern	1 (SHOWER)	10 (1/2 VERTICAL)	5 (CONE)	±1
Pressure	0	100	50	±1
Timer	-	-	12:00 pm	±1 minute

Recording Mode

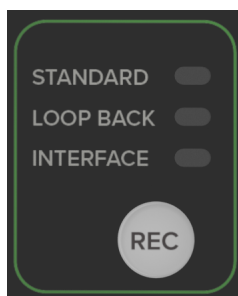

ProFXv3+ Series mixers were designed with you, the recording artist, in mind. Press the REC button to toggle between the three recording modes. The currently selected choice will illuminate green.

The three modes –and what they mean – are listed below:

Standard – Captures a complete recording of the main mix to computer, including GigFX+ effects and tone-shaping EQ.

Loopback – Includes computer audio to the recording. This is great for video game streams or playing music over backing tracks, for example.

Interface – Sends untouched audio from channels 1 and 2 directly to the computer – without effects – for the cleanest recording possible.

Hookup Diagrams

Hookup Diagrams > Typical Live Sound System

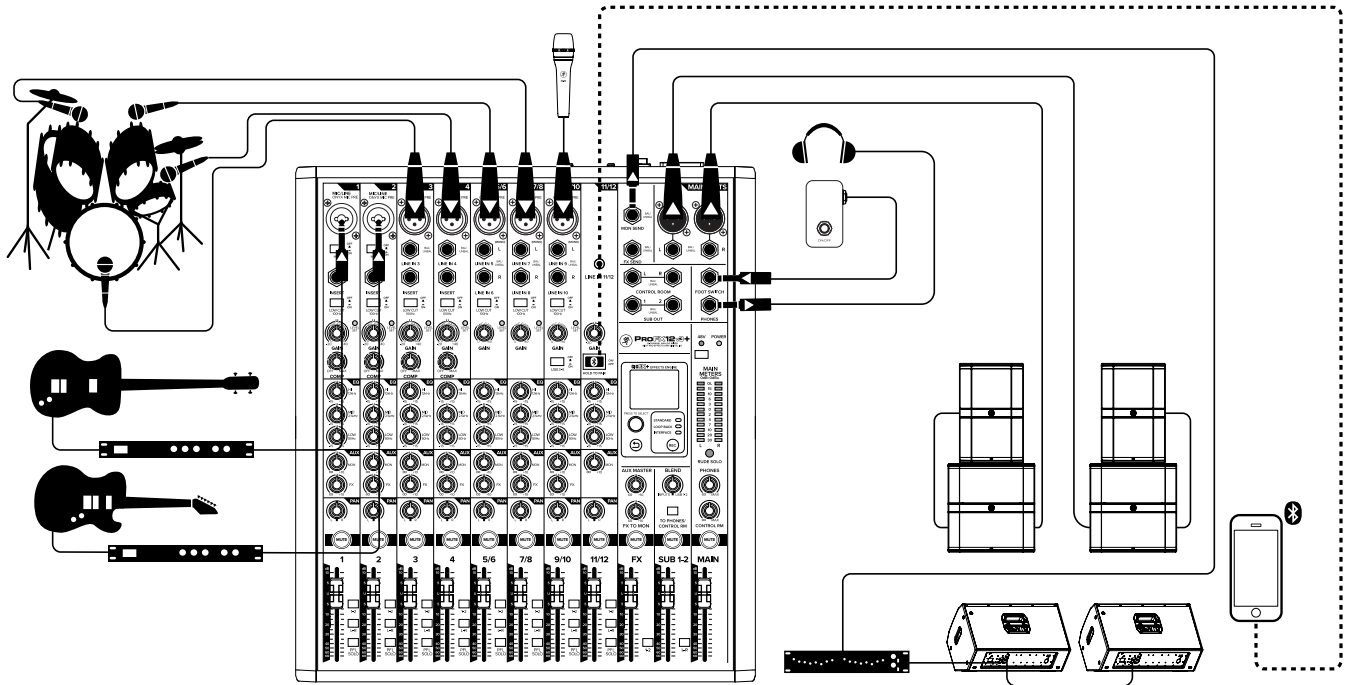

This diagram shows a guitar and bass attached to the channel 1 and 2 line-level inputs, each via a mono effects processor. The Hi-Z switch is engaged on both channels. A mic'd up drum kit utilizes the next four channels of the mixer. A microphone is connected to the following channel and will handle lead vocal duties. A phone is connected to the last channel on the board via Bluetooth.

DRM18S powered subwoofers are connected to the left and right main outputs. Those are then connected to a pair of SRM215 | V-Class loudspeakers to complete the PA. Two SRM212 | V-Class loudspeakers are also set up as stage monitors and connect to the mixer's aux (monitor) output via graphic EQ. The aux mon controls of each channel allow you to create a stage monitor mix as desired. Headphones are used for monitoring and a footswitch allows you to mute/unmute the internal effects as desired.

It's not shown, but a laptop may connect to the USB port on the rear panel of the mixer. It allows the performance to be recorded to a DAW, as well as playback from the computer to the main mix.

Hookup Diagrams > Typical Recording System

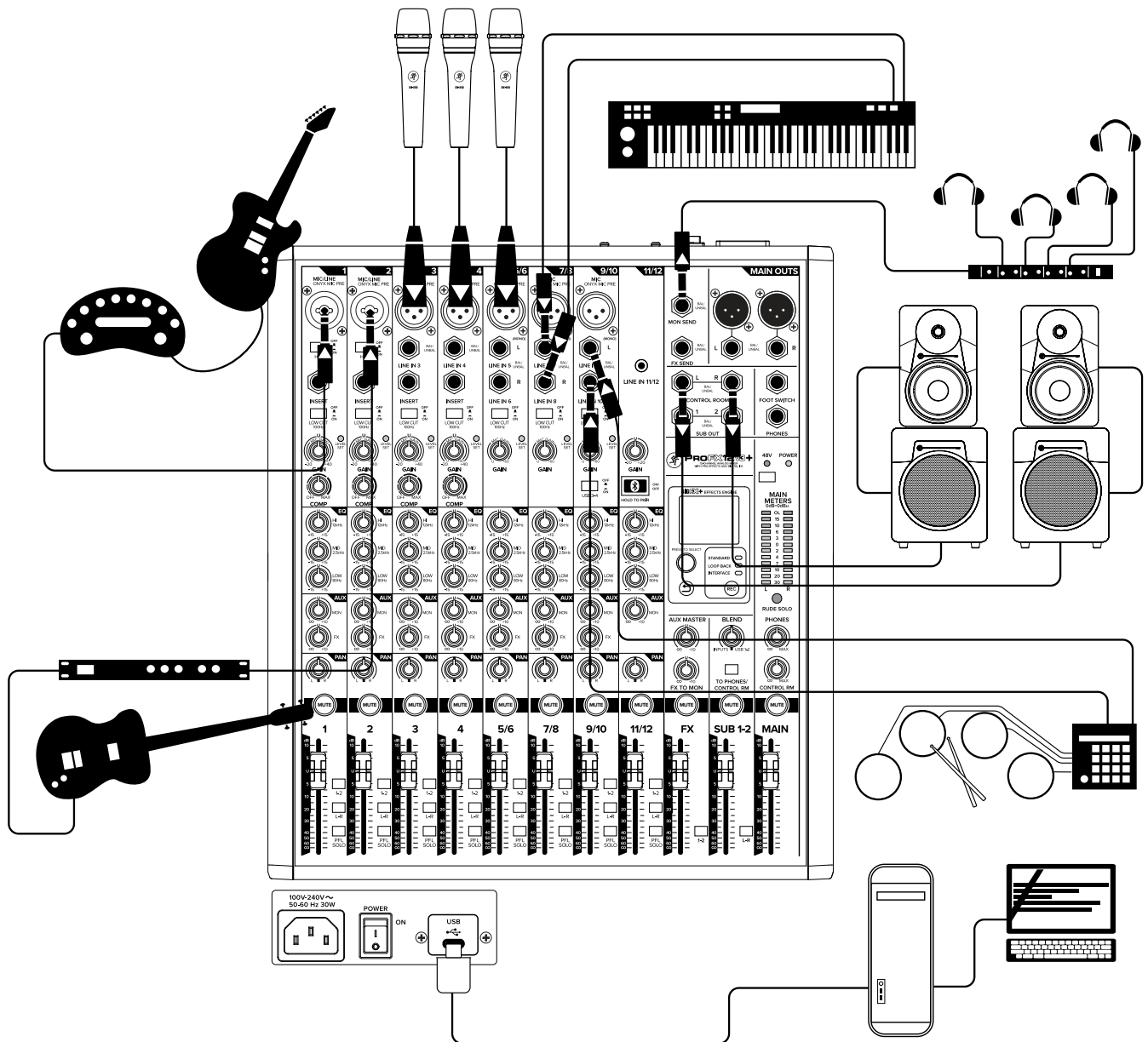

Like the previous hookup diagram, this one also starts with a guitar and bass attached to the channel 1 and 2 line-level inputs, each via a mono effects processor. The Hi-Z switch is engaged on both channels. Microphones are attached to channels 3 through 5/6, a keyboard to stereo channels 7/8, and an electronic drum kit to stereo channels 9/10.

MR Series powered reference subwoofers and monitors are connected to the left and right control room outputs for careful and accurate monitoring of the performance. Headphones connected to the aux (monitor) out via a headphone amp are available for the talent to utilize when tracking.

A desktop computer connects to the USB port to record the mix to the DAW, as well as playback from the DAW.

Appendix A : Service Information

Troubleshooting

If you think your Mackie product has a problem, please check out the following troubleshooting tips and do your best to confirm the problem. Visit the Support section of our website (www.mackie.com) to get some ideas or contact our technical support heroes. You may find the answer to the problem without having to send your Mackie product away.

Here are some useful tips that could correct any of the issues outlined below (or possibly any other issue that we haven't yet discovered):

Level setting procedure. If you are having any sound (or non-sound) issues, try following the level setting procedure [page 8] to verify that all of the volume controls in the system are properly adjusted.

There are no user serviceable parts. If none of these tips work, please refer to "Repair" on the next page to find out how to proceed.

No Power

- Our favorite question: Is it plugged in? Make sure the AC outlet is live [check with a tester or lamp].
- Our next favorite question: Is the power switch on? If not, try turning it on.
- Make sure the line cord is securely seated in the line cord socket and plugged all the way into the AC outlet.
- Is the power LED on the top panel illuminated? If not, make sure the AC outlet is live. If so, refer to "No sound" below.
- The internal AC line fuse may be blown. This is not a user serviceable part. If you suspect the AC line fuse is blown, please see the "Repair" section next.
- Are all the lights out in town? If so, contact the local power company to get power restored.

No Sound

- Are all the connections good and sound? Make sure all of the connecting cables work and are securely connected at both ends. Try the same source signal in another channel, set up exactly like the suspect channel. Make sure the master volume level is turned up sufficiently to drive the inputs of the speakers.
- Is the level knob for the input source turned all the way down? Verify that all the volume controls in the system are properly adjusted. Look at the level set LEDs and meters to ensure that the mixer is receiving a signal.
- Make sure the input source is not muted or has a processor loop engaged. If you find something like this, make sure the level is turned down before disengaging the offending switch.
- Is the main level turned up?
- Unplug anything from the other line-level outputs, such as monitor out, just in case one of the external pieces has a problem.
- Make sure that you are not overdriving the amplifiers. Check the loudspeaker average load impedance is not less than the minimum the amplifier can handle. Check the speaker wiring.
- Is the signal source powered on? Is it working (and making union scale)?

Noise / Hum

- Are the EQs set to reasonable levels?
- Are any aux returns maxed out?
- Are you using unbalanced cables? Swap them out with balanced cables to see if that fixes the problem.
- Try the same source signal in another channel, set up exactly like the suspect channel.
- Try disconnecting the cable connected to the input jack. If the noise disappears, it could be a “ground loop,” rather than a problem with the mixer.
- Turn the input gains down one-by-one. If the offending noise disappears, it’s either that input or whatever is plugged into it. If you unplug the whatever-is-plugged-into-it and turn the input gain back up and the noise is gone, it’s from your whatever.
- Is phantom power required for the microphone?
- Whenever possible, plug all the audio equipment’s line cords into outlets which share a common ground. The distance between the outlets and the common ground should be as short as possible.
- Make sure none of the signal cables are routed near AC cables, power transformers, or other EMI-inducing devices.
- Is there a light dimmer or other SCR-based device on the same AC circuit as the mixer?
Use an AC line filter or plug it into a different AC circuit.

Other Issues

- Bluetooth Blues?
 - Restart the Bluetooth device. Completely power it down, then power it back up.
 - Restart the mixer. A simple reboot can sometimes work great wonders.
- Using a Windows-driven computer and need to install the Mackie USB Driver?
 - Go to mackie.com and look for the file named ‘USB Driver Installation Instructions’.
- Need answers about ASIO?
 - There is a lot of great information here, including ASIO driver downloads, FAQs, troubleshooting, a forum and more! Please review before calling Technical Support:
 - o <http://www.asio4all.org/>
- Other issues?
 - Please email or call Technical Support if you are having any other issue not listed here:
 - o mackie.com/support-contact
 - o 1-800-898-3211

Microphone Stand

The bottom panel of the ProFX6v3+ has three non-threaded holes that allow it to be fitted with an optional microphone stand adapter. This lets you support the mixer on a standard mic stand, and adjust its height and level to whatever suits your strangely-complex set of preferences.

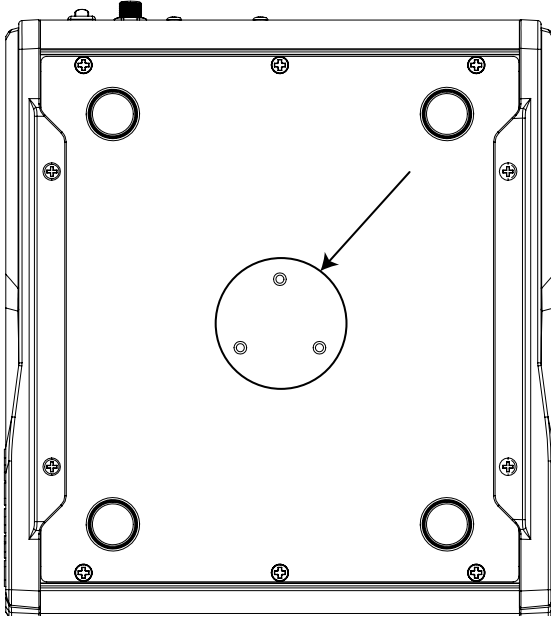

1. Order the Atlas AD-11B mic stand adapter available from many a fine music store. (It is made and distributed by Atlas Sound.)
2. Use three Trilobular thread rolling screws 6-32 x 1/4" long to secure the adapter to the bottom of the mixer [see below].



Do not use screws longer than 1/4" as these could damage the circuit boards.
Do not use screws shorter than 1/4" or the adapter will not be securely fixed to the mixer.

Repair

For warranty service, refer to the warranty information on page 62.

Non-warranty service for Mackie products is available at a factory-authorized service center. To locate the nearest service center, visit www.mackie.com, click "Support" and select "Service Center Locator". Service for Mackie products living outside the United States can be obtained through local dealers or distributors.

If you do not have access to our website, you can call our Tech Support department at 1-800-898-3211, Monday-Friday during normal business hours, Pacific Time, to explain the problem. Tech Support will tell you where the nearest factory-authorized service center is located in your area.

Appendix B : Technical Information

Specifications

Noise Characteristics

Equivalent Input Noise (EIN) (150 Ω Source Impedance, 20 Hz to 20 kHz)

Mic in to Insert Send out, max gain: -126 dBu

Residual Output Noise

All outputs, master levels off, all channel levels off: -95 dBu

All outputs, master levels unity, one channel level unity: -80 dBu

Frequency Response

Mic input to any output (gain at unity, +0 dB / -1 dB): 20 Hz to 30 kHz

Distortion (THD+N)

(22 Hz to 80 kHz bandwidth)

Mic in to Main Out (+4 dBu output): <0.02%

Attenuation and Crosstalk

Adjacent Inputs @1 kHz: -90 dB

Inputs to Outputs @1 kHz: -80 dB

Fader Off @1 kHz: -75 dB

Mute Switch / Break Switch Mute @ 1 kHz : -90 dB

Common Mode Rejection Ratio (CMRR)

Mic in to Main out, max gain, 1 kHz: 70 dB

Maximum Levels

All inputs: +22 dBu

Main Mix XLR: +28 dBu

All other outputs: +22 dBu

Impedances

Mic in:	3.3 kΩ
Channel Insert Return:	10 kΩ
All other inputs:	≥20 kΩ
Phones out:	25 Ω
All other outputs:	120 Ω Unbalanced, 240 Ω Balanced

Equalization

ProFX6v3+

Low:	±15 dB @ 80 Hz
High:	±15 dB @ 12 kHz
Low Cut Filter:	18 dB/octave @ 100 Hz

ProFX10v3+ • ProFX12v3+

Low:	±15 dB @ 80 Hz
Mid:	±15 dB @ 2.5 kHz
High:	±15 dB @ 12 kHz
Low Cut Filter:	18 dB/octave @ 100 Hz

Maximum Voltage Gain (EQ Flat)

Mic Input Channel to...

Insert Output:	60 dB
1/4" Main Output:	80 dB
XLR Main Output:	86 dB
1/4" Sub Output:	80 dB
Aux Output (Pre-Fader):	80 dB
Aux Output (Post-Fader):	90 dB
FX Send:	90 dB
FX Send [ProFX10v3]:	80 dB
USB Output:	70 dB

Mono Line Input Channel to...

Insert Output:	40 dB
1/4" Main Output:	60 dB
XLR Main Output:	66 dB
1/4" Sub Output:	60 dB
Aux Output (Pre-Fader):	60 dB
Aux Output (Post-Fader):	70 dB
FX Send:	70 dB
FX Send [ProFX10v3]:	60 dB
USB Output:	50 dB

Stereo Line Input Channel to...

1/4" Main Output:	20 dB
XLR Main Output:	26 dB
1/4" Sub Output:	20 dB
Aux Output (Pre-Fader):	20 dB
Aux Output (Post-Fader):	30 dB
FX Send:	30 dB
FX Send [ProFX10v3]:	20 dB
USB Output:	10 dB

1/8" Input to...

1/4" Main Output:	40 dB
XLR Main Output:	46 dB
1/4" Sub Output:	40 dB
Aux Output (Pre-Fader):	40 dB
Aux Output (Post-Fader):	50 dB
FX Send:	50 dB
FX Send [ProFX10v3]:	40 dB
USB Output:	30 dB

USB Input to...

XLR Main Output:	46 dB
------------------------	-------

Digital Effects

Number of Presets:	24
--------------------------	----

Meters

Main L/R Mix

ProFX6v3+ - Two columns of 8 segments each: OL, +14, +8, +4, 0 (0 dBu), -4, -12, -24

ProFX10v3+ and ProFX12v3+ - Two columns of 12 segments each: OL, +15, +10, +6, +3, 0 (0 dBu), -2, -4, -7, -10, -20, -30

USB

Format:	USB 2.0
I/O:	1 Stereo Input, 2 Stereo Outputs
A/D/A:	24-bit, 44.1 kHz, 48 kHz, 96 kHz, 192 kHz

Phantom Power

48 VDC to all Mic channels simultaneously

Power Requirements

Power Connector

ProFX6v3+ • ProFX10v3+: 12V  2A Class I Hard-Wired Wall Mount Adapter [Output]
 100VAC-240VAC, 50-60 Hz, 0.8A [Input]
 ProFX12v3+: 3-Pin IEC Line Cord, 100VAC-240VAC, 50-60 Hz

Operating Temperature: 0-40° C // 32-104° F

Dimensions

Size (H x W x D): 2.9 x 7.5 x 8.4 in // 74 x 191 x 213 mm [ProFX6v3+]
 3.3 x 10.7 x 11.9 in // 84 x 272 x 302 mm [ProFX10v3+]
 4.0 x 13.0 x 14.8 in // 102 x 330 x 376 mm [ProFX12v3+]

Weight: 2.6 lb // 1.2 kg [ProFX6v3+]
 4.9 lb // 2.2 kg [ProFX10v3+]
 7.9 lb // 3.6 kg [ProFX12v3+]

Options

ProFX6v3+ Carry Bag: P/N 2051719
 ProFX10v3+ Carry Bag: P/N 2051720
 ProFX10v3+ Dust Cover: P/N 2051726
 ProFX12v3+ Carry Bag: P/N 2051721
 ProFX12v3+ Dust Cover: P/N 2051727
 ProFX12v3+ Rack Ear Kit: P/N 2051623

About

Part Number, Rev and Date: SW1430, Rev A, September 2023

LOUD Audio, LLC. is always striving to improve our products by incorporating new and improved materials, components, and manufacturing methods. Therefore, we reserve the right to change these specifications at any time without notice. The "Running Man" is a registered trademark of LOUD Audio, LLC. All other brand names mentioned are trademarks or registered trademarks of their respective holders, and are hereby acknowledged.

Please check our website for any updates to this Owner's Manual: www.mackie.com.
 ©2023 LOUD Audio, LLC. All right All right All rights reserved.

ProFX6v3+ Dimensions

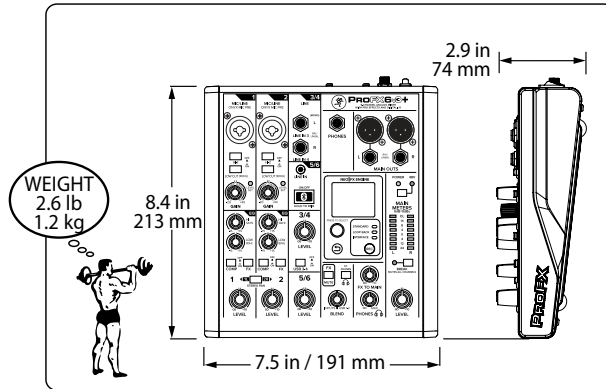

ProFX10v3+ Dimensions

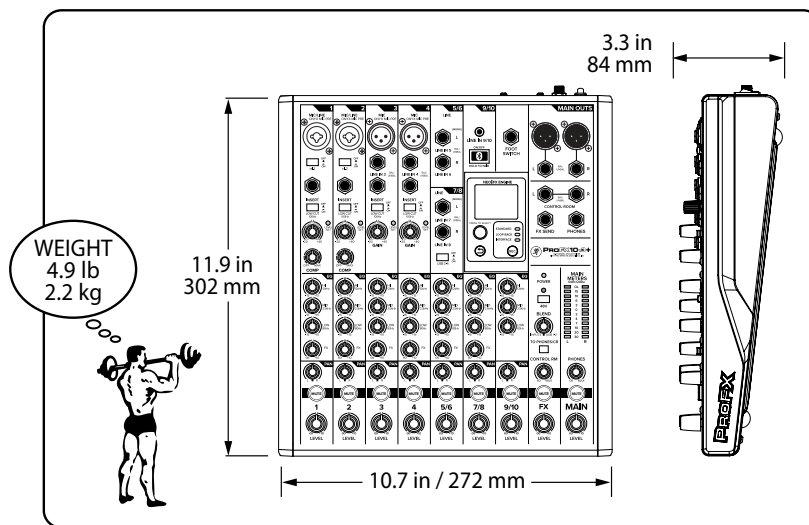

ProFX12v3+ Dimensions

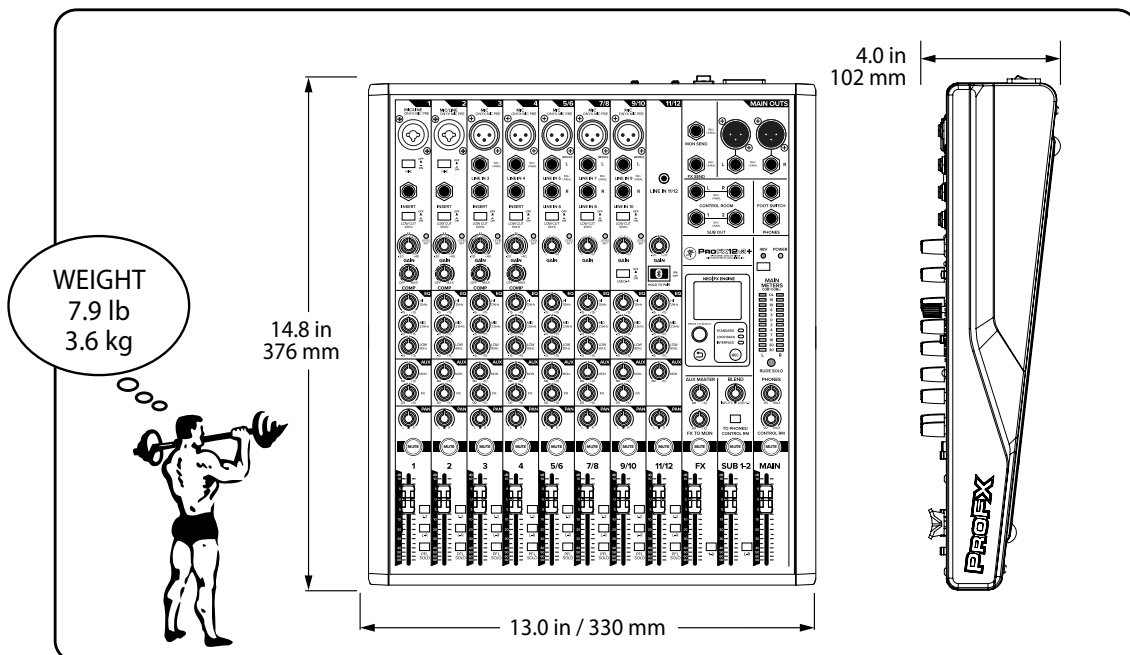

ProFX6v3+ Track Sheet

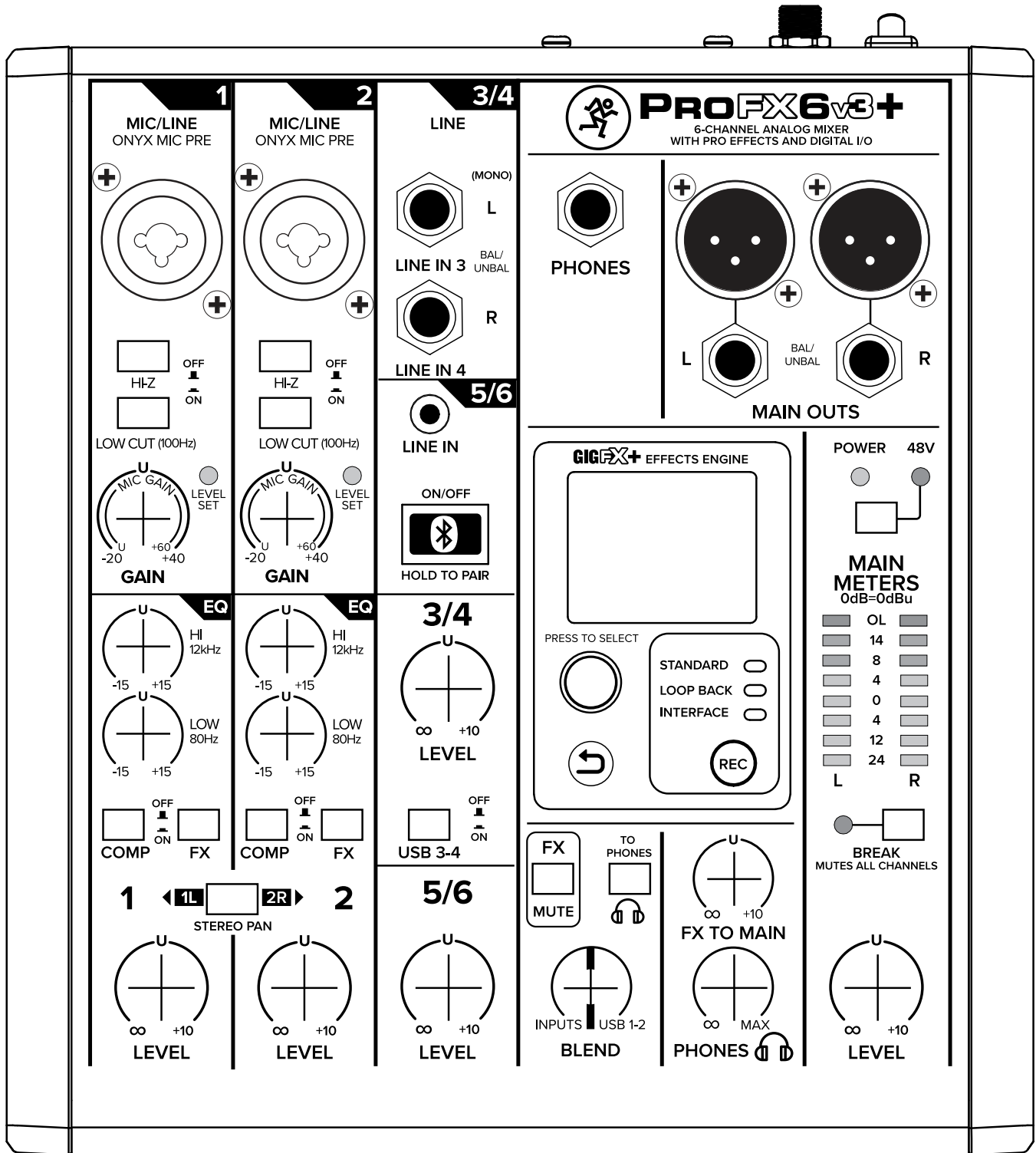

ProFX10v3+ Track Sheet

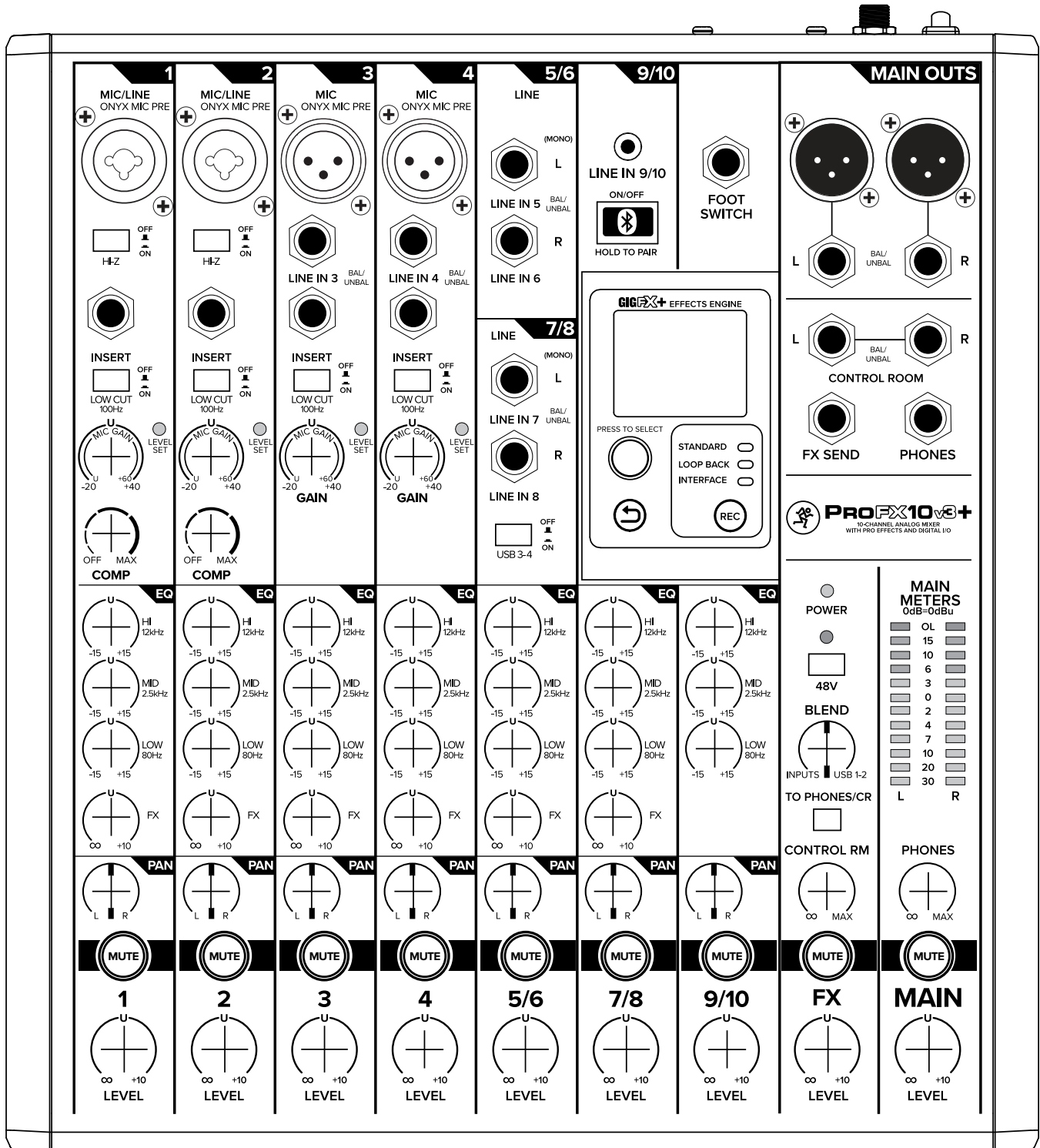

ProFX12v3+ Track Sheet

The diagram illustrates the ProFX12v3+ Track Sheet, a multi-channel analog mixer. It features 12 input channels, each with a MIC/LINE selector, HI-Z switch, INSERT point, LOW CUT filter (100Hz), GAIN knob, COMP (compression) knob, EQ (equalization) with HI (12kHz), MID (2.5kHz), and LOW (80Hz) frequency sliders, AUX (auxiliary) knob, PAN (panning) knob, and MUTE button. Channels 1-12 are labeled with their respective channel numbers. The output section includes MAIN SEND, FX SEND, CONTROL ROOM (with 1-2 selector), SUB OUT, MAIN METERS (0dB to 0dBu), and various monitoring options like PHONES, FOOT SWITCH, and MAIN METERS. The mixer also features a GIGAPACK EFFECTS ENGINE with a digital display and buttons for STANDARD, LOOP BACK, INTERFACE, and REC. Other features include a 48V POWER switch, a BLEND knob, and a TO PHONES/CONTROL RM switch.

Appendix C: USB 3/4 Return Setup

Introduction

ProFXv3+ mixers allow you to send audio from the computer into either the USB 1/2 Blend Mix or the 3/4 Main Mix. USB 1/2 is most useful for overdubbing when recording, while 3/4 is typically used for backing tracks, streaming or game audio.

When connected to a computer, the ProFXv3+ defaults to USB 1/2. To change this to USB 3/4, the computer's settings will need to be changed. Here we cover basic Windows and Mac setup applications that use the system's audio settings.

**NOTE**

Some DAWs and other streaming applications have their own settings that may override system settings. If so, please review their documentation on how to make changes to the DAW / app.

Windows

1. Download the USB driver from the Mackie website.
2. Follow the installation instructions to install the driver.
3. Right-click on the speaker icon located on the task bar.
4. Select Sound Settings.
5. Under "Choose Your Output Device", select ProFXv3+ 3-4 from the dropdown menu.
6. On the mixer, be sure the USB 3/4 button is engaged (down) on the second-to-last channel.
7. On the ProFX12v3+ mixer, engage the LR routing button located next to the fader. This will send the signal to the main mix.
8. Turn up the channel fader to unity, then slowly turn up the main mix fader.

You will know this worked if the main meters illuminate and you hear PC audio through the device connected to the main outputs.

Mac

A driver download is not necessary on a Mac. However, some parameters will still need to be changed within macOS.

1. Open the Audio MIDI Setup app using the Spotlight search (Command + Spacebar).
2. Right-click on the device and select the ProFXv3+ mixer in "Use This Device For Sound Input", as well as "Use This Device For Sound Output".
3. Select the 'Configure Speakers' button and be sure it is set to 'Stereo'.
4. Change the Left and Right options to Analog 3 and 4, then tap 'Apply'.
5. On the mixer, be sure the USB 3/4 button is engaged (down) on the second-to-last channel.
6. On the ProFX12v3+ mixer, engage the LR routing button located next to the fader. This will send the signal to the main mix.
7. Turn up the channel fader to unity, then slowly turn up the main mix fader.

You will know this worked if the main meters illuminate and you hear PC audio through the device connected to the main outputs.

Warranty Statement

Please keep your sales receipt in a safe place.

This Limited Product Warranty ("Product Warranty") is provided by LOUD Audio, LLC. ("LOUD") and is applicable to products purchased in the United States or Canada through a LOUD-authorized reseller or dealer. The Product Warranty will not extend to anyone other than the original purchaser of the product (hereinafter, "Customer," "you" or "your").

For products purchased outside the U.S. or Canada, please visit www.mackie.com/warranty to find contact information for your local distributor, and information on any warranty coverage provided by the distributor in your local market.

LOUD warrants to Customer that the product will be free from defects in materials and workmanship under normal use during the Warranty Period. If the product fails to conform to the warranty then LOUD or its authorized service representative will at its option, either repair or replace any such nonconforming product, provided that Customer gives notice of the noncompliance within the Warranty Period to the Company at: www.mackie.com/support or by calling LOUD technical support at 1.800.898.3211 (toll-free in the U.S. and Canada) during normal business hours Pacific Time, excluding weekends or LOUD holidays. Please retain the original dated sales receipt as evidence of the date of purchase. You will need it to obtain any warranty service.

For full terms and conditions, as well as the specific duration of the Warranty for this product, please visit www.mackie.com/warranty.

The Product Warranty, together with your invoice or receipt, and the terms and conditions located at www.mackie.com/warranty constitutes the entire agreement, and supersedes any and all prior agreements between LOUD and Customer related to the subject matter hereof. No amendment, modification or waiver of any of the provisions of this Product Warranty will be valid unless set forth in a written instrument signed by the party to be bound thereby.



19820 North Creek Parkway #201, Bothell, WA 98011 • USA
Phone: 425.487.4333 • Toll-free: 800.898.3211
Fax: 425.487.4337 • www.mackie.com

 **MACKIE.**
SOUND LIKE YOU MEAN IT[®]