

KORG

MPS-10

DRUM, PERCUSSION & SAMPLER PAD

Owner's Manual

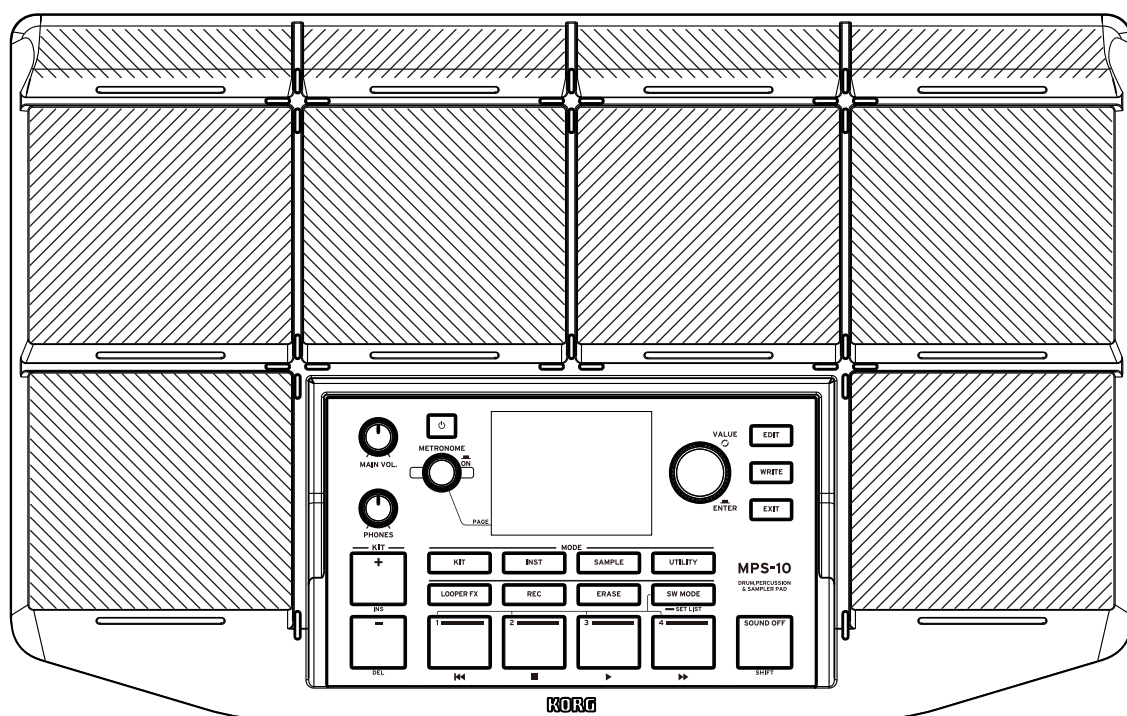

Table of contents

Introduction	5
Main features	5
Rich expressiveness and a wide variety of presets	5
Continuous control pads	5
Four-track looper	5
Sampler	5
SET LIST function	5
Connecting to a computer	5
USB flash drive support	5
Part names and functions	6
Front panel	6
1. Pads	6
2. Continuous control pads (CC pads)	6
3. Control panel	6
Control panel	7
1. (Power) button	7
2. Display	7
3. MAIN VOL. knob	7
4. PHONES knob	7
5. KIT+ (INS), KIT- (DEL) buttons	7
6. METRONOME knob, button	7
7. VALUE knob, ENTER button	7
8. MODE buttons	7
9. LOOPER FX button	8
10. REC button	8
11. ERASE button	8
12. SW MODE button	8
13. Track 1-4 buttons	8
14. EDIT button	8
15. WRITE button	8
16. EXIT button	8
17. SOUND OFF (SHIFT) button	8
Rear panel	9
1. PHONES OUT jack	9
2. MAIN OUT R, MAIN OUT L (MONO) jacks	9
3. SUB OUT 1, SUB OUT 2 jacks	9
4. LINE IN L/R jack	9
5. MIC IN jack	9
6. TRIGGER IN CH A/B, TRIGGER IN CH C/D jacks	9
7. FOOT SW 1, 2 jacks	9
8. EXPRESSION PEDAL jack	10
9. MIDI OUT connector	10
10. TO MEMORY DRIVE port	10
11. TO PC port	10
12. DC 9V jack	10
Bottom side	10
Mount adapter for attachment	10
Turning the power on/off	11
Connecting the AC adapter	11
Turning the power on	11
Turning the power off	12
Auto power-off function	12
Playing the MPS-10	14
Performing with the pads	14
Pad LED color	14
CC pads	14
Changing the KITs	15
Viewing the top page	15
Using the button to select a KIT	15
Using the knob to select a KIT	15

What you can do on the top page	16
LOOPER mode	16
CC PAD mode	17
SET LIST mode	17
Using the metronome	18
Editing the KITS	20
How the sound generator is structured	20
Displaying and editing the KIT EDIT menu	21
Selecting INSTs to assign to pads	21
Copying the settings for the pads	22
Saving a KIT	23
Displaying and editing the INST edit menu	26
Creating a new INST	26
Saving an INST	28
Using the Looper function	31
Overdubbing with the looper	31
Details on looper operations	33
Track length in Sync mode	33
How the BPM and Beat settings work	33
Looper LCD screen display	33
Track button LEDs	34
Track modes	35
Recording play/stop	35
Length of track to record	35
Erasing recorded tracks	36
Looper effects	36
Sampler	37
Sampling	37
Displaying the SAMPLE edit menu and editing	38
Adjusting the start point and end point	40
Editing SAMPLE data	41
Saving a SAMPLE	43
Importing and exporting the SAMPLE data	44
Parameter guide	45
KIT EDIT menu	45
KIT EDIT / CC PAD	45
KIT EDIT / Foot SW	48
KIT EDIT / Exp Pedal	49
KIT EDIT / EQ	50
KIT EDIT / Insert FX	51
KIT EDIT / Main FX	52
PAD EDIT menu	54
INST edit menu	55
INST / Velocity	56
INST / Block Layout Edit	57
INST / Block Edit	58
LOOPER edit menu	59
LOOPER Setup / TRACK	61
LOOPER Setup / FX	61
SAMPLE edit menu	62
SAMPLE / RECORDER	62
SAMPLE / RECORDER Setup	63
SAMPLE / SAMPLE	64
SAMPLE / SAMPLE EDIT	64
SAMPLE EDIT / Normalize	64
SAMPLE EDIT / Truncate	65
SAMPLE EDIT / Pitch Edit	66
SAMPLE EDIT / Time Stretch	66

UTILITY menu	67
Setup	67
Setup / PAD Trigger	68
Setup / Audio In & Out	68
Setup / METRONOME	70
Setup / MIDI	70
Setup / Display	71
LOOPER	72
SET LIST	72
Using this unit with the set lists	72
Function Assign	73
Function Assign / PAD Function	73
Function Assign / Foot SW & Pedal	74
How to calibrate the pedal	75
Data Management	76
Import & Export	76
Import & Export / All User Data	76
Import & Export / SAMPLE	78
Import & Export / LOOPER Data	82
Import & Export / UTILITY Data	84
Rename	86
Move	87
Delete	90
System	92
USB Memory Format	92
Factory Reset	92
System Info	93
Saving the UTILITY settings	94
Appendix	95
Connecting to your computer	95
Windows	95
Macintosh	95
Folders on the USB flash drive	95
Troubleshooting	96
Power does not turn on	96
Power turns off abruptly	96
No sound is heard when the pads are played	96
Input/output volume is too low	96
The sound doesn't stop even when the SOUND OFF button is pressed	96
Can't hear the LINE IN (MIC IN) and USB Audio IN sound	96
The metronome can't be heard, even when turned on	96
Can't import SAMPLE files from USB flash drive	96
Can't export All User Data or SAMPLEs to the USB flash drive	97
BPM information is not included in the imported SAMPLE data	97
The Looper and SET LIST settings are erased when the power is turned off	97
LCD screen or LEDs are too dark or bright	97
Pedals are not operating as expected	97
When external pads are connected to the TRIGGER IN CH A/B or C/D jack and I play two pads at the same time, I only hear sound from one pad	97
Effects are not applied even when IFX is ON	97
Error messages	98
Block diagram	99
Main specifications	100

* All product names and company names are the trademarks or registered trademarks of their respective owners.

Introduction

Thank you for purchasing the Korg MPS-10 Drum, Percussion & Sampler Pad.

To help you get the most out of your purchase, please read this manual carefully.

Main features

Rich expressiveness and a wide variety of presets

The MPS-10 features a wide variety of presets to cover many different genres, whose sounds change in diverse ways depending on how you play them. This unit also includes a large selection of loop sounds, extending its usefulness beyond that of a simple percussion sound source.

You can switch between sounds without interruption, making the MPS-10 a formidable choice for live performance.

Continuous control pads

With continuous control pads (CC pads: the four pads at the top of the panel), you can control parameters such as the built-in effects in real time, according to where you strike the pads.

Four-track looper

The MPS-10 features a four-track looper that lets you record not only the sound from this unit, but also audio from external input as well.

As each track can be recorded and played back in sync, and this unit also features a built-in effects unit for the looper, you can play the MPS-10 like a DJ.

Sampler

With the sampler, you can sample both the sound from this unit and from an external input at the same time. You can play the sampled sounds right away on the pads of the MPS-10. You can also edit the data that you sampled on this unit.

SET LIST function

You can reorder the KITS in the order you like. You can register up to eight set lists.

Connecting to a computer

This unit can transmit and receive MIDI messages and USB audio signals to/from a computer that's connected via USB.

USB flash drive support

Use a USB flash drive to import sample data into this unit that was created on a different device, or to back up the settings of the MPS-10.

Part names and functions

Front panel

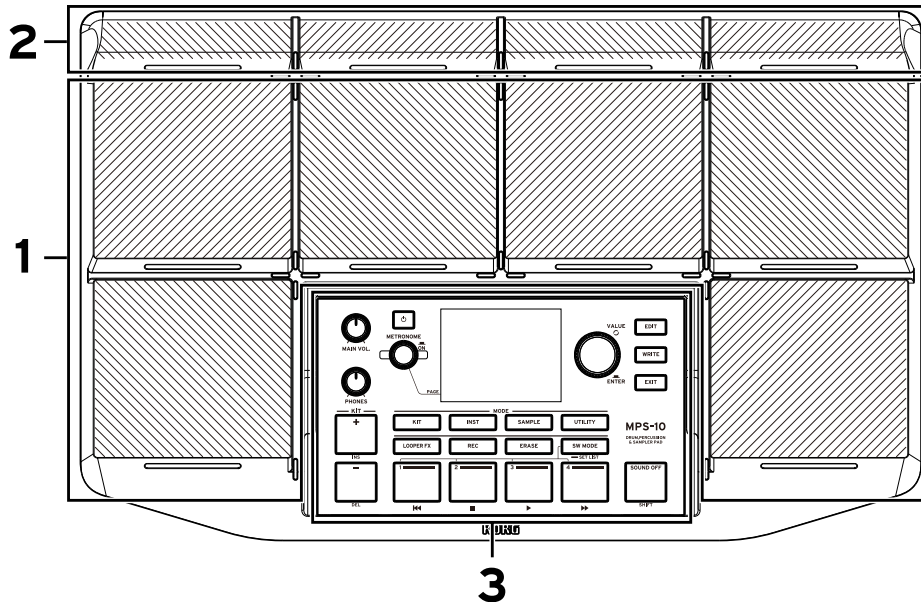

1. Pads

This unit features six pads that can be played. Strike the pads with your sticks to play.

2. Continuous control pads (CC pads)

There are four pads that let you control the built-in effects according to where you strike the pads, besides serving as regular pads.

3. Control panel

The control panel includes the buttons and knobs used for performing and editing, as well as a display that shows various information.

Control panel

Each button on the control panel has a built-in LED.

Only the buttons that are available in different situations (such as performing or editing) are lit up. Buttons that are unlit do not operate.

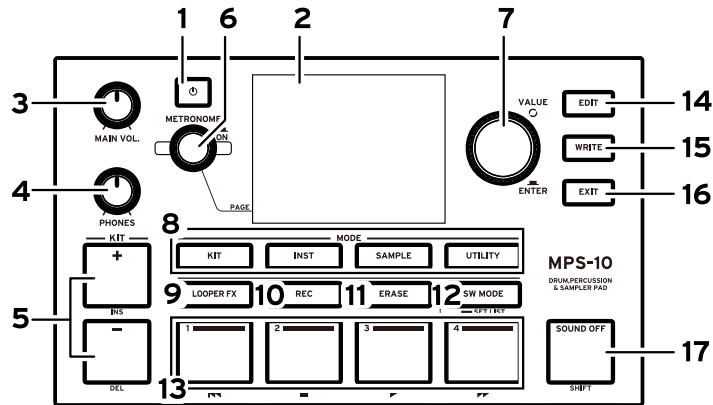

1. (Power) button

Turns the power on/off.

2. Display

Shows information about the KITS, looper, each of the parameters and so on.

3. MAIN VOL. knob

Adjusts the output volume for the MAIN OUT R, MAIN OUT L (MONO) and SUB OUT jacks.

4. PHONES knob

Adjusts the output volume for the PHONES jack.

5. KIT+ (INS), KIT- (DEL) buttons

Use these buttons to switch between KITS.

The buttons may work differently when you're editing.

6. METRONOME knob, button

Turn the knob to adjust the tempo of the built-in metronome. You can fine-tune the tempo setting in units of decimals by holding down the SHIFT button while turning the knob.

METRONOME ON/OFF button: Press this button to toggle the metronome on or off.

Tip: This is also used to switch between pages and so on while editing.

7. VALUE knob, ENTER button

Use these controls to switch between KITS and edit the parameters.

ENTER button: Pressing the VALUE knob gives the same result as pressing the ENTER button, and is used to confirm values, execute functions and access sub-menus.

8. MODE buttons

KIT: This button accesses KIT mode.

INST: This button accesses INST mode.

SAMPLE: This button accesses SAMPLE mode.

UTILITY: This button accesses UTILITY mode.

9. LOOPER FX button

This button turns the looper effect on/off.

10. REC button

Use this button to enter Record Standby mode or to stop recording. This also sets recording to standby when using the Sampler function.

11. ERASE button

Use this button to erase data from tracks recorded in the looper. This cancels recording when you're recording with the looper.

12. SW MODE button

Use this button when you're on the top page of KIT mode to switch between functions on tracks 1-4.

13. Track 1-4 buttons

These buttons function differently, depending on the SW MODE and edit state.

14. EDIT button

Shows the parameter edit menu for each mode, and opens the sub-windows for specific pages.

15. WRITE button

Used for saving the user settings.

16. EXIT button

Used to move up in the parameter edit menu hierarchy and to cancel the parameter setting, save operation and so on.

17. SOUND OFF (SHIFT) button

When you press and quickly release this button, all sounds currently playing are stopped.

When you long-press this button, the pad LEDs for sounds playing from another KIT light up blue, and you can strike those pads to individually stop their sounds.

Rear panel

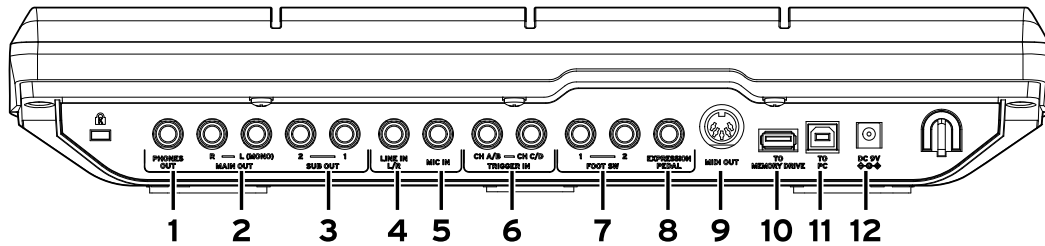

1. PHONES OUT jack

Connect your headphones here. You can monitor all of the audio through headphones, including MAIN OUT, SUB OUT and METRONOME. The headphone volume is controlled by the PHONES knob.

Tip: The volume may seem a little low if you are listening with headphones of 80 Ω impedance or more.

2. MAIN OUT R, MAIN OUT L (MONO) jacks

These are the main audio output jacks. Connect the input jacks of your powered monitor speakers, mixer or similar equipment to the MAIN OUT L (MONO), R jacks of this unit.



Turn off the power of your audio equipment before you connect anything. If you connect your gear while the power is on, you risk damaging your equipment or speakers.

Note: Audio signals that are set to output from SUB OUT are not outputted from the MAIN OUT jacks.

3. SUB OUT 1, SUB OUT 2 jacks

These are the sub audio output jacks. Only audio signals that are set to output from SUB OUT are outputted from these jacks.

4. LINE IN L/R jack

Use this jack to input external audio signals in stereo. The inputted signal is mixed with the audio from the internal sound generator and then output. You can also use this jack as an input source for the input audio used by the sampler and looper.

5. MIC IN jack

This is a jack with a built-in mic amp for directly connecting a mic. You can select either balanced or unbalanced input in the settings.



You can't use mics that require power, such as condenser mics.



You can't use the LINE IN L/R jack and the MIC IN jack simultaneously.

6. TRIGGER IN CH A/B, TRIGGER IN CH C/D jacks

Connect commercially available drum pads or similar accessories to these jacks.

As these are stereo (TRS) jacks, you can use a stereo splitter cable or the like to separate the signals and connect two drum pads.

7. FOOT SW 1, 2 jacks

Connect a Korg PS-1 or other foot switch here. You can assign functions to the pedal, such as looper start/stop.

8. EXPRESSION PEDAL jack

Connect a Korg XVP-20, EXP-2 expression pedal or similar pedal here. You can assign functions to the pedal, such as looper volume adjustment.

Note: If you're using the pedal for the first time, calibrate the pedal. (→ p. 75, "How to calibrate the pedal")

9. MIDI OUT connector

Use this to connect to an external sound generator or other MIDI device. When you use a cable to connect the MIDI OUT connector of the MPS-10 to the MIDI IN connector of an external MIDI device, you can use the pads of the MPS-10 (or the pads connected to the MPS-10) to play the external MIDI device.

10. TO MEMORY DRIVE port

Connect a commercially available USB flash drive here. WAV files and setting data can be read and written to and from the flash drive.

Make sure to format the USB flash drive on this unit before use.

Note: A USB flash drive with up to 2 TB capacity can be used. Some USB flash drives may not work with the MPS-10.

Note: Some USB flash drives may heat up when accessed at high speeds.

11. TO PC port

To exchange MIDI message data between the MPS-10 and your computer, connect the TO PC port of this unit to your computer with a commercially available USB 2.0 cable. This port can also send and receive USB audio signals.

12. DC 9V jack

Connect the included AC adapter here.

Bottom side

Mount adapter for attachment

By attaching a commercially available mount adapter, you can mount the MPS-10 onto a cymbal stand or the like.

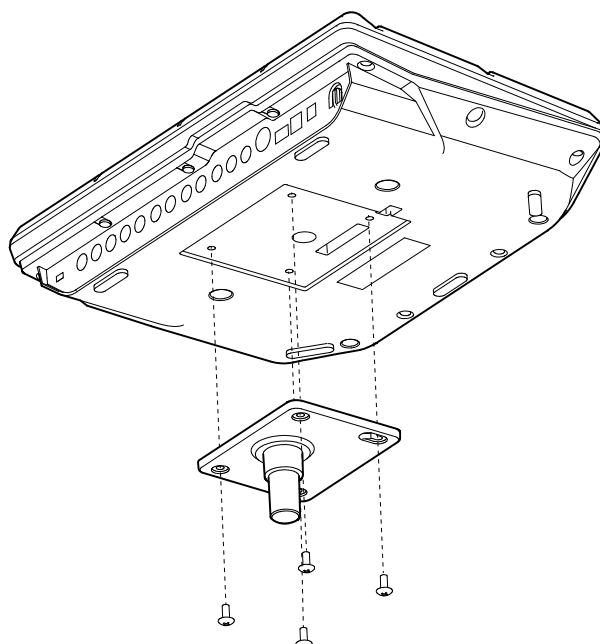

Turning the power on/off

Connecting the AC adapter

- 1 Connect the DC plug of the included AC adapter to the DC 9V jack on the rear panel.
- 2 After connecting the DC plug, hook the AC adapter cord onto the cord hook.

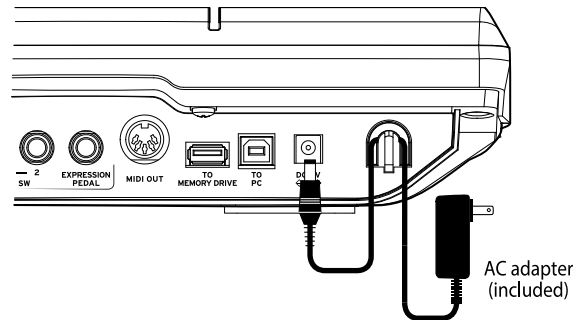

- ⚠ Make sure to use the included AC adapter. Using a different AC adapter may cause a malfunction or other issues.
- ⚠ Do not use excessive force when pulling the cord off the hook. Doing so may cause damage to the plug.

- 3 Connect the AC adapter to an AC outlet.

- ⚠ Be sure to use an AC outlet of the correct voltage for your AC adapter.

Turning the power on

- 1 Turn the MAIN VOL. and PHONES knobs on this unit all the way down (counterclockwise) to minimize the volume.
Make sure that the volume on any external devices that are connected (such as mixers or powered monitor speakers) is turned down and that the power is turned off.
- 2 Press the **⏻** (Power) button on the MPS-10.
After the opening screen is shown on the display, the KIT name is shown.
This page is called the top page. (→ p. 15, "Viewing the top page")

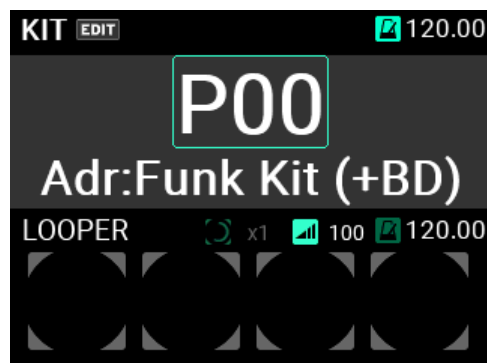

Tip: The KIT last selected before the power was turned off is shown.

- 3 Turn on the external output devices connected to this unit.
Turn on the power of the external output devices that are connected to the MPS-10's output jacks (MAIN OUT L (MONO), R), such as powered monitor speakers or mixers.
- 4 Adjust the volume to the optimal level.
Adjust the MAIN VOL. knob on this unit, and set the volume on your external output devices to a suitable level.

Turning the power off

- 1 Turn the volume all the way down on any external output devices that are connected.
Lower the volume on the external output devices connected to this instrument, and then turn off the power of these devices.
Turn the MAIN VOL. and PHONES knobs on this unit all the way down (counterclockwise) to minimize the volume.
- 2 Keep holding the  (Power) button on the MPS-10 down until the message "POWER OFF" is shown in the display.
Once the display goes dark, the power turns off.

 Do not unplug the AC adapter before the display goes dark. Doing so may cause a malfunction.

When you turn off the power, a popup message is shown that asks if you want to save or discard your settings if you haven't saved your edits yet.



To turn off the power without saving, press the ENTER button. To save the settings, press the EXIT button to cancel the power-off action, save your settings, and press the power button again to turn off the power.

Auto power-off function

The MPS-10 has an auto power-off function that automatically turns off the power if the pads have not been played or if the front panel buttons and controls have not been used for a certain length of time.

You can change the time it takes for the unit to turn off automatically, or disable the auto power-off feature entirely.

- 1 Press the UTILITY button to enter UTILITY mode.

If you're accessing a page for which the UTILITY button is not lit, press the EXIT button repeatedly until you get to a page where the UTILITY button lights up, and then press the UTILITY button.

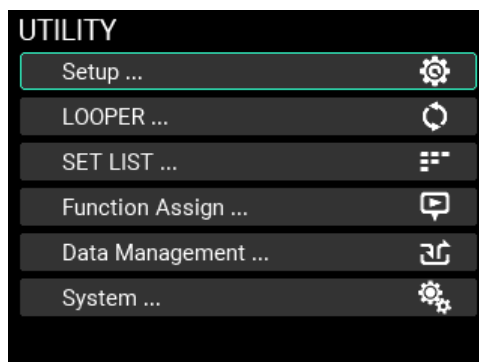

2 Enter the Setup page.

From the top page, select “Setup” and press the ENTER button to switch to the Setup page.

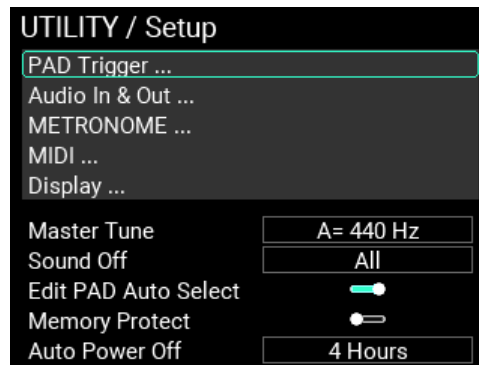

Select “Auto Power Off” here, and press the ENTER button. Use the VALUE knob to change the setting.

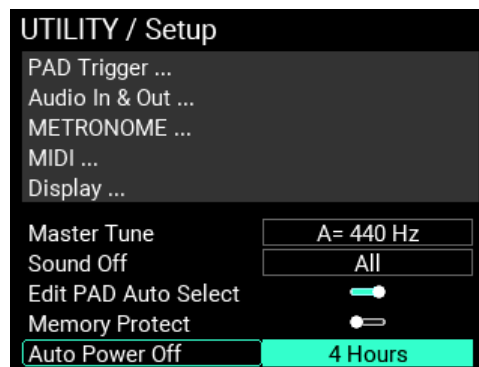

Disable: Disables the auto power-off function.

30 Minutes: Automatically turns the power off if you have not operated the unit for 30 minutes.

4 Hours: Automatically turns the power off if you have not operated the unit for four hours.

Tip: This is set to “4 Hours” by factory default.

Press the ENTER button to confirm the setting, or press the EXIT button to cancel.

3 Save the modified setting.

To save the new setting, press the WRITE button.

When you press the WRITE button, a pop-up window appears.

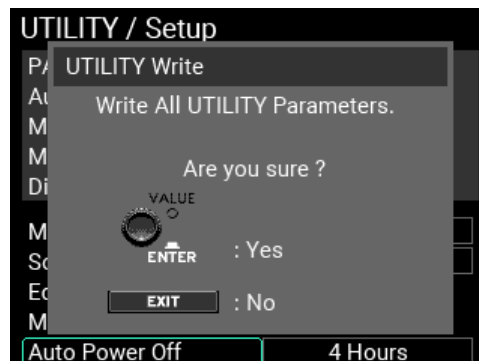

Press the ENTER button to save the auto power-off function setting.

If you decide to cancel saving, press the EXIT button.

Tip: The WRITE button can be used from any page in UTILITY mode, provided that a sub-window such as a warning is not open.

Playing the MPS-10

Now that you've made all the connections and the power turns on normally, get your drumsticks ready and play the pads.

Performing with the pads

When you strike a pad with your drumsticks, for example, sound plays from the headphones connected to the PHONES jack on this unit, and from the powered monitor speakers or other audio equipment connected to the MAIN OUT L (MONO), R jacks.

Use the PHONES knob to adjust the volume of sound coming from the headphones jack, and use the MAIN VOL. knob to adjust the volume of the MAIN OUT L (MONO), R jacks.

On some KITS, the sound can change or the effects may sound different depending on how hard you strike the pads.

Pad LED color

The pads make sounds when you strike them if the LED in front of each pad is lit up in blue (cyan) or in red (magenta). The LEDs light up more brightly when the pads are making sounds.

The LED colors differ depending on the sound that's assigned to the pad, as follows:

Red (magenta): one-shot sound; blue (cyan): repeating sound; green (viridian): no sound (no assignment)

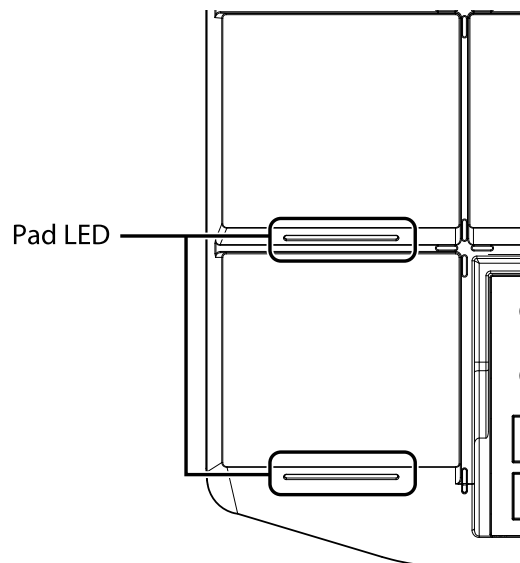

CC pads

There are four thinner pads located at the top of the panel. These pads sense where they are struck, and are called CC pads. You can use the position sensing feature of these CC pads to control the effect parameters and so on.

For instance, you can play these pads continuously from left to right to achieve the effect of a filter opening, among other effects.

A bar is shown for the current position of the CC pad on the top page of display KIT mode, for KITS whose CC pad is enabled (if the SW MODE is LOOPER or SET LIST).

By switching the SW MODE to CC PAD, you can use the track 1-4 buttons to switch the CC pad function on/off.

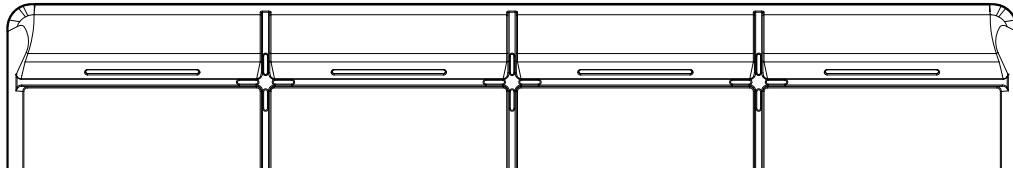

Changing the KITS

A “KIT” consists of 10 pad sounds in the MPS-10, four pad sounds that can be connected externally, and the sound that can be played when you press a connected expression pedal, for a total of 15 different sounds.

By selecting this KIT, you can switch between the sounds assigned to each pad and play them.

Viewing the top page

The page that’s shown on the display when you turn on the power is called the “top page”.

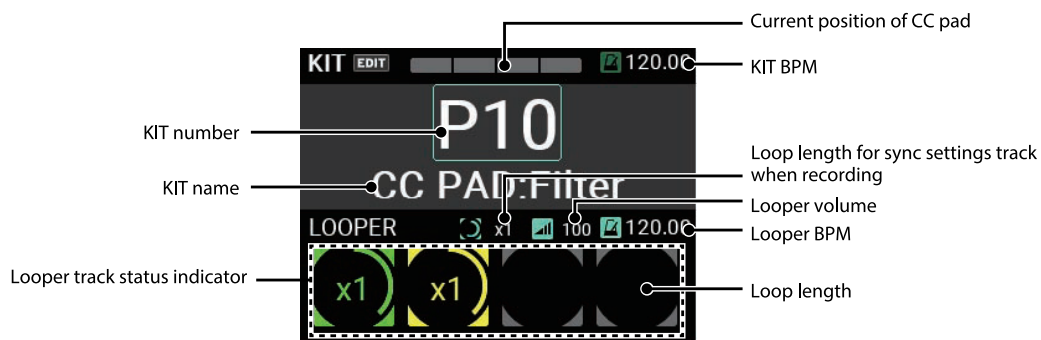

The KIT number and name, CC pad state, looper status and so on are shown on the top page. You can use the KIT + and - buttons as well as the VALUE knob to switch between KITS. You can also use the pads or a footswitch to change the KITS.

Using the button to select a KIT

Press the KIT + and - buttons to switch between the KITS before and after the current KIT.

When you select KITS in order, this lets you quickly switch between them when you’re performing.

Using the knob to select a KIT

You can also use the VALUE knob to select a KIT number, which lets you freely switch between KITS.

- 1 Turn the VALUE knob to move the cursor to a KIT number.

- 2 Press the ENTER button (VALUE knob) to highlight the KIT number.



- 3 Turn the VALUE knob to select the KIT number.

When you switch to a different KIT, the KIT number and name blink. This means that you haven't yet switched to the new KIT.

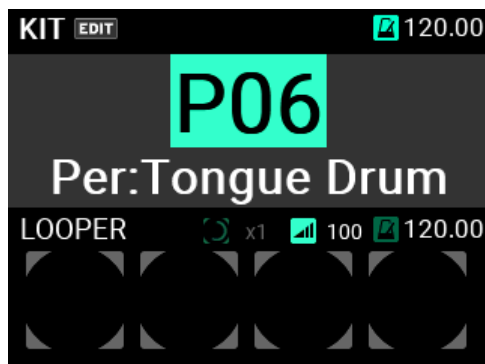

- 4 Once you press the ENTER button (VALUE knob), the KIT number you selected is confirmed.

Tip: There are 200 KITS included on the MPS-10. The first 100 KITS are preset KITS, and the last 100 KITS are user KITS.

What you can do on the top page

On the top page, aside from selecting KITS you can select looper tracks, configure the functions for the CC pads, select the set lists and so on.

By pressing the SW MODE button, you can change the functions called up by the TRACK 1-4 buttons (a total of three types).

Here's an explanation of the operations you can access when the top page is shown.

LOOPER mode

The MPS-10 features a four-track looper. (→ p. 31, "Using the Looper function")

When in Looper mode, the TRACK 1-4 buttons operate as looper tracks.

Large TRACK buttons are available on the bottom part of the control panel, giving you smooth access to the tracks while you're playing.

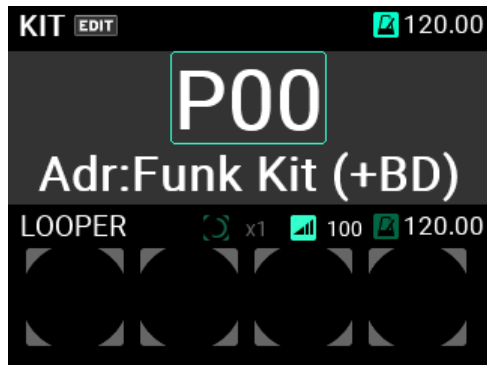

With the looper, you can record the same sound that's output from the MAIN OUT L (MONO), R jacks (what you play on the pads as well as the AUX IN/MIC IN input audio) for endless overdubbing.

You can freely switch between KITS while the looper is playing, which lets you overdub sounds from different KITS or play different KITS while the looper is playing back.

Note: Note that the metronome can't be recorded.

Note: When you press the SW MODE button while the looper is operating, the rec, overdub and erase rec operations stop, and the unit enters Playback mode.

CC PAD mode

You can use the CC pads to detect where you strike the pads and then use that data to control the functions that you set.

The four functions that can be controlled by the CC pads include TRANSPOSE, NOTE DELAY, MFX and FILTER.

In CC PAD mode, you can use the TRACK 1-4 buttons to temporarily switch these functions on/off.



Refer to "KIT EDIT menu" (→ p.45) in this manual for the detailed settings.

SET LIST mode

When SW MODE button is lit, long-press the SW MODE button to turn the SET LIST function on.

You can use the SET LIST function to set the order in which the KITS are recalled as you like, without the need to actually reorder the KITS.

While the SET LIST function is on, SET LIST MODE is added to SW MODE, and pressing the SW MODE button toggles between LOOPER, CC PAD and SET LIST.



In SET LIST mode, use the TRACK 1-4 buttons to switch between KITS.

The KIT numbers registered to the set list are shown in groups of four in the bottom of the screen.

Switch to a different KIT by pressing one of the TRACK 1-4 buttons that's lit green.

You can also use the KIT +/- buttons and the VALUE knob to switch the KITS to show list numbers in a set list.

The numbers below the KIT numbers show the list numbers within the set list.

Also, the KIT numbers that are dimly shown to the left and right show the list numbers before and after the four KITS that are currently shown.

See "SET LIST" on page 72 for how to edit the set list.

Note: Long-press the SW MODE button while in SET LIST mode to exit SET LIST mode.

Using the metronome

The MPS-10 features a metronome, which acts as a guide to help you keep the tempo.

- 1** The metronome starts and stops with each press of the METRONOME knob.
- 2** Turn the METRONOME knob to adjust the tempo.
- 3** You can set the time signature, metronome sound and volume in the METRONOME menu on the Setup page, accessible from the UTILITY button.

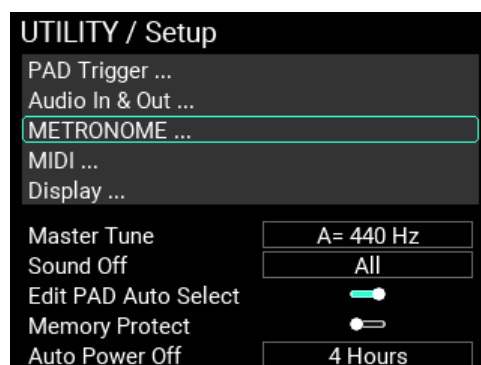

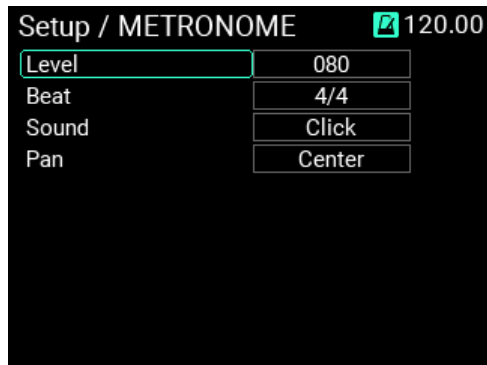

4 Save the modified setting.

To save the new setting, press the WRITE button.

An alert window is shown when you press the WRITE button. Press the ENTER button to save.

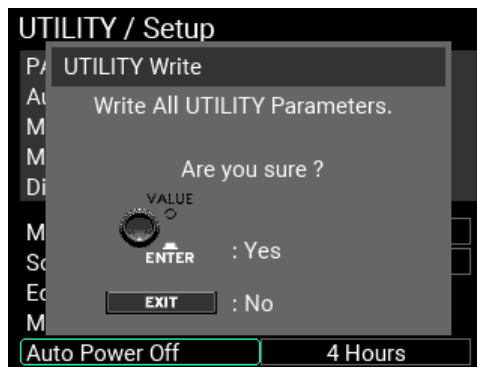

If you decide to cancel saving, press the EXIT button.

Editing the KITs

Aside from the sounds for the pads, each KIT stores the settings for each sound, as well as the EQ and effect settings.

The sounds assigned to each pad are called “INST” (instruments).

There are more than 2,000 INST available as presets on the MPS-10. You can enjoy a wide variation of sounds just by changing the INST assigned to each pad.

How the sound generator is structured

You can customize a KIT by freely assigning sounds to each pad on the MPS-10.

The sounds that are assigned to each pad of a KIT are called “INST” (instruments). One INST can be assigned to each pad.

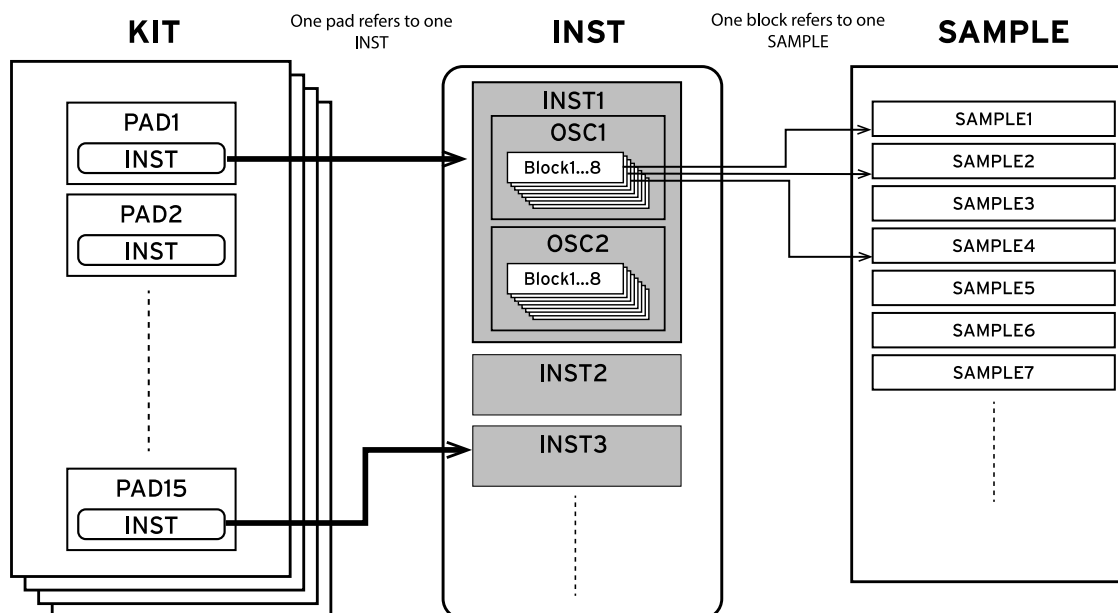

Each INST has up to two oscillators (OSC), and you can play two OSC at the same time for a single INST.

Further, each OSC contains up to eight “blocks”, and a SAMPLE is assigned to each block.

To summarize, you can play up to 16 SAMPLEs at once with each pad.

For the SAMPLEs, you can use the SAMPLE data that was recorded using the sampling functions of this unit, or import external audio files (WAV files in 44.1 kHz/48 kHz 16-bit format or AIFF files in 44.1 kHz/48 kHz 16-bit format) via a USB flash drive.

The KITs, INSTs and SAMPLEs are independent of each other. You can mix and match the INSTs you like to make a KIT, or combine the SAMPLEs you like to create an INST.

Displaying and editing the KIT EDIT menu

This explains how to switch between the INSTs that are assigned to each pad.

Selecting INSTs to assign to pads

- 1 Go to the top page in KIT mode.
If you're not in KIT mode, press the KIT button. If you're on a different page that's not in KIT mode, press the EXIT button repeatedly until you see the top page.
- 2 Once the screen switches to the top page in KIT mode, use the KIT + and - buttons to select the KIT you want to edit.
- 3 Once you've selected a KIT, press the EDIT button to show the KIT EDIT page.



- 4 Turn the METRONOME knob to show the PAD EDIT page.



- 5 When you press the ENTER button to select "PAD #", the pad number is highlighted. There are 15 pads included in the KIT, which are shown in the top right corner of the screen. The selected pad is shown with a light-blue border.

Tip: You can also strike a pad to change the pad number.

- 6 When you turn the VALUE knob to change the pad number and press the ENTER button, this confirms the new pad number, and the screen returns to parameter selection. At that time, all parameters aside from "PAD #" change to the pad contents that were set.

Note: If you press the EXIT button while you're changing the pad numbers, the edit is canceled and the screen returns to parameter selection.

Once the pad for which you want to switch INSTs is confirmed, use the VALUE knob to select “INST” and press the ENTER button. An INST selection screen appears like the one shown here.

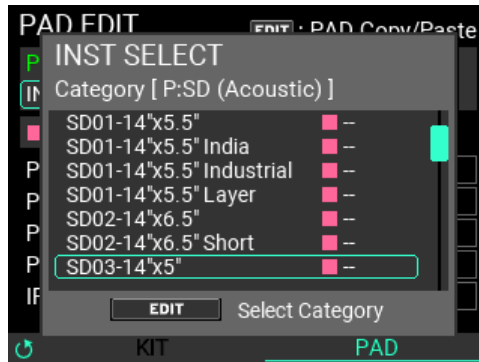

The category (Category Name), INST name, one-shot/repeat (square: magenta; circle: cyan) and BPM data are shown on the INST (instrument) selection page. Turn the VALUE knob to select an INST, and press the ENTER button. The INST is selected, and the display returns to the previous page.

Press the EXIT button to cancel and return to the previous page.

7 Now the INST that’s assigned to the pad has been changed. Strike the pad to confirm.

Switching between categories

The only INSTs listed on this page are those in the currently selected category.

Press the EDIT button to switch between categories.

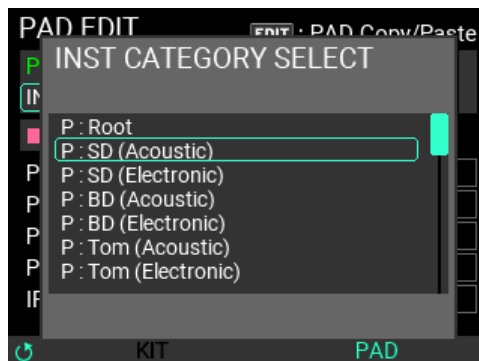

This shows the category selection sub-window. Turn the VALUE knob to select a new category, and press the ENTER button.

To close the sub-window without changing the category, press the EXIT button.

Once you change the category, the INST for the new category is shown.

Copying the settings for the pads

You can copy the settings from each pad to other pads, or to pads in other KITS.

When you press the EDIT button while in PAD EDIT, a pop-up menu appears where you can choose whether to copy or paste the selected pad.



To copy the pad's settings, use the VALUE knob to select "Copy from PAD #", and press the ENTER button.

Next, select the pad you want to copy in "PAD #" and press the EDIT button. In the pop-up menu that appears, use the VALUE knob to select "Paste to PAD #", and press the ENTER button.

Saving a KIT

If you've edited the settings of a KIT, you need to save it.

- 1 On the KIT EDIT screen, press the WRITE button. The KIT WRITE page appears

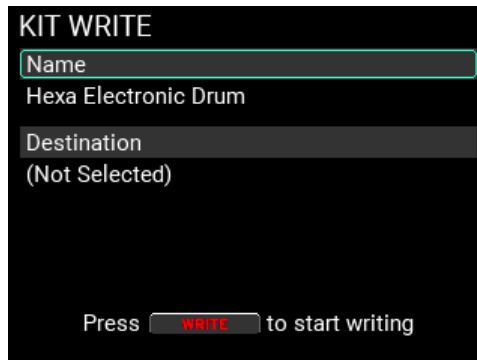

- 2 With "Name" selected, press the ENTER button to show the KIT name edit screen.

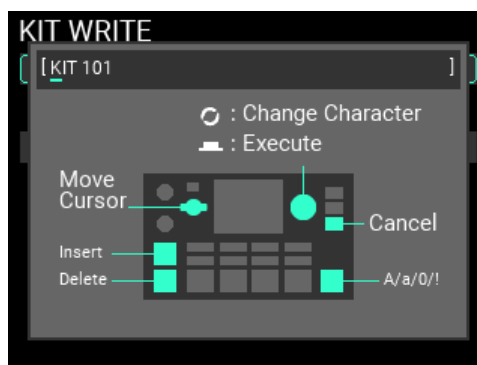

Turn the METRONOME knob to move the cursor, and use the VALUE knob to edit the characters.

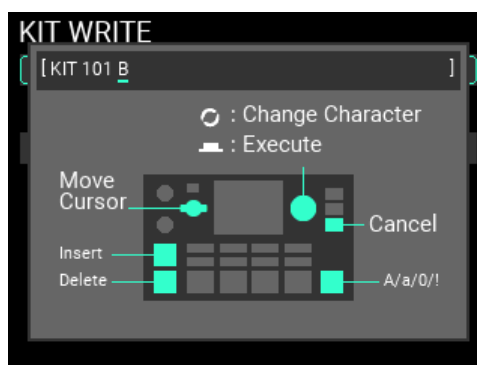

- 3 Once you've finished inputting the KIT name, press the ENTER button to return to parameter selection.

Tip: Press the EXIT button if you wish to cancel editing. The original name remains unchanged, and the unit returns to the previous page.

- With “Destination” selected, press the ENTER button to see the page on which you can specify where to save the KIT.

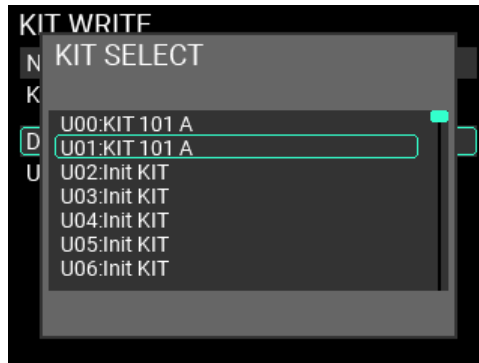

Press the ENTER button to confirm the selection to save the KIT, or press the EXIT button to cancel.

- Press the WRITE button again once you’ve confirmed the KIT name and the save destination. An alert window appears as shown here. To write the data, press the ENTER button. To cancel, press the EXIT button.

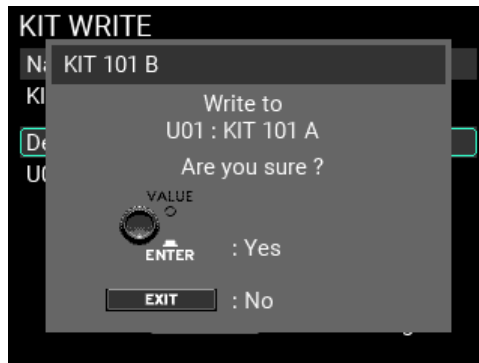

- If the write operation is successful, the KIT changes to the save destination KIT, and the screen switches to the top page in KIT mode.

Tip: If you press the EXIT button to cancel the write operation and close the window and then press the EXIT button again, you can return to the previous page before the write operation begins.

Using the Name dialog box (how to change the name)

With “Name” selected, press the ENTER button to show the screen where you can edit the name of the KIT and so on.

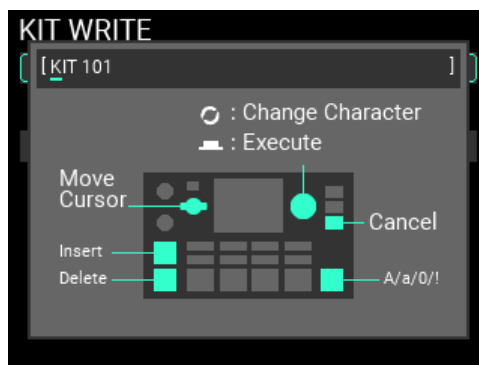

Turn the METRONOME knob to move the cursor, and use the VALUE knob to edit the characters.

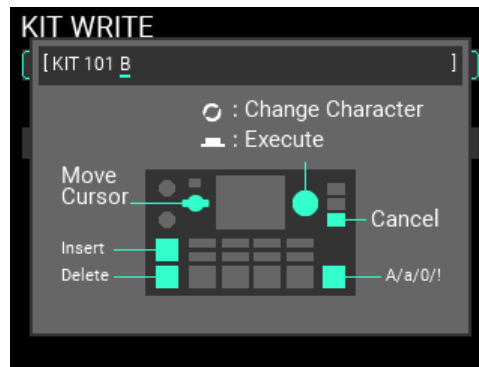

KIT + button: inserts a space at the cursor position

KIT - button: deletes one character at the cursor position

SOUND OFF button: toggles the character type between uppercase, lowercase, numbers and symbols

Press the ENTER button once you've finished inputting.

Press the EXIT button to cancel editing. The original name remains unchanged, and the unit returns to the previous page.

Displaying and editing the INST edit menu

The MPS-10 lets you combine multiple SAMPLEs to create new INST.

In this example, we explain how to use one SAMPLE to create a new INST.

Creating a new INST

- 1 Go to the top page in INST mode. If you're not in INST mode, press the INST button.

When you do this, the INST that's assigned to the last pad you selected (struck) becomes the pad to be edited.

Tip: You can also move the cursor to "PAD#" and change the pad number there.

Note: You can't switch between KITS on the INST page.

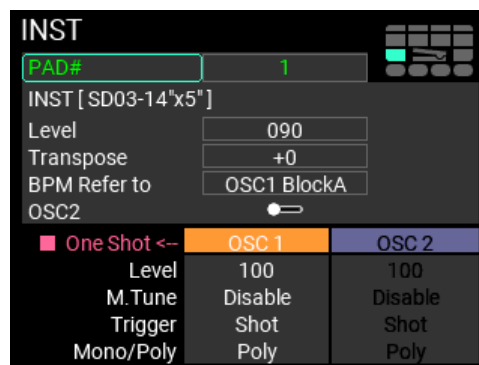

- 2 With the cursor positioned at "INST" (to create a new INST), press the ENTER button to show the "INST SELECT" screen.



When you press the EDIT button to select a category, select "P:Root" with the ENTER button.

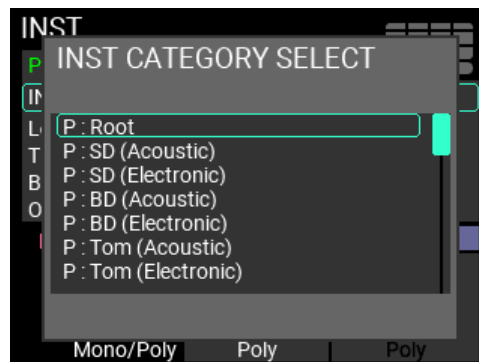

With the cursor positioned at “Template “One Shot””, press the ENTER button again to select it.

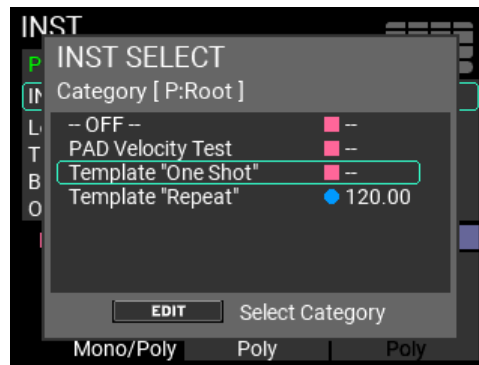

3 Press the EDIT button to access the INST EDIT page. The Velocity page is shown.

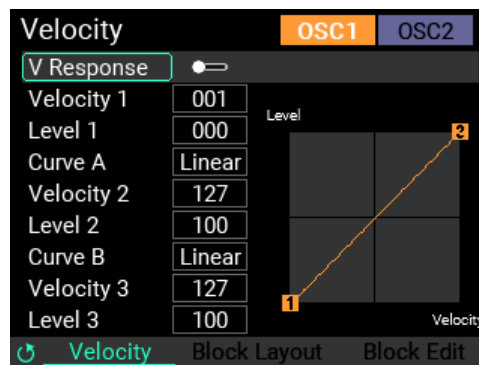

On this screen, move the cursor to “V Response” and press the ENTER button to disable “V Response”. With this setting, the volume does not change according to how hard you strike the pads.

4 Turn the METRONOME knob to show the Block Edit page.

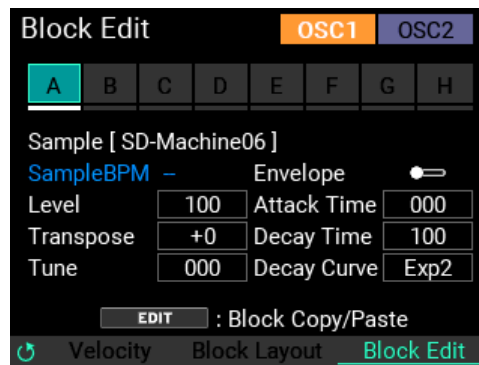

Turn the VALUE knob to move the cursor to “A” and press the ENTER button to select it.

5 With the cursor positioned at “SAMPLE”, press the ENTER button. The SAMPLE SELECT page like the one below is shown.

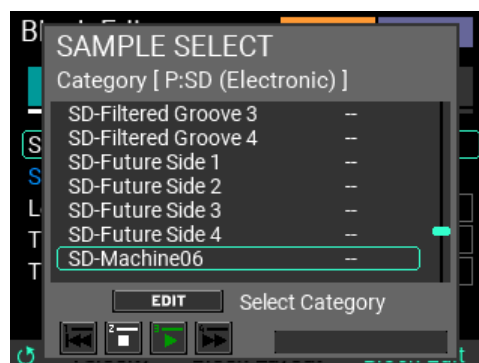

Only the SAMPLEs in the currently selected category are listed on this page.

To switch between categories, press the EDIT button on the SAMPLE SELECT page.

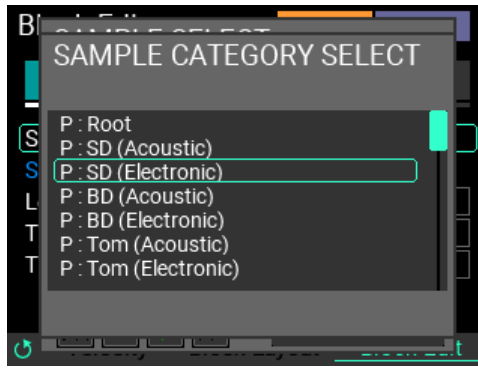

This shows the SAMPLE CATEGORY SELECT page as shown above. Turn the VALUE knob to select a new category, and press the ENTER button.

To close the sub-window without changing the category, press the EXIT button.

Once you change the category, the SAMPLEs for the new category are shown.

Move the cursor to the SAMPLE you want to select and press the ENTER button to finish selecting the SAMPLE file.

Tip: When the SAMPLE SELECT page is shown, the Track 1-4 buttons serve as transport keys. This lets you check the SAMPLE files. When you check the SAMPLE files, be careful that the headphone volume is not set too high, as the SAMPLE volume may be loud.

See “Editing SAMPLE data” on page 41 for more information on editing the SAMPLEs.

Saving an INST

To save the INST settings you’ve edited, you must write them to memory.

- 1 On the INST EDIT screen, press the WRITE button. The INST WRITE page appears as shown below.

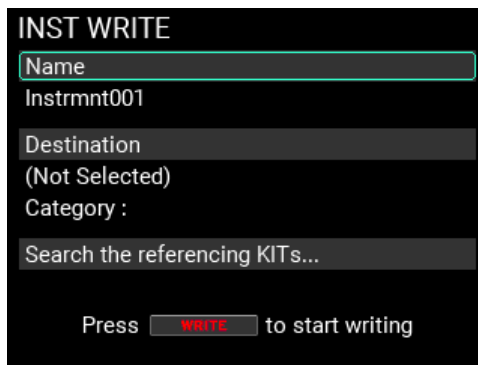

Note: You can write the data to memory from any page in INST Mode.

- 2 With “Name” selected, press the ENTER button to show the INST name edit screen. (→ p. 24, “Using the Name dialog box (how to change the name)”))



- With “Destination” selected, press the ENTER button to show the page on which you can specify where to save the INST.

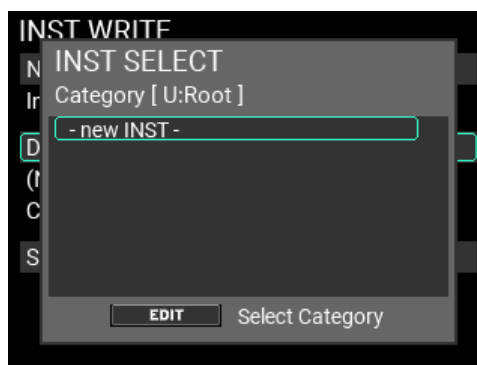
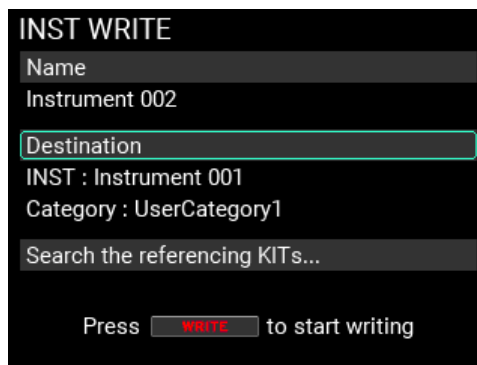

To select the category to save to, press the EDIT button. Select the category to which you want to save the INST you created, and press the ENTER button.

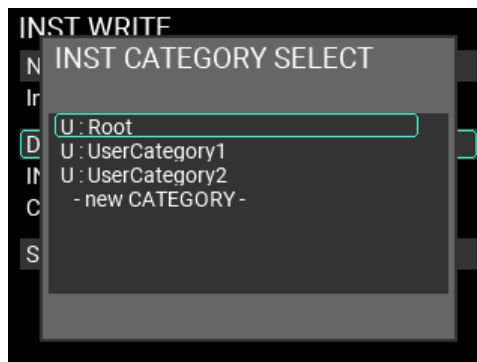

To create a new category, select “- new CATEGORY -” at the bottom row with the ENTER button. Input the new category name to create the new category. (→ p. 24, “Using the Name dialog box (how to change the name)”)

- This creates a new INST. Select “- new INST -” and press the ENTER button.

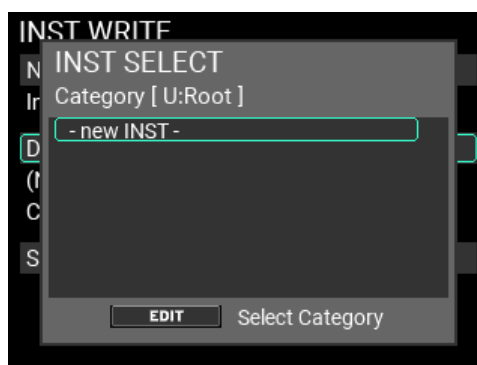

Note: You can also overwrite an existing INST, but you can’t recover an existing INST once you overwrite it.

- 5 On the INST WRITE screen, move the cursor to “Search the referencing KITS...” and press the ENTER button to check which KIT or KITS are using the INST that’s referenced by “Destination”.

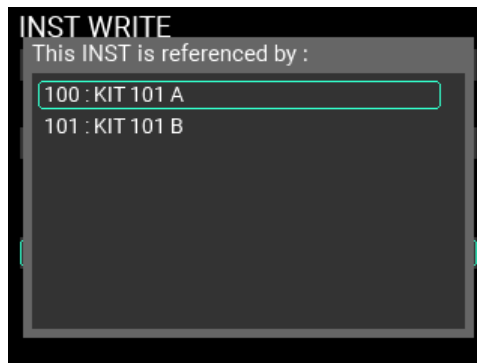

Tip: If many KITS are referencing that INST, use the VALUE knob to scroll through the list.

- 6 Press the WRITE button again once you’ve confirmed the INST name to save and the save destination. An alert window appears as shown here. To write the data, press the ENTER button. To cancel, press the EXIT button.

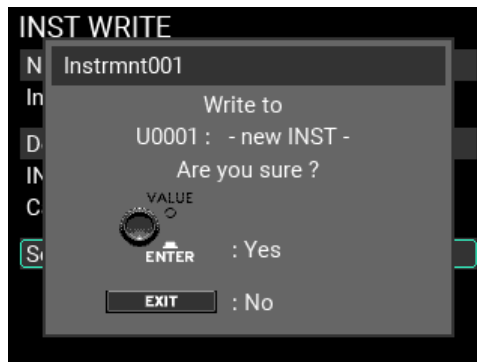

- 7 If the write operation is successful, the INST is newly registered, and the screen switches to the top page.

Note: If you recall and edit an INST here that’s not assigned to a pad, the INST assignment to the pad changes for the KIT. In this case, the KIT button blinks to indicate that the KIT has been edited. Write the KIT to memory if necessary. (→ p. 23, “Saving a KIT”)

Note: If you press the EXIT button to cancel the save operation and close the window and then press the EXIT button again, you can return to the previous page before the write operation begins.

Using the Looper function

The MPS-10 features a four-track looper. With the looper, you can record the same sound that's output from the MAIN OUT L (MONO), R jacks (what you play on the pads as well as the AUX IN/MIC IN input audio) for endless overdubbing.

While the looper is playing, you can use it to switch between KITS, for overdubbing sounds from different KITS or playing different KITS while the looper is playing back. Since it doesn't matter which of the four tracks you record first, you can start recording from any track.

Note: The metronome can't be recorded.

Overdubbing with the looper

When you record tracks on the MPS-10 using the looper, this is called "Rec" mode.

To start Rec mode, set SW MODE to "LOOPER" on the top page in KIT mode.

In this mode, the track 1-4 buttons serve as track buttons. The LED colors indicate the current status of each track, with the LEDs of the empty track buttons lighting up dimly in white.

1 Press an empty track button.

For this example, let's press the track 1 button. The LED for the button of the track you pressed and the REC button blink red, and the unit enters record standby.

2 Strike a pad or press the REC button to start recording.

Strike the pads to play.

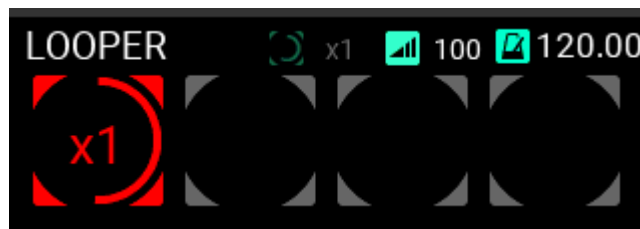

3 Once the first loop recording ends, the loop keeps playing and overdub recording begins.

The track 1 button lights up yellow at the same time as overdub recording begins.

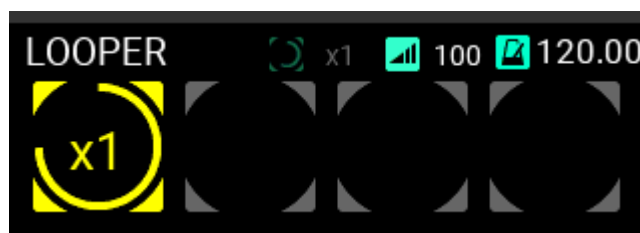

Tip: You can set the length of the first loop to record from the LOOPER Setup page in Utility.

4 Next, keep playing to record.

5 To stop overdub recording, press the track 1 button during overdub recording, or press the REC button.

Track 1 keeps playing back in a loop.

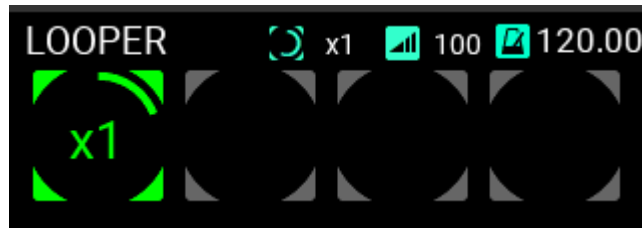

6 Press the track 1 button again to stop playback.

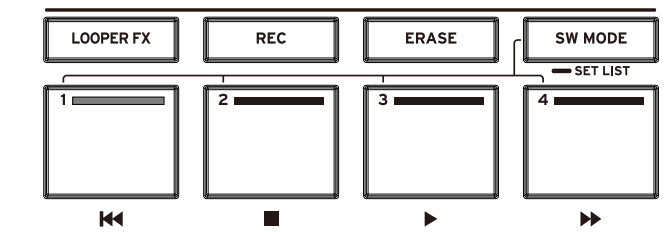

Record track 2 in the same way as a loop.

7 When recording track 2, you can set the length of the track's loop.

Track length setting

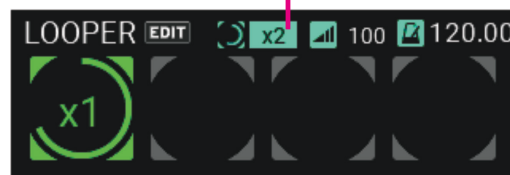

You can set the track length for loop recording as a multiple of track 1.

In this example, we use the "x2" setting to make the loop twice as long as track 1.

8 Record to track 2 using the same steps as you used for track 1.



On track 2, once you've recorded for twice the length of track 1, the unit switches to overdub mode.



Repeat these steps to record tracks 3 and 4.

Tip: The four tracks are set to “Sync” mode by default. Tracks that are set to “Sync” mode always begin in sync with each other when recorded or played back, and the track length is always either the same or a multiple integer of the first track that was recorded.

Refer to “LOOPER edit menu” (→ p.59) for details.

Details on looper operations

Track length in Sync mode

If a track has already been recorded, the track length for tracks set to Sync mode is either the same or is a multiple integer of the first track that was recorded. You can decide on the multiple for the track length by setting it beforehand.

Once the specified recording length elapses after recording begins, the looper automatically switches to Overdub mode. However, you can press the track button while recording if you want to quit.

In this case, recording stops when you press the track button (the track button starts blinking) and after the beginning of the track has passed. The track length is set at this point, and the looper switches to Overdub mode.

How the BPM and Beat settings work

Each KIT can have its own BPM and Beat setting. The looper length is determined by the BPM and Beat setting of the currently selected KIT.

However, by enabling Free Length on the LOOPER Setup page, you can set the looper length when the first track finishes recording, without having to set it beforehand.

You can change the BPM of the looper as you like when all tracks are empty. When you switch KITs in this state, the BPM setting of the KIT you switched to is also applied to the looper. (In the same way, the BPM for the KIT is also applied to the metronome.)

The timing settings are only loaded when you switch to a different KIT, so you can also change just the BPM for the looper.

However, once you record to a track, the looper BPM is fixed and does not follow any changes in KITs or metronome tempo.

The metronome BPM follows that of the KIT, but the metronome tempo follows the looper right when the looper begins recording. This tempo is maintained until you switch to a different KIT or change the tempo using the METRONOME knob.

Looper LCD screen display





When the looper is being used, the top page in KIT mode is divided into two sections (upper and lower). The KIT is shown above, and the looper information is shown below.



To change the track length and level from the top page, move the cursor with the VALUE knob and press the ENTER button to select.

You can change the parameters by turning the VALUE knob while it's selected.

The four circles shown on the “LOOPER” side indicate the status of the four looper tracks.

	Empty tracks are shown in gray.
	Tracks that are stopped are indicated by text inside the gray circles, which shows the track length.
	Tracks shown in red are now recording.
	Tracks shown in yellow are now overdubbing.
	Tracks shown in green are now playing.

For tracks in Play or Overdub mode, the green or yellow line inside the circle gets longer as the track cycles.

Also, if the looper length has already been set in Rec mode, the red line inside the circle indicates the looper length. Otherwise, “Rec” is shown in red letters.

The track length is shown at the center of each circle.

From the top page, you can set the length of all tracks that are in Sync mode.

When “Free” is shown, this means that the multiple for the track length has not been set beforehand.

With this setting, the track returns to the beginning after you finish recording, the recording stops and then the track length is set.

Tip: The factory default setting is “x1”.

Track button LEDs

While overdubbing

The REC button stays lit during overdubbing as well, and the track button lights up yellow.

When you press the track button for a track that’s overdubbing, overdubbing stops, the track returns to Play mode and the LED changes from yellow to green.

Playing

The track buttons for tracks that are now playing light up green. When you press the track button for a track that’s playing, the track stops and the LED changes to dark green.

While stopped

The track buttons for tracks that are stopped light up dark green.

When you press the track button for a track that’s stopped, the track starts and the LED changes from dark green to green.

If there are no tracks already playing at this time, playback starts from the beginning of the track.

If a track is already playing (for example, track 1) and another track whose button you pressed (for example, track 2) is in Sync mode, track 2’s play position synchronizes with track 1, and track 2 starts playing back from that point.

If the track whose button you pressed is in Free mode, that track will start playing from the beginning, without reference to the current playback position.

Track modes

The looper tracks feature two modes, Loop mode and One Shot mode.

Loop mode

Loop mode includes two settings, “Sync” and “Free”.

With the “Free” setting, the track always starts from the beginning regardless of the state of the other tracks or the BPM, and its length is set when recording stops. Also, the track plays back from the beginning when you press the track button, regardless of the state of the other tracks.

The length of the track when set to “Free” is not affected by other tracks, and it can be played back and stopped separately from the other tracks.

For tracks set to “Sync”, the track length is the loop length that you initially set, and you can synchronize multiple tracks for recording/playback.

Even if you set the loop length to a value other than “x1” and create a loop track whose length differs from the first track you recorded, the “Sync” setting lets you play back and record tracks in time with the other tracks.

If you start recording with a track set to “Sync” while other tracks are playing, the recording starts in sync with the track or tracks that are now playing, not from the beginning of the track. Also, the start of playback is synchronized with the track that’s playing back, and all tracks set to “Sync” play through the beginning at the same time without getting out of sync.

Tip: All four tracks are set to “Sync” by default.

One Shot mode

Tracks set to One Shot mode start recording or playback in the same way as with the “Free” setting, but they stop when recording is stopped. When playing back, these tracks do not loop, but instead play back just once before stopping. If you press the track’s button while it is playing back, playback stops.

Refer to “LOOPER edit menu” (→ p.59) for details on the various settings.

Recording play/stop

You can use an external audio signal input or play a pad to trigger the start of recording, and you can strike a specified pad to stop recording. You can also set a foot switch to trigger the start of recording.

Length of track to record

With the default settings, when you press the track button for a track that’s recording, recording stops, the track switches to Overdub mode and the LED changes from red to yellow.

The unit operates as follows when you record with all tracks empty.

- **Setting the track length ahead of time**

If the Free Length setting is disabled, overdubbing begins automatically once you’ve recorded up to the predetermined length.

- **Leaving the track length undecided**

If the Free Length setting is enabled, the track length is determined once you press the track button, and then overdubbing begins.

After that, this track length is used as the base until all tracks are empty, and the BPM of the looper is shown as the value calculated from this track length.

Erasing recorded tracks

The ERASE button on the control panel is used for erasing the contents of a track or for switching to Erase Rec mode. The button works differently depending on the looper state.

Erasing while the looper is playing back or stopped

When you press the ERASE button, the LED on the button blinks.

Press a track button in this state to erase the contents of that track.

The buttons of the erased tracks light up dimly in white, and the ERASE button goes dark, returning to its normal state.

Erasing during recording

When you press the ERASE button while recording, the recording is instantly canceled and the track contents are erased.

Erasing during overdubbing

When you press the ERASE button while overdubbing, the contents of everything you've recorded as an overdub thus far are erased, and the track returns to how it was before you started overdubbing. The unit remains in Overdub mode even after you erase data in this way.

Erase Rec

Similar to punch-in or replacing parts of a track, Erase Rec lets you record new parts to a track while recording over the existing data.

When you press the REC button while Erase Rec (UTILITY - LOOPER Setup) is "ON", the REC and ERASE buttons blink, and the unit enters Erase Rec standby mode.

Tip: You can also press both the REC and ERASE buttons at the same time to enter Standby mode.

At this time, when you press the button for a track that's already recorded, Erase Rec starts instead of Overdub.

The operations you use to start and end recording, as well as the actions afterwards are the same as Overdub mode. However, while Overdub mode lets you overlay what you play on the existing tracks, Erase Rec erases over the recorded data as you're recording new data.

This method of replacing what you've recorded is similar to punching in and out on an MTR (multi-track recorder).

Once you pass through the track with Erase Rec and return to the point where you started recording, the ERASE button goes dark and the unit switches to Overdub mode.

Looper effects

The looper features a dedicated built-in effects section for the output. You can turn this on or off at any time by pressing the button on the control panel.

Refer to "LOOPER edit menu" on page 59 for details on the effect settings.

Sampler

On the MPS-10, you can sample the sounds of the built-in sound generator as well as the external input audio signals from the LINE IN and MIC IN jacks, and assign them to the pads.

Sampling

Press the SAMPLE button to enter SAMPLE mode.

If you're not in SAMPLE mode, press the SAMPLE button.

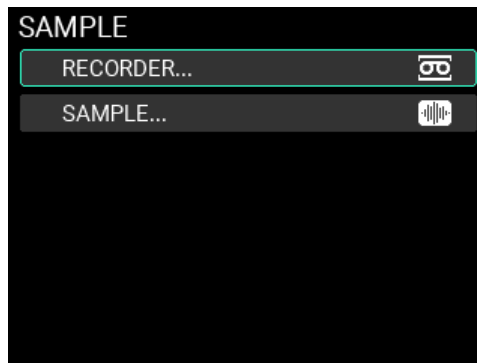

Select "RECORDER" or "SAMPLE" with the VALUE knob, and press the ENTER button to go to the RECORDER or SAMPLE page.

On the RECORDER and SAMPLE pages, the track 1-4 buttons operate as transport buttons.

Track 1 button: press once to go back a little, press and hold to rewind, or press twice to go back to the beginning (while stopped)

Track 2 button: play/record stop

Track 3 button: play/record start

Track 4 button: press once to go forward a little, press and hold to fast-forward

Aside from sampling, in SAMPLE mode you can also edit the existing user samples.

Note: You can't edit the preset samples.

Displaying the SAMPLE edit menu and editing

Here's how to sample a new sound to create a SAMPLE. The maximum recording time per SAMPLE is 60 minutes.

- 1 Press the SAMPLE button.
- 2 With the cursor positioned at "RECORDER", press the ENTER button.

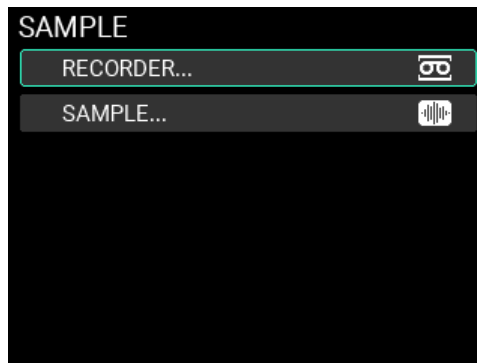

- 3 This accesses the RECORDER page. With the cursor positioned at "Make," press the ENTER button. You can now select from one of three sampling modes, as shown below.

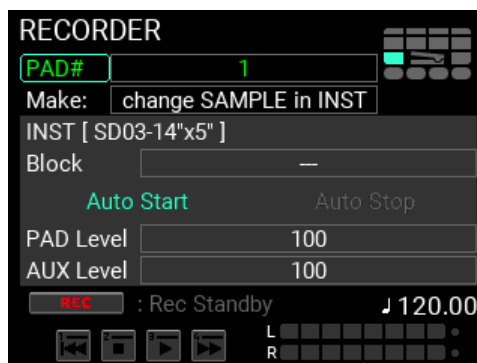

change SAMPLE in INST: Creates a new SAMPLE, and exchanges it with the SAMPLE that's set in the INST that's already registered.

new SAMPLE & INST: Creates a new SAMPLE and creates a new INST for which only that SAMPLE is set.

only new SAMPLE: Creates a new SAMPLE only.

For this example, we select "new SAMPLE & INST".

- 4 To choose the pad to strike when editing the SAMPLE, move the cursor to "PAD #" and specify the pad number.

Note: The pad you last struck before entering SAMPLE edit is the target pad.

- 5 When the "Make" setting is "new SAMPLE & INST", move the cursor to "INST" and press the ENTER button to open the category selection page. Select the category where you want to save the new INST. (You can also create new categories.)

- 6** When you confirm the save destination category, the page for inputting the new INST name is shown. Name the INST and press the ENTER button.
 Once the INST name is confirmed, the screen returns to the RECORDER page, and the INST name in the register destination is shown within the brackets for the INST.
 When the “Make” setting is “change SAMPLE in INST”, move the cursor to “INST” and press the ENTER button to select the edited INST. Then, select the block within the selected INST.
 After selecting, the INST name in the register destination is shown within the brackets for the INST, and the block position is shown underneath.
 If “Make” is set to “only new SAMPLE”, you can’t specify the “INST” and “Block”.

- 7** Check the level meters while playing the instrument on the MPS-10, playing back the sound from an external sound generator connected to this unit or by other means. If the levels are too low or are clipping, adjust the “PAD Level” and “AUX Level” settings to an appropriate level.

- 8** Next, press the REC button to enter Rec Standby mode.

Now you’ve finished getting ready to sample.

- 9** You can start sampling by pressing the track 3 button. However, since “Auto Start” is enabled by default, you can start sampling just by striking a pad, or start sampling automatically with an audio input signal from the LINE IN/MIC IN jacks.

Tip: Refer to “SAMPLE edit menu” (→ p.62) in this manual for details on Auto Start/Stop and other settings during recording.

- 10** To finish sampling, press the track 2 button to stop.







When sampling stops, the screen switches to “RECORDED SAMPLE” (SAMPLE EDIT mode).

Press the track 3 button to listen to the RECORDED SAMPLE.

Note: If there isn’t enough free space in the internal memory, sampling ends and the unit switches to “RECORDED SAMPLE”.

Tip: To redo sampling, press the EXIT button to go back to the RECORDER page.

Below is an explanation of the transport buttons.

	The unit is stopped. Press the  (track 3) button to begin playback.
	Playing
	Fast-forward while playing
	Rewind while playing
	Pause
	Fast-forward while pausing
	Rewind while pausing

Adjusting the start point and end point

- 1 On the RECORDED SAMPLE page, a window appears that shows the sampled waveform.

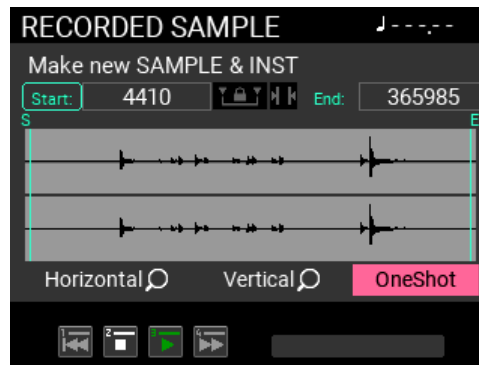

- 2 Adjust the sample's start position while using the VALUE knob to select Start, Scale, Horizontal and Vertical zoom parameters.

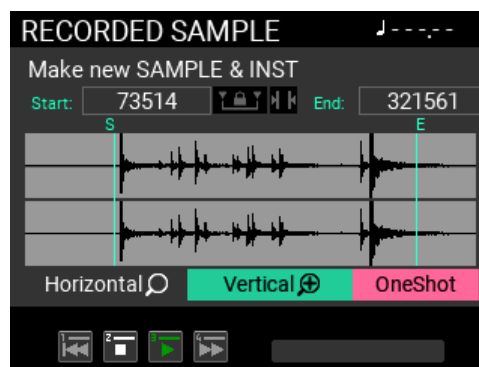

- 3 Move the cursor to "Start" and press the ENTER button. When you've decided on the start position, press the ENTER button again to confirm.

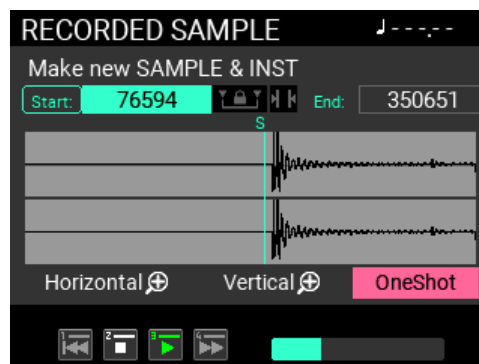

- 4 Adjust the end position in the same way.

You can use the to change the position, while setting a fixed interval for the Start/End positions.

You can use the to view the number of samples (size) between the start and end positions.

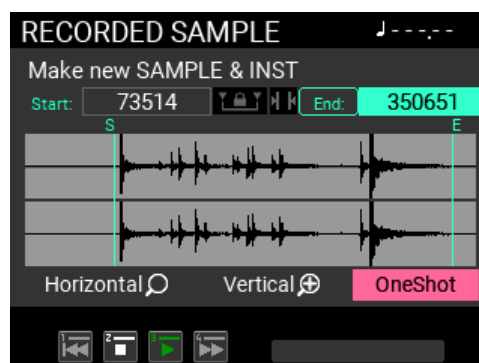

- 5 Move the cursor to the BPM and press the ENTER button. A window is shown on the page, where you can set the Measure (number of measures) and Beat (time signature). When you set the Measure and Beat, the BPM is automatically calculated and shown.

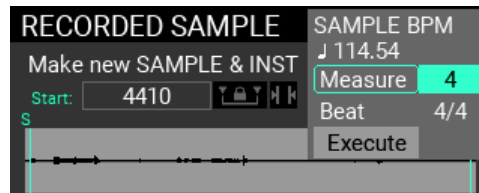

If Measure is "Off", the BPM is disabled.

- 6 You can check the adjustment as needed by using the track button transport function.



Move the cursor to select "OneShot" or "Repeat". This parameter applies to the playback transport function on this page.

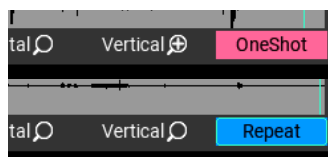

Editing SAMPLE data

Once you've finished sampling, use the following steps to delete (truncate) the unwanted portions of the SAMPLE data and to adjust (normalize) the SAMPLE to an appropriate level.

Note: If sampling ends because there isn't enough free space in internal memory, the SAMPLE EDIT page can't be shown.

- 1 After you've adjusted the Start/End positions, press the EDIT button to show the SAMPLE EDIT page.



- 2 On the SAMPLE EDIT page, select "Truncate..." and press the ENTER button to switch to the Truncate page.

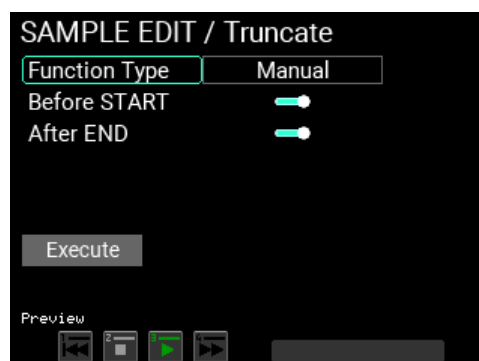

You can truncate in three different ways.

Manual: Deletes everything before the start point and after the end point.

Adjust to BPM: Deletes or adds empty data from/to the end of the SAMPLE data so that it matches the specified number of measures, time signature (beat) or the SAMPLE length specified by the BPM. When empty data is to be added and there is already data after the end point, that data is used instead.

Attack: Deletes the SAMPLE from the beginning to the point at which the SAMPLE reaches the level set for the Threshold.

In this example, we select “Manual”.

- 3** If the settings are acceptable, select “Execute” and press the ENTER button. The process is executed, and the screen returns to the SAMPLE EDIT page.

You can't restore a SAMPLE to its previous state after you execute the Truncate command. A Preview function is available for checking how the SAMPLE is going to sound after truncating. Use the track buttons to check the SAMPLE before you execute the Truncate command.

Tip: To cancel the Truncate command, press the EXIT button. No processing is done, and the screen returns to the SAMPLE EDIT page.

- 4** On the SAMPLE EDIT page, select “Normalize...” and press the ENTER button to switch to the Normalize page.

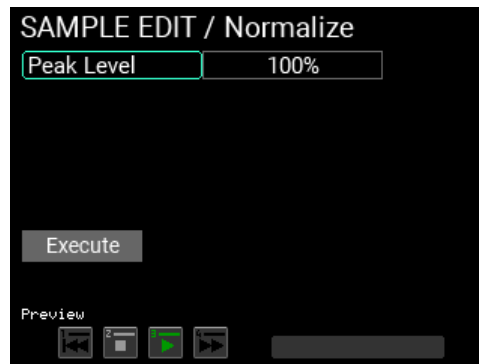

The Normalize command adjusts the overall levels for the SAMPLE data, so that the maximum level is the value specified in “Peak Level”.

For the Peak Level, the maximum value that the SAMPLE can reach without distorting is “100%”.

Note: This page also features a Preview function, which you can use to check the results before executing the command.

- 5** Select “Execute” and press the ENTER button. The process is executed, and the screen returns to the SAMPLE EDIT page.

To cancel the Normalize command, press the EXIT button. No processing is done, and the screen returns to the SAMPLE EDIT page.

You can also adjust the “Pitch” and “Time Stretch”. See p.62 “SAMPLE edit menu” in this manual for more information on editing the SAMPLES.

Saving a SAMPLE

To play the sounds you sample as part of a KIT, you must write the sampled data to the SAMPLE memory of the MPS-10.

- 1 Press the WRITE button on the SAMPLE EDIT page to show the SAMPLE WRITE page.

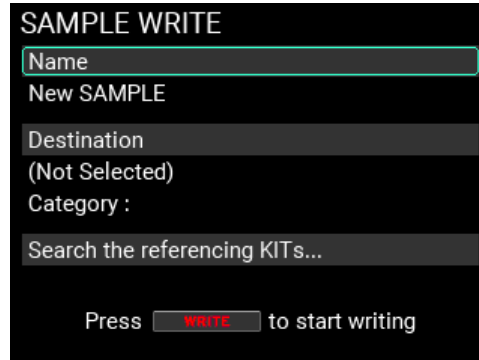

- 2 With "Name" selected, press the ENTER button to show the SAMPLE name edit screen (→ p. 24, "Using the Name dialog box (how to change the name)").

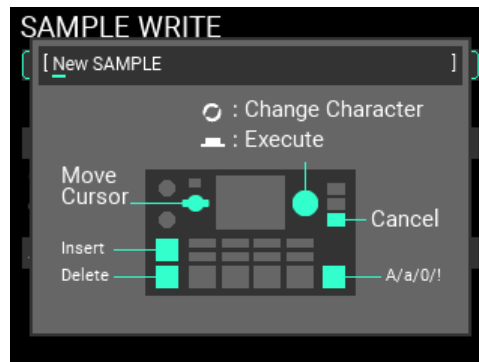

Once you've finished inputting the SAMPLE name, press the ENTER button to confirm.

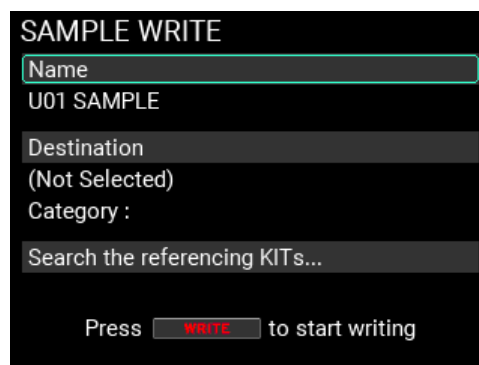

- 3 With "Destination" selected, press the ENTER button to show the page on which you can specify where to save the SAMPLE.

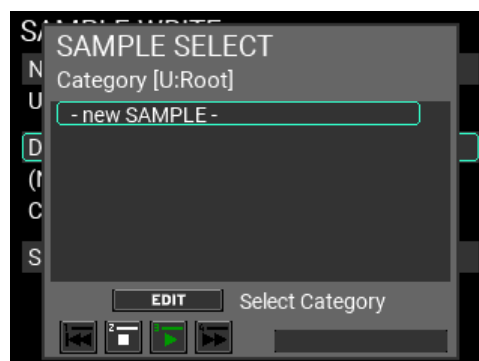

As we are creating a new SAMPLE here, select “- new SAMPLE -”.

Tip: To change the category, press the EDIT button on the screen shown above and select the save destination category. You can also create new categories.

- 4 Press the WRITE button again once you’ve confirmed the SAMPLE name to save and the save destination.

An alert window appears as shown here. To write the data, press the ENTER button. To cancel, press the EXIT button.

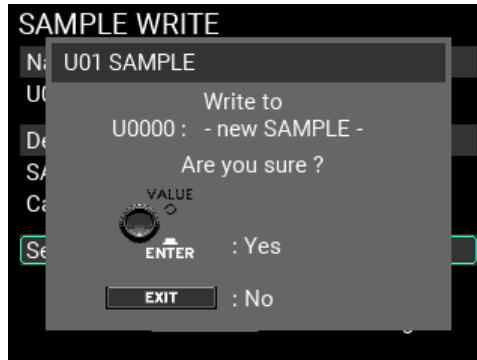

- 5 If the write operation is successful, the SAMPLE file is created, and the screen switches to the SAMPLE top page.

If you press the EXIT button to cancel the write operation, close the window and then press the EXIT button again, you can return to the previous page before the write operation begins.

See p.55 “INST edit menu” in this manual for more information on editing the INSTs.

Importing and exporting the SAMPLE data

See p.78 “Import & Export / SAMPLE” for more information on importing and exporting the SAMPLEs.

Parameter guide

KIT EDIT menu

The parameters you can edit using the KIT EDIT menu are shown below.



Note: Some settings may produce distortion or noise.

KIT Level.....0...100

Sets the overall volume of the instruments for the currently selected KIT.

BPM Base Pad#.....No Assign, 1...10, A, B, C, D, Pedal

Selects the pad that's used for detecting the base BPM of the currently selected KIT. The KIT's BPM is set to the BPM used by the INST that's assigned to the specified pad.

KIT EDIT / CC PAD

Use this to set the respective functions for CC (continuous control) pads 1-4: TRANS (Transpose), NOTE (Note Delay), MFX and FILTER.

Use the METRONOME knob on the CC PAD edit menu page to switch between the four pages.

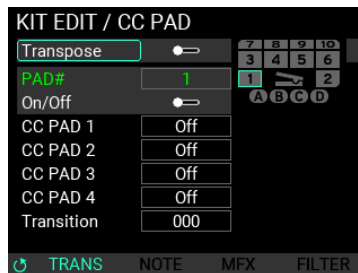

Tip: You can also use track buttons 1-4 to turn these functions on/off.

TRANS (Transpose)

Transpose On, Off

Enables/disables the function that changes the pitch you hear when the sounds play.

You can select a transpose value that's set when you play each of the four CC pads.

PAD#1...10 / A, B, C, D / Pedal

You can also turn the function on/off for each pad, which sets whether to transpose the sound. The pads for which this function is "On" are indicated in blue on the screen, which means that the pitches for these sounds are controlled by CC PAD.

On/Off (Pad Transpose) On, Off

Use this to select whether the Transpose function is used when the respective pad plays.

CC PAD 1...4 Off, -24...+12

Sets the transpose value (in semitones) that's used when you strike the CC pads.

Transition 0...100

Sets the speed at which the parameter value changes when you strike a CC pad.

Larger values make the values change slower.

Note: Sounds that are already playing do not change in pitch; only the pitches of new sounds that are played change.

NOTE (Note Delay)

This function automatically repeats the note you played once, only for the specified length.

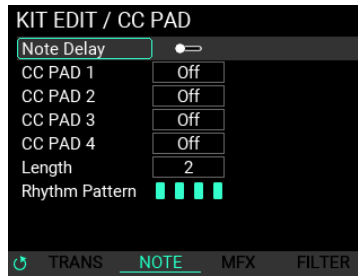

Note Delay On/Off On, Off

Enables/disables the Note Delay function.

Note Delay CC PAD1...4 Off, 8, 16, 32, 64, Hi

Sets the note value for the repeating notes that play when you strike the CC pads. The tempo is synchronized to the current BPM setting.

Note Delay Length 1...4

Specifies the length of the repeated notes, in quarter note units. The tempo is synchronized to the current BPM setting.

Note Delay Rhythm Pattern 1...4

You can set how the notes repeat, using one of four patterns. The available patterns are XXXX, X0XX, XX0X and XXXO (with "X" meaning that a note plays, and "O" meaning a rest).

MFX

You can apply an offset to two of the parameters included in the MFX. This offset changes according to where you strike the pads.

Note: This is disabled if the MFX for Main FX is set to "Off". Select the appropriate type and then set the MFX to "On".

Tip: Press the EDIT button to jump to the MFX page of Main FX.

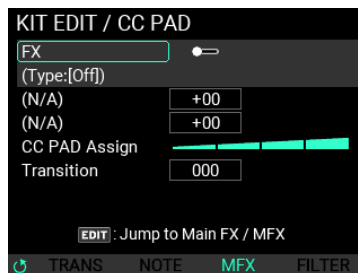

FX On, Off

Enables/disables the FX function.

Offset Param1 -100...+100

Offset Param2 -100...+100

Sets the maximum offset value for the CC pads.

The parameter contents change according to the effect type set for the MFX.

CC PAD Assign (1..9)

You can set one of the nine patterns below, which are used for changing the parameter contents according to where you strike the pads.

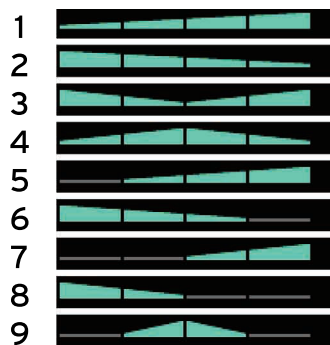

The corners of the triangles represent the minimum offset, and the sides of the triangles represent the maximum offset.

Tip: On the pads indicated in gray, the offset value is reset when you strike the location in question, which lets you revert the parameter settings to those saved in the KIT.

Tip: The setting for which the triangle is split in two is a symmetrical setting, which prevents the value from drifting when you're playing rolls with two sticks.

Transition 0...100

Sets the speed at which the parameter value changes when you strike a CC pad.

FILTER

You can apply an offset to two of the Filter effect parameters (Cutoff and Resonance) in the MFX. This offset changes according to where you strike the pads.

Note: This is disabled if the Filter for Main FX is set to "Off". Select the appropriate Filter type and then set the Filter to "On".

Tip: Press the EDIT button to jump to the Filter page of Main FX.

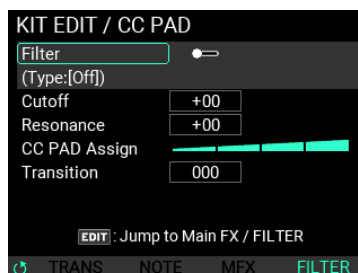

Filter On, Off

Enables/disables the Filter function.

Cutoff Freq -100...+100

Sets the maximum offset value for the filter's cutoff frequency, when using the CC pads.

Resonance -100...+100

Sets the maximum offset value for the filter's resonance, when using the CC pads.

CC PAD Assign (1..9)

You can set one of the nine patterns below, which are used for changing the parameter contents according to where you strike the pads.

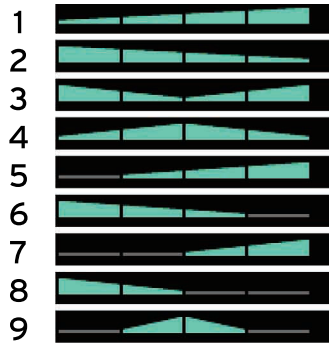

The corners of the triangles represent the minimum offset, and the sides of the triangles represent the maximum offset.

Tip: On the pads indicated in gray, the offset value is reset when you strike the location in question, which lets you revert the parameter settings to those saved in the KIT.

Tip: The setting for which the triangle is split in two is a symmetrical setting, which prevents the value from drifting when you're playing rolls with two sticks.

Transition 0..100

Sets the speed at which the parameter value changes when you strike a CC pad.

KIT EDIT / Foot SW

You can set which functions are used when an external switch is connected.

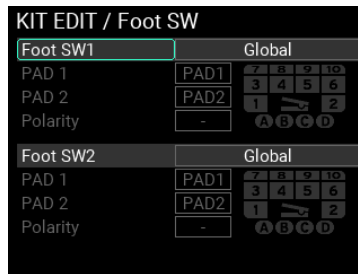

Foot SW1,2..... Global, KIT+, KIT-, IFX1 On/Off, IFX2 On/Off, LooperPlay Start/Stop, LooperRec Start/Stop, Tap Tempo, SOUND OFF, PAD Exchange

Sets which function to assign to the connected switch.

Note: There are also foot switch settings in UTILITY. When set to "Global", the settings in UTILITY are applied. (→ p.74)

When you select "PAD Exchange", the three parameters (PAD 1, PAD 2 and Polarity) shown below are enabled.

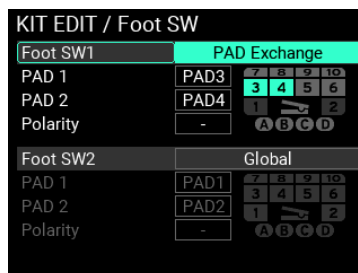

PAD1..... PAD1...PAD10 / A, B, C, D / Pedal

PAD2..... PAD1...PAD10 / A, B, C, D / Pedal

Selects the pad that switches when you operate the foot switch.

Polarity..... -, +

Lets you change the foot switch direction in which PAD 1 switches with PAD 2.

-: The pads switch when you release the foot switch.

+: The pads switch when you press the foot switch.

Note: The pad in question is shown in dark gray when “PAD Exchange” is configured on the expression pedal side. To avoid duplicating the PAD Exchange settings for a pad, you cannot select a pad shown in dark gray.

KIT EDIT / Exp Pedal

You can set the function that’s used when an external expression pedal is connected.

Pedal Assign

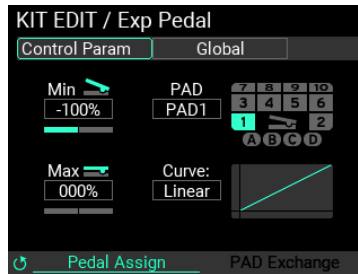

Control Param..... Global, Looper Volume, Filter Cutoff, Reverb Mix, PAD Decay, PAD Pitch

Sets which function to assign to the connected expression pedal.

Note: There are also expression pedal settings in UTILITY. When set to “Global”, the settings in UTILITY are applied.

To use the “PAD Exchange” function, you must use the METRONOME knob to navigate between pages and then configure the PAD EXCHANGE parameters.

Min..... -100%...+100%

Sets the minimum value for the pedal.

PADPAD1...PAD10/A,B,C,D/Pedal

Selects the target pad when “Control Param” is assigned to PAD Decay or PAD Pitch.

Max..... -100%...+100%

Sets the maximum value for the pedal.

Curve..... Linear, Exp1, Exp2, Exp3, Log1, Log2, Log3

Selects one of seven settings for the pedal output value curve.

PAD Exchange

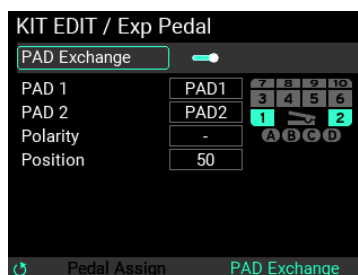

PAD Exchange On, Off

Enables/disables PAD Exchange.

Note: You can still use the “Control Param” function even if “PAD Exchange” is enabled.

PAD1..... PAD1...PAD10 / A,B,C,D / Pedal

PAD2..... PAD1...PAD10 / A,B,C,D / Pedal

Selects the pad that switches when you operate the pedal.

Polarity -, +

Changes the expression pedal direction in which PAD 1 switches with PAD 2.

Position 1...99

Adjusts the pedal position in which PAD 1 switches with PAD 2.

Note: The pad in question is shown in dark gray when “PAD Exchange” is configured on the foot switch side. To avoid duplicating the PAD Exchange settings for a pad, you cannot select a pad shown in dark gray.

KIT EDIT / EQ

This adjusts the EQ (equalizer) parameters for the currently selected KIT, which lets you calibrate the sound quality or make more aggressive changes to the sound.

You can make EQ settings separately for the Main, IFX1 and IFX2.

Use the METRONOME knob to switch between “to Main”, “to IFX1” and “to IFX2”. (All three effects use the same parameters.)

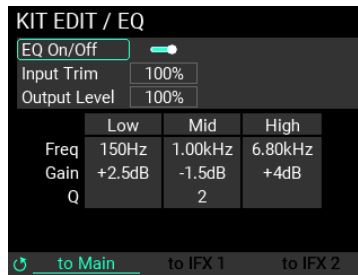

EQ On/Off On, Off

Enables/disables the EQ effect.

Input Trim..... 0...100%

Adjusts the input level going into the EQ. The sound may distort when using certain EQ settings. If this happens, use this parameter to adjust the level so as to avoid distortion.

Output Level 0...200%

Adjusts the EQ output level. As the output volume may change depending on the EQ settings, use this parameter to adjust the volume as appropriate.

Low Freq 60Hz...15.4kHz

Sets the frequency band for which the low end EQ is adjusted.

Low Gain -18dB ... +18dB

Boosts or cuts the low-end EQ frequency band (in 0.5 dB units).

Mid Freq 60Hz...15.4kHz

Sets the specific frequency band at which the EQ is adjusted.

Mid Gain -18dB ... +18dB

Adjusts specific EQ frequency bands upwards or downwards (in 0.5 dB units).

Mid Q..... 0.5...10

Adjusts the range around which the frequency set in Mid Freq is boosted or cut.
Larger values make the range narrower with steeper frequency characteristics (in units of 0.1).

High Freq 60Hz...15.4kHz

Sets the frequency band for which the high end EQ is adjusted.

High Gain -18dB ... +18dB

Adjusts the high end EQ frequency band upwards or downwards (in 0.5 dB units).

KIT EDIT / Insert FX

This section is for adjusting the Insert FX (hereafter “IFX”) parameters for the currently selected KIT. There are two IFX, and you can select the pads to which the IFX is applied from “PAD EDIT”. Use the METRONOME knob to switch between setting pages.

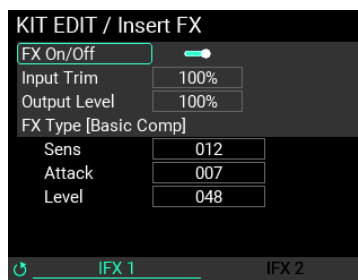

FX On/Off On, Off

Enables/disables the IFX effect.

Input Trim..... 0...100%

Adjusts the input level going into the IFX. The sound may distort when using certain IFX settings. If this happens, use this parameter to adjust the level so as to avoid distortion.

Output Level 0...100%

Adjusts the output level of the IFX. As the output volume may change depending on the IFX settings, use this parameter to adjust the volume as appropriate.

FX Type.....

Selects an insert effect. (Refer to the “Effect type list” in the preset list (PDF))

Param1,2,3 0...100

The contents of Param 1, 2 and 3 differ depending on the FX Type. When you change the FX Type, these parameters are reset to their default values.

For details on the parameters, refer to the “Effect type list” in the preset list (PDF).

KIT EDIT / Main FX

This section is for adjusting the Main FX parameters for the currently selected KIT.

There are three types of Main FX: “MFX”, “REVERB” and “FILTER”. Use the METRONOME knob to switch between setting pages.

MFX

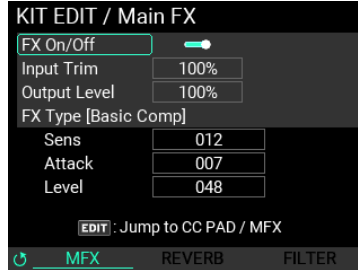

FX On/Off On, Off

Enables/disables the MFX.

Input Trim..... 0...100%

Adjusts the input level going into the MFX. The sound may distort when using certain MFX settings. If this happens, use this parameter to adjust the level so as to avoid distortion.

Output Level 0...100%

Adjusts the output level of the MFX. As the output volume may change depending on the MFX settings, use this parameter to adjust the volume as appropriate.

FX Type.....

Selects a main effect. (Refer to the “Effect type list” in the preset list (PDF))

Param1,2,3 0...100

The contents of Param 1, 2 and 3 differ depending on the MFX Type. When you change the Type, these parameters are reset to their default values.

For details on the parameters, refer to the “Effect type list” in the preset list (PDF).

Tip: Press the EDIT button to move to the CC PAD/MFX page. (→ p. 46, “MFX”)

REVERB

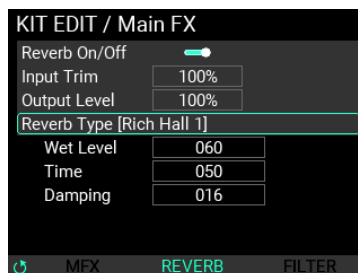

Reverb On/Off On, Off

Enables/disables the reverb.

Input Trim..... 0...100%

Adjusts the input level going into the Reverb. The sound may distort when using certain Reverb settings.

If this happens, use this parameter to adjust the level so as to avoid distortion.

Output Level 0..100%

Adjusts the output level of the Reverb. As the output volume may change depending on the Reverb settings, use this parameter to adjust the volume as appropriate.

Reverb Type

Selects the reverb effect. (Refer to the “Effect type list” in the preset list (PDF))

Param1,2,3 0..100

The contents of Param 1, 2 and 3 differ depending on the Reverb Type. When you change the Type, these parameters are reset to their default values.

For details on the parameters, refer to the “Effect type list” in the preset list (PDF).

FILTER

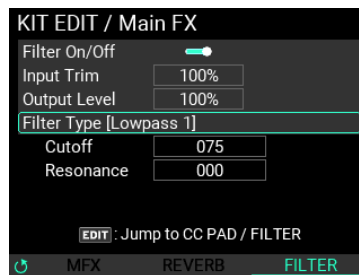

Tip: Press the EDIT button to move to the CC PAD/Filter page. (→ p. 47, “FILTER”)

Filter On/Off..... On, Off

Enables/disables the filter.

Input Trim..... 0..100%

Adjusts the input level going into the filter. The sound may distort when using certain Filter settings. If this happens, use this parameter to adjust the level so as to avoid distortion.

Output Level 0..100%

Adjusts the output level of the filter. As the output volume may change depending on the Filter settings, use this parameter to adjust the volume as appropriate.

Filter Type

Selects the filter type. (Refer to the “Effect type list” in the preset list (PDF))

Cutoff 0..100

Sets the frequency at which the filtering begins.

Resonance 0..100

Adjusts how much the frequencies around the cutoff frequency are emphasized.

PAD EDIT menu

Use the METRONOME knob on the KIT EDIT menu page to switch between the PAD EDIT menu pages. The parameters you can edit using the PAD EDIT menu are shown below.



PAD# 1...10 / A,B,C,D / Pedal

Selects the pad for which you wish to edit the settings.

INST[---].....

Selects the INST that's set for the pad.

Tip: The Loop/One Shot settings or the BPM may be shown, depending on the INST selected.

PAD Level 0...100

Sets the volume of the currently selected pad.

Pan L16...Center...R16

Sets the panning position (the left-right volume balance) for the currently selected pad.

Pad Mode Normal, Exclusive1,2, Series, Random, Latest

Sets the operating mode for the currently selected pad.

Normal: The normal state, in which the pad does not work in conjunction with other pads.

Exclusive1,2: With this setting, only one of the other pads in the same group can play at the same time. The last pad that you struck plays, and all other pads that had been playing up to that point are forcibly muted.

Series: Striking any pad in a group of pads sequentially triggers the other pads within the group.

Random: Striking any pad in a group of pads randomly triggers the other pads within the group.

Latest: The pad works the same as the last pad that was struck, instead of using its own settings.

Pitch Offset.....-24.00...+12.00

Adjusts the pitch of the currently selected pad.

Integers set the Transpose value (in semitones), and decimals set the Tune value" (in cents).

IFX Assign..... Off, IFX1, IFX2

Sets the IFX through which the currently selected pad is routed.

PAD Copy /Paste

When you press the EDIT button, the PAD Copy/Paste window appears. You can copy the contents of all the parameters of the selected pad to the clipboard, or paste the pad parameters in the clipboard to the selected pad. You can also paste pad parameters that you copied from other KITS.

INST edit menu

The parameters you can edit using the INST edit menu are shown below.

Note: Some settings may produce distortion or noise.

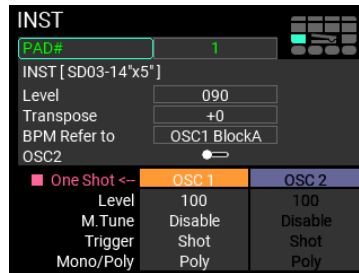

PAD# 1...10 / A,B,C,D / Pedal

Selects the pad for which you wish to edit the settings.

INST

Selects the INST to be edited. The selected INST name is shown in brackets.

Level..... 0...100

Sets the overall volume for the currently selected INST.

Transpose -24...+12

Sets the overall pitch for the selected INSTs.

BPM Refer to..... OSC1 BlockA...H, OSC2 BlockA...H

Selects the block that refers to the base BPM that's used for the currently selected KIT.

OSC2..... On, Off

Enables/disables OSC2.

OSC1/2 Level..... 0...100

Sets the overall OSC volume for the currently selected INST.

OSC1/2 M.Tune..... Disable, Enable

This parameter determines whether to control or not control the pitch in sync with Master Tune in UTILITY.

OSC1/2 Trigger Type Shot, Alternate

Sets the OSC trigger state for the currently selected INST.

Shot: The note plays again if you strike the pad while the sound is still playing.

Alternate: The note stops if you strike the pad while the sound is still playing.

OSC1/2 Mono/Poly Poly, Mono, Repeat

Sets whether each OSC plays in mono, poly or repeat mode.

Note: If only one of the OSC is set to "Repeat", that INST becomes a "Repeat INST".

Note: For the OSC that's set to "Repeat", you can only select "Alternate", not "Shot".

INST / Velocity

Sets the velocity curve for each OSC.

You can set the minimum, midpoint and maximum velocity, and edit the curves between these points. These settings let you make changes to the volume according to how hard you strike the pads.

Tip: Press the EDIT button in the instrument’s edit menu page to go to the “Velocity” page, and press the EXIT button to return.

Tip: There are three settings: “Velocity”, “Block Layout” and “Block Edit”. Use the METRONOME knob to switch between setting pages.

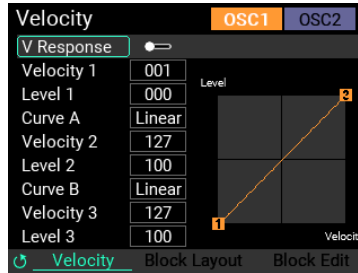

EDIT OSC SELECT.....OSC1, OSC2

Switches between OSC on the same page to edit.

Note: When you select OSC1 and then switch pages, you can make the Block Layout and Block Edit settings for OSC1.

V Response On, Off

Enables/disables the Velocity parameter for each OSC.

Velocity 1 1..127

Sets the velocity value of the first point for each OSC.

Level 1 0..100

Sets the level of the first point for each OSC.

Curv A..... Linear, Exp1, Exp2, Exp3, Log1, Log2, Log3

Sets the velocity curve from the first to the second point.

Linear		Log1	
Exp1		Log2	
Exp2		Log3	
Exp3			

Velocity 2 1..127



Sets the velocity value of the second point for each OSC.

Level 2 0..100

Sets the level of the second point for each OSC.

Curv B..... Linear, Exp1, Exp2, Exp3, Log1, Log2, Log3

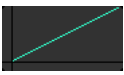
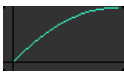
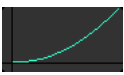
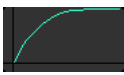
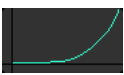
Sets the velocity curve from the second to the third point.

Linear		Log1	
Exp1		Log2	
Exp2		Log3	
Exp3			

Velocity 3 1...127

Sets the velocity value of the third point for each OSC.

Level 3 0...100

Sets the level of the third point for each OSC.

INST / Block Layout Edit

You can use up to eight SAMPLEs to configure the sound layout for each OSC.

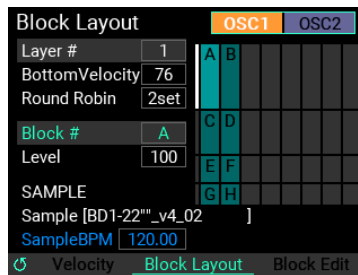

In the graph shown here, the Y-axis indicates the velocity and the X-axis indicates "Round Robin". The brightly highlighted light-blue blocks indicate the currently selected block, and the white line on the left side of the block indicates a currently selected velocity layer.

What's "Round Robin"?

"Round Robin" is a function that sequentially plays the specified blocks, even if the note was triggered within the same velocity layer. This reduces the unnatural sound that results from repeatedly triggering the same SAMPLE. You can also use this function to play different notes or instrument SAMPLEs each time you strike a pad, creating simple sequences.

Tip: Strike the specified pad repeatedly to play the SAMPLEs and hear how they sound. The block shown in white text is the last block that was played.

Layer # 1...8

Sets the number of the velocity layer (with each velocity layer represented by the rows on the screen) you want to edit. Although there are a maximum of eight layers (represented by the columns on the screen), you can use the "Round Robin" setting shown below to change the maximum number of layers (the "Layer #").

Note: For example, when you use all eight layers, you can't make more than one set with Round Robin.

Bottom Velocity..... 1...127

Sets the minimum (lowest) velocity value for the selected layer.

Round Robin 1..8set

Sets the number of round robins for the selected layer. Although there is a maximum of eight sets, you can use the “Layer #” setting shown above to change the “Round Robin” maximum value.

Block A..H

Selects the block to edit. You can edit up to eight blocks for each OSC.

Level..... 0..100

Sets the level for the selected block.

SAMPLE

Selects the SAMPLE to be used for the selected block. The selected SAMPLE name is shown in brackets. If BPM data is included in the SAMPLE, the BPM is also shown.

INST / Block Edit

Use this screen for editing a maximum of eight registrable blocks.

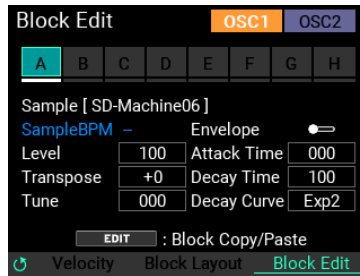

Blocks with the same velocity layer are marked with a white underline.

Unused blocks are grayed out.

Block A..H

Selects the block to edit. You can edit up to eight blocks for each OSC.

When you move the cursor to a block and press the ENTER button, that block is selected and highlighted, and its contents are shown below.

SAMPLE

Selects the SAMPLE to be used for the selected block. The selected SAMPLE name is shown in brackets. If BPM data is included in the SAMPLE, the BPM is also shown.

Tip: This works in conjunction with “SAMPLE” on the “Block Layout” page.

Level..... 0..100

Sets the level for the selected block.

Tip: This works in conjunction with “Level” on the “Block Layout” page.

Transpose -24...+12

Sets the Transpose for the selected block.

Tune 0..100

Sets the Tune for the selected block.

Envelope On Off

Sets the envelope for the selected block. When Envelope is turned on, the Attack Time, Decay Time and Decay Curve are enabled.

Attack Time 0..100



Sets the Attack Time for the selected block.

Decay Time.....0..100

Sets the Decay Time for the selected block.

Decay Curve..... Linear, Exp1, Exp2, Exp3, Log1, Log2, Log3

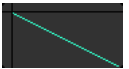
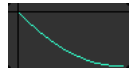
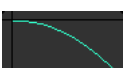
Sets the Decay Curve for the selected block.

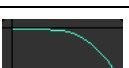
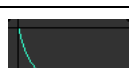
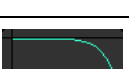
Linear		Log1	
Exp1		Log2	
Exp2		Log3	
Exp3			

Copy/Paste function

If you want to copy parameters from one block to a different block, you can make these settings using the Block Copy/Paste function. (Note that this is only for use within the same INST.)

When you select the copy source on the Block Edit screen and press the EDIT button, the “Copy/Paste” window opens as shown below.

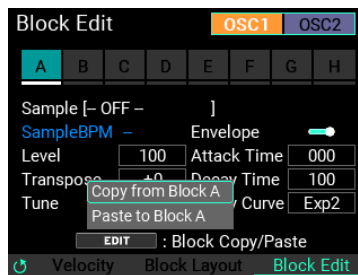

To retain the parameters for that block, move the cursor to “Copy” and press the ENTER button.

Next, select the copy destination block with the ENTER button and then press the EDIT button. The “Copy/Paste” window opens again.

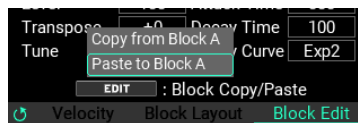

Move the cursor to “Paste” and press the ENTER button to paste the copy source parameters.

LOOPER edit menu

On the top page in KIT mode, set SW MODE to “LOOPER”, and use the VALUE knob to move the cursor to the track length or level. Press the EDIT button to open the LOOPER edit menu.

The parameters you can edit using the LOOPER edit menu are shown below.

Tip: You can also access the LOOPER parameter edit screen from UTILITY.

Tip: There are three types of LOOPER Setup screens: “LOOPER”, “TRACK” and “LOOPER FX”. Use the METRONOME knob to switch between setting pages.

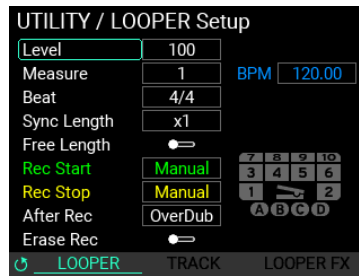

Level..... 0...100

This sets the overall volume for the looper.

Measure 0.5, 1...64

Sets the number of measures for recording to the looper.

Beat..... 1/2...24/2, 1/4...24/4, 1/8...24/8, 1/8t...24/8t, 1/16...24/16

Sets the time signature for recording to the looper.

Sync Length..... Free, x1...x32

Sets the loop length for the tracks from the second "Sync" settings track and up. The base loop length is the length that was first recorded.

BPM..... ---.-, 30.00...300.00

Shows the looper BPM.

The BPM shown is view-only, and cannot be edited on this page.

Free Length On, Off

Turn Free Length on if you don't want to specify the looper length ahead of time.

When you do so, the BPM appears as "---.-" in green text.

Once the first track finishes recording and the track length is established, the BPM is automatically calculated based on the track length along with the measure and beat that's set.

When you erase all tracks, the BPM shown in green displays again as "---.-".

Rec Start ..Manual, AUX, AUX/PAD, PAD All, PAD1...PAD10 / A,B,C,D / Pedal

Sets the base operation for starting the looper recording. When you specify a pad here, the pad that corresponds to the one shown on the right-hand pad view changes to green.

Rec Stop Manual, PAD1...PAD10 / A,B,C,D / Pedal

Sets the base operation for stopping the looper recording. When you specify a pad here, the pad that corresponds to the one shown on the right-hand pad view changes to yellow.

After REC OverDub, Play

Selects whether the track is set to "OverDub" or "Play" after recording ends.

Erase Rec On, Off

Normally, the notes you already recorded to a track are not erased when overdubbing. However, if you turn Erase Rec on, the previously recorded notes are erased as you record.

Also, when this is set to "Off", you can still turn Erase Rec on by pressing both the [REC] and [ERASE] buttons at the same time.

LOOPER Setup / TRACK

This screen lets you set the operating mode for each track.

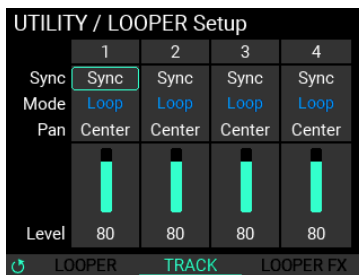

Sync Sync, Free

Sets whether the selected track operates in “Sync” mode (which synchronizes the track length and the transport start/stop timing) or in “Free” mode (which lets you use a track length and operation timing that’s not connected to other tracks).

Mode..... Loop, One Shot

You can set the looper for the selected track to operate in “Loop” mode (where the looper repeatedly plays back) or in “One Shot” mode (where the looper plays back once and then stops).

Pan L16...Center...R16

Sets the panning position (the left-right volume balance) for the selected track.

Level..... 1...100

Sets the volume of the selected track.

LOOPER Setup / FX

These settings are for configuring the looper effect.

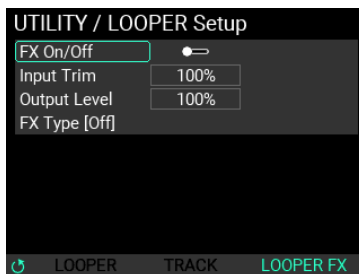

FX On/Off On, Off

Enables/disables the looper effect.

Input Trim..... 0...100

Adjusts the input level of the looper effect. The sound may distort when using certain effect settings. If this happens, use this parameter to adjust the level so as to avoid distortion.

OutPut Level..... 0...100

Adjusts the output level of the looper effect. As the output volume may change depending on the effect settings, use this parameter to adjust the volume as appropriate.

FX Type.....

This selects a looper effect. (Refer to the “Effect type list” in the preset list (PDF))

Param1,2,3 0...100

The contents of Param 1, 2 and 3 differ depending on the FX Type.

For details on the parameters, refer to the “Effect type list” in the preset list (PDF).

SAMPLE edit menu

The parameters you can edit using the SAMPLE edit menu are shown below.

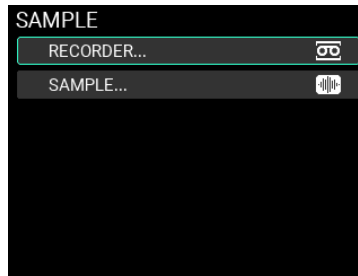

Note: Some settings may produce distortion or noise.

SAMPLE / RECORDER

Use this page for recording SAMPLEs.

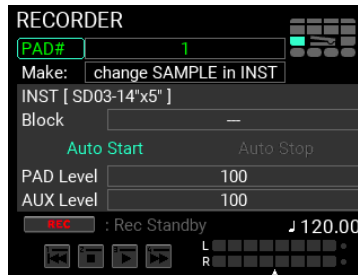

Make.....

Selects how newly recorded SAMPLEs are to be registered. You can choose from three modes.

change SAMPLE in INST: Creates a new SAMPLE, and exchanges it with the SAMPLE that's set in the INST that's already registered.

new SAMPLE & INST: Creates a new SAMPLE, and also creates a new INST in which that SAMPLE is set.

only new SAMPLE: Creates a new SAMPLE only.

Tip: When you choose "change SAMPLE in INST" or "new SAMPLE & INST" and create a SAMPLE, the new SAMPLE can be played on the specified page as soon as it's saved to memory.

Note: When you choose "only new SAMPLE" and create a SAMPLE, you can't play with that SAMPLE until you create an INST and KIT to which the SAMPLE is assigned.

INST

Editing is enabled when "change SAMPLE in INST" or "new SAMPLE & INST" is selected for "Make". This sets the INST to be edited or newly registered.

Block

Editing is enabled when "change SAMPLE in INST" is selected for "Make". This specifies the block for changing the INST to be edited.

Auto Start On, Off

Enables/disables auto-recording start.

Auto Stop On, Off

Enables/disables auto-recording stop.

Note: When Auto Stop is "OFF", recording automatically stops at a maximum of 60 minutes.

PAD Level..... 0...100

Sets the volume for each pad when recording.

AUX Level..... 0...100

Sets the input level of the external input to be recorded.

Note: The available LINE IN/MIC IN settings can be configured in UTILITY.

SAMPLE / RECORDER Setup

Use this page to make detailed settings when recording SAMPLEs.

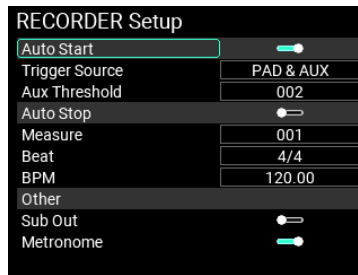

Auto Start On, Off

Turns the function on/off that automatically begins the recording.

This works in conjunction with “Auto Start” on the RECORDER page.

Trigger Source PAD, AUX, PAD&AUX

Sets the trigger used to automatically begin recording.

AUX Threshold..... 1...100

If AUX or PAD&AUX is selected in Trigger Source above, this sets the AUX INPUT level at which recording automatically starts.

Auto Stop On, Off

Turns the function on/off that automatically ends recording.

This works in conjunction with “Auto Stop” on the RECORDER page.

Measure 001... 999

Sets the number of measures to record before automatically stopping.

Beat..... 1/2...24/2, 1/4...24/4, 1/8...24/8, 1/8t...24/8t, 1/16...24/16

Sets the beat (time signature) when the recording is set to stop automatically.

BPM.....30.00...300.00

Sets the BPM used when the recording is set to stop automatically.

Note: You can’t configure the Measure, Beat and BPM settings in a way that would make the recording time exceed 60 minutes.

Sub Out..... On, Off

For the pads that are set to Sub Out output during recording, this sets whether to include the AUX IN output.

Metronome On, Off

Sets whether the metronome automatically starts during recording.

SAMPLE / SAMPLE

Use this screen to adjust the length of the recorded SAMPLE, set the loop and make other edits.

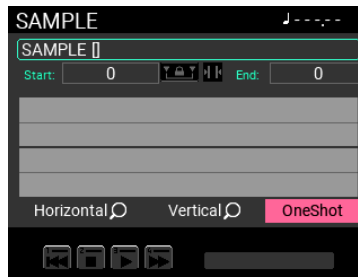

Note: To edit a SAMPLE, there must be enough equivalent free space in internal memory.

SAMPLE / SAMPLE EDIT

Four editing modes are available for editing the recorded SAMPLE.



Note: If there isn't enough free space available, you can't use some of the operations to change the SAMPLE length.

SAMPLE EDIT / Normalize

If the SAMPLE volume is too low, you can raise the volume to the point where the SAMPLE doesn't clip (distort).

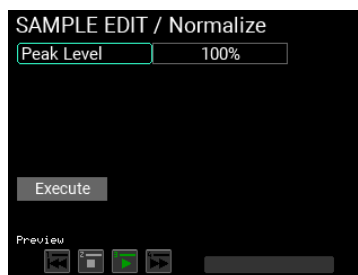

Peak Level1%...100%

Sets the peak volume level for the SAMPLE, as a percentage of the highest level at which the SAMPLE does not clip.

SAMPLE EDIT / Truncate

Use this to truncate (delete) the portions of the SAMPLE before the start point and after the end point that you set, according to the “Function Type” (explained below).

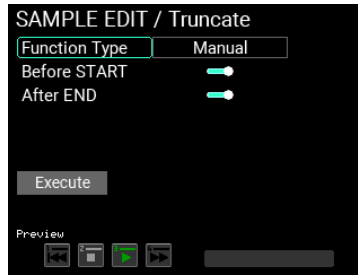

Function TypeManual, Adjust to BPM, Attack

Function Type: Manual

Truncates (deletes) the portions of the SAMPLE before the start point and after the end point that you set.

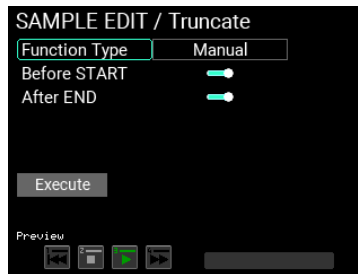

Before START On, Off

Enables/disables SAMPLE deletion prior to the start point.

After END On, Off

Enables/disables SAMPLE deletion after the end point.

Function Type: Adjust to BPM

Truncates or adds to the end of the SAMPLE data so that it matches the specified number of measures, time signature (beat) or the SAMPLE length specified by the BPM.

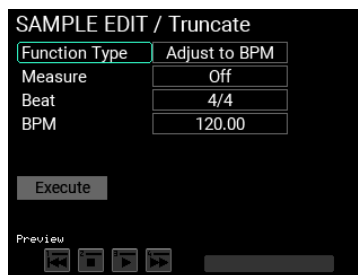

Measure Off, 0.5, 001...999

Sets the number of measures of the SAMPLE to be created.

Beat..... 1/2...24/2, 1/4...24/4, 1/8...24/8, 1/8t...24/8t, 1/16...24/16

Sets the beat (time signature) of the SAMPLE to be created.

BPM.....30.00...300.00

Sets the BPM of the SAMPLE to be created.

Function Type: Attack

Deletes the range of the SAMPLE from the beginning to the point at which the SAMPLE signal reaches the set Threshold level.

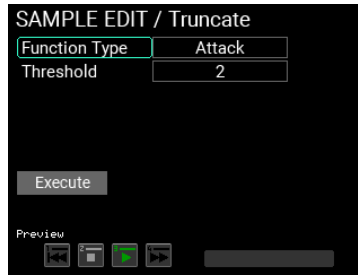

Threshold.....1...100

Sets the peak level of the start point.

SAMPLE EDIT / Pitch Edit

You can change the pitch of the SAMPLE.

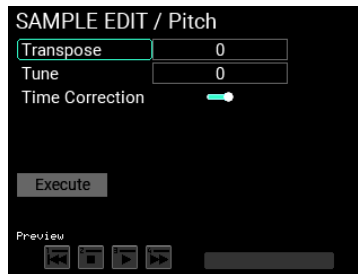

Transpose -12...+12

Adjusts the pitch of the SAMPLE in semitones.

Tune 0...+100

Adjusts the pitch of the SAMPLE in cents.

Time Correction On, Off

When this is enabled, you can change the pitch while maintaining the SAMPLE length (time).

SAMPLE EDIT / Time Stretch

You can change the length of the SAMPLE here.

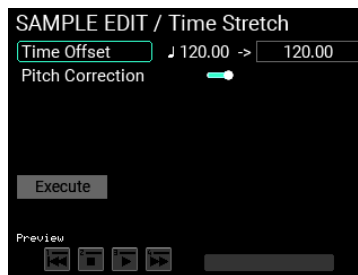

Time Offset 30.00...300.00

Sets the length of the SAMPLE, based on its BPM value.

The setting range for the SAMPLE length is 30.00-300.00, limited to a range within 1/2-2x. You cannot set the direction in which the SAMPLE is stretched when the length is set to 30.00. Also, you cannot set the direction in which the SAMPLE is compressed when the length is set to 300.00.

For SAMPLEs without a BPM setting, a setting of "120" is shown.

Pitch Correction On, Off

When this is set to on, you can change the sample's time while maintaining its pitch.

UTILITY menu

The UTILITY menu of the MPS-10 contains many functions and settings.

To use the UTILITY functions, press the UTILITY button to enter UTILITY mode.

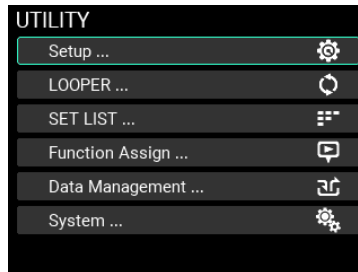

If you're accessing a page for which the UTILITY button is not lit, press the EXIT button repeatedly until you get to a page where the UTILITY button lights up.

Setup

From this screen, you can configure the pad triggers, audio input/output, metronome, MIDI, display indications and other functions.

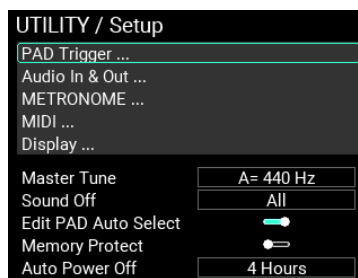

Master Tune 430 Hz...450 Hz

Lets you set the basic tuning of the MPS-10. (The default setting is "440 Hz".)

Note: When the "M.Tune" OSC setting for the INST is "ON", Master Tune is enabled.

Sound off All, Before KIT Change

Sets the function of the SOUND OFF button.

All: Stops the sound of all pads that are outputting sound.

Before KIT Change: Stops the sounds of the KIT you used before switching to a different KIT.

Edit PAD Auto Select..... On, Off

By striking the pad in the location where you can select the pad number, you can set whether to enable the pad selection function.

Memory Protect On, Off

Sets whether to prohibit the internal memory from being written to (overwritten).

Note: When this is on, you can't overwrite the KITS, INSTs or SAMPLEs. You can use the looper, but you can't use the Write function to write any data.

Note: You can save data in UTILITY mode (including looper setup and set list data) even when Memory Protect is "ON".

Auto Power Off Disable, 30 Minutes, 4 Hours

Sets whether the auto power-off function is enabled or disabled.

When the auto power-off function is enabled, the power automatically turns off when a certain length of time has elapsed since the pads were played or the unit was operated. (The default setting is “4hours”.)

Use the dial if you wish to change this to a different setting.

Note: The auto power-off count will be canceled under any of the following conditions:

When the panel is operated, a pad is triggered, the looper or a recorded SAMPLE is played back, the metronome is used, SysEx data is received via USB MIDI, or when an import/export is executed that includes SAMPLE data.

Setup / PAD Trigger

This screen lets you configure the trigger settings for each of the 15 pads built into the MPS-10.

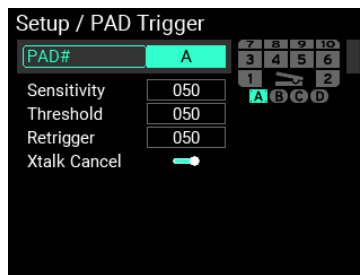

PAD# 1..10 / A,B,C,D / Pedal

Specifies the number of the pad for which you want to configure the trigger settings.

Note: You can change the pad number by striking the pads.

Sensitivity 0..100

Adjusts the trigger sensitivity.

Threshold 0..100

Adjusts the minimum striking force required to make the pad react. This has no effect on the pedal.

Retrigger 0..100

This makes adjustments to improve retriggering.

Note: Increase the retriggering value to avoid pads sounding two notes when played only once. Note that this will make the pad less able to detect drum rolls. When you lower this value, you will be able to play intricate flams, but the pad will be more likely to sound twice with one stroke.

XTalk Cancel On, Off

You can configure the MPS-10 to cancel out the resonance from other pads when a pad sounds.

Turn this on to reduce resonance. This is enabled when used with external triggers (A-D).

Note: When this is set to “On,” striking two pads at the same time may be considered as resonance, and the sound from one of the pads may not be heard as a result. If this happens, turn the setting off and check again.

Setup / Audio In & Out

Use this screen to edit the parameters related to audio input/output.

Tip: There are three “Audio In & Out” settings: “Input”, “Output” and “Out Routing”. Use the METRONOME knob to switch between setting pages.

Input

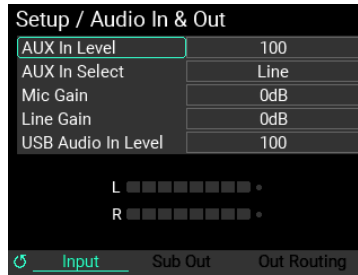

AUX In Level 0...100

Adjusts the signal volume for the jack selected in AUX In Select.

AUX In Select Line, Mic Unbalanced, Mic Balanced, None

Sets the jack used for AUX IN.

Line: Uses the audio input that’s connected to the LINE IN jack.

Mic Unbalanced: Uses the monaural mic input that’s connected to the MIC IN jack.

Mic Balanced: Uses the XLR mic input that’s connected to the MIC IN jack.

None: Disables audio input from the LINE IN and MIC IN jacks.

Mic Gain -12dB...32dB

This adjusts the input gain for the MIC IN jack.

Line Gain -12dB...32dB

This adjusts the input gain for the LINE IN jack.

USB Audio In Level 0...100

Adjusts the volume of signal input via USB audio.

Output

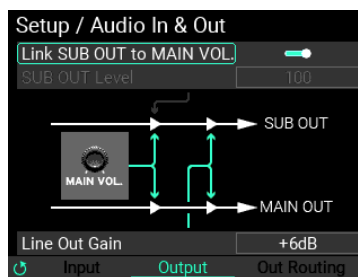

Link SUB OUT to MAIN VOL On, Off

You can set the MAIN VOL. knob on the panel to also change the SUB OUT when you move the MAIN VOL. knob.

SUB OUT Level 0...100

When “Link SUB OUT to MAIN VOL” is disabled, this adjusts the volume of signal that’s output from SUB OUT.

Line Out Gain -6dB, 0dB, +6dB, 12dB

Adjusts the volume of signal that’s output from MAIN OUT and SUB OUT.

Note: The -6dB setting outputs at around half volume, the +6dB setting is around twice the volume, and the +12dB is around four times the volume. Note that the signal tends to clip when you raise the volume too far.

Out Routing

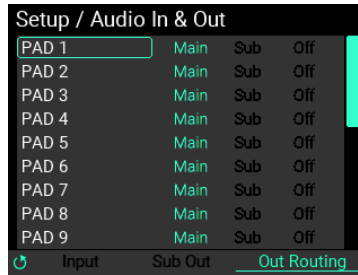

Use this screen to set the output destination for each pad, IFX 1, 2, the loop, metronome, AUX In and USB In.

Use the VALUE knob to select the output source, and press the ENTER button to toggle between “Main”, “Sub”, “Off” and “Main” settings.

Note: When Metronome, AUX In and USB In are set to “Off”, nothing is output from MAIN OUT or SUB OUT, but signal is output from PHONES.

Setup / METRONOME

This screen lets you configure the settings for the metronome built into the MPS-10.

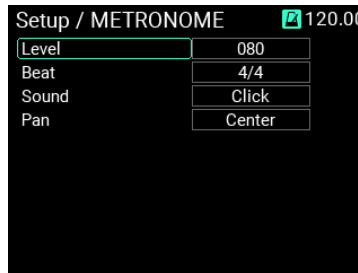

Level.....000...100

Adjusts the volume of the metronome.

Beat..... 1/2...24/2, 1/4...24/4, 1/8...24/8, 1/8t...24/8t, 1/16...24/16

Sets the metronome’s beat (time signature).

Sound.....

Selects the metronome sound (10 sounds are available).

For details on the parameters, refer to the “Effect type list” in the preset list (PDF).

Pan L16...Center...R16

Sets the metronome panning (left-right volume balance).

Setup / MIDI

Configures the settings for transmitting and receiving MIDI signals.

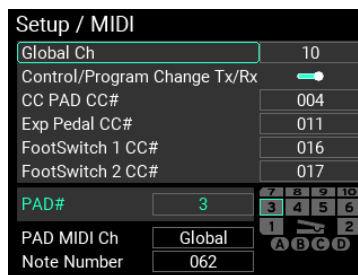

Global Ch 1...16

Specifies the MIDI channel of the MPS-10.

To receive/transmit program changes or other data via MIDI, set the MIDI channel of this unit to match the MIDI channel of the connected MIDI device.

Control/Program Change Tx/Rx On, Off

Sets whether program changes and control changes are transmitted and received.

CC PAD CC# 000...119

Sets the CC (control change) number that's output when you operate a CC pad, as well as the number that's used to control this unit from an external MIDI device.

Exp Pedal CC# 000...119

Sets the CC (control change) number that's output when you operate the expression pedal, as well as the number that's used to control this from an external MIDI device.

FootSwitch 1 CC# 000...119

Sets the CC (control change) number that's output when you operate foot switch 1, as well as the number that's used to control this from an external MIDI device.

FootSwitch 2 CC# 000...119

Sets the CC (control change) number that's output when you operate foot switch 2, as well as the number that's used to control this from an external MIDI device.

PAD# 1...10 / A,B,C,D / Pedal

Specifies the number of the pad for which you want to configure the MIDI settings.

Tip: You can change the pad number by striking the pads.

PAD MIDI Ch Global, 1...16

Sets the MIDI channel for each pad. Pads that are set to "Global" use the global channel specified in the global parameters.

Note Number 0...127

Sets the note number for each pad.

Setup / Display

Use this screen to configure the screen and LED display for the MPS-10.

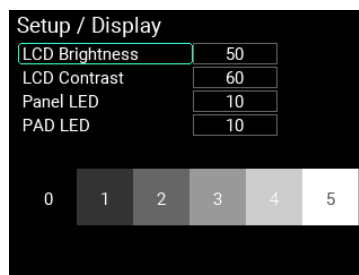

LCD Brightness 1...100

Adjusts the display backlight's brightness.

LCD Contrast 1...60

Adjusts the display contrast.

Panel LED 1...10

Sets the brightness of the panel LEDs.

PAD LED..... 1...10

Sets the brightness of the pad LEDs.

LOOPER

The MPS-10 features a four-track looper. With the looper, you can record the same sound that's output from the MAIN OUT L (MONO), R jacks (what you play on the pads as well as the AUX IN/MIC IN input audio) for endless overdubbing.

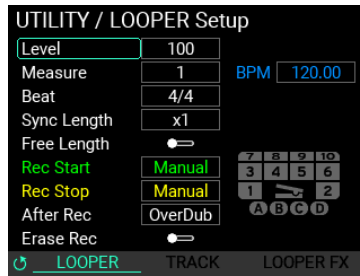

Refer to “LOOPER edit menu” (→ p.59) in this manual for the detailed settings.

SET LIST

The MPS-10 features a “set list” function, which lets you recall a set list of up to eight different KITs in the order that you like.



LIST Select.....1...8

Selects the set list you want to use out of the eight set lists that are registered.

LIST1...8.....

You can register up to eight set lists.

Using this unit with the set lists

When you select one of the lists (1-8), the screen switches to the set list edit page.

Register the KITs in the order you want within the selected set list. You can register up to 24 KITs.



Name [---]

Press the EDIT button to change the name of the selected set list. (→ p. 24, “Using the Name dialog box (how to change the name)”)

#, KIT Name.....

The numbers shown in the “#” column (01-24) represent the numbers within the set list. Use the VALUE knob to select the number of the KIT you want to edit in the set list, and press the ENTER button to edit the KIT whose number you selected.

Press the KIT + button to insert the currently selected KIT into the list.

Press the KIT - button to delete the currently selected KIT from the list.

Note: Once you’ve deleted all KITS from the list, that set list is deleted from the selectable set lists in LIST Select. However, you can’t delete the set list if it is the only remaining set list that can be selected.

Tip: When you delete all registered KITS to clear the list, that set list is deleted.

Function Assign

You can assign performance functions like KIT change, FX ON/OFF and so on to be triggered by the pads, foot switches and pedal.

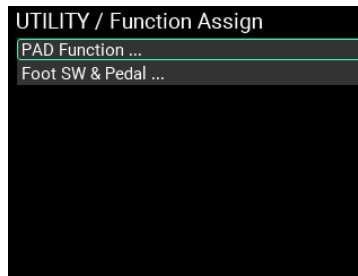

Function Assign / PAD Function

On this screen, you can assign the following functions to the 15 pads built into the MPS-10.

Tip: You can’t assign more than one function to the same pad.

Tip: “---” indicates that the function is not assigned to a pad.

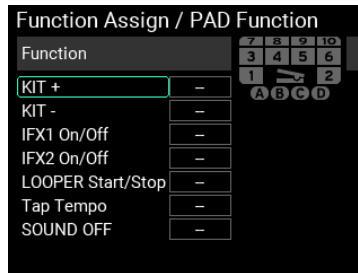

KIT+ PAD1...PAD10 / A,B,C,D / Pedal

Sets the pad that’s used for changing to the next KIT.

KIT-..... PAD1...PAD10 / A,B,C,D / Pedal

Sets the pad that’s used for changing to the previous KIT.

IFX1 On/Off..... PAD1...PAD10 / A,B,C,D / Pedal

Sets the pad that enables/disables Insert FX1.

IFX2 On/Off..... PAD1...PAD10 / A,B,C,D / Pedal

Sets the pad that enables/disables Insert FX2.

LOOPER Start/Stop..... PAD1...PAD10 / A,B,C,D / Pedal

Sets the pad that starts/stops the looper.

When you strike the pad that's specified here and multiple tracks are already playing, all tracks stop.

When you strike the pad while multiple tracks are stopped, all tracks begin playing.

Tap Tempo PAD1...PAD10 / A,B,C,D / Pedal

Sets the pad that adjusts the BPM via tap tempo.

SOUND OFF PAD1...PAD10 / A,B,C,D / Pedal

Sets the pad that works the same as the SOUND OFF button on the panel.

Function Assign / Foot SW & Pedal

On this screen, you can assign the following functions to the two foot switches and the expression pedal of the MPS-10.

Foot Switch

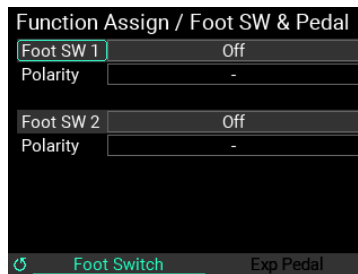

Foot SW1,2..... Off, KIT+, KIT-, IFX1 On/Off, IFX2 On/Off, LooperPlay Start/Stop, LooperRec Start/Stop, Tap Tempo, SOUND OFF

Use this to set which function to assign to the connected foot switches.

Polarity..... -, +

Lets you change the polarity of the function.

Set this according to the foot switch you're using.

Exp Pedal

Use the METRONOME knob to switch to the Exp Pedal page.

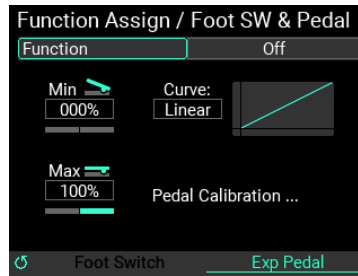

Function..... Off, Looper Volume, Filter Cutoff, Reverb Mix

Sets the function that's assigned to the expression pedal connected to this instrument.

Min.....-100%...+100%

Set the minimum value for the pedal.

Max.....-100%...+100%

Set the maximum value for the pedal.

Curve..... Linear, Exp1, Exp2, Exp3, Log1, Log2, Log3

Selects one of seven settings for the pedal output value curve.

Pedal Calibration

Select "Pedal Calibration" to calibrate the pedal that's connected.

How to calibrate the pedal

You can select "Pedal Calibration" to calibrate the expression pedal that's connected.

- 1 With the pedal pushed all the way down with your toes (maximum position), press the ENTER button.

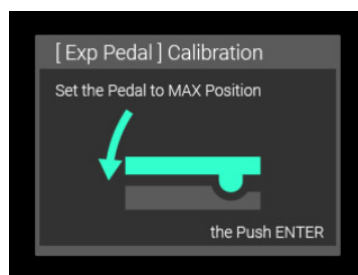

- 2 With the pedal pushed all the way down with your heel (minimum position), press the ENTER button.

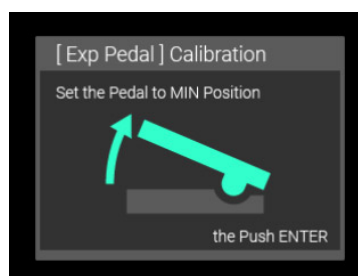

3 The calibration is finished when you see the message “Complete!”

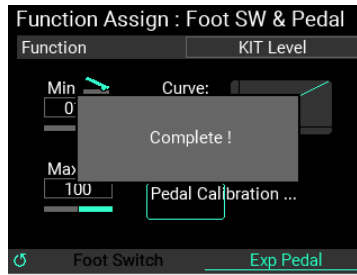

Data Management

From this screen, you can import, export, change the filenames and registered categories, delete and perform other operations on the various data used by the MPS-10. Connect a USB flash drive to this unit.

Note: You can't use the "Import & Export" functions if you haven't inserted a USB flash drive.

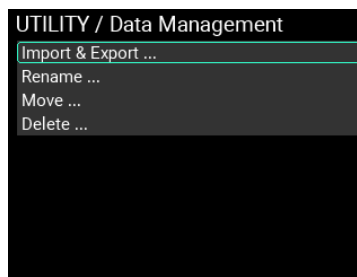

Import & Export

This screen is for exporting or importing the various data used by the MPS-10, to or from a USB flash drive.

Each data item used for "All User Data" and "LOOPER Data" contains multiple files, which are imported or exported all at once as a folder.

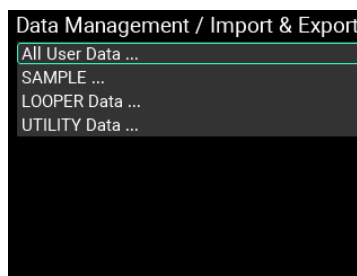

Import & Export / All User Data

"All User Data" includes all the settings and data (KITs, INSTs, SAMPLEs, looper and UTILITY) that are saved.

Move the cursor to "All User Data" on the Import & Export top page, and press the ENTER button to enter the Import & Export page for "All User Data".



How to import all user data

Here's how to import all user data into internal memory from a USB flash drive.

- 1 Move the cursor to "Folder" and press the ENTER button to show the list of "All User Data" folders that are saved to the USB flash drive.



- 2 Use the VALUE knob to select the "All User Data" set that you want to import, and press the ENTER button to confirm.
- 3 Move the cursor to "Execute" and press the ENTER button. A message is shown on the page, confirming whether you want to import the set of "All User Data".



Press the ENTER button to execute. Press the EXIT button to cancel.

Note: If you cancel the Import All User Data operation while it is in progress, all user data returns to the factory default settings.

How to export all user data

Here's how to save the current set of "All User Data" to a USB flash drive.

- 1 Turn the METRONOME knob to switch from the "Import" page to the "Export" page.

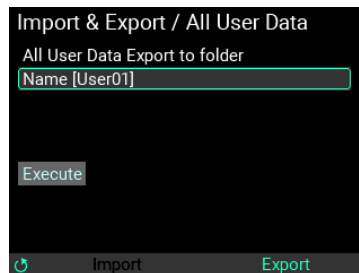

Move the cursor to "Name" and press the ENTER button to show the rename page. (→ p. 24, "Using the Name dialog box (how to change the name)")

- 2 Move the cursor to "Execute" and press the ENTER button. A message is shown on the page, which confirms whether you want to export the set of "All User Data". Press the ENTER button to execute. Press the EXIT button to cancel.

If there is already a file with the same name when you press “Execute”, the message shown below appears.



To overwrite the data, press the ENTER button. To rename the data, press the EXIT button.

Note: If you cancel the Export All User Data operation while it is in progress, the data with the specified name is deleted from the USB flash drive.

Note: SAMPLEs saved to this unit that have a long recording time might take a while to export when you use the “Export All User Data” command.

Note: To delete the data that’s saved, delete the subfolder with the name you specified in “Name,” located in the “ALL_DATA” subfolder of the “MPS_10” folder.

Import & Export / SAMPLE

The MPS-10 lets you import external SAMPLE data by using a USB flash drive and then assign this data to the pads, just like with the internal SAMPLEs.

The SAMPLEs that you create on this device can be exported as WAV files.

Note: Supported SAMPLE data formats are WAV or AIFF (16-bit, mono/stereo, 44.1/48 kHz, up to 60 minutes long).

Move the cursor to “SAMPLE” on the Import & Export top page, and press the ENTER button to enter the Import & Export page for “All User Data”.

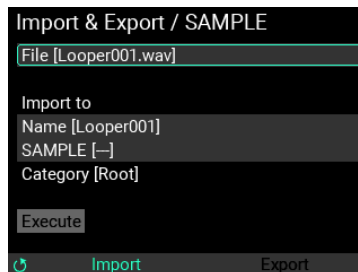

How to import SAMPLEs

Here’s how to import the SAMPLE data saved on a USB flash drive into the MPS-10.

- 1 Import the SAMPLE data file that’s saved to the USB flash drive into internal memory.

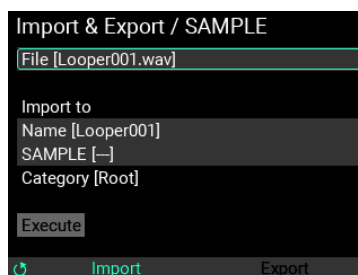

Note: Store the SAMPLE data files along with the folders that contain the SAMPLE data files in the “SAMPLE” subfolder, located in the “MPS_10” folder on the USB flash drive. Any other SAMPLE data files stored on the USB flash drive are not imported into the MPS-10.

- 2 Move the cursor to “File” and press the ENTER button to show the list of SAMPLE data files and folders that are saved to the USB flash drive.

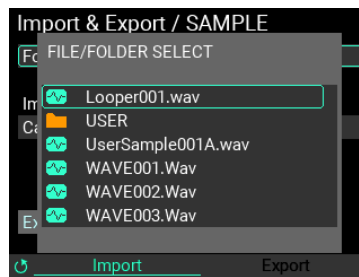

Use the VALUE knob to select the SAMPLE data files and folders that you want to import, and press the ENTER button to confirm. This works differently depending on whether you're importing SAMPLE data files or folders.

Tip: SAMPLE data files are shown with a green mark, and folders are shown with an orange mark.

When a SAMPLE data file is selected

When you select a SAMPLE data file, the filename of that SAMPLE is shown (without the extension) as “Name []”.

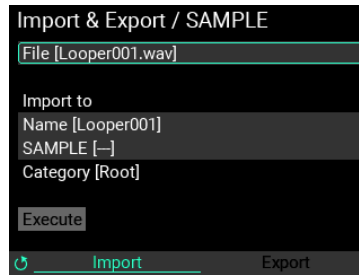

Select “Name []” and press the ENTER button to show the SAMPLE name editing screen. (→ p. 24, “Using the Name dialog box (how to change the name)”)

Move the cursor to “SAMPLE []”, and specify the write destination on the MPS-10. Press the ENTER button to show a list of SAMPLEs that are registered on the MPS-10.

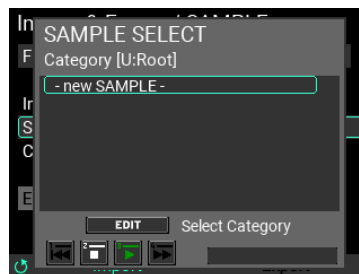

Tip: You can press the EDIT button to change the category, and you can also create new categories.

Note: Use caution when you select an existing SAMPLE, as its data will be overwritten and the data will be lost.

To create a new SAMPLE, select “- new SAMPLE -”.

Move the cursor to “Execute” and press the ENTER button. A message is shown on the page, confirming whether you want to import the data.

Press the ENTER button to execute. Press the EXIT button to cancel.

Note: If you cancel the operation while in progress, the SAMPLE being imported is discarded.

When a folder containing multiple SAMPLE data files is selected

After selecting the folder, specify the write destination on the MPS-10. When you select a folder, this only specifies the category, not the SAMPLE.

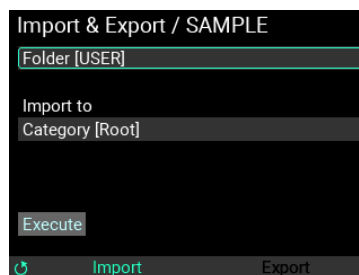

Move the cursor to “Category” and press the ENTER button to show a list of categories for the SAMPLEs that are registered on the MPS-10.

Note: A new category is created when you select “- new CATEGORY -”.

After selecting “Category”, the screen looks like this.

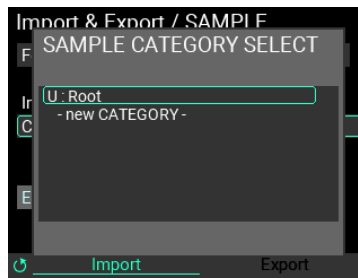

Move the cursor to “Execute” and press the ENTER button. This imports the readable SAMPLE data files within the folder as new SAMPLEs.

Note: Cancel the operation while in progress if you want to stop importing. Note that the SAMPLEs that were imported up to that point remain in internal memory.

Note: When creating a new SAMPLE, the SAMPLE name is used for the filename. Use only alphanumeric characters for the filename. (Japanese filenames cannot be used.)

How to export SAMPLEs

Here’s how to export the SAMPLE data saved in this unit to a USB flash drive.

- 1 Turn the METRONOME knob to switch from the “Import” page to the “Export” page.

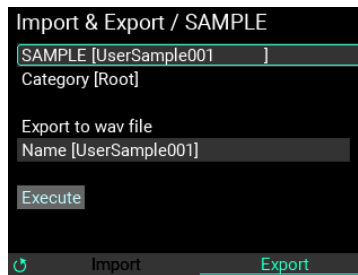

- 2 Move the cursor to “SAMPLE” and press the ENTER button. A page listing the SAMPLEs in this unit is shown.

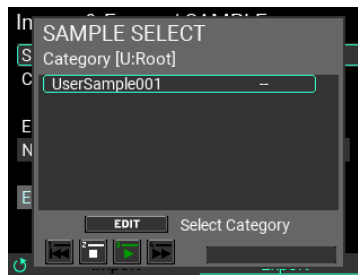

Note: You can press the EDIT button to change the category.

- 3 When you confirm a SAMPLE by pressing the ENTER button, the “Category” and “Name” are shown for the selected SAMPLE data.

- 4 Next, specify the filename of the SAMPLE to export.

Move the cursor to “Name” and press the ENTER button to show the rename page. (→ p. 24, “Using the Name dialog box (how to change the name)”)

- 5 Move the cursor to “Execute” and press the ENTER button. A message is shown on the page, confirming whether you want to export the selected SAMPLE. Press the ENTER button to execute. Press the EXIT button to cancel.



Note: If there is already a file with the same name when you press “Execute”, the message shown below appears.



To overwrite the existing data, press the ENTER button. To go back and rename the data, press the EXIT button.

Note: When you cancel the export SAMPLE operation, the export stops and the file currently being exported is deleted from the USB flash drive.

Note: To delete the data that’s saved, delete the WAV file with the name you specified in “Name,” located in the “SAMPLE” subfolder of the “MPS_10” folder on the USB flash drive.

Import & Export / LOOPER Data

“Looper data” refers to the collection of saved audio data from the four tracks, as well as the looper setup parameters.

Move the cursor to “LOOPER Data” on the Import & Export top page, and press the ENTER button to enter the Import & Export page for “LOOPER Data”.



How to import looper data

Here’s how to import all looper data into internal memory from a USB flash drive.



- 1 Move the cursor to “Folder” and press the ENTER button to show the list of “LOOPER Data” folders that are saved to the USB flash drive.

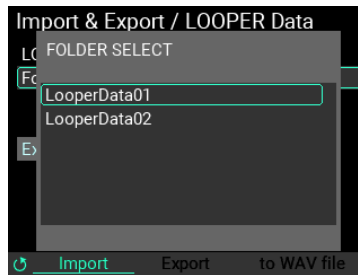

Use the VALUE knob to select the looper data that you want to import, and press the ENTER button to confirm.

- 2 Move the cursor to “Execute” and press the ENTER button. A message is shown on the page, confirming whether you want to import the selected set of looper data.



Press the ENTER button to execute. Press the EXIT button to cancel.

How to export looper data

Here’s how to save the current set of looper data to a USB flash drive.

- 1 Turn the METRONOME knob to switch from the “Import” page to the “Export” page.



Note: Move the cursor to “Name” and press the ENTER button to show the rename page. (→ p. 24, “Using the Name dialog box (how to change the name)”))

- 2 Move the cursor to “Execute” and press the ENTER button. A message is shown on the page, confirming whether you want to export the selected set of looper data. Press the ENTER button to execute. Press the EXIT button to cancel.

Note: If there is already a folder with the same name when you press “Execute”, the message shown below appears. To overwrite the existing data, press the ENTER button. To go back and rename the data, press the EXIT button.

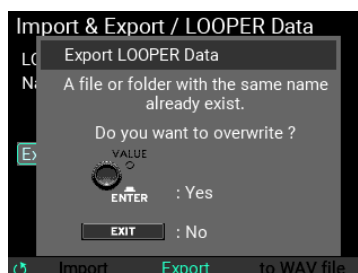

Note: To delete the data that’s saved, delete the folder with the name you specified in “Name,” located in the “LOOPER” subfolder of the “MPS_10” folder on the USB flash drive.

How to export to a WAV file

You can save the audio data that's recorded in a specified track to a USB flash drive as a WAV file.

- 1 Turn the METRONOME knob to switch to the "to WAV file" page.



- 2 Move the cursor to "LOOPER Track" and press the ENTER button, then select the track you want to export.

Note: You can't export all four tracks at the same time.

Note: Move the cursor to "Name" and press the ENTER button to show the rename page. (→ p. 24, "Using the Name dialog box (how to change the name)")

- 3 Move the cursor to "Execute" and press the ENTER button. A message is shown on the page, confirming whether you want to export the WAV file for the selected track. Press the ENTER button to execute. Press the EXIT button to cancel.



Note: If there is already a file with the same name when you press "Execute", the message shown below appears. To overwrite the existing data, press the ENTER button. To go back and rename the data, press the EXIT button.

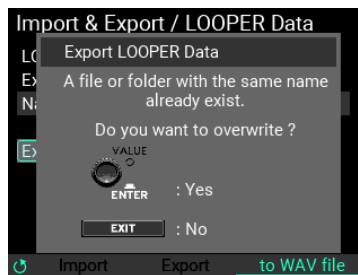

Note: To delete the data that's saved, delete the WAV file with the name you specified in "Name," located in the "SAMPLE" subfolder of the "MPS_10" folder on the USB flash drive.

Import & Export / UTILITY Data

The UTILITY data is a set of data that contains the setting parameters for the Setup, SET LIST and Function Assign screens.

Move the cursor to “UTILITY Data” on the Import & Export top page, and press the ENTER button to enter the Import & Export page for “UTILITY Data”.

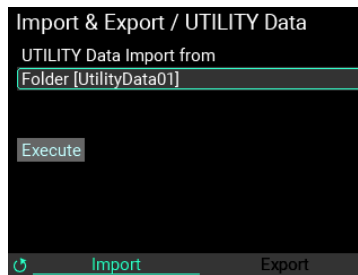

How to import the UTILITY data

Here’s how to import all UTILITY data into internal memory from a USB flash drive.

- 1 Move the cursor to “Folder” and press the ENTER button to show the list of “UTILITY Data” folders that are saved to the USB flash drive.

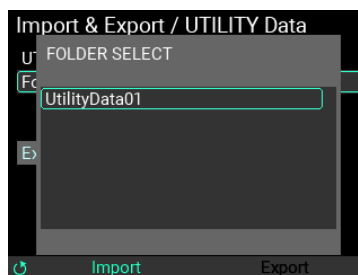

- 2 Use the VALUE knob to select the UTILITY data that you want to import, and press the ENTER button to confirm.

After that, move the cursor to “Execute” and press the ENTER button. A message is shown on the page, confirming whether you want to import the set of UTILITY data.

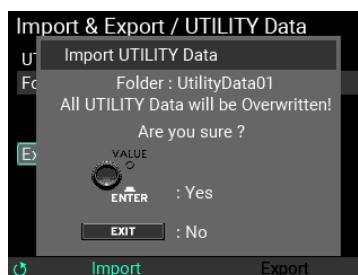

Press the ENTER button to execute. Press the EXIT button to cancel.

How to export UTILITY data

Here’s how to save the current set of UTILITY data to a USB flash drive.

- 1 Turn the METRONOME knob to switch from the “Import” page to the “Export” page.

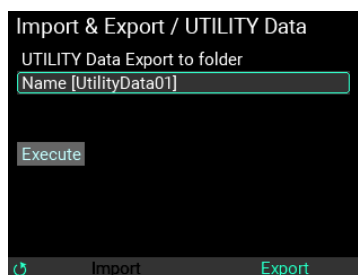

Move the cursor to “Name” and press the ENTER button to show the rename page. (→ p. 24, “Using the Name dialog box (how to change the name)”)

- 2 Move the cursor to “Execute” and press the ENTER button. A message is shown on the page, confirming whether you want to export the selected utility data. Press the ENTER button to execute. Press the EXIT button to cancel.

Note: If there is already a folder with the same name when you press “Execute”, the message shown below appears. To overwrite the existing data, press the ENTER button. To go back and rename the data, press the EXIT button.



Note: To delete the data that’s saved, delete the subfolder with the name you specified in “Name,” located in the “UTILITY” subfolder of the “MPS_10” folder.

Rename

You can change (rename) the names and category names of the KITS, INSTs and SAMPLE data that you create. However, you can’t rename the preset data.

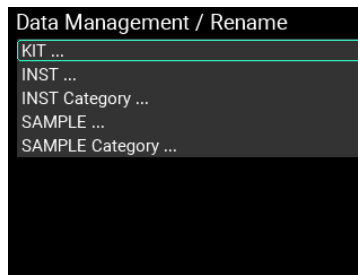

Renaming

Here’s an example of renaming, using a user KIT named “KIT 101”.

- 1 Select “KIT...” on the Data Management/Rename page, and press the ENTER button.
- 2 Select the KIT to rename.

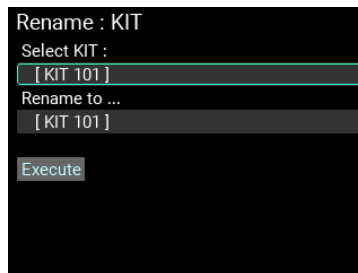

- 3 Edit the name of the KIT to rename. (→ p. 24, “Using the Name dialog box (how to change the name)”))

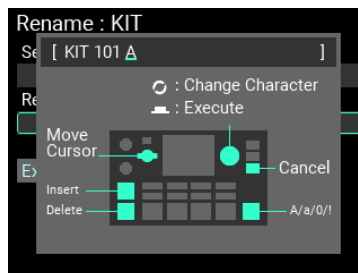

- 4 Move the cursor to “Execute” and press the ENTER button. The following confirmation message is shown.



Tip: If there is already a file or category with the same name as the one you just renamed when you press “Execute”, the message shown below appears.



If you rename the file here, the existing file is not overwritten, but a new file with the same name is registered in that category.

- 5 Press the ENTER button again to finish renaming.

Note: You can’t rename the “Root” category.

Note: To rename the INST (instrument) or SAMPLE data or categories, select “INST ...”, “INST Category ...”, “SAMPLE ...” or “SAMPLE Category ...” in step 1 above first.

Move

You can change (move) the categories to which the INST and SAMPLE data is registered. However, you can’t move the preset data.

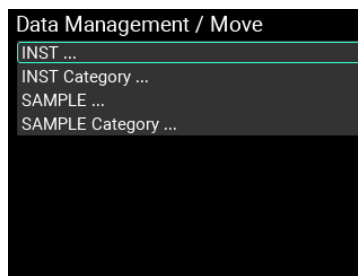

Changing the categories to which the INST and SAMPLE data are registered

In this example, we change the category to which the user INST “Instrument 001” is registered, from “Root” to “UserCategory001”.

- 1 Select “INST...” on the Data Management/Rename page, and press the ENTER button.

Tip: To move the SAMPLE data, select “SAMPLE ...” here.

2 Select the INST to move.

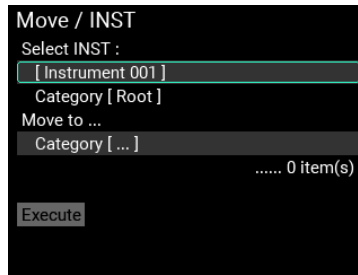

3 Select the category to which you want to move the INST.

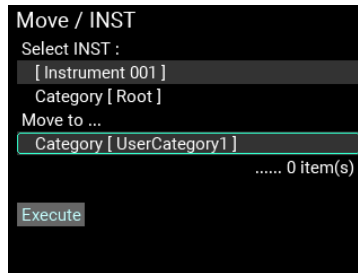

4 Move the cursor to “Execute” and press the ENTER button. The following confirmation message is shown.

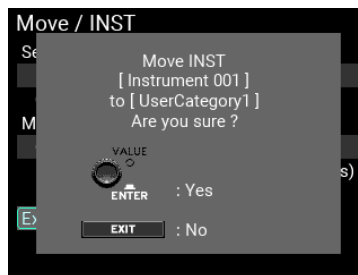

Note: If there is already data in the move destination category with the same name as the one you are moving when you press “Execute”, the message shown below appears.

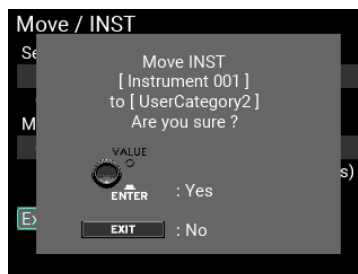

If you move the data in this state, the existing data is not overwritten, but new data with the same name is registered in that category.

5 Press the ENTER button to finish moving.

Changing the registered category for all data within a category

In this example, we move all INST data in the “Root” category to “UserCategory001”.

1 Select “INST Category ...” on the Data Management/Move page, and press the ENTER button.

Tip: To move the SAMPLE data within a category, select “SAMPLE Category ...” here.

- 2 Select the category from which you want to move the data.

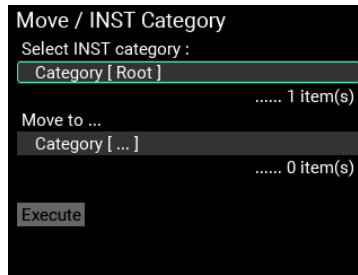

- 3 Select the category to which you want to move the data.

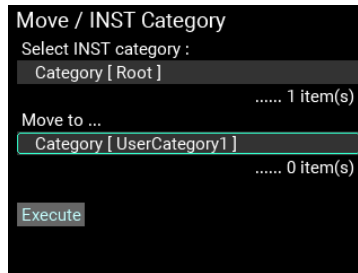

- 4 Move the cursor to “Execute” and press the ENTER button. The following confirmation message is shown.

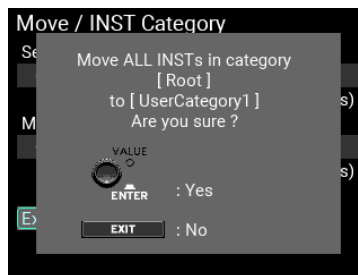

Note: If there is at least one SAMPLE data item in the move destination category with the same name, the message shown below appears.



If you move the data in this state, the existing data is not overwritten, but new data with the same name is registered in that category.

- 5 Press the ENTER button to finish editing the registered category.

Note: It may take some time if you try to move a lot of data all at once.

Delete

You can delete the INST and SAMPLE data that you've created. You can also delete the categories along with all data within those categories. However, you can't delete the preset data.

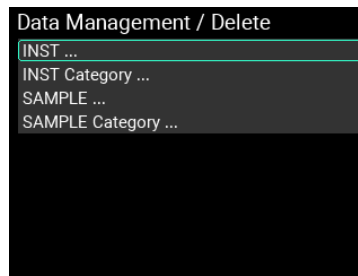

Deleting INSTs and SAMPLEs

In this example, we delete the INST called "Instrument 001", which is in the "Root" category.

- 1 Select "INST ..." on the Data Management/Delete page, and press the ENTER button.

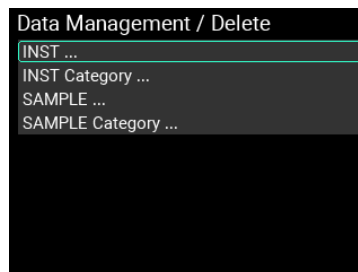

Tip: To delete the SAMPLE data, select "SAMPLE ..." here.

- 2 Select the file to delete.

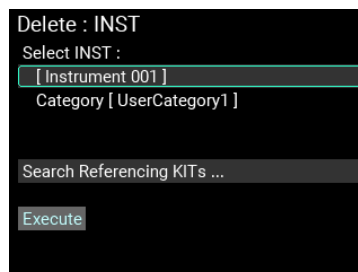

- 3 Move the cursor to "Search the Referencing KITS ..." and press the ENTER button to check the KIT or INST that's used by the file that you want to delete.



- 4 Move the cursor to “Execute” and press the ENTER button. The following confirmation message is shown.

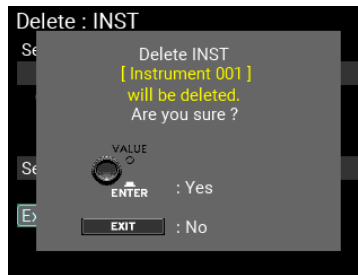

- 5 Press the ENTER button to finish deleting the file. When you delete a SAMPLE, the audio file saved in the MPS-10’s internal memory is also erased.

Note: Use caution, as you can’t recover a file once it’s been erased.

Note: When you delete an INST, [--OFF--] is assigned to the pads of the KIT that refers to that INST. Also, if you delete a SAMPLE, [--OFF--] is assigned to the block of the OSC that refers to that SAMPLE.

Deleting the categories and all the SAMPLEs/INSTs within the categories

In this example, we delete “UserCategory1” and all INST data in the category.

- 1 Select “INST Category ...” on the Data Management/Delete page, and press the ENTER button.

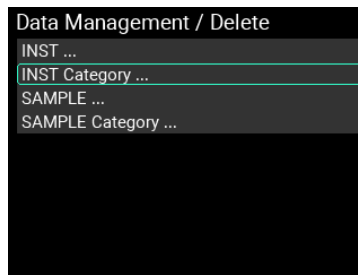

Tip: To delete the SAMPLE data within the category, select “SAMPLE Category ...” here.

- 2 Select the category to delete.

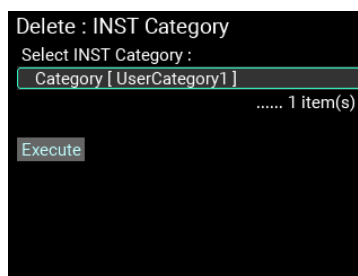

- 3 Move the cursor to “Execute” and press the ENTER button. The following confirmation message is shown.

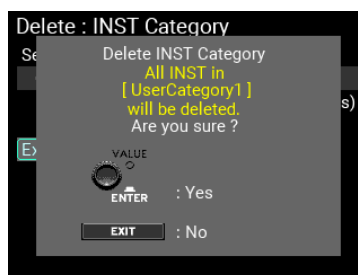

- 4 Press the ENTER button to finish deleting the category and files. When you delete a SAMPLE, the audio file saved in the MPS-10’s internal memory is also erased.

Note: Use caution, as you can’t recover a file once it’s been erased.

Note: When you delete an INST, [--OFF--] is assigned to the pads of the KIT that refers to that INST. Also, if you delete a SAMPLE, [--OFF--] is assigned to the block of the OSC that refers to that SAMPLE.

Note: When you try to delete the “Root” category, all files within the category are deleted but the “Root” category itself remains.

System

Here you can format a USB flash drive, restore the factory default settings and update the system.

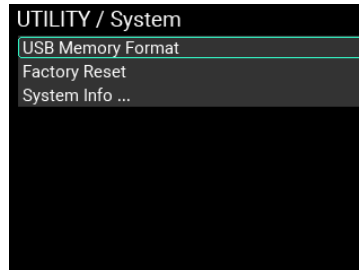

USB Memory Format

This formats (initializes) the USB flash drive.

- 1 Move the cursor to “USB Memory Format” and press the ENTER button.

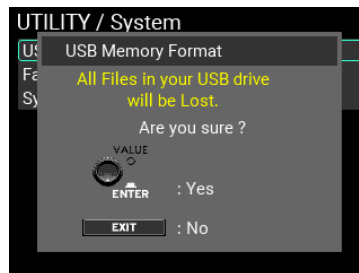

A message will display on the page to confirm the format procedure.

- 2 Press the ENTER button again to begin formatting. To cancel formatting, press the EXIT button.

Note: Make sure to format the USB flash drive on the MPS-10 before use.

Note: Formatting the USB flash drive will erase all its data. Back up any data on the flash drive that you wish to save by copying it to your computer or other device, before formatting the drive.

Factory Reset

You can restore all of the MPS-10 settings to their factory-set default state.

- 1 Move the cursor to “Factory Reset” and press the ENTER button.

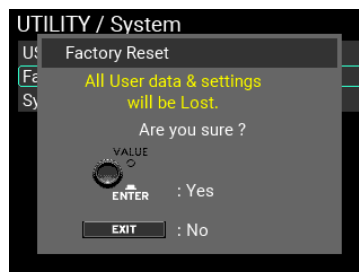

A message will display on the page to confirm the reset procedure.

- 2 Press the ENTER button again to restore the factory default settings.

To cancel the reset, press the EXIT button.

Note: This deletes any settings such as KITS, INSTs, SAMPLEs or system data as well as data you’ve recorded. The data cannot be recovered. Before you proceed, make sure that you want to erase the data and settings. Back up any data that you want to keep to a USB flash drive, such as user data, system data and so on.

System Info

Checks the system version of the MPS-10. This is also used for updating the system.

Move the cursor to “System Info” and press the ENTER button.

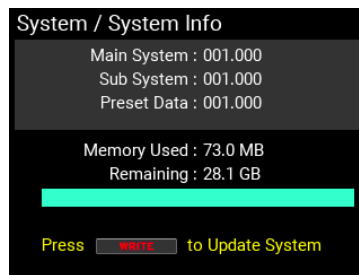

This lets you check the current system version and the internal memory available.

How to update the system

- 1 Begin by downloading the system file for updating to your computer, and copy that data to a USB flash drive.

Note: Make sure to save the system file to the root folder.

- 2 Connect the USB flash drive to the MPS-10. The System Info page appears.

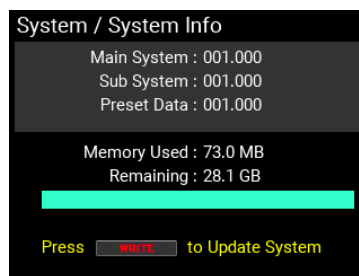

- 3 Press the WRITE button.

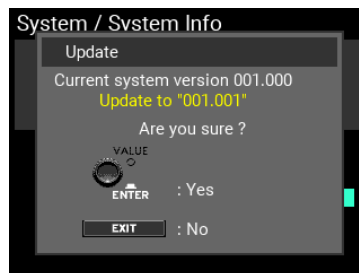

A message is shown on the page to confirm the update.

The update begins when you press the ENTER button, and a message is shown to confirm that the unit will turn off.

To cancel the update, press the EXIT button.

Note: If there is no system data for updating on the USB flash drive or if the USB flash drive is not inserted, the following message appears.

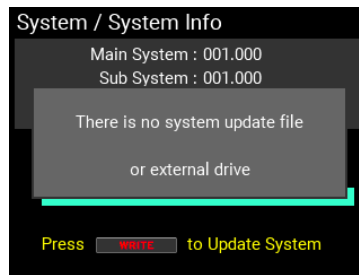

Saving the UTILITY settings

To save the UTILITY settings you've edited, you must write them.

Tip: The looper edit parameters are also UTILITY parameters, so you can save them as well by writing the utility parameters.

When you press the WRITE button on a page in UTILITY for which no message is shown, a message is shown for saving all the UTILITY settings to the MPS-10.

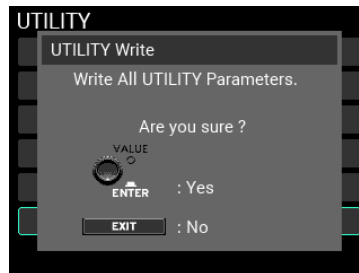

The settings you save here will be the default UTILITY settings the next time you turn on the power, so make sure to save them before turning off the power.

Tip: The data that's saved includes Setup, LOOPER, SET LIST and Function Assign.

Tip: You can save the UTILITY settings even when Memory Protect is "ON".

Appendix

Connecting to your computer

A USB cable can be used to connect this unit to a computer, which lets you use the USB MIDI and USB AUDIO functions. Also, this unit can be used with the MPS-10 dedicated editor. See the Korg website for more information on the editor.

Windows

- Supported computers

Computers running Windows 10 or later with a USB port

- Supported OS

Windows 10 (64-bit), Windows 11 (64-bit)

Macintosh

- Supported computers

Apple Macintosh computer with Apple silicon or Intel processor running macOS, with USB port

- Supported OS

macOS 10.15 or later



Not all devices that meet these operating requirements are guaranteed to work.

Folders on the USB flash drive

This explains the folders that are created on the USB flash drive when you format or save data on the MPS-10.

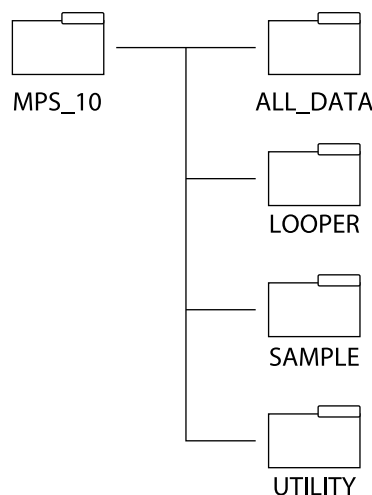

ALL_DATA: The data is saved to the folder named with the “Name” parameter in “Export All User Data”.

LOOPER: The data is saved to the folder named with the “Name” parameter in “Export Looper”.

SAMPLE: The data is saved as a WAV file, whose name is specified with the “Name” parameter in “Export SAMPLE” and “Export to WAV file”. When you’re importing a WAV/AIFF file, save the SAMPLE file in this folder.

UTILITY: The data is saved to the folder named with the “Name” parameter in “Export Utility”.

Troubleshooting

Power does not turn on

- Make sure that the AC adapter is correctly plugged into this instrument and into the AC outlet.

Power turns off abruptly

- The Auto Power Off feature automatically activates when you haven't played or operated this unit for four hours (this is the factory setting). If you don't need the Auto Power Off feature, set Auto Power Off to "Disable" in UTILITY / Setup.

No sound is heard when the pads are played

- Turn the MAIN VOL. and PHONES knobs clockwise.
- In UTILITY / Setup → Audio In & Out, check whether Sub output and output OFF have not been enabled in the Out Routing page.
- Check whether any functions have been set using the PAD FUNCTION in UTILITY.

Input/output volume is too low

- Turn the MAIN VOL. and PHONES knobs clockwise to adjust the output volume.
- Adjust the input/output volume on the Setup / Audio In & Out page.
- The PHONES output volume may seem a little low if you are listening with headphones of 80 Ω impedance or greater.

The sound doesn't stop even when the SOUND OFF button is pressed

- SOUND OFF stops the pads from sounding, but it does not stop the output of the LOOPER, IFX or MFX.
- If you're using an effect with a long reverb tail, the sound may not stop right away even though you've pressed SOUND OFF.

Can't hear the LINE IN (MIC IN) and USB Audio IN sound

- Turn the MAIN VOL. and PHONES knobs clockwise.
In UTILITY / Setup → Audio In & Out, check whether the AUX IN Select and the Gain/Level settings for the respective inputs are set correctly from the Input page.
- Check whether the AUX In and USB In for the Out Routing is not set to "SUB" or "OFF".
- When using USB Audio IN, check whether the audio output destination of the computer that's connected to this unit is set to "MPS-10".

The metronome can't be heard, even when turned on

- Turn the MAIN VOL. and PHONES knobs clockwise.
- In UTILITY / Setup → Audio In & Out, check whether the Metronome setting for Out Routing is set correctly.
- In UTILITY / METRONOME, adjust the Level setting so that you can hear the metronome.

Can't import SAMPLE files from USB flash drive

- Make sure that you've formatted the USB flash drive on this unit before you use it.
- The files that can be imported into the MPS-10 are as follows:
 - WAV files (PCM format)
 - AIF files
 - 44.1/48kHz, 16-bit
 - Maximum of 1 hour long per file
- Check whether the file is in the "MPS_10" → "SAMPLE" folder that's created when you format the storage media.
- Japanese filenames do not display correctly. Use single-byte alphanumeric characters (letters, numbers or symbols) for the filename.
- Check whether there is enough free space in internal memory to accommodate the file size of the SAMPLE you want to import.

- It may take a while to import many SAMPLEs or SAMPLEs with a large file size.
- You can store up to 10,000 SAMPLEs on this unit. You can import more new SAMPLEs by deleting unwanted SAMPLEs or overwriting existing SAMPLEs.

Can't export All User Data or SAMPLEs to the USB flash drive

- The All User Data function includes all the user data including the SAMPLEs. As a result, the file size tends to be large. Check whether there is enough free space on the USB flash drive (export destination) to accommodate the export file size.
- It may take a while to export many saved SAMPLEs or SAMPLEs with a large file size.

BPM information is not included in the imported SAMPLE data

- In Sample mode, import the sample file on the Sample page, set "SAMPLE BPM" and save.

The Looper and SET LIST settings are erased when the power is turned off

- As the Looper and SET LIST parameters are found in UTILITY, execute UTILITY Write to overwrite the values.

LCD screen or LEDs are too dark or bright

- Adjust the LCD or LED brightness from Setup / Display.

Pedals are not operating as expected

- Calibrate the pedals.

When external pads are connected to the TRIGGER IN CH A/B or C/D jack and I play two pads at the same time, I only hear sound from one pad

- The MPS-10 is configured by factory-set default to cancel out the resonance from other pads when a pad sounds.
In UTILITY / Setup → PAD Trigger, set Xtalk Cancel to "Off".

Effects are not applied even when IFX is ON

- To apply the IFX, select a pad for which effects are applied on the PAD EDIT page; and in IFX Assign, set whether IFX1 or 2 is applied.

Error messages

Error messages	Cause of error and how to solve
Cancelled	You pressed the EXIT button during an operation that could be canceled.
Store Error Import Error Export Error Setup Error	An error has occurred when writing to or reading from a file in internal memory or on a USB flash drive. If read/write errors occur frequently, use a different USB flash drive. Contact our service representative if you encounter errors after several unsuccessful tries of writing to or reading from internal memory.
Move Error	An error occurred when writing to or reading from a file in internal memory.
Delete Error	Contact our service representative if you encounter errors after several unsuccessful tries.
Data Load Error	An error has occurred when loading the parameter data used by the system. Turn the power off and on again. If the error still occurs after cycling the power, contact our service representative.
System Error	A system communication error has occurred. Turn the power off and on again. If the error still occurs after cycling the power, contact our service representative.
Memory Full	There isn't enough free space in the internal memory to execute the operation (Import SAMPLE, RECORDER, etc.). Delete any unnecessary SAMPLE data from internal memory.
No Data Exists	The track you specified when executing Export to WAV file contains no data.
No Data File Exists	There are no files present in the folder you specified with the Import SAMPLE operation that can be imported.
Invalid Data File	The system file for updating is incorrect. If the error still occurs after copying the system file again, use a different USB flash drive.
Calibration Error	An error occurred when you tried to calibrate a pedal. Try calibrating again.
Format Error	An error occurred when formatting the USB flash drive. If an error still occurs after trying this several times, use a different USB flash drive.
External Drive Full	The data file could not be created or stored, due to insufficient memory remaining on the USB flash drive. Delete any files on the USB flash drive that you do not need.
Memory Protected	The internal memory protect feature is on. Turn Memory Protect off in the Setup page of UTILITY.
Unsupported File	The SAMPLE data format is not supported for the file you specified in Import SAMPLE. Supported SAMPLE data formats are WAV or AIFF (16-bit, mono/stereo, 44.1/48 kHz, up to 60 minutes long).

Block diagram

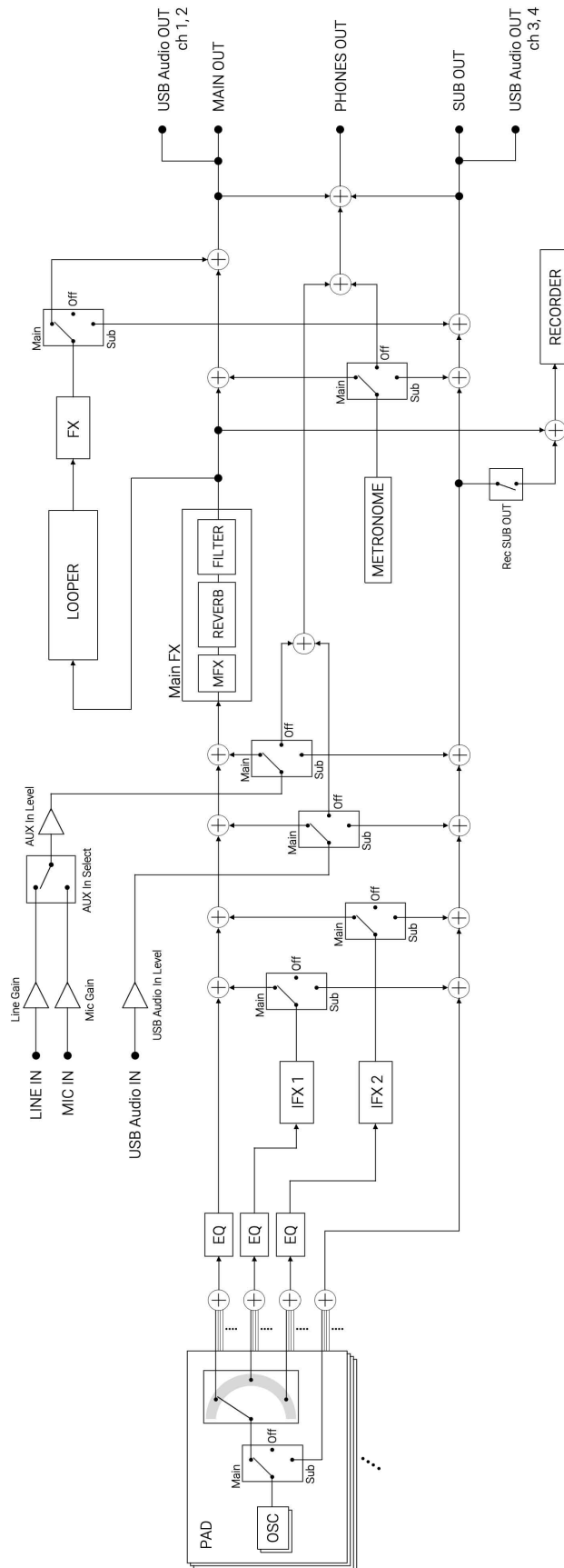

Main specifications

Maximum polyphony	48 voices
Kits	200 (including user KITS)
INST	2358
SAMPLE	3000
Effects	77
Input/output jacks and ports	<ul style="list-style-type: none"> • Headphones (6.3 mm TRS phone jack) • Audio outputs: MAIN OUT L (MONO), MAIN OUT R, SUB OUT 1, SUB OUT 2 (6.3 mm TRS phone jacks) • Audio inputs: LINE IN L/R, MIC IN (6.3 mm TRS phone jacks) • Trigger input: CH A/B, C/D (6.3 mm stereo phone jacks) • Foot pedals 1, 2 (6.3 mm TRS phone jacks) • Expression pedal (6.3 mm TRS phone jack) • MIDI OUT • USB-A (Type-A) USB standard ver. 2.0, Hi-Speed compliant (480 Mbps) • USB-B (Type-B) USB standard ver. 2.0, Hi-Speed compliant (480 Mbps)
Internal memory	32 GB (including preset data)
Playable data formats	WAV, 44.1 kHz/48 kHz, 16-bit (up to 60 minutes long)
	AIFF, 44.1 kHz/48 kHz, 16-bit (up to 60 minutes long)
Display	320 × 240 dots (backlit color LCD)
Operating temperature	0 to +40°C (avoid condensation)
Power supply	AC adapter (DC 9 V)
Dimensions (W × D × H)	424 × 264 × 75 mm/16.69" × 10.39" × 2.95"
Weight	2.3 kg/5.07 lb
Included items	AC adapter, Quick Start Guide

Specifications and appearance are subject to change without notice for improvement.

KORG INC.

4015-2 Yanokuchi, Inagi-City, Tokyo 206-0812 JAPAN

©2023 KORG INC.

www.korg.com
Published 11/2023