



# SY-1000 GUITAR SYNTHESIZER

Reference Manual



# Contents

<b>Getting Ready</b> .....	4	Turning Off the Auto Off Function.....	20	<b>FX1–FX3</b> .....	42
<b>Connecting the Equipment</b> .....	4	<b>The Internal Structure of the SY-</b>		AC RESONANCE.....	43
<b>Turning the Power On/Off ([POWER]</b>		<b>1000</b> .....	21	AUTO WAH .....	43
switch) .....	4	<b>INST (Instrument) Block</b> .....	21	CHORUS .....	43
Auto Off Function.....	4	<b>EFFECT (Effects) Block</b> .....	21	CLASSIC-VIBE.....	44
<b>Panel Descriptions</b> .....	6	<b>INST Parameters</b> .....	22	COMPRESSOR .....	44
<b>Selecting the Instrument (Guitar/</b>		<b>Availability of Functions for Each</b>		DEFRETTER.....	44
<b>Bass) to Use (MODE SETTING)</b> .....	7	<b>INST TYPE (GUITAR MODE)</b> .....	22	DEFRETTER BASS .....	45
<b>Specifying the Device Connected to</b>		<b>Availability of Functions for Each</b>		DELAY .....	45
<b>OUTPUT Jacks (OUTPUT SELECT)</b> .....	7	<b>INST TYPE (BASS MODE)</b> .....	22	FLANGER/FLANGER BASS.....	46
<b>Making Pickup Settings (GK SETTING)</b> ..	8	<b>INST TYPE</b> .....	23	FOOT VOLUME.....	46
Specifying the Pickup Type .....	8	Parameters Common to Each INST		GRAPHIC EQ.....	47
Specifying Your Guitar's (Bass's) Scale		TYPE (COMMON) .....	23	HARMONIST.....	47
Length.....	9	Parameters Common to Each INST		HUMANIZER.....	48
Specifying the Pickup Position (BASS		TYPE (ALT TUNE) .....	24	ISOLATOR .....	48
MODE Only).....	9	<b>DYNAMIC SYNTH Parameters</b> .....	25	LIMITER .....	48
Specifying the Distance from the		OSC.....	25	LO-FI.....	48
Bridge .....	10	FILTER.....	26	OCTAVE/OCTAVE BASS .....	49
Adjusting the Pickup Sensitivity.....	10	AMP .....	26	PAN.....	49
<b>Tuning the Guitar (TUNER)</b> .....	10	LFO1, LFO2.....	27	PARAMETRIC EQ .....	49
Making Tuner Settings .....	10	SEQ.....	27	PEDAL BEND .....	49
<b>Basic Operation</b> .....	11	LAYER.....	29	PHASER .....	50
<b>Display (Play Screen)</b> .....	11	<b>OSC SYNTH Parameters</b> .....	29	PITCH SHIFTER.....	50
About the Icons.....	11	OSC.....	29	REVERB .....	51
<b>Screen Operations</b> .....	12	FILTER.....	30	RING MOD .....	51
Operating Example 1 (INST Screen) ...	12	AMP .....	31	ROTARY .....	51
Operating Example 2 (INST Edit		LFO1, LFO2.....	31	SITAR SIM .....	52
Screen).....	12	<b>GR-300 (In GUITAR MODE) / ANALOG</b>		SLICER .....	52
Operating Example 3 (EFFECT Edit		<b>GR (In BASS MODE) Parameters</b> .....	32	SLOW GEAR/SLOW GEAR BASS.....	52
Screen).....	12	GR-300/ANALOG GR .....	32	SOUND HOLD .....	52
<b>Switching Patches (Tone)</b> .....	13	<b>E.GUITAR Parameters</b> .....	33	TOUCH WAH/TOUCH WAH BASS .....	53
<b>The Structure and Patches of the SY-</b>		GUITAR (In GUITAR MODE).....	33	TREMOLLO .....	53
<b>1000</b> .....	13	GUITAR (In BASS MODE).....	33	VIBRATO .....	53
Types of Bank.....	13	AMP (AMP Modeling) .....	34	WAH .....	54
Types of Patch .....	13	NS .....	35	<b>AMP (AMP Modeling)</b> .....	54
<b>Selecting a Patch</b> .....	13	EQ .....	35	TYPE.....	55
<b>Editing a Patch</b> .....	14	<b>ACOUSTIC Parameters</b> .....	36	SP TYPE .....	55
<b>Changing the INST</b> .....	14	ACOUSTIC.....	36	MICTYPE.....	55
<b>Editing the INST</b> .....	14	AMP (AMP Modeling) .....	37	<b>CHORUS</b> .....	56
Viewing All Parameters While You Edit.		NS .....	37	<b>COMPRESSOR</b> .....	57
<b>Saving the Edited INST Settings</b>		EQ .....	37	TYPE.....	57
<b>(VARIATION)</b> .....	15	<b>AC BASS Parameters</b> .....	37	<b>DISTORTION</b> .....	57
<b>Recalling a Saved INST Variation</b> .....	15	AC BASS.....	37	TYPE.....	57
<b>Editing the Effects</b> .....	16	AMP (AMP Modeling) .....	37	<b>EQ 1, EQ2</b> .....	58
Basic Operation for Effect Editing .....	16	NS .....	37	<b>MASTER DELAY</b> .....	59
Editing While Viewing All Parameters..		EQ .....	37	TYPE.....	59
Changing the Effect Order.....	16	<b>E.BASS Parameters</b> .....	38	<b>DELAY 1, DELAY 2</b> .....	60
<b>Saving the Edited Effect Settings</b>		BASS (In GUITAR MODE).....	38	<b>REVERB</b> .....	61
<b>(VARIATION)</b> .....	17	BASS (In BASS MODE) .....	38	<b>NOISE SUPPRESSOR</b> .....	62
<b>Recalling a Saved Effect Variation</b> .....	17	AMP (AMP Modeling) .....	39	<b>FOOT VOLUME 1, FOOT VOLUME 2</b> .....	62
<b>Assigning Functions to the Foot</b>		NS .....	39	<b>SEND/RETURN</b> .....	63
<b>Switches and Expression Pedal</b> .....	18	EQ .....	39	MODE.....	63
Making Assignments from the Effect		<b>VIO GUITAR Parameters</b> .....	39	<b>DIVIDER</b> .....	64
Edit Screen (Quick Assign) .....	18	GUITAR.....	39	<b>MIXER</b> .....	64
<b>Saving a Patch</b> .....	19	HARMO .....	40	<b>BALANCER 1–BALANCER 3</b> .....	65
<b>Settings for the Entire SY-1000</b>		FILTER.....	40	<b>MAIN OUT/SUB OUT</b> .....	65
<b>(System Parameters)</b> .....	20	NS .....	40	<b>MASTER</b> .....	66
<b>Settings for the SY-1000</b> .....	20	EQ .....	40	<b>NORMAL INPUT</b> .....	66
Restoring the Factory Default		<b>POLY FX Parameters</b> .....	41	<b>CONTROL ASSIGN Parameters</b> .....	67
Settings (Factory Reset) .....	20	NS .....	41	<b>CONTROL FUNCTION</b> .....	67
		<b>EFFECT Parameters</b> .....	42	FUNCTION .....	67
				MODE.....	69

PREFERENCE.....	69
ASSIGN SETTING.....	70
ASSIGN 1–ASSIGN 16.....	70
<b>Virtual Expression Pedal System</b>	
<b>(Wave Pedal) .....</b>	<b>77</b>
STRING1–STRING6, STR HiC–STR	
LowB, STRING ALL, NORMAL IN .....	77
INPUT SENS (Input Sens) .....	77
<b>PATCH MIDI.....</b>	<b>78</b>
PATCH MIDI 1–PATCH MIDI 4.....	78
<b>GUITAR TO MIDI/BASS TO MIDI .....</b>	<b>79</b>
<b>LED COLOR .....</b>	<b>80</b>
[BANK▼]/[BANK▲] switch, [CTL1]/	
[CTL2] switch, [1]–[4] switch, CUR	
NUM.....	80
PREFERENCE.....	80
<hr/>	
<b>SYSTEM Parameters.....</b>	<b>81</b>
<b>CONTROL MODE.....</b>	<b>81</b>
<b>IN/OUT SETTING .....</b>	<b>81</b>
GK SETTING .....	81
NORMAL SETTING .....	83
MAIN OUT, SUB OUT .....	83
TOTAL.....	85
USB AUDIO.....	85
<b>HARDWARE SETTING .....</b>	<b>87</b>
KNOB SETTING .....	87
ASSIGN HOLD .....	87
GROUND LIFT .....	87
OTHER .....	88
<b>PLAY OPTION.....</b>	<b>88</b>
<b>MIDI.....</b>	<b>89</b>
Operations from the SY-1000 .....	89
Operations from an External MIDI	
Device .....	89
MIDI SETTING.....	89
PROGRAM MAP BANK1–BANK4.....	90
BULK DUMP .....	90
GUITAR TO MIDI/BASS TO MIDI.....	91
<b>TUNER .....</b>	<b>91</b>
TUNER MODE.....	91
<b>FACTORY RESET .....</b>	<b>92</b>
<b>MODE SETTING.....</b>	<b>92</b>
<hr/>	
<b>Saving a Sound (WRITE) .....</b>	<b>93</b>
Saving a Patch (PATCH WRITE).....	93
Exchanging Patches (PATCH	
EXCHANGE) .....	93
Initializing Patches (PATCH	
INITIALIZE) .....	94
Inserting a Patch (PATCH INSERT).....	94
<hr/>	
<b>Connecting to a Computer.....</b>	<b>95</b>
Installing the USB Driver .....	95
Using the SY-1000 as an Audio	
Interface .....	95
<hr/>	
<b>Troubleshooting .....</b>	<b>96</b>
When Using the SY-1000 on Its Own... ..	96
When Connected to a MIDI Device or	
Computer .....	97
<hr/>	
<b>Block Diagram .....</b>	<b>98</b>
When Using a GK PATCH .....	98
When Using a NORMAL PATCH .....	99

# Getting Ready

## Connecting the Equipment

\* To prevent malfunction and equipment failure, always turn down the volume, and turn off all the units before making any connections.

### GK IN connector

Connect a guitar or bass equipped with the Roland Divided Pickup (Roland GK-3/GK-3B) or a GK-compatible guitar such as the Roland V-Guitar GC-1 to this connector.

In addition to the signal from the divided pickup, the conventional guitar signal (normal pickup) is also input to the GK IN connector.

- \* Never connect anything other than the dedicated GK cable.

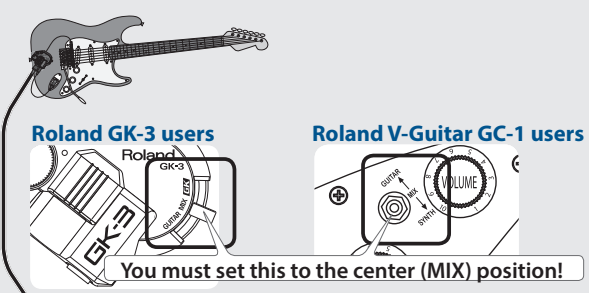

### GUITAR INPUT jack

Use this control if you're directly inputting a conventional guitar.

- \* The guitar connected to the GUITAR INPUT jack can only use a NORMAL PATCH.
- \* Use the "PATCH TYPE" parameter (p. 66) to switch to a NORMAL PATCH.



### DC IN jack

Connect the included AC adaptor here.

- \* Place the AC adaptor so the side with the indicator faces upwards. The indicator will light when you plug the AC adaptor into an AC outlet.

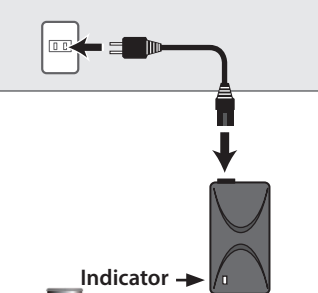



### SEND/RETURN jacks

Connect an external effect processor here.



### (USB) port

Use a commercially available USB 2.0 cable to connect this port to your computer. It can be used to transfer USB MIDI and USB audio data.

**You must install the USB driver when connecting the unit to your computer.**

Download the USB driver from the BOSS website. For details, refer to Readme.htm which is included in the download.

<https://www.boss.info/global/support/>

➔ For details on the settings, refer to "Connecting to a Computer" (p. 95).



## Turning the Power On/Off ([POWER] switch)

This turns the power on/off.

- \* Before turning the unit on/off, always be sure to turn the volume down. Even with the volume turned down, you might hear some sound when switching the unit on/off. However, this is normal and does not indicate a malfunction.

## Auto Off Function

The power to this unit will be turned off automatically after a predetermined amount of time has passed since it was last used for playing music, or its buttons or controls were operated (Auto Off function). If you do not want the power to be turned off automatically, disengage the Auto Off function.

- \* Any settings that you make in the process of editing will be lost when the power is turned off. If you have any settings that you want to keep, you should save them beforehand.
- \* To restore power, turn the power on again.

➔ For details on the settings, refer to "AUTO OFF" (p. 88).

4

**MAIN OUTPUT jack / SUB OUTPUT jack**

Connect these jacks to your guitar amp, headphones (sold separately), or to PA (LINE).

- \* Connect your headphones to the MAIN OUTPUT L/PHONES jack.
- \* If your system is mono, use only the R/MONO jack.
- \* If you're using headphones, don't connect anything to R/MONO jack.



**MIDI IN, MIDI OUT/THRU jacks**

Connect an external MIDI device here.

➔ For details, refer to "MIDI" (p. 89).

**Ground Terminal**

Connect this to an external earth or ground if necessary.



**CTL 3, 4/EXP 1, CTL 5, 6/EXP 2 jacks**

You can connect an expression pedal (EV-30, FV-500L, FV-500H, or EV-5: sold separately) or footswitch (FS-5U, FS-6, FS-7: sold separately), and use it to control various functions.

➔ For details on the settings, refer to "CONTROL ASSIGN Parameters" (p. 67).

**To use these as EXP 1, EXP 2 jacks**  
Connect an expression pedal.

**To use these as CTL 3,4 or CTL 5,6 jacks**  
Connect a footswitch.

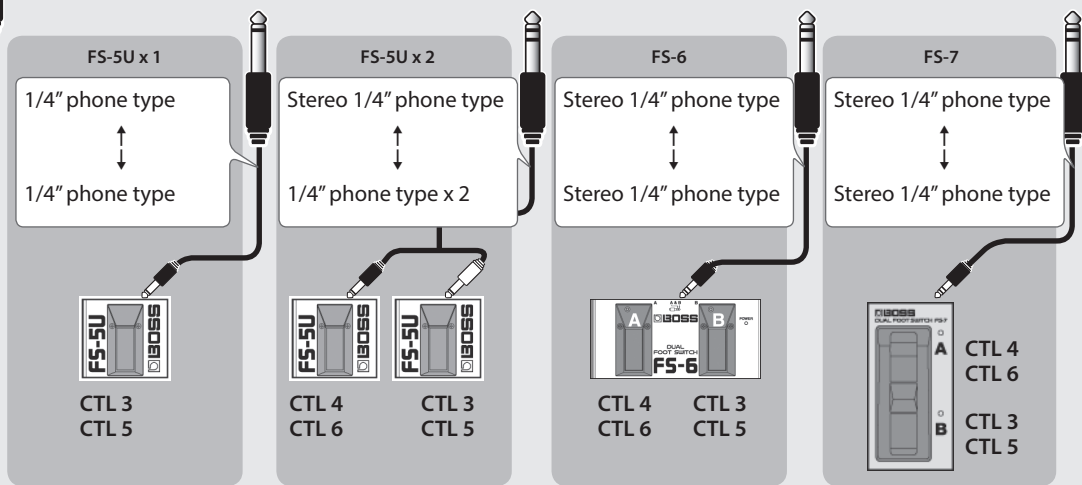
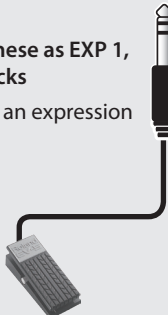

\* Use only the specified expression pedal (EV-30, FV-500L, FV-500H, or EV-5: sold separately). By connecting any other expression pedals, you risk causing malfunction and/or damage to the unit.

**MODE / POLARITY switch**

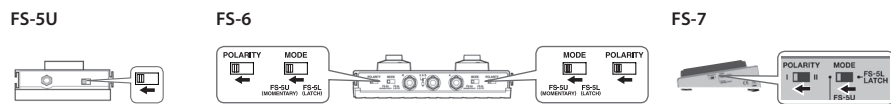

## Panel Descriptions



No.	Name	Explanation	Page
1	Display	Various information regarding the SY-1000 is indicated here.	p. 11
2	[1]–[6] knobs	Use this to select or edit the value of the parameter that's shown in the display.	p. 12
3	[OUTPUT LEVEL] knob	This adjusts the volume level for the MAIN OUTPUT jack. * Depending on how you switch the settings, you can also adjust the MAIN OUTPUT and SUB OUTPUT volumes simultaneously. [SYSTEM] button → HARDWARE SETTING → KNOB → OUTPUT LEVEL KNOB	–
4	[INST] button	Specifies the sound of the INST (sound engine).	p. 14
5	[EFFECTS] button	Specifies the effect settings and the order in which effects are connected.	p. 16
6	[CTL] button	Accesses the CTL screen, where you can assign functions to the buttons and switches.	p. 18
7	[EXIT] button	Used to return previous screens and to undo operations.	–
8	[WRITE] button	Use for storing settings in patches and executing operations.	p. 19
9	[SYSTEM] button	Used for making settings related to the SY-1000's operating	p. 20
10	[◀] [▶] (PAGE) buttons	This switches the screens displayed in the display.	p. 11
11	BANK [▼], BANK [▲] switches	Switch banks.	p. 13
12	[CTL 1] [CTL 2] switches	By default, the [CTL 1] and [CTL 2] switches control a function that's assigned by each patch.	–
13	[1]–[4] switches	Switch patches.	–

## Selecting the Instrument (Guitar/Bass) to Use (MODE SETTING)

Here you can select whether you're connecting a guitar or a bass to the SY-1000.

Choose GUITAR MODE (GUITAR) if you're using a guitar, or choose BASS MODE (BASS) if you're using a bass.

### 1. Press the [SYSTEM] button.



### 2. Use the [◀] [▶] (PAGE) buttons to access the "MODE SETTING" icon.

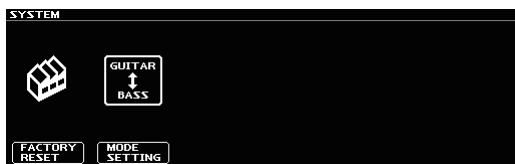

### 3. Press the [2] knob.

The message appears.

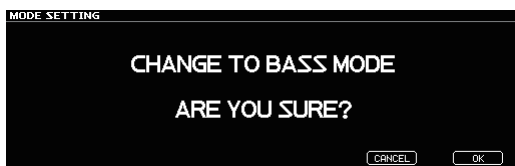

### 4. To change the mode, press the [6] knob.

If you decide to cancel, press the [5] knob. When you press the [6] knob, a message appears.



### 5. Turn the power of the SY-1000 off, then on again.

If you decide to cancel, press the [EXIT] button. Verify that the SY-1000 has started with the mode that you specified.

#### MEMO

- With the factory settings, this is set to "GUITAR."
- The SY-1000 starts with the specified mode until the next time you change the mode.
- Some parameters are displayed differently depending on the selected mode.
- Patches are saved separately for GUITAR MODE and BASS MODE.

## Specifying the Device Connected to OUTPUT Jacks (OUTPUT SELECT)

Use this procedure to set the type of device connected to the output jacks (MAIN OUTPUT, SUB OUTPUT).

This applies the optimal adjustments for the device that is connected.

### 1. Press the [SYSTEM] button.

### 2. Use the [◀] [▶] (PAGE) buttons to access the "IN/OUT SETTING" icon.



### 3. Press the [2] knob.

The IN/OUT SETTING screen appears.



### 4. Press the [3] knob or [4] knob.

The MAIN OUT screen or SUB OUT screen appears.



### 5. Press the [1] knob.

The OUTPUT SELECT screen appears.

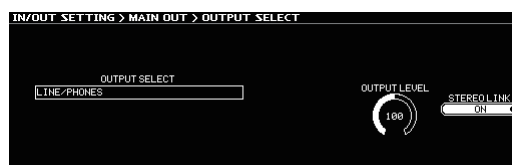

### 6. Turn the [1] knob.

Select the connected device (type of amp).

OUTPUT SELECT	Explanation
LINE/PHONES	Choose this setting if you're using headphones, or if the SY-1000 is connected to a keyboard amp, mixer, or digital recorder.
JC-120 RETURN	Choose this setting if the SY-1000 is connected to the RETURN jack of the Roland JC-120 guitar amp.
JC-120 INPUT	Choose this setting if the SY-1000 is connected to the guitar input jack of a JC-120 guitar amp.
COMBO AMP 1 RETURN	Choose this setting if the SY-1000 is connected to the RETURN jack of a combo type amp (with amp and speaker in a single unit) equipped with one speaker.

OUTPUT SELECT	Explanation
COMBO AMP 1 INPUT	Choose this setting if the SY-1000 is connected to the guitar input jack of a combo type amp (with amp and speaker in a single unit) equipped with one speaker.
COMBO AMP 2 RETURN	Choose this setting if the SY-1000 is connected to the RETURN jack of a combo type amp (with amp and speaker in a single unit) equipped with two speakers.
COMBO AMP 2 INPUT	Choose this setting if the SY-1000 is connected to the guitar input jack of a combo type amp (with amp and speaker in a single unit) equipped with two speakers.
STACK AMP RETURN	Set this when connecting to the RETURN jack on a stack-type amp.
STACK AMP INPUT	Set this when connecting to the guitar input jack on a stack-type amp.
BASS AMP WITH TWEETER	Use this setting when connecting to a tweeter-equipped bass amp.
BASS AMP NO TWEETER	Use this setting when connecting to a bass amp that has no tweeter. The high-frequency range is adjusted.

**7. Press the [EXIT] button.**

You return to the Play screen.

## Making Pickup Settings (GK SETTING)

Make settings for the divided pickup in order to ensure that you'll always be playing the SY-1000 in the optimal state.

The SY-1000 can save ten types of these settings (GK SETTING). Here we explain the example of saving pickup settings in SETTING: [1].

**MEMO**

The GK SETTING is saved even when the power is turned off. You don't need to make this setting again each time you perform.

1. Press the [SYSTEM] button.
2. Use the [◀] [▶] (PAGE) buttons to access the "IN/OUT SETTING" icon.



**3. Press the [2] knob.**

The IN/OUT SETTING screen appears.



**4. Press the [1] knob.**

The GK SETTING screen appears.



**5. Turn the [1] knob to select SETTING: [1].**

The pickup settings will be saved in SETTING: [1].

**MEMO**

Pickup settings are automatically saved in the number (SETTING: [1]–[10]) that you selected in step 5.

## Specifying the Pickup Type

Choose the type of pickup that's installed on your guitar (bass).

6. If using GUITAR MODE, turn the [5] knob.  
If using BASS MODE, turn the [4] knob.

GK PU TYPE (GUITAR MODE)	Explanation	
GK-3	Choose this if you're using a Roland GK-3.	
GK-2A	Choose this if you're using a Roland GK-2A, or if you're using a (commercially available) guitar with a built-in divided pickup.	
GC-1	Choose this if you're using a Roland V-Guitar GC-1.	
PIEZO	Piezo Pickup	(flat response)
PIEZO F		Fishman
PIEZO G		Graph Tech
PIEZO L		L.R. Baggs
PIEZO R		RMC

GK PU TYPE (BASS MODE)	Explanation	
GK-3B	Choose this if you're using a GK-3B.	
GK-2B	Choose this if you're using a Roland GK-2B, or if you're using a (commercially available) bass with a built-in divided pickup.	
PIEZO	Piezo Pickup	(flat response)
PIEZO G		Graph Tech
PIEZO R		RMC

**MEMO**

- A piezo pickup is a type of pickup that is mounted on the bridge of the guitar, and uses a piezoelectric element to detect the vibrations of the strings.
- If you don't know the type of your piezo pickup, try selecting different choices while you play your guitar, and choose the setting that produces the most natural sound.
- If you've chosen piezo type, you'll be able to make further adjustments to the tone quality of the high range and low range.

## Specifying Your Guitar's (Bass's) Scale Length

Specify your guitar's (bass's) scale length (the distance from the bridge to the nut).

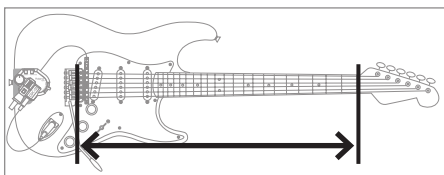

Guitar

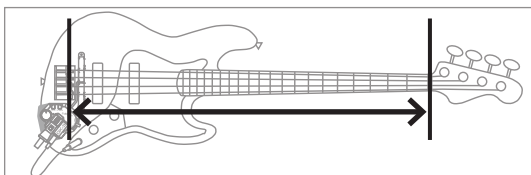

Bass

### 7. If using GUITAR MODE, turn the [6] knob. If using BASS MODE, turn the [5] knob.

Specify the length that is correct for your guitar (bass).

If you're using GUITAR MODE, choose "ST (648mm)" for a standard Stratocaster type, or choose "LP (628mm)" for a Les Paul type.

If you're using BASS MODE, For a standard Jazz Bass type or Precision Bass type, choose "LONG JB/PB (864 mm)."

**MEMO**

This parameter is not shown if GK PU TYPE is set to "Roland V-Guitar GC-1."

## Specifying the Pickup Position (BASS MODE Only)

Specify the position of the divided pickup that's installed on your bass.

**MEMO**

If you've installed a divided pickup on your guitar, proceed to step 9 "Specifying the Distance from the Bridge" (p. 10) (this step is not needed).

### 8. Turn the [6] knob

Specify the GK PU POSITION according to the position of the divided pickup that's installed.

For a 4-string bass

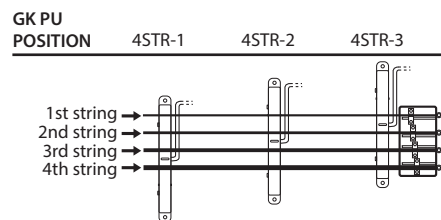

For a 5-string bass

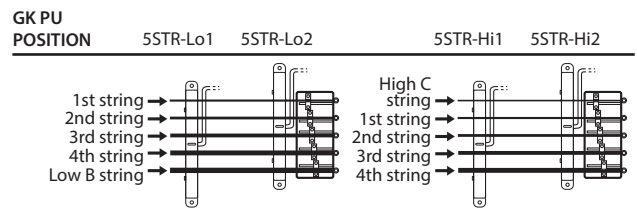

For a 6-string bass

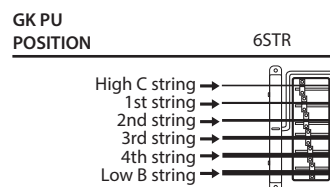

## Specifying the Distance from the Bridge

For each string, specify the distance from the bridge to the center of the pickup.

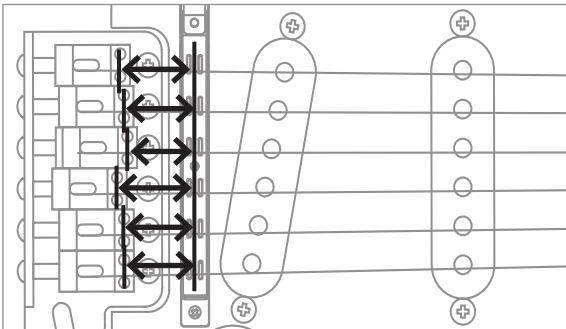

9. Use the [◀] [▶] (PAGE) buttons to access the DISTANCE screen.



10. Turn the [1]–[6] knobs.

Specify the distance from the bridge to the center of the pickup.

**MEMO**

This setting is not needed if GK PU TYPE is “Roland V-Guitar GC-1” or if you selected a piezo type pickup.

## Adjusting the Pickup Sensitivity

The volume will differ if the distances between each string and the divided pickup are different. Specify the sensitivity of the pickup to compensate for this volume difference.

11. Use the [◀] [▶] (PAGE) buttons to access the SENS screen.

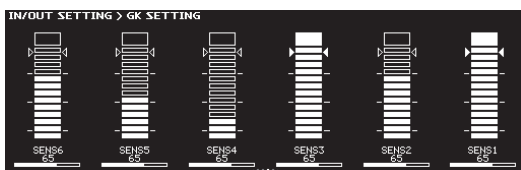

12. While playing the strings strongly, turn the [1]–[6] knobs so that the level meters reach the triangular marks.

**MEMO**

Depending on the guitar (bass) you’re using, the level meter might reach full-scale even if the sensitivity is at minimum. If this is the case, adjust the distance between the divided pickup and the string so it’s somewhat greater than the recommendation.

## Tuning the Guitar (TUNER)

Tune the guitar (bass).

The SY-1000 is equipped with a conventional monophonic tuner which lets you tune your instrument one string at a time (SINGLE MODE), and a polyphonic tuner which lets you play and tune all of your open strings simultaneously (MULTI MODE).

1. Press the BANK [▼] switch and BANK [▲] switch simultaneously.

The TUNER screen appears.

2. Use the [◀] [▶] (PAGE) buttons to select the tuner mode.

TUNER MODE	Explanation
MULTI MODE	You can play and tune six strings simultaneously. * Setting available with GK PATCH.
SINGLE MODE	You can play one individual string to tune that string.

3. Play an open string, and tune it so that only the center indicator in the screen is lit.

## Making Tuner Settings

These settings specify how the tuner operates.

Parameter	Value	Explanation
PITCH	435–445Hz (default: 440Hz)	Specifies the reference pitch.
OUTPUT	MUTE	Sound will not be output while tuning.
	BYPASS	While tuning, the sound from the GK IN connector/GUITAR INPUT jack will be output without change. All INSTs and effects will be off.
	THRU	Allows you to tune while hearing the current INST and effect sound. * Only for SINGLE MODE.

# Basic Operation

Here we explain how you can use the buttons and knobs to operate the SY-1000, and how to switch screens.

## Display (Play Screen)

The screen that appears after you start the SY-1000 is called the “play screen.”

### Screen 1

This screen shows the bank number and patch number in especially large characters.

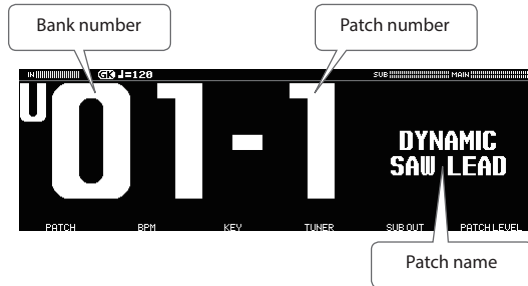

### Screen 2

This screen shows the bank number, patch number, and patch name.

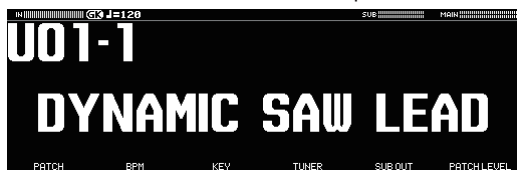

### Screen 3

This screen shows the functions that are assigned to the pedal switches of the unit.

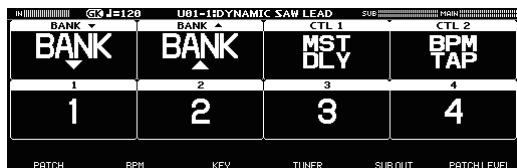

### Screen 4

This screen shows how the INST and effects are connected (CHAIN).

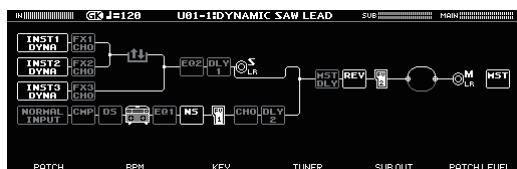

## About the Icons

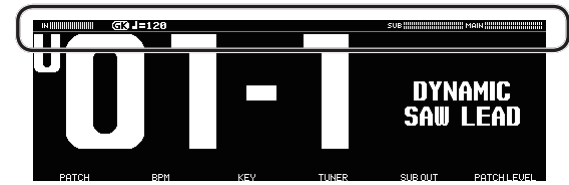

Icon	Explanations
	Indicates the input level of the GK IN connector. * When using a NORMAL PATCH (p. 13), this indicates the level of the guitar signal.
	Indicates the output level of the MAIN OUTPUT jacks and SUB OUTPUT jacks.
	Indicates the input level of the RETURN jack. * Shown in the EFFECTS edit screen.
	Indicates the output level of the SEND jack. * Shown in the EFFECTS edit screen.
	Indicates the output level of the selected effect block. * Shown in the EFFECTS edit screen.
	Indicates BALANCER1–3 and MIXER BALANCE. * Shown in the EFFECTS edit screen.
	Indicates the BPM.
	Blinks in time with the BPM.
	Shown when a GK PATCH (p. 13) is selected. When using a NORMAL PATCH (p. 13), this icon goes dark.
	When the screen contains multiple pages, this indicates the position of the current page. Indicates the page to which you navigate using the [◀] [▶] (PAGE) buttons (edit screen).

## Screen Operations

In the play screen, you can turn or press the [1]–[6] knobs to adjust the parameters that are shown in the lower part of the display.

### Operating Example 1 (INST Screen)

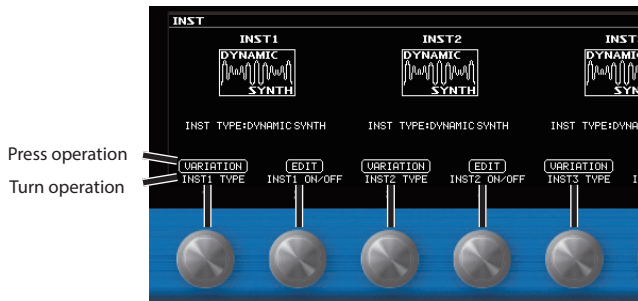

Operation	Explanation
Turn the [1] knob	Changes the INST TYPE of INST1.
Press the [1] knob	Accesses a screen where you can switch the INST TYPE variation of INST1.
Turn the [2] knob	Turns INST1 on/off. When off, the icon is shown in gray.
Press the [2] knob	Accesses the edit screen for INST1.

**MEMO**

As for INST1, you can operate INST2 with the [3] knob and [4] knob, and operate INST3 with the [5] knob and [6] knob.

### Operating Example 2 (INST Edit Screen)

Use the [6] knob to select

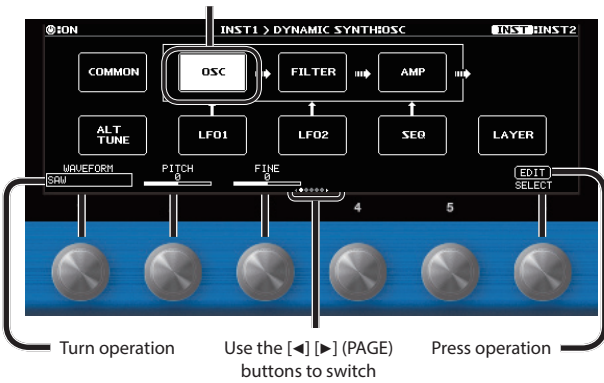

Operation	Explanation
Turn the [1]–[5] knobs	Changes the value of the setting for the parameter
Turn the [6] knob	Selects the block to edit.
Press the [6] knob	Shows a list with all parameters of the selected block.
Press the [◀] [▶] (PAGE) buttons	Switches the parameters to show.

### Operating Example 3 (EFFECT Edit Screen)

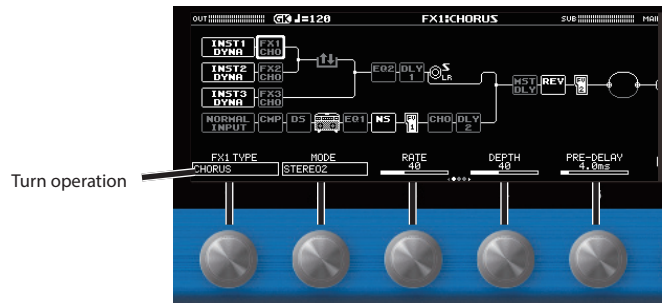

Operation	Explanation
Turn the [1]–[5] knobs	Changes the value of the setting for the parameter
Turn the [6] knob	Selects the block to edit.
Press the [6] knob	Turns the selected block on/off.
Long-press the [6] knob	Shows a list with all parameters of the selected block.
Turn the [6] knob while pressing it	Changes the position of the selected block.

**MEMO**

To change a value in larger steps, turn a [1]–[5] knob while pressing it.

# Switching Patches (Tone)

## The Structure and Patches of the SY-1000

The SY-1000 consists of three sound engines (the INST blocks) and effects whose connections you are free to change (the FX block).

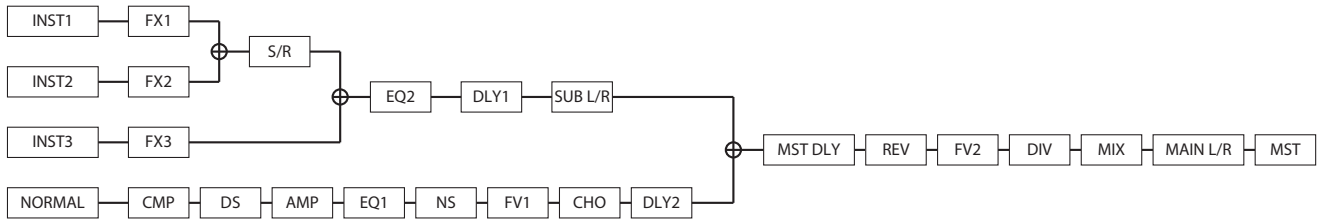

The INST settings together with the combination of effects are collectively called a “patch.”

A set of four patches is called a “bank.”

Patches are managed by their bank (1–50) and number (1–4); the SY-1000 can store 200 patches.

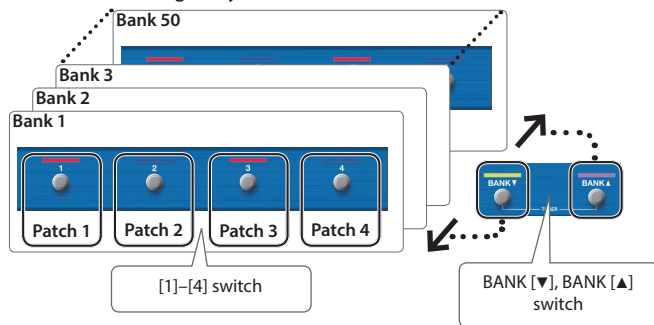

## Types of Bank

The SY-1000 has two types of bank.

Types of bank	Explanation
Preset bank (P01–P50)	Cannot be overwritten, however, you can write a preset patch into the User bank, modify the settings to your needs and store your modified version in the User bank.
User bank (U01–U50)	Can be overwritten.

## Types of Patch

The SY-1000 has two types of patch.

Types of patch	Explanation
GK PATCH	Patches for a guitar (bass) that uses a divided pickup. If these patches are selected, the display shows the GK icon
NORMAL PATCH	Patches for a conventional guitar (bass) that is connected to the GUITAR INPUT. These can be used even if you don't have a divided pickup. You can also use these patches with the conventional guitar (bass) signal (normal pickup) that is routed through the divided pickup. If you're using NORMAL PATCH, the GK icon goes dark. * DYNAMIC SYNTH is the only INST TYPE that can be selected for a NORMAL PATCH. * Use the “PATCH TYPE” (p. 66) parameter to switch to a NORMAL PATCH.

## Selecting a Patch

When you switch patches, the tonal character changes.

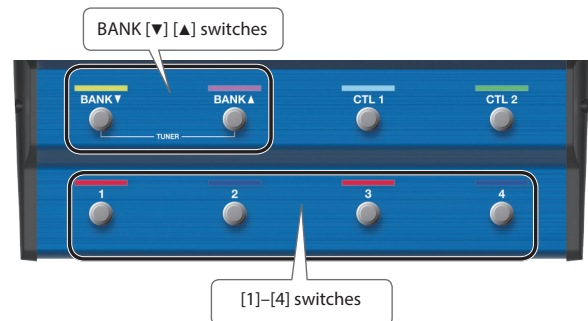

1. Use the BANK [▼] [▲] switches to select a bank.
2. Use the [1]–[4] switches to select a patch within the selected bank.

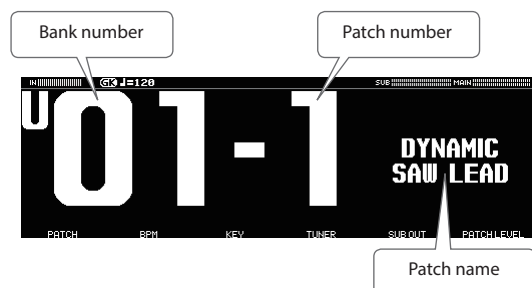

### MEMO

You can also change patches by turning [1] knob below the display.

# Editing a Patch

Here's how to create a patch by editing the parameters of the INST blocks and the effect block, and combining them.

## Changing the INST

### 1. Press the [INST] button.

The INST screen appears.



The INST screen shows the INST TYPE for INST1–INST3.

### 2. Turn the [1]–[6] knobs.

Operation	Explanation
Turn the [1] knob	Changes the INST TYPE of INST1.
Press the [1] knob	Accesses a screen where you can switch the INST TYPE variation of INST1.
Turn the [2] knob	Turns INST1 on/off. * When off, the icon is shown in gray.
Press the [2] knob	Accesses the edit screen for INST1.

#### MEMO

As for INST1, you can operate INST2 with the [3] knob and [4] knob, and operate INST3 with the [5] knob and [6] knob.

## Editing the INST

You can edit each INST in detail.

Here we explain using the example of the DYNAMIC SYNTH screen of INST1.

### 1. In the INST screen, press the [2] knob.

The INST1 screen appears.

\* The screen differs depending on the INST TYPE.

### 2. Turn the [6] knob to select the block that you want to edit.

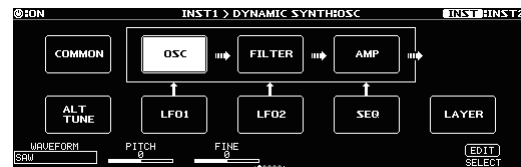

The selected block is shown in white.

### 3. Turn the [1]–[5] knobs to edit the setting of the parameter.

#### MEMO

- To change a value in larger steps, turn a knob while pressing it.
- You can use the [◀] [▶] (PAGE) buttons to switch between the parameters.
- The number of parameters and pages differ depending on the block you edit.
- In the edit screen, you can press the [INST] button to switch to the edit screen of another INST.

## Viewing All Parameters While You Edit

You can also edit while viewing a list of all parameters for the selected block.

### 1. In the edit screen, press the [6] knob.

Shows a list with all parameters of the selected block.



### 2. Turn the [1]–[6] knobs to edit the setting of the parameter.

#### MEMO

You can use the [◀] [▶] (PAGE) buttons to switch between the parameters.

## Saving the Edited INST Settings (VARIATION)

Your preferred settings for each instrument can be saved as a "VARIATION." Since a variation can also be used from another patch, it is convenient for sound design.

Here we explain using the example of the DYNAMIC SYNTH screen of INST1.

### 1. In the INST screen, press the [1] knob.

The VARIATION screen appears.

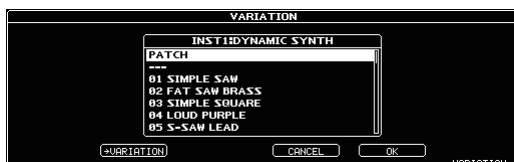

### MEMO

From the INST edit screen, you can also access the variation screen using the following methods.

#### 1. In the edit screen, select the "COMMON" block.



#### 2. Use the [▶] (PAGE) button to move to the last page.

#### 3. Press the [5] knob.

### 2. Press the [2] knob.

The VARIATION WRITE screen appears.



### 3. Turn the [1] knob to select the save-destination number.

### 4. Use the [3]–[6] knobs to specify the variation name.

### 5. Press the [WRITE] button.

The variation is saved.

To cancel this procedure, press the [4] knob.

## Recalling a Saved INST Variation

### 1. In the INST screen, press any one of the knobs [1] (INST1), [3] (INST2), or [5] (INST3).

The VARIATION screen appears.

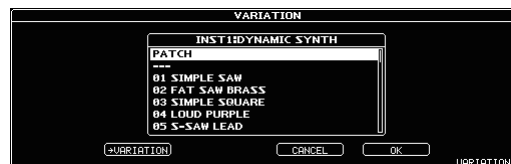

### 2. Turn the [6] knob to select a variation.

You can also audition the sound while selecting a variation.

### 3. Press the [5] knob to recall the selected variation.

## Editing the Effects

You can edit the effect settings, and change the order of blocks such as output and send/return (the effect chain).

### Basic Operation for Effect Editing

#### 1. Press the [EFFECTS] button.

The edit screen (effect chain) appears.

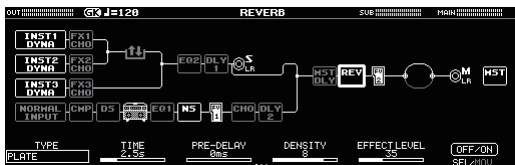

#### 2. Turn the [6] knob to select the block that you want to edit.

The selected block is enclosed by a thick frame.



\* By pressing the [6] knob you can turn the selected effect on/off. Effects that are off are shown in gray. When the effect is turned on, it is shown in white.

Off      On



#### 3. Use knobs [1]–[5] to adjust the parameters that are shown below the screen.

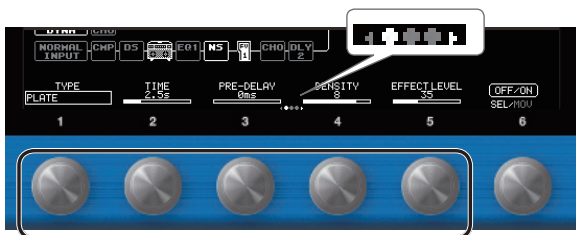

Use the [◀] [▶] (PAGE) buttons to switch between the parameters that you want to edit. The current page is indicated in the lower center of the screen.

- \* To change a value in larger steps, turn a knob while pressing it.
- \* The number of parameters and pages differ depending on the effect.

## Editing While Viewing All Parameters

You can also edit while viewing a list of all parameters for the selected block.

#### 1. In the edit screen, long-press the [6] knob.

Shows a list with all parameters of the selected block.

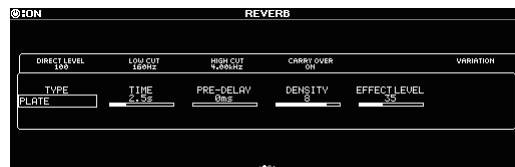

#### 2. Turn the [1]–[6] knobs to edit the parameter settings.

#### MEMO

You can use the [◀] [▶] (PAGE) buttons to switch between the parameters.

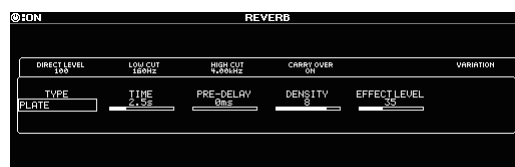

↑ Use the [◀] [▶] (PAGE) buttons to switch

## Changing the Effect Order

By moving blocks such as effects, output, and send/return, you can freely change the order in which the effects are placed, or arrange them in parallel.

#### MEMO

- You can change the order of the INST1–3 blocks and the NORMAL block.
- The MST (MASTER) block cannot be moved.

#### 1. Press the [EFFECTS] button.

The effect chain is shown.

#### 2. Use the [6] knob to select the block that you want to move.

#### 3. While pressing the [6] knob, turn it left or right.

The selected block moves left or right.

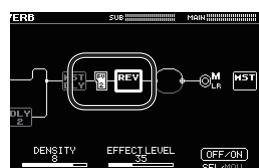
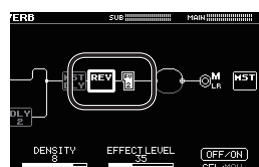

## Saving the Edited Effect Settings (VARIATION)

Your preferred settings for each effect can be saved as a “VARIATION.” Since a variation can also be used from another patch, it is convenient for sound design.

1. Press the [EFFECTS] button.
2. Use the [6] knob to choose the effect you’re going to edit.
3. Use the [◀] [▶] (PAGE) buttons to move to the last page.

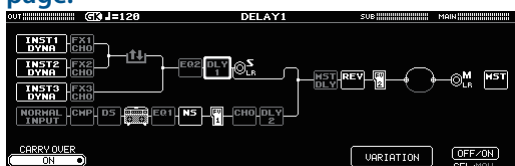

4. Press the [5] knob.

The VARIATION screen appears.



5. Press the [2] knob.

The VARIATION WRITE screen appears.



6. Turn the [1] knob to select the save-destination number.
7. Use knobs [3]–[6] to name the VARIATION.
8. Press the [WRITE] button.

The variation is saved.

To cancel this procedure, press the [4] knob.

## Recalling a Saved Effect Variation

1. Press the [EFFECTS] button.
2. Use the [6] knob to choose the effect you’re going to edit.
3. Use the [◀] [▶] (PAGE) buttons to move to the last page.

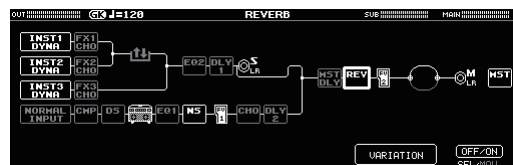

4. Press the [5] knob.

The VARIATION screen appears.

5. Turn the [6] knob to select a variation.

You can also audition the sound while selecting a variation.

6. Press the [5] knob to recall the selected variation.

## Assigning Functions to the Foot Switches and Expression Pedal

A variety of functions can be assigned to each of the top panel footswitches, and expression pedals or footswitches that are connected to the rear panel CTL3, 4/EXP1 jack and CTL5, 6/EXP2 jack (p. 5).

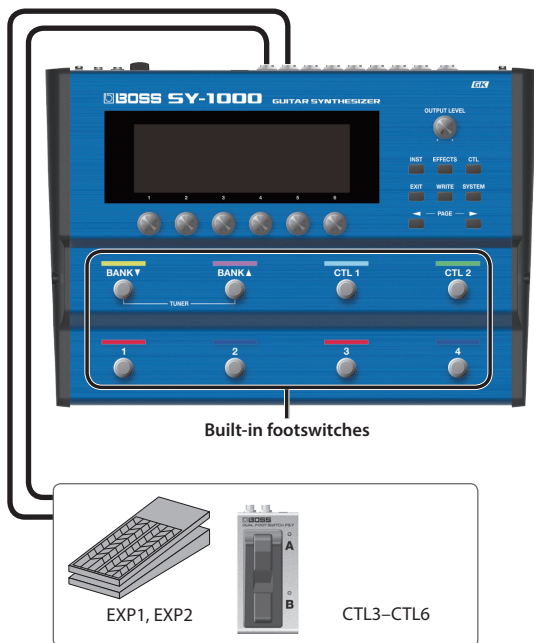

### 1. Press the [CTL] button.

The CONTROL/ASSIGN screen appears.



### 2. Press the [1] knob.

The CONTROL FUNCTION screen appears.

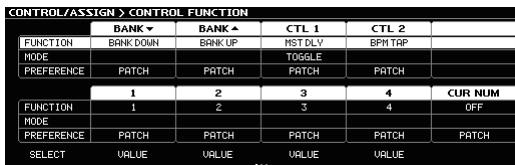

### 3. Turn the [1] knob to select the item that you want to set.

Turning the knob will move the selected item vertically.

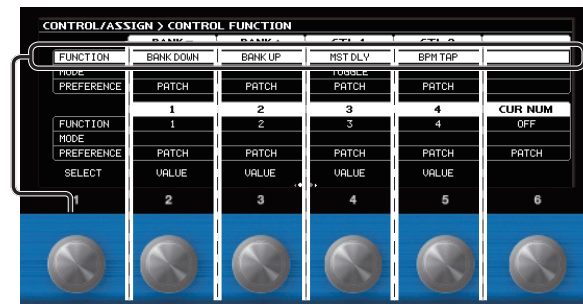

The settings of the selected item can now be edited.

### 4. Turn knobs [2]–[6] to edit the value of the item selected for each switch.

#### MEMO

- You can use the [◀] [▶] (PAGE) buttons to switch between the parameters.
- The footswitch and expression pedal functions must be specified for each patch; however, if you set PREFERENCE to SYSTEM, all patches will use those functions in common.

## Making Assignments from the Effect Edit Screen (Quick Assign)

In the effect edit screen (p. 16), you can select an effect parameter and assign that parameter to the switch of your choice.

### 1. Press the [EFFECTS] button.

### 2. Turn the [6] knob to select the block that you want to edit.

### 3. Long-press the [1]–[5] knobs for the parameter that you want to assign.



The ASSIGN MATRIX screen appears.

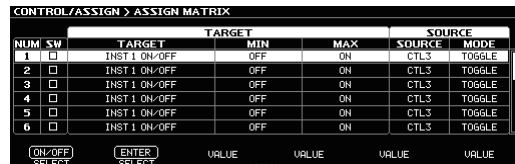

\* You can also access the ASSIGN MATRIX screen in the same way from the all-parameter list screen (p. 14). You can also access it by selecting the [CTL] button → "ASSIGN SETTING."

### 4. Press the [1] knob to turn the SW on.

### 5. Turn knobs [2]–[6] to edit parameters.

If necessary, use the [◀] [▶] (PAGE) buttons to switch between pages of settings.

Use SOURCE to specify the pedal or MIDI message that you will operate.

# Saving a Patch

The INST settings and the combination of effects can be saved in a patch, and recalled at any time.

If you select a different patch or turn off the power after editing the settings, edited settings will be lost. If you want to keep the data, you must save it.

## 1. Press the [WRITE] button.

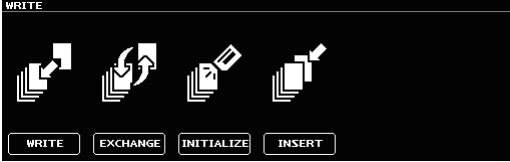

## 2. Press the [1] knob to select "WRITE" (PATCH WRITE).



## 3. Use the [1] knob to select the save-destination (U01-1–U50-4).

You can use knobs [3]–[6] to edit the name.

### Editing a name

To edit the patch name, use the [6] knob to move the cursor and use the [5] knob to change the character.

Operation	Explanation
Turn the [3] knob	Selects the type of characters
Press the [3] knob	Delete one character (delete)
Turn the [4] knob	Switch uppercase/lowercase
Press the [4] knob	Insert one space (insert)
Turn the [5] knob	Changes the character
Turn the [6] knob	Moves the cursor

## 4. Press the [WRITE] button.

The patch is written.

To cancel this procedure, press the [4] knob.

# Settings for the Entire SY-1000 (System Parameters)

## Settings for the SY-1000

Here you can make settings that are common to the entire SY-1000 (system parameters).

For details on each parameter, refer to "SYSTEM Parameters" (p. 81).1

### 1. Press the [SYSTEM] button.



#### MEMO

You can use the [◀] [▶] (PAGE) buttons to see additional items.

### 2. Press a [1]–[6] knob to select the item that you want to edit.

A sub-menu appears.



### 3. Once again press a [1]–[6] knob to select the item that you want to edit.

### 4. Use knobs [1]–[6] to select parameters or edit the values.

#### MEMO

The method of selecting parameters and editing their value will differ depending on the item.

## Restoring the Factory Default Settings (Factory Reset)

Restoring the SY-1000's settings to their original factory default settings is referred to as "Factory Reset."

Not only can you return all of the settings to the values in effect when the SY-1000 was shipped from the factory, you can also specify the items to be reset.

\* When you execute "Factory Reset," the settings you made will be lost. Save the data you need to your computer using the dedicated software.

### 1. Press the [SYSTEM] button.

### 2. Use the [◀] [▶] (PAGE) buttons to select "FACTORY RESET."



### 3. Choose the type of settings to be restored to the factory default settings with knobs [1] and [6].

Knob	Explanation
[1]	Specifies FROM.
[6]	Specifies TO.

Value	Explanation
SYSTEM	System parameter settings
U01-1-U50-4	Settings for Patch Numbers U01-1-U50-4
VARIATION	Settings for VARIATION

### 4. Press the [WRITE] button.

Press the [6] knob to execute the factory reset.

To cancel factory reset, press the [5] knob.

Once the Factory Reset is complete, you are returned to the Play screen.

## Turning Off the Auto Off Function

The SY-1000 can turn off its power automatically. The power will turn off automatically when 10 hours have passed since you last played or operated the unit. The display will show a message approximately 15 minutes before the power turns off.

With the factory settings, this function is turned "ON" (power-off in 10 hours). If you want to have the power remain on all the time, turn it "OFF."

### 1. Press the [SYSTEM] button.

### 2. Choose "HARDWARE SETTING" → "OTHER."

### 3. Use the [1] knob to select "OFF."

### 4. Press the [EXIT] button a number of times to return to the play screen.

# The Internal Structure of the SY-1000

## INST (Instrument) Block

This is the sound engine section that generates sound based on the performance data from the divided pickup and the audio input from the guitar (bass).

This can produce a variety of tones, synthesizers such as DYNAMIC SYNTH and the POLY FX which can apply effects independently to each string. The SY-1000 lets you freely specify and combine three INST blocks.

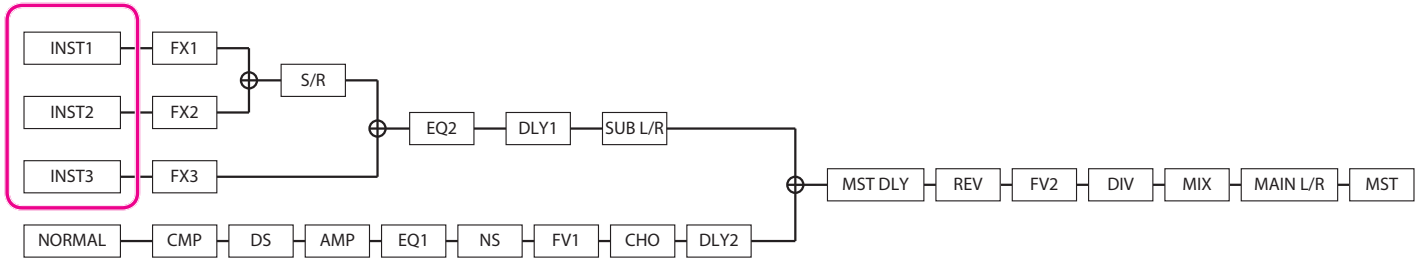

## EFFECT (Effects) Block

The SY-1000 is equipped with high-quality effects.

You can change the order in which the effects are connected.

You are also free to select the signals that are output from the MAIN OUTPUT jacks and the SUB OUTPUT jacks.

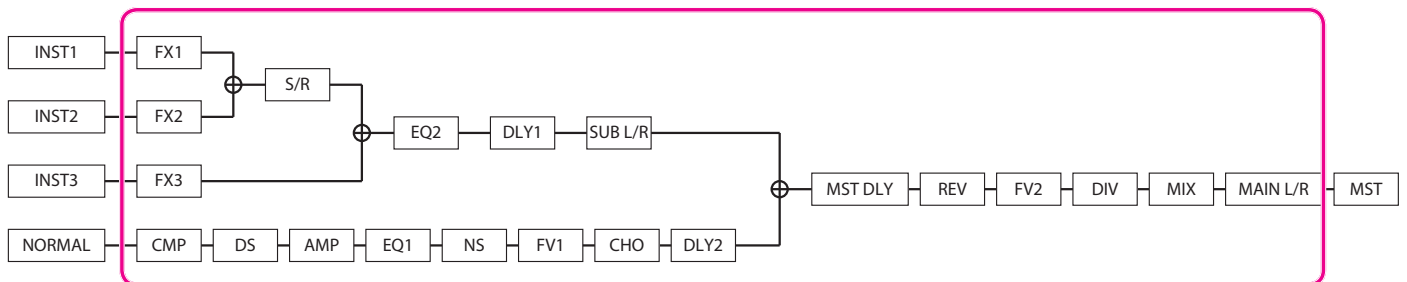

### MEMO

- In order to distinguish between the divided pickup and the conventional pickup installed on your guitar (bass), this manual uses the term “normal pickup” when referring to the conventional pickup of your guitar (bass).
- The sound of the normal pickup directly connected to the GUITAR INPUT jack or the sound of the normal pickup routed through the divided pickup is input to the NORMAL block. You can mix this into the INST1–INST3 blocks.

# INST Parameters

## 1. Press the [INST] button.

The INST screen appears.



The INST screen shows the INST TYPE of INST1–INST3.

### MEMO

- The parameters shown depend on the type of instrument that you select.
- INST1–INST3 are common parameters.

## Availability of Functions for Each INST TYPE (GUITAR MODE)

INST TYPE	ALT. TUNE	12STR	STR BEND	STRING LEVEL	STRING PAN	AMP Modeling	NS	EQ
DYNAMIC SYNTH	✓	–	✓	✓	✓	–	–	–
OSC SYNTH	✓	–	✓	✓	✓	–	–	–
GR-300	✓	–	✓	✓	✓	–	–	–
E.GUITAR	✓	✓	✓	✓	✓*1	✓*1	✓	✓
ACOUSTIC	✓	✓	✓	✓	✓*1	✓*1	✓	✓
E.BASS	✓	✓	✓	✓	✓*1	✓*1	✓	✓
VIO GUITAR	✓	–	✓	✓	✓	–	✓	✓
POLY FX	✓	–	✓	✓	✓	–	✓	–

\*1 If AMP Modeling is ON, the PAN effect disappears.

## Availability of Functions for Each INST TYPE (BASS MODE)

INST TYPE	ALT. TUNE	12STR	STR BEND	STR LEVEL	STR PAN	AMP Modeling	NS	EQ
DYNAMIC SYNTH	✓	–	✓	✓	✓	–	–	–
OSC SYNTH	✓	–	✓	✓	✓	–	–	–
ANALOG GR	✓	–	✓	✓	✓	–	–	–
E.BASS	✓	✓	✓	✓	✓*1	✓*1	✓	✓
AC BASS	✓	✓	✓	✓	✓*1	✓*1	✓	✓
E.GUITAR	✓	✓	✓	✓	✓*1	✓*1	✓	✓
POLY FX	✓	–	✓	✓	✓	–	✓	–

\*1 If AMP Modeling is ON, the PAN effect disappears.

## INST TYPE

Value	Explanation
<b>DYNAMIC SYNTH</b>	This is a synthesizer that produces a sound that responds to the natural nuances of your performance.
<b>OSC SYNTH</b>	This is a synthesizer that detects the pitch and attack information in the input sound and outputs signals produced by the built-in oscillator.
<b>GR-300</b> *2	This models the Roland GR-300, the famed analog polyphonic guitar synthesizer of yesteryear. It provides hexa-distortion, with a hexa-VCO and VCF (variable frequency filter) that generates independent pitch-shiftable sawtooth waves for the six strings, letting you enjoy analog synthesizer sounds that reflect the nuances of your guitar performance.
<b>ANALOG GR</b> *3	This is the sound of a vintage analog polyphonic bass synthesizer. It provides hexa-distortion, with a hexa-VCO and VCF (variable frequency filter) that generates independent pitch-shiftable sawtooth waves for the six strings, letting you enjoy analog synthesizer sounds that reflect the nuances of your bass performance.
<b>E.GUITAR</b> *1	This provides a variety of electric guitar sounds.
<b>ACOUSTIC</b> *1 *2	This provides a variety of acoustic guitar sounds.
<b>AC BASS</b> *1 *3	This provides a variety of acoustic bass sounds.
<b>E.BASS</b> *1	This provides a variety of electric bass sounds.
<b>VIO GUITAR</b> *2	By adding overtones (harmonics), this provides a soft and distinctive tone.
<b>POLY FX</b>	This is an effect processor that independently processes the signal of each string.

## Parameters Common to Each INST TYPE (COMMON)

Parameter	Value	Explanation
<b>INST ON/OFF</b>	OFF, ON	Instrument on/off
<b>INST LEVEL</b>	0–100	Specifies the volume of the instrument.
<b>NOR MIX SW</b>	OFF, ON	Turns on/off the signal of the normal pickup.
<b>NOR MIX LEVEL</b> *1	0–200	Adjusts the volume of the normal pickup.
<b>STRING LEVEL6–STRING LEVEL1</b> *2	0–100	Specifies the output level of each string.
<b>STR LEVEL LowB</b>		
<b>STR LEVEL 4th, STR LEVEL 3rd, STR LEVEL 2nd, STR LEVEL 1st, STR LEVEL HiC</b> *3		

Parameter	Value	Explanation
<b>STRING PAN 6–STRING PAN 1</b> *2	L50–CENTER–R50	Specifies the left/right pan of each string. * The pan effect is canceled if a monaural effect is connected after the instrument.
<b>STR PAN LowB</b>		
<b>STR PAN 4th, STR PAN 3rd, STR PAN 2nd, STR PAN 1st, STR PAN HiC</b> *3		
<b>VARIATION</b>		

\*1 If the INST TYPE is E.GUITAR, ACOUSTIC, AC BASS, or E.BASS, the signal that passes through NOR MIX LEVEL is mixed directly before AMP Modeling. Refer to "Signal flow for the NOR MIX LEVEL parameter" (p. 23).

\*2 Valid in the GUITAR MODE.

\*3 Valid in the BASS MODE.

## Signal flow for the NOR MIX LEVEL parameter

The flow of the signal that passes through the NOR MIX LEVEL depends on the INST TYPE.

### DYNAMIC SYNTH, OSC SYNTH

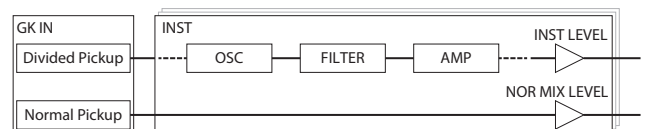

### GR-300, ANALOG GR, POLY FX

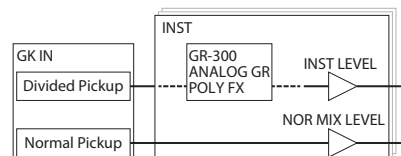

### E.GUITAR, ACOUSTIC, AC BASS, E.BASS

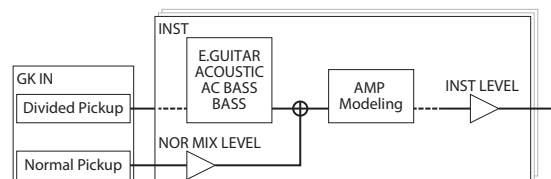

### VIO GUITAR

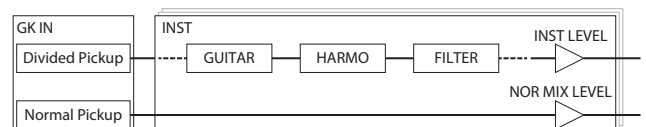

## Parameters Common to Each INST TYPE (ALT TUNE)

Without changing the tuning of the guitar (bass) on which the divided pickup is installed, you can instantly switch to a variety of other tunings.

By using the ALT TUNE function for each INST, you can simultaneously play a 6-string guitar and a 12-string guitar, create harmonies by yourself, or play rich unison sounds.

Parameter	Value	Explanation
ON/OFF	OFF, ON	Switches the alternate tuning function on/off.
TUNING TYPE	OPEN D, OPEN E, OPEN G, OPEN A *1	Tuning that produces a major chord when you play the open strings.
	DROP D–DROP A *1	DROP-D is a tuning in which only the 6th string is dropped to D. The other tunings are the variations that are transposed downward parallel to Drop D.
	D-MODAL *1	Tuning that drops the 6th, 2nd, and 1st string by a whole step to create an ethnic feel.
	NASHVL *1	Tuning that raises the 6th, 5th, 4th, and 3rd strings by one octave; like a 12-string guitar's secondary strings by themselves.
	-12--+12 STEP	Raises/lowers the tuning of all strings in semitone steps.
	USER	User tuning in which each string can be specified individually.
PITCH 6–PITCH 1 *1 *3	-24--+24	Specifies the amount of pitch shift in semitones for each string.
PITCH LowB, PITCH 4th, PITCH 3rd, PITCH 2nd, PITCH 1st, PITCH HiC *2 *3		
FINE 6–FINE 1 *1 *3	-50--+50	Finely adjusts the pitch of each string. -50 is half a semitone down; +50 is half a semitone up.
FINE LowB, FINE 4th, FINE 3rd, FINE 2nd, FINE 1st, FINE HiC *2 *3		

Parameter	Value	Explanation
12STR SW *4	OFF, ON	Turn this on if you want the sound of a 12-string guitar. This changes the sound of a regular six-string guitar to that of a twelve-string guitar featuring secondary strings.
12STR TYPE *4	NORMAL	The conventional tuning of a 12-string guitar.
	USER	A user tuning that specifies the pitch of each secondary string.
12STR PITCH 6–12STR PITCH 1 *1 *4 *5	-24--+24	This sets the amount of pitch shift for secondary strings, in semitone steps.
12PITCH LowB, 12PITCH 4th, 12PITCH 3rd, 12PITCH 2nd, 12PITCH 1st, 12PITCH HiC *2 *4 *5		
12STR LEVEL 6–12STR LEVEL 1 *1 *4 *5	0–100	Specifies the volume of the secondary strings.
12LEVEL LowB 12LEVEL 4th 12LEVEL 3rd 12LEVEL 2nd 12LEVEL 1st 12LEVEL HiC *2 *4 *5		
12STR FINE 6–12STR FINE 1 *1 *4 *5	-50--+50	Finely adjusts the pitch of the secondary strings. -50 is half a semitone down; +50 is half a semitone up.
12FINE LowB, 12FINE 4th, 12FINE 3rd, 12FINE 2nd, 12FINE 1st, 12FINE HiC *2 *4 *5		
12STR DELAY 6–12STR DELAY 1 *1 *4 *5	0ms–100ms	Adjusts the time the sound of each secondary string is delayed relative to the respective main string.
12DELAY LowB, 12DELAY 4th, 12DELAY 3rd, 12DELAY 2nd, 12DELAY 1st, 12DELAY HiC *2 *4 *5		
STR BEND SW	OFF, ON	Turns the String Bend function on/off.

Parameter	Value	Explanation
BEND CONTROL	0–100	Setting this to 0 makes for no shift in pitch by bend, and setting it to 100 produces shifting according to the settings for BEND DEPTH6–BEND DEPTH1 (LowB–HiC). Normally, this pitch bend is set to 0, and the setting 0–100 assigned with Control Assign is used.
BEND DEPTH6–BEND DEPTH1 *1	-24–+24	This sets the amount of pitch shift in each string when the BEND CONTROL is set to 100.  The amount of pitch shift from the current pitch is set in semitone increments.
BEND DEPTH LowB, BEND DEPTH 4th, BEND DEPTH 3rd, BEND DEPTH 2nd, BEND DEPTH 1st, BEND DEPTH HiC *2		

\*1 Valid in the GUITAR MODE.

\*2 Valid in the BASS MODE.

\*3 Valid when the TUNING TYPE is set to USER.

\*4 Valid when the INST TYPE is set to E.GUITAR, E.BASS, ACOUSTIC, or AC BASS.

\*5 Valid when the 12STR TYPE is set to USER.

## DYNAMIC SYNTH Parameters

### OSC

In the OSC section you specify the waveform that is the basis of the synthesizer sound.

Parameter	Value	Explanation
WAVEFORM		Selects the waveform that is the basis of the sound.
	SIN	Sine wave
	SAW	Sawtooth wave
	TRI	Triangle wave
	SQR	Square wave
	PWM	Pulse wave (asymmetrical rectangular wave)
	DETUNE SAW	Two sawtooth waves of slightly different pitch
	NOISE	Noise
	FEEDBACK OSC *1	A sound containing high overtones similar to guitar feedback playing. Suitable for creating crisply aggressive tones that stand out.
	SUPER SAW *1	The sound of seven sawtooth waves playing simultaneously. Pitch-shifted sounds are added to the center sound. This is appropriate when creating rich sounds such as strings.
INPUT *2	The input signal is used without modification.  <b>When using a GK PATCH</b> The signal of the divided pickup is used.  <b>When using a NORMAL PATCH</b> The signal of the normal pickup is used.	
PITCH	-24–+24	Adjusts the pitch.
FINE	-50–+50	Specifies a finer adjustment than PITCH.
PULSE WIDTH *3	0–100	Specifies the pulse width. This specifies the width of the upper portion of the rectangular wave as a percentage of the overall cycle. Smaller values produce a narrower pulse, approaching a square wave (pulse width = 50%). Larger values widen the pulse, producing a more distinctive sound.
PWM ENV ATTACK *3	-50–+50	Uses the dynamics of the input signal to control the pulse width of PWM. Values in the positive direction speed up the release of the pulse width, and values in the negative direction slow down the attack of the pulse width.
PITCH ENV DEPTH *3	-50–+50	Specifies the depth to which PWM is modulated by the dynamics of the input signal.

Parameter	Value	Explanation
<b>DETUNE</b> *4	-50+50	Specifies the amount of detuning.
<b>SHARPNESS</b> *5	0-100	Specifies the frequency range of the noise that is heard. Larger values strengthen the sense of pitch.
<b>FEEDBACK</b> *6	0-100	Adjusts the amount of feedback. Larger values increase the amount of feedback, changing the volume of the harmonics.
<b>HARMONICS</b> *6	0-100	Specifies the tonal character of the harmonics.
<b>S-SAW DETUNE</b> *7	0-100	Specifies the amount of pitch spread between the seven sawtooth waves that are layered within one oscillator.
<b>P. ENV ATTACK</b>	-50+50	Uses the dynamics of the input signal to control the pitch. Values in the positive direction speed up the pitch release, and values in the negative direction slow down the pitch attack.
<b>P. ENV DEPTH</b>	-50+50	Specifies the depth to which pitch is modulated by the dynamics of the input signal.
<b>P. BEND DEPTH</b>	-24+24	Specifies the depth of bend.
<b>P. BEND CTL</b>	0-100	This parameter controls the bend. Assign this when using a CTL pedal or EXP pedal to control bend.
<b>SYNC SW</b> *8 *9	OFF, ON	Switches oscillator sync on/off. If this is ON, it generates a complex waveform by forcibly resetting INST2 and INST3 to the beginning of their cycle in synchronization with the INST1 frequency.
<b>RING SW</b> *8	OFF, ON	Switches the ring modulator on/off. If this is on, the signals of INST1 and INST2 (or INST1 and INST3) are multiplied with each other to produce a complex waveform.

- \*1 Setting available with GK PATCH.
- \*2 If INPUT is selected as WAVEFORM, there are no editable parameters in the OSC block.
- \*3 Valid when the WAVEFORM is set to PWM.
- \*4 Valid when the WAVEFORM is set to DETUNE SAW.
- \*5 Valid when the WAVEFORM is set to NOISE.
- \*6 Valid when the WAVEFORM is set to FEEDBACK OSC.
- \*7 Valid when the WAVEFORM is set to SUPER SAW.
- \*8 Valid only when the INST1 TYPE (p. 23) is set to DYNAMIC SYNTH.
- \*9 Valid when the WAVEFORM is set to other than NOISE or INPUT.

## FILTER

Sound consists of numerous overtones at various frequencies. By using a filter to pass or cut the overtones of specific frequency regions, you can modify the brightness of the sound.

In the FILTER section you can modify the brightness of the sound by changing the type of filter and applying various changes to the output waveform.

Parameter	Value	Explanation
<b>ON/OFF</b>	OFF, ON	Switches filter on/off.
<b>TYPE</b>	Type of filter	
	LPF	The region above the cutoff frequency will be cut, making the sound more mellow.
	HPF	The region below the cutoff frequency will be cut, emphasizing the high-frequency range.
	BPF	It passes only the range of frequencies in the region of the cutoff frequency, cutting the other frequencies.
	PKG	Boosts the range of frequencies in the region of the cutoff frequency.
	LADDER LPF	A ladder-type low-pass filter.
LADDER HPF	A ladder-type high-pass filter.	
<b>SLOPE</b> *1	-12 dB, -24 dB	Selects the slope (steepness) of the low-pass filter.
<b>CUTOFF</b>	0-100	Adjusts the cutoff frequency.
<b>RESONANCE</b>	0-100	Resonance emphasizes the sound in the region of the filter cutoff frequency.
		Increasing the resonance setting will increase this emphasis, producing a distinctive sound that is characteristic of synthesizers.
<b>F. ENV ATTACK</b>	-50+50	Specifies how the dynamics of the input signal controls the filter. Values in the positive direction speed up the filter release. Values in the negative direction slow down the filter attack.
<b>F. ENV DEPTH</b>	-50+50	Specifies the depth to which the filter is modulated by the dynamics of the input signal.

\*1 Valid when the TYPE is set to LPF, HPF, BPF, PKG.

## AMP

In the AMP section you can modify the sound by changing its volume and dynamics.

Parameter	Value	Explanation
<b>A. ENV ATTACK</b>	-50+50	Specifies how the dynamics of the input signal controls the amp.
<b>LOW CUT</b>	FLAT, 20.0 Hz-16.0 kHz	Cuts the frequency region below the specified frequency. When FLAT is selected, the low cut filter will have no effect.
<b>HIGH CUT</b>	20.0 Hz-16.0 kHz, FLAT	Cuts the frequency region above the specified frequency. When FLAT is selected, the high cut filter will have no effect.

## LFO1, LFO2

Here you can cyclically modulate the sound by applying vibrato to modulate the pitch or applying tremolo to modulate the volume.

Parameter	Value	Explanation
ON/OFF	OFF, ON	Turns the LFO1/LFO2 on/off.
SHAPE	Selects the waveform of LFO1 and LFO2.	
	SIN	Sine wave
	SAW UP	Sawtooth wave
	SAW DOWN	Sawtooth wave (negative polarity)
	TRI	Triangle wave
	SQR	Square wave
	RANDOM	Random wave
S&H	Sample and Hold	
RATE *3	0–100, BPM 	Determines the speed of the LFO1/LFO2.
DYNAMIC DEPTH	OFF, ON	Specifies whether the dynamics of the input signal controls the depth at which LFO1 and LFO2 are applied.
PITCH DEPTH	0–100	Allows the LFO to modulate the pitch, producing a vibrato effect.
FILTER DEPTH	0–100	Allows the LFO to modulate the FILTER CUTOFF (cutoff frequency).
AMP DEPTH	0–100	Allows the LFO to modulate the AMP LEVEL (volume), producing a tremolo effect.
PWM DEPTH *1	0–100	Adjusts the depth at which PWM is modulated.
FADE TIME *2	0–100	Specifies the time until the LFO reaches its maximum amplitude.
SYNC	OFF, ON	If SYNC is ON, you can use the CONTROL FUNCTION parameter SYNC TRIG (p. 68) or the ASSIGN SETTING parameter SYNC RETRIGGER (p. 73) to retrigger the start timing of the LFO.
BPM	40–250	Adjusts the BPM value for each patch.
VARIATION1&2	PATCH, 01–50	LFO1 and LFO2 settings can be saved/loaded as 50 different variations. A saved VARIATION can be loaded into a different patch, which is convenient when you're creating sounds.

\*1 Valid when the WAVEFORM (p. 25) in the OSC section is set to PWM.

\*2 Valid when the DYNAMIC DEPTH is ON.

\*3 Refer to "About effects when a note value is selected as a setting" (p. 66).

## SEQ

This is a step sequencer function with up to 16 steps. You can create complex changes by combining steps with a different envelope at each step.

### COMMON

Parameter	Value	Explanation
VARIATION1&2	PATCH, 01–50	SEQUENCER1, SEQUENCER2, and TARGET settings can be saved/loaded as 50 different variations. A saved VARIATION can be loaded into a different patch, which is convenient when you're creating sounds.

### SEQUENCER 1, SEQUENCER 2

Parameter	Value	Explanation
ON/OFF	OFF, ON	Turns the SEQUENCER1/ SEQUENCER2 on/off.
SYNC	OFF, ON	Specifies whether the start timing of the LFO for which SYNC is ON is synchronized with the SEQUENCER. The start timing is retriggered using the CONTROL FUNCTION parameter SYNC TRIG (p. 68) or the ASSIGN SETTING parameter SYNC RETRIGGER (p. 73).
1SHOT	OFF, ON	If this is on, the steps specified by the LOOP LENGTH of SEQUENCER1 and SEQUENCER2 will play only once.
TURBO	OFF, ON	If this is ON, operation is twice as fast as specified by RATE.
RATE *1	0–100, BPM 	Specifies the rate at which the sequence pattern of SEQUENCER1 or SEQUENCER2 repeats.
LOOP LENGTH	1–16	Specifies the length (number of steps) of SEQUENCER1 or SEQUENCER2 that is repeated.

### TARGET

Parameter	Value	Explanation
PITCH *2	OFF, SEQ1, SEQ2	Specifies the SEQUENCER that is assigned to the OSC section's PITCH (p. 25).
CUTOFF	OFF, SEQ1, SEQ2	Specifies the SEQUENCER that is assigned to the FILTER section's CUTOFF (p. 26).
LEVEL	OFF, SEQ1, SEQ2	Specifies the SEQUENCER that is assigned to the INST COMMON section's INST LEVEL (p. 23).

\*1 Refer to "About effects when a note value is selected as a setting" (p. 66).

\*2 If the OSC section's WAVEFORM (p. 25) is set to INPUT, the PITCH does not change.

## SEQ1, SEQ2

Parameter	Value	Explanation
PITCH STEP1-STEP 16 MAX	-24+24	Specify the width of PITCH change for each STEP.
PITCH STEP1-STEP16 MIN		
CUTOFF STEP1-STEP16 MAX	0-100	Specify the width of CUTOFF change for each STEP.
CUTOFF STEP1-STEP16 MIN		
LEVEL STEP1-STEP16 MAX	0-100	Specify the width of INST LEVEL change for each STEP.
LEVEL STEP1-STEP16 MIN		
STEP1-STEP16 CURVE	Specify the curve of change for each step of SEQUENCER1 and SEQUENCER2.	

## About SEQUENCER

If you make eight steps of sequence settings with STEP CURVE, PITCH MIN, and PITCH MAX set as shown in the table below, the output will be as indicated by the graph.

Example of an eight-step sequence

STEP	1	2	3	4	5	6	7	8
STEP CURVE								
PITCH MIN	-12	-9	-6	-3	0	+3	+6	+9
PITCH MAX	-9	-6	-3	0	+3	+6	+9	+12

Output example

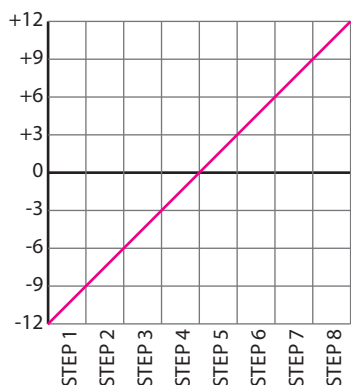

## About STEP CURVE

STEP CURVE provides a choice of the following 13 types.



## Editing the sequencer

1. Turn the [6] knob to select "SEQ."

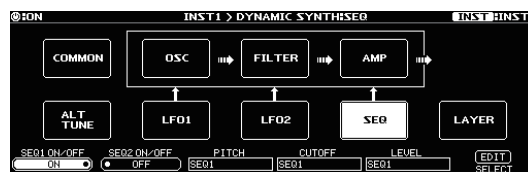

2. Press the [6] knob.

The SEQUENCE COMMON screen appears.

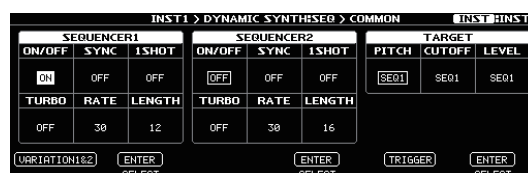

3. Specify how SEQUENCER1 and SEQUENCER2 operate.

Knob	Explanation
[1] knob	Accesses the SEQUENCER1 and SEQUENCER2 VARIATION screen.
[2] knob	Set the parameters of SEQUENCER1.
[4] knob	Set the parameters of SEQUENCER2.
[6] knob	Specify which sequencer controls PITCH, CUTOFF, and LEVEL.

4. Use the [◀] [▶] (PAGE) buttons to switch to the SEQUENCER1 or SEQUENCER2 screens.

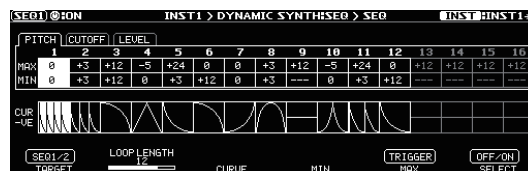

Operation	Explanation
Turn the [1] knob	Switch the TARGET editing screen (PITCH, CUTOFF, LEVEL).
Press the [1] knob	Switch the SEQ1 and SEQ2 screens.
Turn the [2] knob	Specify the LOOP LENGTH (length of the sequencer loop).
Turn the [3] knob	Specify the CURVE of the selected step.
Turn the [4] knob	Adjust the MIN value of the parameter selected by the cursor.
Turn the [5] knob	Adjust the MAX value of the parameter selected by the cursor.
Press the [5] knob	Retrigger the LFO or SEQUENCER for which SYNC (p. 27) is ON.
Turn the [6] knob	Select the step to edit.
Press the [6] knob	Switch the sequencer on/off.

\* If a parameter to be controlled (PITCH, CUTOFF, LEVEL) is not assigned to the sequencer, these settings have no effect (they are shown in gray).

\* Settings of steps that are beyond the value specified by LENGTH have no effect (they are shown in gray).

## LAYER

Here you can specify the range of notes that are sounded. This is useful when layering multiple sounds together.

Parameter	Value	Explanation
L. FADE	1–60	Specifies the area over which the low range will fade out.
LOWER	A0–E6	Specifies the lowest note of the range that will sound.
UPPER	A0–E6	Specifies the highest note of the range that will sound.
U. FADE	1–60	Specifies the area over which the high range will fade out.

\* Valid when the WAVEFORM (p. 25) in the OSC section is set to other than INPUT.

## OSC SYNTH Parameters

### OSC

In the OSC section you specify the waveform that is the basis of the synthesizer sound.

Parameter	Value	Explanation
MODE		This creates the waveform that determines the character of the sound, and also specifies the pitch. There are two oscillators (OSC1 and OSC2).
	SINGLE	Only OSC1 is used.
	DUAL	OSC1 and OSC2 are used.
	SYNC	This is oscillator sync. It generates a complex waveform by forcibly resetting OSC2 to the beginning of its cycle in synchronization with the OSC1 frequency.
WAVEFORM1 WAVEFORM2	RING	This is a ring modulator. It generates a complex waveform by multiplying OSC1 and OSC2.
		Selects the waveform that is the basis of the sound.
	SIN	Sine wave
	SAW	Sawtooth wave
	TRI	Triangle wave
	SQR	Square wave
PITCH1 PITCH2	PWM	Pulse wave (asymmetrical rectangular wave)
	NOISE	Noise
FINE1 FINE2	-24–+24	Adjusts the pitch.
PULSE WIDTH1 PULSE WIDTH2 *1	-50–+50	Specifies a finer adjustment than PITCH.
PW MOD RATE1 PW MOD RATE2 *1	0–100	Specifies the pulse width.
P. ENV ATTACK1 P. ENV ATTACK2	0–100	Specifies the depth to which the LFO will modulate pulse width.
P. ENV DECAY1 P. ENV DECAY2	0–100	Specifies the attack/decay time of the pitch envelope.
P. ENV DEPTH1 P. ENV DEPTH2	0–100	Specifies the depth to which the envelope will modulate the pitch.
LEVEL1 LEVEL2	0–100	Specifies the volume of the oscillator.
MONO/POLY SW	MONO, POLY	If this is set to MONO, only a single note will sound even if you play a chord.

Parameter	Value	Explanation
CHROMATIC	OFF, ON	Turn this "ON" if you want to play tones in semitone increments. If this is "ON," the pitch will change in semitone steps even when you bend notes.
PORTA SW	OFF, ON	Specifies whether portamento is applied. When this is set to ON, you can create a smooth change in pitch from one note to the next.
PORTA TIME	0-100	Specifies the time required for the pitch change when using portamento. Larger values lengthen the time during which the pitch of the next note is reached.
PORTA MODE *2	Selects how portamento is applied.	
	MODE1	The portamento effect is applied starting at the final pitch sounded by each string.
	MODE2	The portamento effect is applied starting at the final pitch sounded, regardless of the string that was played.
HOLD MODE	Specifies the operation of the Hold function using CONTROL FUNCTION and ASSIGN FUNCTION. * In order to use the Hold function, make settings for "CONTROL FUNCTION" (p. 67) and "ASSIGN SETTING" (p. 70).	
	MODE1	Notes that are newly played while Hold is on will also be held.
	MODE2	Newly played notes are not accepted while Hold is on.
	MODE3	While Hold is on, notes newly played on a string that's being held are accepted.
LOW VELO CUT	OFF, 1-10	Adjust this if simply touching a string causes a note to be unintentionally triggered. Raising this value will make it more difficult to trigger notes.

\*1 Valid when the WAVEFORM1 or WAVEFORM2 is set to PWM.

\*2 Valid when the MONO/POLY SW is set to POLY.

## FILTER

Sound consists of numerous overtones at various frequencies. By using a filter to pass or cut the overtones of specific frequency regions, you can modify the brightness of the sound.

In the FILTER section you can modify the brightness of the sound by changing the type of filter and applying various changes to the output waveform.

Parameter	Value	Explanation
ON/OFF	OFF, ON	Switches filter on/off.
TYPE	Type of filter	
	LPF	The region above the cutoff frequency will be cut, making the sound more mellow.
	HPF	The region below the cutoff frequency will be cut, emphasizing the high-frequency range.
	BPF	It passes only the range of frequencies in the region of the cutoff frequency, cutting the other frequencies.
	PKG	Boosts the range of frequencies in the region of the cutoff frequency.
	LADDER LPF	A ladder-type low-pass filter.
	LADDER HPF	A ladder-type high-pass filter.
SLOPE *1	-12 dB, -24 dB	Selects the slope (steepness) of the low-pass filter.
CUTOFF	0-100	Adjusts the cutoff frequency.
CUTOFF FOLLOW	0-100	Specifies how the cutoff frequency will be affected by the note position.
RESONANCE	0-100	Resonance emphasizes the sound in the region of the filter cutoff frequency. Increasing the resonance setting will increase this emphasis, producing a distinctive sound that is characteristic of synthesizers.
VELOCITY SENS	-50+50	Specifies how the filter envelope depth is affected by your picking dynamics.
F. ENV ATTACK	0-100	Specifies the attack/decay/sustain level/ release time of the filter envelope.
F. ENV DECAY	0-100	
F. ENV SUSTAIN	0-100	
F. ENV RELEASE	0-100	
F. ENV DEPTH	-50+50	Specifies the depth and direction of the cutoff frequency change. Higher values make the cutoff frequency move upward. Lower values make the cutoff frequency move downward.

\*1 Valid when the TYPE is set to LPF, HPF, BPF, or PKG.

## AMP

In the AMP section you can modify the sound by changing its volume and dynamics.

Parameter	Value	Explanation
VELOCITY SENS	0–100	Specifies the sensitivity to the strength at which you pick the string.
A. ENV ATTACK	0–100	Specifies the attack/decay/sustain level, and release time of the AMP.
A. ENV DECAY	0–100	
A. ENV SUSTAIN	0–100	
A. ENV RELEASE	0–100	
LOW CUT	FLAT, 20.0 Hz–16.0 kHz	Cuts the frequency region below the specified frequency. When FLAT is selected, the low cut filter will have no effect.
HIGH CUT	20.0 Hz–16.0 kHz, FLAT	Cuts the frequency region above the specified frequency. When FLAT is selected, the high cut filter will have no effect.

## LFO1, LFO2

Here you can cyclically modulate the sound by applying vibrato to modulate the pitch or applying tremolo to modulate the volume.

Parameter	Value	Explanation
ON/OFF	OFF, ON	Turns the LFO1/LFO2 on/off.
SHAPE	Selects the waveform of LFO1 and LFO2.	
	SIN	Sine wave
	SAW UP	Sawtooth wave
	SAW DOWN	Sawtooth wave (negative polarity)
	TRI	Triangle wave
	SQR	Square wave
	RANDOM	Random wave
	S&H	Sample and Hold
RATE *1	0–100, BPM 	Determines the speed of the LFO1/LFO2.
PITCH1 DEPTH PITCH2 DEPTH	0–100	Allows the LFO to modulate the pitch, producing a vibrato effect.
FILTER DEPTH	0–100	Allows the LFO to modulate the FILTER CUTOFF (cutoff frequency).
AMP DEPTH	0–100	Allows the LFO to modulate the AMP LEVEL (volume), producing a tremolo effect.
DELAY TIME	0–100	Specifies the time from when a note is played until the LFO begins to apply.
FADE TIME	0–100	Specifies the time until the LFO reaches its maximum amplitude.

Parameter	Value	Explanation
SYNC	OFF, ON	Specifies whether the start timing of the LFO for which SYNC is ON is synchronized with the SEQUENCER.  The start timing is retriggered using the CONTROL FUNCTION parameter SYNC TRIG (p. 68) or the ASSIGN SETTING parameter SYNC RETRIGGER (p. 73).
BPM	40–250	Adjusts the BPM value for each patch.
VARIATION1&2	PATCH, 01–50	LFO1 and LFO2 settings can be saved/loaded as 50 different variations.  A saved VARIATION can be loaded into a different patch, which is convenient when you're creating sounds.

\*1 Refer to “About effects when a note value is selected as a setting” (p. 66).

## GR-300 (In GUITAR MODE) / ANALOG GR (In BASS MODE) Parameters

### GR-300/ANALOG GR

Parameter	Value	Explanation
MODE		Specifies whether to sound the hexa-VCO (sawtooth wave), the hexa-distortion (square wave), or both.
	VCO	Only the hexa-VCO will sound.
	V+D	The hexa-VCO and hexa-distortion will sound together.
	DIST	Only the hexa-distortion will sound.
COMP SW *1	OFF, ON	If this is "ON," the decay time of the hexa-VCO will be extended.
CUTOFF	0-100	Adjusts the cutoff frequency at which the filter cuts off the sound's harmonic components.
RESONANCE	0-100	Adjusts the amount of filter resonance (distinctiveness of the sound) used.
ENV MOD SW		This automatically changes the VCF cutoff frequency according to the amplitude of the string vibration. This allows you to change the tone with a wah-like effect each time you pick a string.
	OFF	Turns envelope modulation off.
	ON	This causes the VCF cutoff frequency to change from a high to low frequency each time the string is picked. This produces a wah-like effect, with the sound going from high frequencies to low.
	INV	As opposed to the ON setting, this allows you to have the VCF cutoff frequency change from a low to high frequency each time the string is picked. This produces a reverse wah-like effect, with the sound going from low frequencies to high.
ENV MOD SENS	0-100	Adjusts the input sensitivity of the envelope modulation. As the value is raised, the change from the envelope modulation broadens with even weaker picking.
ENV MOD ATTACK	0-100	Adjusts the attack time for the change in the envelope modulation produced by picking. Raising the value slows the attack for this change.
PITCH SW *1	OFF, A, B	This setting allows you to switch A, B and OFF the pitch shift, which enables the pitch of the HEXA-VCO sound to shift in response. * Pitch shift applies only to the hexa-VCO; it does not apply to hexa-distortion.
PITCH A PITCH B *1	-12+12	This sets the amount of shift in pitch from the original sound in semitone increments.

Parameter	Value	Explanation
FINE A FINE B *1	-50+50	This finely adjusts the pitch. -50 is half a semitone down; +50 is half a semitone up.
DUET SW *1	OFF, ON	If this is "ON," a sawtooth wave at the same pitch as the original sound will be added to the hexa-VCO, making the sound richer.  <b>MEMO</b> By setting the hexa-VCO's pitch shift to a PITCH setting such as +/-12 (an octave up/down), +/- 7 (a perfect fifth), or +/-5 (a perfect fourth), you can create thick, synthesizer-like sounds. By setting PITCH FINE to about "+/- 5" to slightly skew the pitch shift of the hexa-VCO, you can give the sound greater depth.
SWEEP SW *1	OFF, ON	This is a Sweep function that smoothly changes the amount of shift when you use PITCH SW to vary the amount of pitch shift.
SWEEP RISE *1	0-100	Adjusts the amount of time for the pitch to shift when the PITCH SW parameter is switched and the sound changes to a higher pitch. If this is "0," the change will occur instantly; higher values produce slower change.
SWEEP FALL *1	0-100	Adjusts the amount of time for the pitch to shift when the PITCH SW parameter is switched and the sound changes to a lower pitch. If this is "0," the change will occur instantly; higher values produce slower change.
VIBRATO SW *1	OFF, ON	Allows you to apply electronic vibrato to the hexa-VCO.
VIBRATO RATE *1	0-100	Adjusts the rate of the vibrato.
VIBRATO DEPTH *1	0-100	Adjusts the depth of the vibrato.
LOW CUT	FLAT, 20.0 Hz-16.0 kHz	Cuts the frequency region below the specified frequency. When FLAT is selected, the low cut filter will have no effect.
HIGH CUT	20.0 Hz-16.0 kHz, FLAT	Cuts the frequency region above the specified frequency. When FLAT is selected, the high cut filter will have no effect.

\*1 Valid when the MODE is set to VCO or V+D.

## E.GUITAR Parameters

### GUITAR (In GUITAR MODE)

Parameter	Value	Explanation
TYPE		Select the electric guitar type "TYPE" (p. 33).
PU SELECT		Selects the pickup position.
	REAR	Rear pickup
	R+C *1	Rear and center pickups
	CENTER *1	Center pickup
	C+F *1	Center and front pickups
	FRONT	Front pickup
	R+F *2	Rear and front pickups
ALL *3	All pickups	
TONE TYPE *4	MILD, STANDARD, BRIGHT1, BRIGHT2	Selects the fretless tone type.
SENS *4	0-100	This controls the input sensitivity.
DEPTH *4	0-100	This controls the volume of the harmonics.
ATTACK *4	0-100	Adjusts the attack of the picking sound.
RESONANCE *4	0-100	Adds a characteristically resonant quality to the sound.
DIRECT LEVEL *4	0-100	Adjusts the volume of the direct sound.
VOLUME	0-100	Adjusts the volume. With a setting of 0, there will be no sound.
TONE	0-100	Adjusts the tone of the body. The standard value is 100; lowering the value creates a softer tone.

\*1 Valid when the TYPE is set to CLA-ST, MOD-ST, or LIPS.

\*2 Valid when the TYPE is set to TE, LP, P-90, 335, L4, RICK, WIDE RANGE, or BRIGHT HUM.

\*3 Valid when the TYPE is set to LIPS.

\*4 Valid when the TYPE is set to FRETLESS.

### TYPE

Value	Explanation
CLA-ST	The sound of a Fender Stratocaster. Simulates the installation of three single-coil pickups (passive type).
MOD-ST	This models a guitar with three EMG active single-coil pickups.
TE	The sound of a Fender Telecaster. This models a guitar with two single-coil pickups.

Value	Explanation
LP	The sound of a Gibson Les Paul Standard. Simulates the installation of two humbucking pickups (passive type).
P-90	The sound of a Gibson Les Paul Junior. This provides two single-coil pickups of the type used on fixed-neck guitars and affectionately known as soap-bar or dog-ear pickups.
335	The sound of a Gibson ES-335 Dot. Typical semi-acoustic guitar with two humbucking pickups.
L4	The sound of a Gibson L-4 CES. Acoustic body guitar suited for jazz. Equipped with two humbucking pickups and strung with flat wound strings.
RICK	This models a Rickenbacker 360. Semi-hollow body guitar with two unique single-coil pickups.
LIPS	The sound of a Danelectro 56-U3. This models a guitar equipped with three pickups noted for their visual resemblance to lipstick tubes.
WIDE RANGE	This produces the fat sound typical of a larger number of coil windings than on a conventional single-coil pickup.
BRIGHT HUM	A conventional humbucking pickup places two coils side by side, causing the high frequencies to be canceled; however, this model produces a tone that preserves these high frequencies while retaining the characteristics of a humbucking pickup.
FRETLESS	This models a fretless guitar.

### GUITAR (In BASS MODE)

Parameter	Value	Explanation
TYPE		Select the electric guitar type.
	ST	The sound of a Fender Stratocaster. Simulates the installation of three single-coil pickups (passive type).
	LP	The sound of a Gibson Les Paul Standard. Simulates the installation of two humbucking pickups (passive type).
	FRETLESS	This models a fretless guitar.
PU SELECT		Selects the pickup position.
	REAR	Rear pickup
	R+C *1	Rear and center pickups
	CENTER *1	Center pickup
	C+F *1	Center and front pickups
	FRONT	Front pickup
	R+F *2	Rear and front pickups
TONE TYPE *3	MILD, STANDARD, BRIGHT1, BRIGHT2	Selects the fretless tone type.
SENS *3	0-100	This controls the input sensitivity.
DEPTH *3	0-100	This controls the volume of the harmonics.

Parameter	Value	Explanation
ATTACK *3	0-100	Adjusts the attack of the picking sound.
RESONANCE *3	0-100	Adds a characteristically resonant quality to the sound.
DIRECT LEVEL *3	0-100	Adjusts the volume of the direct sound.
VOLUME	0-100	Adjusts the volume. With a setting of 0, there will be no sound.
TONE	0-100	Adjusts the tone of the body. The standard value is 100; lowering the value creates a softer tone.

\*1 Valid when the TYPE is set to ST.

\*2 Valid when the TYPE is set to LP.

\*3 Valid when the TYPE is set to FRETLESS.

## AMP (AMP Modeling)

(When E.GUITAR, ACOUSTIC, AC BASS, or E.BASS is selected)

Parameter	Value	Explanation
ON/OFF	OFF, ON	Turns the AMP on/off.
TYPE	Select the amp type "TYPE" (p. 34).	
GAIN	0-120	Adjusts the distortion of the amp.
SAG	-10-+10	Adjusts the amount by which compression changes in response to the power amp.
RESONANCE	-10-+10	Adjusts the amount by which dynamics is affected by the interaction between the power amp and the speaker transformer.
LEVEL	0-100	Adjusts the volume of the entire preamp. * Be careful not to raise the Level setting too high.
BASS	0-100	Adjusts the tone for the low frequency range.
MIDDLE	0-100	Adjusts the tone for the middle frequency range.
TREBLE	0-100	Adjusts the tone for the high frequency range.
PRESENCE	0-100	Adjusts the tone for the ultra high frequency range.
BRIGHT	OFF, ON	Turns the bright setting on/off. * BRIGHT is valid for some of the amps in TYPE.
GAIN SW	LOW, MIDDLE, HIGH	Provides for selection from three levels of distortion: LOW, MIDDLE, and HIGH. Distortion will successively increase for settings of LOW, MIDDLE and HIGH. * The sound of each Type is created on the basis of the level of MIDDLE.
SOLO SW	OFF, ON	The tone to one suitable for solos.

Parameter	Value	Explanation
SOLO LEVEL	0-100	Adjusts the volume level when the SOLO SW is ON.
SP TYPE	Select the speaker type "SP TYPE" (p. 35).	
MIC TYPE	This setting selects the simulated mic type "MIC TYPE" (p. 35).	
MIC DISTANCE	SHORT, MEDIUM, LONG	Simulates the distance between the mic and speaker. The distance from the speakers is farther in the order of SHORT<MEDIUM<LONG.
MIC POSITION	CENTER  1 cm-10 cm	This simulates the mic position.  Simulates the condition that the mic is set in the middle of the speaker cone.  Simulates the condition that the mic is moved away from the center of the speaker cone.
MIC LEVEL	0-100	Adjusts the volume of the mic.
DIRECT LEVEL	0-100	Adjusts the volume of the direct sound.
VARIATION	PATCH, 01-10	AMP settings can be saved/loaded as ten different variations. A saved VARIATION can be loaded into a different patch, which is convenient when you're creating sounds. These variations are shared with the AMP setting in EFFECT.

## TYPE

Value	Explanation
TRANSPARENT	An amp with a broad frequency range and an extremely flat response.
NATURAL	An unembellished, clean sound that minimizes the amp's idiosyncrasies, such as its trebly character and boomy low end.
BOUTIQUE	Crunch sound that allows the nuances of your picking to be expressed even more faithfully than on conventional combo amps.
SUPREME	Great-feeling crunch sound that responds to the nuances of your picking while taking advantage of the distinctive character of a 4x12" speaker cabinet.
MAXIMUM	An amp that delivers the distinctively great response and tone of a vintage Marshall, while making it even higher gain.
JUGGERNAUT	A large stack sound that has been tweaked extensively in the pursuit of the ultimate metal sound.
X-CRUNCH	Crunch sound that uses MDP to deliver a crisp tone from all strings.
X-HI GAIN	High-gain sound that uses MDP to obtain high-gain sound with a wide range and a great-feeling sense of separation.

Value	Explanation
X-MODDED	Core sound that uses MDP to preserve the definition of the sound even with extreme gain.
JC-120	This models the sound of the Roland JC-120.
TWIN COMBO	This models a Fender Twin Reverb.
DELUXE COMBO	This models a Fender Deluxe Reverb.
TWEED COMBO	This models a Fender Bassman 4 x 10" Combo.
DIAMOND AMP	Models the VOX AC30.
BRIT STACK	This models a Marshall 1959.
RECTI STACK	Models the sound of the Channel 2 MODERN Mode on the MESA/Boogie DUAL Rectifier.
MATCH COMBO	This models the sound input to left input on a Matchless D/C-30.
BG COMBO	This models the sound of the MESA/Boogie combo amp.
ORNG STACK	This models the dirty channel of an ORANGE ROCKERVERB.
BG NR UB METAL	This models the sound that models the high-gain channel of a Bogner Uberschall.
NATURAL BASS	Uncolored clean sound for bass.
X-DRIVE BASS	High-gain sound for bass, using MDP to provide wide range and a good-sounding sense of separation.
CONCERT	This models the Ampeg SVT.
SUPER FLAT	A bass amp with flat response.
FLIP TOP	Models the Ampeg B-15.
B MAN	Models the Fender Bassman 100.
BASS 360	Models the Acoustic 360.
SW-TOUR	Models the SWR SM-400.
AC BASS	An amp ideal for ACOUSTIC BASS.
GK BASS	Models the Gallien-Krueger 800RB.
MARK	Models the Markbass Little Mark III.

## SP TYPE

Value	Explanation
OFF	Turns off the speaker simulator.
ORIGINAL	This is the built-in speaker of the amp you selected with AMP TYPE.
1x8"	This is a compact open-back speaker cabinet with one 8-inch speaker.
1x10"	This is a compact open-back speaker cabinet with one 10-inch speaker.
1x12"	This is a compact open-back speaker cabinet with one 12-inch speaker.
2x12"	This is a general open-back speaker cabinet with two 12-inch speakers.
4x10"	This is an optimal speaker cabinet for a large enclosed amp with four 10-inch speakers.
4x12"	This is an optimal speaker cabinet for a large enclosed amp with four 12-inch speakers.
8x12"	This is a stack of two cabinets each with four 12-inch speakers.
B1x15"	This is a compact open-back speaker cabinet for the bass guitar with one 15-inch speaker.
B1x18"	This is a compact open-back speaker cabinet for the bass guitar with one 18-inch speaker.

Value	Explanation
B2x15"	This is a general open-back speaker cabinet for the bass guitar with two 15-inch speakers.
B4x10"	This is a large speaker cabinet for bass, with four 10-inch speakers in a sealed design.
B8x10"	This is a stack of two cabinets for bass, each with four 10-inch speakers.

## MIC TYPE

Value	Explanation
DYN57	This is the sound of the SHURE SM57. General dynamic mic used for instruments and vocals.
DYN421	This is the sound of the SENNHEISER MD-421. Dynamic mic with extended low end.
CND451	This is the sound of the AKG C451B. Small condenser mic for use with instruments.
CND87	This is the sound of the NEUMANN U87. Condenser mic with flat response.
FLAT	Simulates a mic with perfectly flat response. Produces a sonic image close to that of listening to the sound directly from the speakers (on site).

## NS

(When E.GUITAR, ACOUSTIC, AC BASS, E.BASS, VIO GUITAR, or POLY FX is selected)

This effect reduces the noise and hum picked up by guitar pickups. Since it suppresses the noise in synchronization with the envelope of the guitar sound (the way in which the guitar sound decays over time), it has very little effect on the guitar sound, and does not harm the natural character of the sound.

Parameter	Value	Explanation
ON/OFF	OFF, ON	Turns this effect on/off.
THRESHOLD	0-100	Adjust this parameter as appropriate for the volume of the noise. If the noise level is high, a higher setting is appropriate. If the noise level is low, a lower setting is appropriate. Adjust this value until the decay of the guitar sound is as natural as possible.
RELEASE	0-100	Adjusts the time from when the noise suppressor begins to function until the noise level reaches "0."

## EQ

(When E.GUITAR, ACOUSTIC, AC BASS, E.BASS, or VIO GUITAR is selected)

Adjusts the tone. This is a parametric EQ that lets you adjust four separate frequency ranges.

Parameter	Value	Explanation
ON/OFF	OFF, ON	Turns this effect on/off.
LOW CUT	FLAT, 20.0 Hz-16.0 kHz	Sets the frequency at which the low cut filter begins to take effect. When FLAT is selected, the low cut filter will have no effect.
LOW GAIN	-20 dB--+20 dB	Adjusts the tone for the low frequency range.

Parameter	Value	Explanation
LOW-MID FREQ	20.0 Hz–16.0 kHz	Specifies the center of the frequency range that will be adjusted by the LOW-MID GAIN.
LOW-MID Q	0.5, 1, 2, 4, 8, 16	Adjusts the width of the area affected by the EQ centered at the LOW-MID FREQ. Higher values will narrow the area.
LOW-MID GAIN	-20 dB–+20 dB	Adjusts the low-middle frequency range tone.
HIGH-MID FREQ	20.0 Hz–16.0 kHz	Specifies the center of the frequency range that will be adjusted by the HIGH-MID GAIN.
HIGH-MID Q	0.5, 1, 2, 4, 8, 16	Adjusts the width of the area affected by the EQ centered at the HIGH-MID FREQ. Higher values will narrow the area.
HIGH-MID GAIN	-20 dB–+20 dB	Adjusts the low-middle frequency range tone.
HIGH GAIN	-20 dB–+20 dB	Adjusts the tone for the high frequency range.
HIGH CUT	20.0 Hz–16.0 kHz, FLAT	Cuts the frequency region above the specified frequency. When FLAT is selected, the high cut filter will have no effect.
LEVEL	-20 dB–+20 dB	Adjusts the overall volume level of the equalizer.

## ACOUSTIC Parameters

### ACOUSTIC

Parameter	Value	Explanation
TYPE		Select the acoustic guitar type "TYPE" (p. 37).
BODY *1	0–100	Adjusts the body resonance. Raising the value produces more of a sense of the guitar body in the sound. Lower the value in conditions where feedback is prone to occur.
RESONANCE *2	0–100	Adjusts the body resonance. The resonance increases as the value is raised.
VOLUME	0–100	Adjusts the volume. With a setting of 0, there will be no sound.
TONE	-50–+50	Adjusts the tone of the body. The standard value is 0; raising the value boosts the high range.
ATTACK *3	0–100	Specifies the strength of the attack when you pluck the string strongly. As this setting is increased, the attack will be sharper, and the sound will be crisper.
SUSTAIN *4	0–100	You can specify how the resulting volume will be affected by changes (loud/soft dynamics) in the guitar string vibrations that are input. Adjusts the range (time) over which low-level signals are boosted. Larger values will result in longer sustain.
PU SELECT *5		Selects the pickup position.
	FRONT	Front pickup
	R+F	Rear and front pickups
	REAR	Rear pickup
PIEZO	Piezo pickup	
SENS *5	0–100	Adjusts the input sensitivity.
COLOR *5	0–100	Adjusts the overall tone quality of the sitar.
DECAY *5	0–100	Adjusts the time it takes following the attack for the tone to change.
BUZZ *5	0–100	Adjusts the amount of characteristic buzz produced by the buzz bridge when the strings make contact with it.

\*1 Valid when the TYPE is set to other than RESO or BANJO.

\*2 Valid when the TYPE is set to RESO or BANJO.

\*3 Valid when the TYPE is set to NYLON, BANJO, or SITAR.

\*4 Valid when the TYPE is set to RESO.

\*5 Valid when the TYPE is set to SITAR.

## TYPE

TYPE	Explanation
MA28	The sound of a Martin D-28. Older model known for its exquisitely balanced sound.
TRP-0	The sound of a Martin 000-28. This model features a full low-end resonance and crisp, distinct contour.
GB45	The sound of a Gibson J-45. This vintage model features a unique, seasoned tone with good response.
GB SML	The sound of a Gibson B-25. Featuring a compact body, this vintage model is often used in blues.
GLD40	The sound of a Guild D-40. This model features warm resonance from the body along with a delicate string resonance.
NYLON	This models a nylon-string guitar.
RESO	This models a Dobro-type resonator guitar.
BANJO	This models a conventional five-string banjo.
SITAR	This models a Coral electric sitar. The sitar's distinctive buzz and tonal change are modeled.

## AMP (AMP Modeling)

Refer to "AMP (AMP Modeling)" (p. 34).

## NS

Refer to "NS" (p. 35).

## EQ

Refer to "EQ" (p. 35).

## AC BASS Parameters

### AC BASS

Parameter	Value	Explanation
VOLUME	0–100	Adjusts the volume. With a setting of 0, there will be no sound.
BODY	0–100	This sets the volume level of the resonant sound produced by the panels and cavity (the body resonance).
RESONANCE	0–100	Adjusts the body resonance. The resonance increases as the value is raised.
SIZE	-50–+50	Specifies the size of the body. This modifies the resonant frequency to simulate changes in body size. A setting of 0 will produce a normal resonance.
ATTACK	0–100	Specifies the strength of the attack when you pluck the string strongly. The higher the value you set, the greater the intensity of the sound produced when the strings are played. The attack of the body sound will increase as well.
BOTTOM	0–100	This sets the volume level of string vibration.
BUZZ SENS	0–100	This sets the sensitivity for the distinctive harmonics of an acoustic bass. Adjust this to match the velocity of fingering.
DECAY	0–100	This sets the decay of the string vibration.

## AMP (AMP Modeling)

Refer to "AMP (AMP Modeling)" (p. 34).

## NS

Refer to "NS" (p. 35).

## EQ

Refer to "EQ" (p. 35).

## E.BASS Parameters

### BASS (In GUITAR MODE)

Parameter	Value	Explanation
TYPE	Type of Bass	
	JB	The sound of a Fender Jazz Bass.
	PB	The sound of a Fender Precision Bass.
	FRETLESS	This models a fretless bass.
REAR VOLUME *1	0-100	Sets the volume of the rear pickup.
FRONT VOLUME *1	0-100	Sets the volume of the front pickup.
TONE TYPE *2	Selects the fretless tone type.	
	JB (REAR)	The sound of the rear pickup of a Jazz Bass.
	JB (R+F)	The sound of the rear pickup and front pickup of a Jazz Bass.
	JB (FRONT)	The sound of the front pickup of a Jazz Bass.
	PB	The sound of a Precision Bass.
SENS *2	0-100	This controls the input sensitivity.
DEPTH *2	0-100	This controls the volume of the harmonics.
ATTACK *2	0-100	Adjusts the attack of the picking sound.
RESONANCE *2	0-100	Adds a characteristically resonant quality to the sound.
DIRECT LEVEL *2	0-100	Adjusts the volume of the direct sound.
VOLUME	0-100	Adjusts the volume. With a setting of 0, there will be no sound.
TONE	0-100	Adjusts the tone of the body.

\*1 Valid when the TYPE is set to JB.

\*2 Valid when the TYPE is set to FRETLESS.

### BASS (In BASS MODE)

Parameter	Value	Explanation
TYPE	Select the bass guitar type "TYPE" (p. 39).	
MASTER VOLUME *1	0-100	Sets the overall bass volume level. With a setting of 0, there will be no sound.
REAR VOLUME *1	0-100	Sets the volume of the rear pickup.
FRONT VOLUME *1	0-100	Sets the volume of the front pickup.
REAR TONE *2	0-100	Adjusts the tone of the rear pickup.
FRONT TONE *2	0-100	Adjusts the tone of the front pickup.

Parameter	Value	Explanation
TREBLE *3	0-100	Adjusts the tone for the high frequency range.
BASS *3	0-100	Adjusts the tone for the low frequency range.
PU SELECT *4	Selects the pickup position.	
	REAR	Use the rear pickup.
	R+F	Use both front and rear pickups.
	FRONT	Use the front pickup.
TREBLE ON *5	OFF, ON	Switches the rear pickup on/off.
BASS ON *5	OFF, ON	Switches the front pickup on/off.
RHYTHM/SOLO *5	Switches between rhythm and solo.	
	RHYTHM	The volume will be set to 50.
	SOLO	The volume will be set to 100.
TONE TYPE *6	Selects the fretless tone type.	
	JB (REAR)	The sound of the rear pickup of a Jazz Bass.
	JB (R+F)	The sound of the rear pickup and front pickup of a Jazz Bass.
	JB (FRONT)	The sound of the front pickup of a Jazz Bass.
	PB	The sound of a Precision Bass.
SENS *6	0-100	This controls the input sensitivity.
DEPTH *6	0-100	This controls the volume of the harmonics.
ATTACK *6	0-100	Adjusts the attack of the picking sound.
RESONANCE *6	0-100	Adds a characteristically resonant quality to the sound.
DIRECT LEVEL *6	0-100	Adjusts the volume of the direct sound.
VOLUME *7	0-100	Adjusts the volume. With a setting of 0, there will be no sound.
TONE *8	0-100	Adjusts the tone of the body.

\*1 Valid when the TYPE is set to VINT JB, JB, RICK, T-BIRD, ACTIVE, or VIOLIN.

\*2 Valid when the TYPE is set to RICK.

\*3 Valid when the TYPE is set to M-MAN or ACTIVE.

\*4 Valid when the TYPE is set to RICK.

\*5 Valid when the TYPE is set to VIOLIN.

\*6 Valid when the TYPE is set to FRETLESS.

\*7 Valid when the TYPE is set to VINT PB, PB, M-MAN, or FRETLESS.

\*8 Valid when the TYPE is set to VINT JB, JB, VINT PB, PB, T-BIRD, or FRETLESS.

## TYPE

Value	Explanation
VINT JB	This models a Fender Jazz Bass from the sixties.
JB	This models a Fender Jazz Bass from the late seventies or later.
VINT PB	This models a Fender Precision Bass from the early sixties.
PB	This models a Fender Precision Bass from the late seventies or later.
M-MAN	This models a Music Man StingRay Bass from the seventies.
RICK	This models a Rickenbacker 4001.
T-BIRD	This models a Gibson Thunderbird.
ACTIVE	This models a typical bass equipped with active pickups.
VIOLIN	This models a Höfner Violin Bass.
FRETLESS	This models a fretless bass.

## AMP (AMP Modeling)

Refer to “AMP (AMP Modeling)” (p. 34).

## NS

Refer to “NS” (p. 35).

## EQ

Refer to “EQ” (p. 35).

## VIO GUITAR Parameters

### GUITAR

Parameter	Value	Explanation
TYPE		Select the electric guitar type “TYPE” (p. 33).
PU SELECT		Selects the pickup position.
	REAR	Rear pickup
	R+C *1	Rear and center pickups
	CENTER *1	Center pickup
	C+F *1	Center and front pickups
	FRONT	Front pickup
	R+F *2	Rear and front pickups
	ALL *3	All pickups
	TONE TYPE *4	MILD, STANDARD, BRIGHT1, BRIGHT2
SENS *4	0–100	This controls the input sensitivity.
DEPTH *4	0–100	This controls the volume of the harmonics.
ATTACK *4	0–100	Adjusts the attack of the picking sound.
RESONANCE *4	0–100	Adds a characteristically resonant quality to the sound.
DIRECT LEVEL *4	0–100	Adjusts the volume of the direct sound.
VOLUME	0–100	Adjusts the volume. With a setting of 0, there will be no sound.
TONE	0–100	Adjusts the tone of the body. The standard value is 100; lowering the value creates a softer tone.

\*1 Valid when the TYPE is set to CLA-ST, MOD-ST, or LIPS.

\*2 Valid when the TYPE is set to TE, LP, P-90, RICK, 335, L4, WIDE RANGE, or BRIGHT HUM.

\*3 Valid when the TYPE is set to LIPS.

\*4 Valid when the TYPE is set to FRETLESS.

## HARMO

Here you can add overtones (harmonics) to the sound specified in the GUITAR block.

Parameter	Value	Explanation
PITCH	-24–+24	Specifies the pitch of the harmonics in semitone units. A setting of -24 produces a sound two octaves below, and a setting of +24 produces a sound two octaves above. With a setting of 0, a harmonics sound at the same pitch as the original sound is heard.
GAIN	0–100	Specifies the volume of the harmonics sound. Larger values increase the volume of the harmonics sound.
ATTACK	0–100	Emphasizes the attack portion of the harmonics sound. Larger values emphasize the attack.
DIRECT LEVEL	0–100	Adjusts the volume of the direct sound. Larger values increase the volume of the direct sound.

## FILTER

Here you can use a filter to add depth to the sound and shape the tonal character.

Parameter	Value	Explanation
OVERTONE	0–100	Modifies the nuances of the overtones. Larger values increase the overtones, giving the sound more depth.
ATTACK	0–100	Varies the nuances of the attack portion. Larger values emphasize the attack.
POWER BEND	0–100	Increasing this value will darken the sound. At the same time, the tone and volume will vary more easily in response to pitch change such as when using the vibrato arm.
SLIDE TIME	0–100	Larger values lengthen the time over which the tone changes from one note to the next on each string, producing an effect of smooth change between notes. At the same time, it tends to suppress the attack.
OCTAVE	-1, 0, +1	Adjusts the center frequency of the filter. A setting of 0 is the normal state, and a setting of -1 applies the filter at a frequency one octave below. A setting of +1 applies the filter at a frequency one octave above.
COLOR	0–100	Modifies the nuances of the overtones. Larger values produce a more detailed sound.
TOUCH SENS	0–100	Specifies how your playing dynamics on the guitar affect the tonal character. With larger values, stronger playing gives the sound more depth.

Parameter	Value	Explanation
LEAD EMPHASIS	0–100	Emphasizes the sound when single notes are played. With VIO guitar, single-note (single-string) playing produces a lower output than when chords are played. Lead emphasis prevents this. Larger values boost the volume level of single notes. With a setting of 0, single notes are not emphasized.

## NS

Refer to “NS” (p. 35).

## EQ

Refer to “EQ” (p. 35).

## POLY FX Parameters

### POLY FX

Parameter	Value	Explanation
<b>TYPE</b>	This selects the POLY FX type.	
	DISTORTION	Distortion that allows chords to resonate clearly and beautifully
	CRYSTAL	A sound with a metallic resonance and a transparent character
	RICH MOD	Rich and spacious modulation sound
	SLOW PAD	Deep, fantasy-like pad-type sound
	TOUCH WAH	You can produce a wah effect with the filter changing in response to the input level.
<b>GUITAR VOLUME</b> *2	0–100	Adjusts the input volume.
<b>BASS VOLUME</b> *2		
<b>GAIN</b> *1	0–100	Adjusts the amount of distortion.
<b>GAIN BALANCE</b> *1	-50+50	Adjusts the distortion balance between the low and high strings. Positive values make the lower strings distort more. Negative values make the higher strings distort more.
<b>COLOR</b> *2	0–100	Specifies the amount of the effect. The effect differs depending on the selected TYPE.
	<b>DISTORTION:</b> Adjusts the amount of separation for chords. Higher settings produce chords less muddy.	
	<b>CRYSTAL:</b> Adjusts the tone for the high frequency range. Higher settings make the tonal character more metallic.	
	<b>RICH MODULATION:</b> Adjusts the depth of the effect. Higher settings make the modulation effect stronger.	
	<b>SLOW PAD:</b> Adjusts the strength of the attack. Higher settings strengthen the attack.	
<b>TONE</b> *2	-50+50	Adjusts the brightness of the sound.
<b>FILTER MODE</b> *3	Selects the wah mode.	
	LPF	Low pass filter. Creates a wah effect over a wide frequency range.
	BPF	Band pass filter. Creates a wah effect in a narrow frequency range.

Parameter	Value	Explanation
<b>POLARITY</b> *3	Selects the direction in which the filter will change in response to the input.	
	DOWN	The frequency of the filter will fall.
	UP	The frequency of the filter will rise.
<b>SENS</b> *3	0–100	Specifies the sensitivity with which the filter moves in the direction specified by the POLARITY setting. Higher values will result in a stronger response. With a setting of 0, the strength of picking will have no effect.
<b>FREQUENCY</b> *3	0–100	Adjusts the center frequency of the Wah effect.
<b>DECAY</b> *3	0–10	This sets the time needed for the filter to finish its sweep.
<b>PEAK</b> *3	0–100	Adjusts the way in which the wah effect applies to the area around the center frequency. Higher values will produce a stronger tone which emphasizes the wah effect more. With a value of 50, a standard wah sound will be produced.
<b>TONE TYPE</b> *3	MILD, STANDARD, BRIGHT	Selects the tone type.
<b>COMP SW</b> *3	OFF, ON	Turns the compressor on/off.
<b>COMP SUSTAIN</b> *3	0–100	Larger values will result in longer sustain.
<b>COMP ATTACK</b> *3	0–100	Adjusts the strength of the picking attack when the strings are played.

\*1 Valid when the TYPE is set to DISTORTION.

\*2 Valid when the TYPE is set to other than TOUCH WAH.

\*3 Valid when the TYPE is set to TOUCH WAH.

## NS

Refer to "NS" (p. 35).

# EFFECT Parameters

## FX1–FX3

With FX1, FX2 and FX3, you can select the effect to be used from the following.

Parameter	Value	Explanation
ON/OFF	OFF, ON	Turns this effect on/off.
TYPE	Refer to FX1/FX2/FX3 TYPE	

## FX1/FX2/FX3 TYPE

This is a list of the effects that can be selected for FX1/FX2/FX3.

Value	Explanation	Page
AC RESONANCE	This processor allows you to change the sound produced by the pickup on an acoustic electric guitar, creating a richer sound similar to that obtained with a microphone placed close to the guitar.	p. 43
AUTO WAH	This changes the filtering over a periodic cycle, providing an automatic wah effect.	p. 43
CHORUS	In this effect, a slightly detuned sound is added to the original sound to add depth and breadth.	p. 43
CLASSIC-VIBE	Although this resembles a phaser effect, it also provides a unique undulation that you can't get with a regular phaser.	p. 44
COMPRESSOR	This is an effect that produces a long sustain by evening out the volume level of the input signal. You can also use it as a limiter to suppress only the sound peaks and prevent distortion.	p. 44
DEFRETTER	This simulates a fretless guitar.	p. 44
DEFRETTER BASS	This simulates a fretless bass.	p. 45
DELAY	Adds delayed sound to the direct sound, giving more body to the sound or creating special effects.	p. 45
FLANGER	The flanging effect gives a twisting, jet-airplane-like character to the sound.	p. 46
FLANGER BASS		
FOOT VOLUME	This is a volume control effect. Typically, you will operate this using an expression pedal connected to the CTL3,4/EXP1 jack or the CTL5,6/EXP2 jack.	p. 46
GRAPHIC EQ	This effect adjusts the tonal character. Seven frequency bands can be adjusted.	p. 47
HARMONIST	Harmonist is an effect where the amount of shifting is adjusted according to an analysis of the guitar input, allowing you to create harmony based on diatonic scales.	p. 47
HUMANIZER	This can create human vowel-like sounds.	p. 48
ISOLATOR	An effect that cuts the sound of the specified region.	p. 48
LIMITER	Attenuates loud input levels to prevent distortion.	p. 48

Value	Explanation	Page
LO-FI	This deliberately degrades the audio quality to create a distinctive impression.	p. 48
OCTAVE	This adds a note one octave lower and a note two octaves lower, creating a richer sound.	p. 49
OCTAVE BASS		
PAN	With the volume level of the left and right sides alternately changing, when playing sound in stereo, you can get an effect that makes the guitar sound appear to fly back and forth between the speakers.	p. 49
PARAMETRIC EQ	This effect adjusts the tonal character. Four frequency bands can be adjusted.	p. 49
PEDAL BEND	This lets you use the pedal to get a pitch bend effect.	p. 49
PHASER	By adding varied-phase portions to the direct sound, the phaser effect gives a whooshing, swirling character to the sound.	p. 50
PITCH SHIFTER	This effect changes the pitch of the original sound (up or down) within a range of two octaves.	p. 50
REVERB	This effect adds reverberation to the sound.	p. 51
RING MOD	This creates a bell-like sound by ring-modulating the guitar sound with the signal from the internal oscillator. The sound can be unmusical and lack distinctive pitches.	p. 51
ROTARY	This produces an effect like the sound of a rotary speaker.	p. 51
SITAR SIM	This simulates the sound of the sitar.	p. 52
SLICER	This consecutively interrupts the sound to create the impression that a rhythm backing phrase is being played.	p. 52
SLOW GEAR	This produces a volume-swell effect ("violin-like" sound).	p. 52
SLOW GEAR BASS		
SOUND HOLD	You can have sound played on the guitar be held continuously. This effect allows you to perform the melody in the upper registers while holding a note in the lower registers.	p. 52
TOUCH WAH	You can produce a wah effect with the filter changing in response to the guitar (bass) level.	p. 53
TOUCH WAH BASS		
TREMOLO	Tremolo is an effect that creates a cyclic change in volume.	p. 53
VIBRATO	This effect creates vibrato by slightly modulating the pitch.	p. 53
WAH	You can control the wah effect in real time by the expression pedal connected to the CTL 3, 4/EXP 1 jack or CTL 5, 6/EXP 2 jack.	p. 54

- **MONO** This effect sound is mono.
- **STEREO** This effect sound is output with two channels.
- **MONO** **STEREO** These effects take a mono input and output it on two channels.

## AC RESONANCE

**MONO**

This processor allows you to change the sound produced by the pickup on an acoustic electric guitar, creating a richer sound similar to that obtained with a microphone placed close to the guitar.

Parameter	Value	Explanation
TYPE	NATURAL	A natural and uncolored sound.
	WIDE	Mellow sound that emphasizes the body resonance
	BRIGHT	Brilliant sound with an extended high-frequency range
RESONANCE	0–100	Use this knob to adjust the balance between the body resonance effect of the acoustic guitar and the direct sound of the pickup.
TONE	-50–+50	Adjusts the tone.
LEVEL	0–100	Specifies the volume of the effect.
VARIATION	PATCH, 01–10	AC RESONANCE settings can be saved/loaded as ten variations.
		A saved VARIATION can be loaded into a different patch, which is convenient when you're creating sounds.

## AUTO WAH

**STEREO**

This changes the filtering over a periodic cycle, providing an automatic wah effect.

Parameter	Value	Explanation
FILTER MODE	Selects the wah mode.	
	LPF	Low pass filter. Passes only the low-frequency region.
	BPF	Band pass filter. Passes only the specified frequency region.
	HPF	High pass filter. Passes only the high-frequency region.
RATE *1	0–100, BPM 	Adjusts the frequency (speed) of the change.
DEPTH	0–100	Adjusts the depth of the effect.
EFFECT LEVEL	0–100	Adjusts the volume of the effect sound.
FREQUENCY	0–100	Adjusts the center frequency of the Wah effect.
RESONANCE	0–100	Adjusts the amount of wah effect applied in the range near the reference frequency.
WAVEFORM	TRI, SINE	Selects the type of wave.
DIRECT LEVEL	0–100	Adjusts the volume of the direct sound.
BPM	40–250	Adjusts the BPM value for each patch.

Parameter	Value	Explanation
VARIATION	PATCH, 01–10	AUTO WAH settings can be saved/loaded as ten variations.
		A saved VARIATION can be loaded into a different patch, which is convenient when you're creating sounds.



\*1 Refer to “About effects when a note value is selected as a setting” (p. 66).

## CHORUS

**MONO** **STEREO** **MONO** **STEREO**

In this effect, a slightly detuned sound is added to the original sound to add depth and breadth.

Parameter	Value	Explanation
MODE	Selection for the chorus mode.	
	MONO <b>MONO</b>	This chorus effect outputs the same sound from both L channel and R channel.
	STEREO1 <b>MONO</b> <b>STEREO</b>	This stereo chorus uses spatial synthesis, with the direct sound output in the L channel and the effect sound output in the R channel.
	STEREO2 <b>STEREO</b>	This is a stereo chorus effect that adds different chorus sounds to L channel and R channel.
	DUAL <b>STEREO</b>	This lets you apply chorus independently to the L and R channels.
RATE *2	0–100, BPM 	Adjusts the rate of the chorus effect.
RATE 1 RATE 2 *1 *2		
DEPTH	0–100	Adjusts the depth of the chorus effect. * To use it for doubling effect, set the value to 0.
DEPTH 1 DEPTH 2 *1		
PRE-DELAY	0.0 ms–40.0 ms	Adjusts the time needed for the effect sound to be output after the direct sound has been output. By setting a longer pre delay time, you can obtain an effect that sounds like more than one sound is being played at the same time (doubling effect).
PRE-DELAY 1 PRE-DELAY 2 *1		
EFFECT LEVEL	0–100	Adjusts the volume of the effect sound.
EFFECT LEVEL 1		
EFFECT LEVEL 2 *1		

Parameter	Value	Explanation
WAVEFORM	TRI	Produces a typical chorus effect. 
WAVEFORM 1 WAVEFORM 2 *1	SINE	Produces a deeper sense of modulation. 
LOW CUT		
LOW CUT 1 LOW CUT 2 *1	FLAT, 20.0 Hz–16.0 kHz	This sets the frequency at which the low cut filter begins to take effect. When FLAT is selected, the low cut filter will have no effect.
HIGH CUT		
HIGH CUT 1 HIGH CUT 2 *1	20.0 Hz–16.0 kHz, FLAT	This sets the frequency at which the high cut filter begins to take effect. When FLAT is selected, the high cut filter will have no effect.
DIRECT LEVEL	0–100	Adjusts the volume of the direct sound. Setting this to 0 cuts the direct sound.
OUTPUT MODE *1	MONO STEREO	This setting is appropriate for mono output. Produces a rich spaciousness when stereo output is used.
BPM	40–250	Adjusts the BPM value for each patch.
VARIATION	PATCH, 01–10	CHORUS settings can be saved/loaded as ten variations. A saved VARIATION can be loaded into a different patch, which is convenient when you're creating sounds.

\*1 Valid when the MODE is set to DUAL.

\*2 Refer to "About effects when a note value is selected as a setting" (p. 66).

## CLASSIC-VIBE

STEREO

Although this resembles a phaser effect, it also provides a unique undulation that you can't get with a regular phaser.

Parameter	Value	Explanation
RATE *1	0–100, BPM 	Adjusts the rate of the effect.
DEPTH	0–100	Adjusts the depth of the effect.
EFFECT LEVEL	0–100	Adjusts the volume.
BPM	40–250	Adjusts the BPM value for each patch.
VARIATION	PATCH, 01–10	CLASSIC-VIBE settings can be saved/loaded as ten variations. A saved VARIATION can be loaded into a different patch, which is convenient when you're creating sounds.

\*1 Refer to "About effects when a note value is selected as a setting" (p. 66).

## COMPRESSOR

STEREO

This is an effect that produces a long sustain by evening out the volume level of the input signal.

Parameter	Value	Explanation
TYPE	BOSS COMP	This models a BOSS CS-3.
	Hi-BAND	A compressor that adds an even stronger effect in the high end.
	LIGHT	A compressor with a light effect.
	D-COMP	This models a MXR DynaComp.
	ORANGE	This is modeled on the sound of the Dan Armstrong ORANGE SQUEEZER.
	FAT	When applied heavily, this compressor effect provides a fat tone with a boosted midrange.
	MILD	When applied heavily, this compressor effect produces a sweet tone with the high end cut.
SUSTAIN	0–100	Adjusts the range (time) over which low-level signals are boosted. Larger values will result in longer sustain.
ATTACK	0–100	Adjusts the strength of the attack when picking.
EFFECT LEVEL	0–100	Adjusts the volume.
TONE	-50–+50	Adjusts the tone.
DIRECT LEVEL	0–100	Adjusts the volume of the direct sound.
VARIATION	PATCH, 01–10	COMPRESSOR settings can be saved/loaded as ten variations. A saved VARIATION can be loaded into a different patch, which is convenient when you're creating sounds.

## DEFRETTER

STEREO

This simulates a fretless guitar.

Parameter	Value	Explanation
SENS	0–100	This controls the input sensitivity of the defretter.
DEPTH	0–100	This controls the volume of the harmonics.
TONE	-50–+50	Adjusts the amount of blurring between the notes.
EFFECT LEVEL	0–100	Adjusts the volume of the effect sound.
ATTACK	0–100	Adjusts the attack of the picking sound.
RESONANCE	0–100	Adds a characteristically resonant quality to the sound.
DIRECT LEVEL	0–100	Adjusts the volume of the direct sound.
VARIATION	PATCH, 01–10	DEFRETTER settings can be saved/loaded as ten variations. A saved VARIATION can be loaded into a different patch, which is convenient when you're creating sounds.

## DEFRETTER BASS

STEREO

This simulates a fretless bass.

Parameter	Value	Explanation
SENS	0–100	This controls the input sensitivity of the defretter.
ATTACK	0–100	Adjusts the attack of the picking sound.
TONE	-50–+50	Adjusts the amount of blurring between the notes.
EFFECT LEVEL	0–100	Adjusts the volume of the effect sound.
DIRECT LEVEL	0–100	Adjusts the volume of the direct sound.
VARIATION	PATCH, 01–10	DEFRETTER BASS settings can be saved/loaded as ten variations. A saved VARIATION can be loaded into a different patch, which is convenient when you're creating sounds.

## DELAY

MONO STEREO MONO &gt; STEREO

Adds delayed sound to the direct sound, giving more body to the sound or creating special effects.

Parameter	Value	Explanation
TYPE	Selects the delay type "TYPE" (p. 46). * The stereo effect is canceled if a mono effect or AMP Modeling is connected after a stereo delay effect.	
TIME *1 *12	1 ms–2000 ms, BPM 	Adjusts the delay time.
D1 TIME D2 TIME *2 *12		
FEEDBACK *3	0–100	This sets the amount of delay sound returned to the input. A higher value will increase the number of the delay repeats.
D1 FEEDBACK D2 FEEDBACK *2		
EFFECT LEVEL *4		
D1 EFFECT LEVEL D2 EFFECT LEVEL *2	0–120	Adjusts the volume of the delay sound.
HIGH CUT *3	20.0 Hz–16.0 kHz, FLAT	This sets the frequency at which the high cut filter begins to take effect. When FLAT is selected, the high cut filter will have no effect.
D1 HIGH CUT D2 HIGH CUT *2		
TAP TIME *6	0–100%	Adjusts the delay time of the right channel delay. This setting adjusts the R channel delay time relative to the L channel delay time (considered as 100%).

Parameter	Value	Explanation
MOD RATE *7	0–100	Adjusts the modulation rate of the delay sound.
MOD DEPTH *7	0–100	Adjusts the modulation depth of the delay sound.
TRIGGER *8	OFF, ON	If this is ON, the WARP effect is applied.
MODE *9	RISE → FALL	Rotation stops when you switch TRIGGER from ON to OFF.
	RISE → FADE	When you switch TRIGGER from ON to OFF, fade-out occurs while continuing the rotation.
TRIGGER *9	OFF, ON	The TWIST effect is applied when you turn this ON.
RISE TIME *9	0–100	This parameter adjusts the amount of time it is to take for the effect to transition to the maximum.
FALL TIME *9 *10	0–100	This parameter adjusts the amount of time it is to take for the effect to transition to the original.
FADE TIME *9 *11	0–100	Adjusts the fade-out time.
DIRECT LEVEL *5	0–100	Adjusts the volume of the direct sound.
CARRY OVER	OFF, ON	Specifies whether the effect sound remains when you turn off the effect, or does not remain.
BPM	40–250	Adjusts the BPM value for each patch.
VARIATION	PATCH, 01–10	DELAY settings can be saved/loaded as ten variations. A saved VARIATION can be loaded into a different patch, which is convenient when you're creating sounds. These variations are shared with the MASTER DELAY setting.

\*1 Valid when the TYPE is set to other than DUAL-S, DUAL-P, DUAL L/R, or TWIST.

\*2 Valid when the TYPE is set to DUAL-S, DUAL-P, or DUAL L/R.

\*3 Valid when the TYPE is set to other than DUAL-S, DUAL-P, DUAL L/R, WARP or TWIST.

\*4 Valid when the TYPE is set to other than DUAL-S, DUAL-P, or DUAL L/R.

\*5 Valid when the TYPE is set to other than WARP or TWIST.

\*6 Valid when the TYPE is set to PAN.

\*7 Valid when the TYPE is set to MOD.

\*8 Valid when the TYPE is set to WARP.

\*9 Valid when the TYPE is set to TWIST.

\*10 Valid when the MODE is set to RISE → FALL.

\*11 Valid when the MODE is set to RISE → FADE.

\*12 Refer to "About effects when a note value is selected as a setting" (p. 66).

TYPE

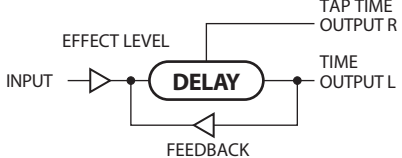
Value	Explanation
STEREO1 <small>MONO STEREO</small>	The direct sound is output from the left channel, and the effect sound is output from the right channel.
STEREO2 <small>STEREO</small>	This is a stereo-in/out delay.
PAN <small>MONO STEREO</small>	This delay is specifically for stereo output. This allows you to obtain the tap delay effect that divides the delay time, then deliver them to L and R channels. 
DUAL-S <small>MONO</small>	This is a delay comprising two different delays connected in series.
DUAL-P <small>MONO</small>	This is a delay comprising two delays connected in parallel.
DUAL-L/R <small>STEREO</small>	This delay lets you specify the L and R channels independently. Delay 1 goes to the left channel, Delay 2 to the right.
REVERSE <small>MONO</small>	This produces an effect where the sound is played back in reverse.
ANALOG <small>STEREO</small>	This gives a mild analog delay sound.
TAPE <small>STEREO</small>	This setting provides the characteristic wavering sound of the tape echo.
MOD <small>STEREO</small>	A delay with a pleasant amount of modulation added.
WARP <small>STEREO</small>	Produces a dream-like sound.
TWIST <small>STEREO</small>	Produces an aggressive sense of rotation. Using this in conjunction with distortion will produce an even wilder sense of rotation.

FLANGER/FLANGER BASS

STEREO

The flanging effect gives a twisting, jet-airplane-like character to the sound.

Parameter	Value	Explanation
RATE *1	0–100, BPM <small>16x11</small> 	This sets the rate of the flanging effect.
DEPTH	0–100	Determines the depth of the flanging effect.
RESONANCE	0–100	Determines the amount of resonance (feedback). Increasing the value will emphasize the effect, creating a more unusual sound.
MANUAL	0–100	Adjusts the center frequency at which to apply the effect.
SEPARATION	0–100	Adjusts the diffusion. The diffusion increases as the value increases.
LOW CUT	FLAT, 20.0 Hz–16.0 kHz	This sets the frequency at which the low cut filter begins to take effect. When FLAT is selected, the low cut filter will have no effect.

Parameter	Value	Explanation
HIGH CUT	20.0 Hz–16.0 kHz, FLAT	This sets the frequency at which the high cut filter begins to take effect. When FLAT is selected, the high cut filter will have no effect.
EFFECT LEVEL	0–100	Adjusts the volume of the flanger.
DIRECT LEVEL	0–100	Adjusts the volume of the direct sound.
BPM	40–250	Adjusts the BPM value for each patch.
VARIATION	PATCH, 01–10	FLANGER and FLANGER BASS settings can be saved/loaded as ten variations. A saved VARIATION can be loaded into a different patch, which is convenient when you're creating sounds.

\*1 Refer to "About effects when a note value is selected as a setting" (p. 66).

FOOT VOLUME

STEREO

This is a volume control effect.

Typically, you will operate this using an expression pedal connected to the CTL3,4/EXP1 jack or the CTL5,6/EXP2 jack.

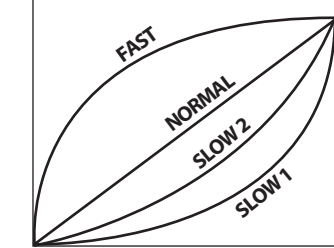
Parameter	Value	Explanation
VOLUME MIN	0–100	Sets the volume when the heel of the EXP Pedal is depressed.
VOLUME MAX	0–100	Selects the volume when the toe of the EXP Pedal is depressed.
VOLUME CURVE	SLOW1, SLOW2, NORMAL, FAST	You can select how the actual volume changes relative to the amount the pedal is pressed. Volume  When the pedal is fully raised      When the pedal is fully advanced
PEDAL POSITION	0–100	Adjusts the volume.
VARIATION	PATCH, 01–10	FOOT VOLUME settings can be saved/loaded as ten variations. A saved VARIATION can be loaded into a different patch, which is convenient when you're creating sounds. The variations are common to FOOT VOLUME 1 and FOOT VOLUME 2.

## GRAPHIC EQ

STEREO

You can adjust the tone character in seven bands.

Parameter	Value	Explanation
LEVEL	-20–+20 dB	Adjusts the overall volume level of the equalizer.
100 Hz	-20–+20 dB	Adjust the volume of each frequency band.
200 Hz		
400 Hz		
800 Hz		
1.6 kHz		
3.2 kHz		
6.4 kHz		
VARIATION	PATCH, 01–10	GRAPHIC EQ settings can be saved/loaded as ten variations. A saved VARIATION can be loaded into a different patch, which is convenient when you're creating sounds.

## HARMONIST

MONO &gt; STEREO MONO

Harmonist is an effect where the amount of shifting is adjusted according to an analysis of the guitar input, allowing you to create harmony based on diatonic scales.

- \* Because of the need to analyze the pitch, chords (two or more sounds played simultaneously) cannot be played. Be sure to mute all the other strings and play only one note at a time.
- \* When you are to play the next string while a certain sound is still playing, mute the previous sound and then play the next one with a clear attack. If the unit cannot detect the attack, it may not sound correctly.
- \* The sensitivity may vary according to the guitar's TONE knob and pickup type.

Parameter	Value	Explanation
VOICE	Selects the number of voices for the pitch shift sound.	
	1VOICE MONO	One-voice pitch-shifted sound output in mono.
	2MONO MONO	Two-voice pitch-shifted sound (HR1, HR2) output in mono.
	2STEREO MONO > STEREO	Two-voice pitch-shifted sound (HR1, HR2) output through left and right channels.
HR1:HARMONY	-2 oct–+2 oct, USER	This determines the pitch of the sound added to the input sound, when you are making a harmony.
HR2:HARMONY *1		It allows you to set it by up to 2 octaves higher or lower than the input sound. When the scale is set to USER, this parameter sets the user scale number to be used.

Parameter	Value	Explanation
KEY	C (Am)–B (G#m)	The key setting corresponds to the key of the song (#, b) as follows.
	Major C F B <sup>b</sup> E <sup>b</sup> A <sup>b</sup> D <sup>b</sup>	
	Minor Am Dm Gm Cm Fm B <sup>b</sup> m	
	Major C G D A E B F <sup>#</sup>	
Minor Am Em Bm F <sup>#</sup> m C <sup>#</sup> m G <sup>#</sup> m D <sup>#</sup> m		
HR1:LEVEL	0–100	Adjusts the volume of the harmony sound.
HR2:LEVEL *1		
HR1:PRE-DELAY *2	0–300 ms, BPM	Adjusts the time from when the direct sound is heard until the harmonist sounds are heard. Normally you can leave this set at 0 ms.
HR2:PRE-DELAY *1 *2		
HR1:FEEDBACK	0–100	Adjusts the feedback amount of the harmonist sound.
DIRECT LEVEL	0–100	Adjusts the volume of the direct sound.
BPM	40–250	Adjusts the BPM value for each patch.
VARIATION	PATCH, 01–10	HARMONIST settings can be saved/loaded as ten variations. A saved VARIATION can be loaded into a different patch, which is convenient when you're creating sounds.

\*1 Valid when the VOICE is set to 2MONO or 2STEREO.

\*2 Refer to "About effects when a note value is selected as a setting" (p. 66).

## USER SCALE

\* Effective with USER selected for HARMONY parameter.

Parameter	Value
C	▼C–▼C–C–▲C–▲C
D <sub>b</sub>	▼D <sub>b</sub> –▼D <sub>b</sub> –D <sub>b</sub> –▲D <sub>b</sub> –▲D <sub>b</sub>
D	▼D–▼D–D–▲D–▲D
E <sub>b</sub>	▼E <sub>b</sub> –▼E <sub>b</sub> –E <sub>b</sub> –▲E <sub>b</sub> –▲E <sub>b</sub>
E	▼E–▼E–E–▲E–▲E
F	▼F–▼F–F–▲F–▲F
F <sub>#</sub>	▼F <sub>#</sub> –▼F <sub>#</sub> –F <sub>#</sub> –▲F <sub>#</sub> –▲F <sub>#</sub>
G	▼G–▼G–G–▲G–▲G
A <sub>b</sub>	▼A <sub>b</sub> –▼A <sub>b</sub> –A <sub>b</sub> –▲A <sub>b</sub> –▲A <sub>b</sub>
A	▼A–▼A–A–▲A–▲A
B <sub>b</sub>	▼B <sub>b</sub> –▼B <sub>b</sub> –B <sub>b</sub> –▲B <sub>b</sub> –▲B <sub>b</sub>
B	▼B–▼B–B–▲B–▲B

The minus (-) and plus (+) symbols indicate sounds above or below the specified original note.

Triangles next to the note names indicate octaves.

One downward-pointing triangle indicates a note one octave below the note displayed; two triangles indicates a two-octave drop.

One upward-pointing triangle indicates a note one octave above the note displayed; two triangles indicates a two-octave rise.

## HUMANIZER

STEREO

This can create human vowel-like sounds.

Parameter	Value	Explanation
MODE	This sets the mode that switches the vowels.	
	PICKING	It changes from VOWEL1 to VOWEL2 along with the picking. The time spent for the change is adjusted with the rate.
	AUTO	By adjusting the rate and depth, two vowels (VOWEL1 and VOWEL2) can be switched automatically.
VOWEL1	a, e, i, o, u	Selects the first vowel.
VOWEL2	a, e, i, o, u	Selects the second vowel.
SENS *1	0–100	Adjusts the sensitivity of the HUMANIZER.
		When it is set to a lower value, no effect of the humanizer is obtained with weaker picking, while stronger picking produces the effect. When it is set to a higher value, the effect of the humanizer can be obtained whether the picking is weak or strong.
RATE *3	0–100, BPM	Adjusts the cycle for changing the two vowels.
DEPTH	0–100	Adjusts the depth of the effect.
MANUAL *2	0–100	This determines the point where the two vowels are switched. When it is set to 50, VOWEL1 and VOWEL2 are switched in the same length of time. When it is set to lower than 50, the time for VOWEL1 is shorter. When it is set to higher than 50, the time for VOWEL1 is longer.
EFFECT LEVEL	0–100	Adjusts the volume.
BPM	40–250	Adjusts the BPM value for each patch.
VARIATION	PATCH, 01–10	HUMANIZER settings can be saved/loaded as ten variations. A saved VARIATION can be loaded into a different patch, which is convenient when you're creating sounds.

\*1 Setting available when MODE is set to PICKING.

\*2 Setting available when MODE is set to AUTO.

\*3 Refer to "About effects when a note value is selected as a setting" (p. 66).

## ISOLATOR

STEREO

An effect that cuts the sound of the specified region.

Parameter	Value	Explanation
BAND	LOW, MIDDLE, HIGH	Selects the frequency region to cut.
RATE *1	0–100, BPM	Adjusts the rate of the modulation.
DEPTH	0–100	Adjusts the depth of the modulation.
BAND LEVEL	0–100	Specifies the amount to cut.

Parameter	Value	Explanation
BPM	40–250	Adjusts the BPM value for each patch.
VARIATION	PATCH, 01–10	ISOLATOR settings can be saved/loaded as ten variations. A saved VARIATION can be loaded into a different patch, which is convenient when you're creating sounds.

\*1 Refer to "About effects when a note value is selected as a setting" (p. 66).

## LIMITER

STEREO

Attenuates loud input levels to prevent distortion.

Parameter	Value	Explanation
TYPE	Selects the limiter type.	
	BOSS LIMITER	Selects a stereo limiter.
	RACK 160D	Models a dbx 160X.
	VTG RACK U	Models an UREI 1178.
THRESHOLD	0–100	Adjust this as appropriate for the input signal. When the input signal level exceeds this threshold level, compression will be applied.
RATIO	1:1, 1.2:1, 1.4:1, 1.6:1, 1.8:1, 2:1, 2.3:1, 2.6:1, 3:1, 3.5:1, 4:1, 5:1, 6:1, 8:1, 10:1, 12:1, 20:1, INF:1	Selects the compression ratio used with signals in excess of the threshold level.
EFFECT LEVEL	0–100	Adjusts the volume.
ATTACK	0–100	Adjusts the strength of the attack when picking. Higher values result in sharper attack, creating a more clearly defined sound.
RELEASE	0–100	Adjusts the release time.
VARIATION	PATCH, 01–10	LIMITER settings can be saved/loaded as ten variations. A saved VARIATION can be loaded into a different patch, which is convenient when you're creating sounds.

## LO-FI

STEREO

This deliberately degrades the audio quality to create a distinctive impression.

Parameter	Value	Explanation
BIT DEPTH	OFF, 15–1	Specifies the bit depth.
SAMPLE RATE	OFF, 1/2–1/32	Specifies the sample rate.
BALANCE	D100:E0–D0:E100	Adjusts the volume balance between the direct sound and the effect sound.

Parameter	Value	Explanation
VARIATION	PATCH, 01–10	LO-FI settings can be saved/loaded as ten variations. A saved VARIATION can be loaded into a different patch, which is convenient when you're creating sounds.

## OCTAVE/OCTAVE BASS

MONO

This adds a note one octave lower and a note two octaves lower, creating a richer sound.

Parameter	Value	Explanation
-2OCT	0–100	Adjusts the volume of the sound two octaves below.
-1OCT	0–100	Adjusts the volume of the sound one octave below.
DIRECT LEVEL	0–100	Adjusts the volume of the direct sound.
VARIATION	PATCH, 01–10	OCTAVE and OCTAVE BASS settings can be saved/loaded as ten variations. A saved VARIATION can be loaded into a different patch, which is convenient when you're creating sounds.

## PAN

STEREO

With the volume level of the left and right sides alternately changing, when playing sound in stereo, you can get an effect that makes the guitar sound appear to fly back and forth between the speakers.

Parameter	Value	Explanation
TYPE	AUTO	Varies the volume level on the left and right according to the settings for WAVE SHAPE, RATE, and DEPTH.
	MANUAL	Output uses the volume balance set with POSITION.
WAVE SHAPE *1	0–100	Adjusts changes in volume level. A higher value will steepen wave's shape.
RATE *1 *3	0–100, BPM 	Adjusts the frequency (speed) of the change.
DEPTH *1	0–100	Adjusts the depth of the effect.
EFFECT LEVEL	0–100	Adjusts the volume.
POSITION *2	L50–CENTER–R50	Adjusts the volume balance between the left and right channels.
BPM	40–250	Adjusts the BPM value for each patch.
VARIATION	PATCH, 01–10	PAN settings can be saved/loaded as ten variations. A saved VARIATION can be loaded into a different patch, which is convenient when you're creating sounds.

\*1 Setting available when TYPE is set to AUTO.

\*2 Setting available when TYPE is set to MANUAL.

\*3 Refer to "About effects when a note value is selected as a setting" (p. 66).

## PARAMETRIC EQ

STEREO

You can adjust the tone character in four bands.

Parameter	Value	Explanation
LOW CUT	FLAT, 20.0 Hz–16.0 kHz	This sets the frequency at which the low cut filter begins to take effect. When FLAT is selected, the low cut filter will have no effect.
LOW GAIN	-20–+20 dB	Adjusts the tone for the low frequency range.
LOW-MID FREQ	20.0 Hz–16.0 kHz	Specifies the center of the frequency range that will be adjusted by the LOW-MID GAIN.
LOW-MID Q	0.5–16	Adjusts the width of the area affected by the EQ centered at the LOW-MID FREQ. Higher values will narrow the area.
LOW-MID GAIN	-20–+20 dB	Adjusts the low-middle frequency range tone.
HIGH-MID FREQ	20.0 Hz–16.0 kHz	Specifies the center of the frequency range that will be adjusted by the HIGH-MID GAIN.
HIGH-MID Q	0.5–16	Adjusts the width of the area affected by the EQ centered at the HIGH-MID FREQ. Higher values will narrow the area.
HIGH-MID GAIN	-20–+20 dB	Adjusts the high-middle frequency range tone.
HIGH GAIN	-20–+20 dB	Adjusts the tone for the high frequency range.
HIGH CUT	20.0 Hz–16.0 kHz, FLAT	This sets the frequency at which the high cut filter begins to take effect. When FLAT is selected, the high cut filter will have no effect.
LEVEL	-20–+20 dB	Adjusts the overall volume level of the equalizer.
VARIATION	PATCH, 01–10	PARAMETRIC EQ settings can be saved/loaded as ten variations. A saved VARIATION can be loaded into a different patch, which is convenient when you're creating sounds. These variations are shared with the EQ1 and EQ2 block setting.

## PEDAL BEND

MONO

This lets you use the pedal to get a pitch bend effect.

Typically, you will operate this using an expression pedal connected to the CTL3,4/EXP1 jack or the CTL5,6/EXP2 jack.

\* Because of the need to analyze the pitch, chords (two or more sounds played simultaneously) cannot be played.



Parameter	Value	Explanation
PITCH	-24–+24	This sets the pitch at the point where the EXP Pedal is all the way down.
PEDAL POSITION	0–100	Adjusts the pedal position for pedal bend. This parameter is used after it's been assigned to an expression pedal or similar controller.

Parameter	Value	Explanation
EFFECT LEVEL	0–100	Adjusts the volume of the pitch bend sound.
DIRECT LEVEL	0–100	Adjusts the volume of the direct sound.
VARIATION	PATCH, 01–10	PEDAL BEND settings can be saved/loaded as ten variations. A saved VARIATION can be loaded into a different patch, which is convenient when you're creating sounds.

## PHASER

STEREO

By adding varied-phase portions to the direct sound, the phaser effect gives a whooshing, swirling character to the sound.





Parameter	Value	Explanation
TYPE	4STAGE, 8STAGE, 12STAGE, BiPHASE	Selects the number of stages that the phaser effect will use.
RATE *1	0–100, BPM 	This sets the rate of the phaser effect.
DEPTH	0–100	Determines the depth of the phaser effect.
RESONANCE	0–100	Determines the amount of resonance (feedback). Increasing the value will emphasize the effect, creating a more unusual sound.
MANUAL	0–100	Adjusts the center frequency of the phaser effect.
STEP RATE *1	OFF, 0–100, BPM 	This sets the cycle of the step function that changes the rate and depth. When it is set to a higher value, the change will be finer. Set this to "Off" when not using the Step function.
EFFECT LEVEL	0–100	Adjusts the volume of the phaser.
DIRECT LEVEL	0–100	Adjusts the volume of the direct sound.
BPM	40–250	Adjusts the BPM value for each patch.
VARIATION	PATCH, 01–10	PHASER settings can be saved/loaded as ten variations. A saved VARIATION can be loaded into a different patch, which is convenient when you're creating sounds.

\*1 Refer to "About effects when a note value is selected as a setting" (p. 66).

## PITCH SHIFTER

MONO > STEREO MONO

This effect changes the pitch of the original sound (up or down) within a range of two octaves.

Parameter	Value	Explanation
VOICE	1VOICE 	Selects the number of voices for the pitch shift sound. One-voice pitch-shifted sound output in mono.
	2MONO 	Two-voice pitch-shifted sound (PS1, PS2) output in mono.
	2STEREO 	Two-voice pitch-shifted sound (PS1, PS2) output through left and right channels.
PS1:PITCH	-24–+24	Adjusts the amount of pitch shift (the amount of interval) in semitone steps.
PS2:PITCH *1		
DIRECT LEVEL	0–100	Adjusts the volume of the direct sound.
PS1:MODE	Selection for the pitch shifter mode.	
	FAST, MEDIUM, SLOW	The response is slower in the order of FAST, MEDIUM, and SLOW, but the modulation is lessened in the same order.
PS2:MODE *1	MONO	MONO is used for inputting single notes. You may be unable to produce the intended effect when playing chords (two or more notes played simultaneously).
PS1:FINE	-50–+50	Make fine adjustments to the interval. The amount of the change in the FINE 100 is equivalent to that of the PITCH 1.
PS2:FINE *1		
PS1:PRE-DELAY *2	0 ms–300 ms, BPM 	Adjusts the time from when the direct sound is heard until the pitch shifted sounds are heard. Normally you can leave this set at 0ms.
PS2:PRE-DELAY *1 *2		
PS1:LEVEL	0–100	Adjusts the volume of the pitch shifter.
PS2:LEVEL *1		
PS1:FEEDBACK	0–100	Adjusts the feedback amount of the pitch shift sound.
BPM	40–250	Adjusts the BPM value for each patch.
VARIATION	PATCH, 01–10	PITCH SHIFTER settings can be saved/loaded as ten variations. A saved VARIATION can be loaded into a different patch, which is convenient when you're creating sounds.

\*1 Valid when the VOICE is set to 2MONO or 2STEREO.

\*2 Refer to "About effects when a note value is selected as a setting" (p. 66).

## REVERB

MONO  
STEREO

This effect adds reverberation to the sound.

Parameter	Value	Explanation
TYPE	This selects the reverb type. Various different simulations of space are offered.	
	AMBIENCE	Simulates an ambience mic (off-mic, placed at a distance from the sound source) used in recording and other applications. Rather than emphasizing the reverberation, this reverb is used to produce a sense of openness and depth.
	ROOM	Simulates the reverberation in a small room. Provides warm reverberations.
	HALL1	Simulates the reverberation in a concert hall. Provides clear and spacious reverberations.
	HALL2	Simulates the reverberation in a concert hall. Provides mild reverberations.
	PLATE	Simulates plate reverberation (a reverb unit that uses the vibration of a metallic plate). Provides a metallic sound with a distinct upper range.
	SPRING	This simulates the sound of a guitar amp's built-in spring reverb.
	MOD	This reverb adds the wavering sound found in hall reverb to provide an extremely pleasant reverb sound.
TIME	0.1 s–10.0 s	Adjusts the length (time) of reverberation.
PRE-DELAY	0 ms–500 ms	Adjusts the time until the reverb sound appears.
EFFECT LEVEL	0–100	Adjusts the volume of the reverb sound.
LOW CUT	FLAT, 20.0 Hz–16.0 kHz	This sets the frequency at which the low cut filter begins to take effect. When FLAT is selected, the low cut filter will have no effect.
HIGH CUT	20.0 Hz–16.0 kHz, FLAT	This sets the frequency at which the high cut filter begins to take effect. When FLAT is selected, the high cut filter will have no effect.
DENSITY	1–10	Adjusts the density of the reverb sound.
DIRECT LEVEL	0–100	Adjusts the volume of the direct sound.
CARRY OVER	OFF, ON	Specifies whether the effect sound remains when you turn off the effect, or does not remain.
SPRING SENS *1	0–100	Adjusts the sensitivity of the spring effect. When the value is set higher, the effect is obtained even with a weak picking.
VARIATION	PATCH, 01–10	REVERB settings can be saved/loaded as ten variations. A saved VARIATION can be loaded into a different patch, which is convenient when you're creating sounds.

\*1 Valid when the TYPE is set to SPRING.

## RING MOD

STEREO

This creates a bell-like sound by ring-modulating the guitar sound with the signal from the internal oscillator. The sound can be unmusical and lack distinctive pitches.



Parameter	Value	Explanation
INTELLIGENT	OFF, ON	If this is ON, the oscillator frequency changes according to the pitch of the input sound, producing a pitched sound. In this case, the expected effect does not occur if the pitch of the guitar sound is not detected correctly. We recommend that you use this with single-note playing.
FREQUENCY	0–100	Adjusts the frequency of the internal oscillator.
FREQ MOD RATE *1	0–100, BPM 	Adjusts the rate at which the internal oscillator is modulated.
FREQ MOD DEPTH	0–100	Adjusts the depth to which the internal oscillator is modulated.
EFFECT LEVEL	0–100	Adjusts the volume of the effect sound.
DIRECT LEVEL	0–100	Adjusts the volume of the direct sound.
BPM	40–250	Adjusts the BPM value for each patch.
VARIATION	PATCH, 01–10	RING MOD settings can be saved/loaded as ten variations. A saved VARIATION can be loaded into a different patch, which is convenient when you're creating sounds.

\*1 Refer to "About effects when a note value is selected as a setting" (p. 66).

## ROTARY

MONO  
STEREO

This produces an effect like the sound of a rotary speaker.

Parameter	Value	Explanation
SPEED SELECT	SLOW, FAST	This parameter changes the simulated speaker's rotating speed (SLOW or FAST).
RATE SLOW *1	0–100, BPM 	This parameter adjusts the rotation speed when SPEED SELECT is set to "SLOW."
RATE FAST *1	0–100, BPM 	This parameter adjusts the rotation speed when SPEED SELECT is set to "FAST."
DEPTH	0–100	Adjusts the amount of depth in the rotary effect.
RISE TIME	0–100	This parameter adjusts the time it takes for the rotation SPEED SELECT to change when switched from "SLOW" to "FAST."
FALL TIME	0–100	This parameter adjusts the time it takes for the rotation SPEED SELECT to change when switched from "FAST" to "SLOW."
EFFECT LEVEL	0–100	Adjusts the volume.
DIRECT LEVEL	0–100	Adjusts the volume of the direct sound.

Parameter	Value	Explanation
BPM	40–250	Adjusts the BPM value for each patch.
VARIATION	PATCH, 01–10	ROTARY settings can be saved/loaded as ten variations. A saved VARIATION can be loaded into a different patch, which is convenient when you're creating sounds.

\*1 Refer to "About effects when a note value is selected as a setting" (p. 66).

## SITAR SIM

STEREO

This simulates the sound of the sitar.

Parameter	Value	Explanation
SENS	0–100	Adjusts the sensitivity of the sitar. When it is set to a lower value, no effect of the sitar is obtained with weaker picking, while stronger picking produces the effect. When it is set to a higher value, the effect of the sitar can be obtained whether the picking is weak or strong.
DEPTH	0–100	This adjusts the amount of effect applied.
TONE	-50+50	Adjusts the tone character. The high end is boosted as the value increases.
EFFECT LEVEL	0–100	Adjust the volume of the sitar sound.
RESONANCE	0–100	This adjusts the undulation of the resonance.
BUZZ	0–100	Adjusts the amount of characteristic buzz produced by the "buzz bridge" when the strings make contact with it.
DIRECT LEVEL	0–100	Adjusts the volume of the direct sound.
VARIATION	PATCH, 01–10	SITAR SIM settings can be saved/loaded as ten variations. A saved VARIATION can be loaded into a different patch, which is convenient when you're creating sounds.

## SLICER

STEREO

This consecutively interrupts the sound to create the impression that a rhythm backing phrase is being played.

Parameter	Value	Explanation
PATTERN	P1–P20	Select the slice pattern (rhythm) that will be used to cut the sound.
RATE *1	0–100, BPM 	Adjust the rate at which the sound will be cut.
TRIGGER	OFF, ON	When you switch this from OFF to ON, the slice pattern (rhythm) returns to its beginning. * Patches are written with the TRIGGER parameter set to Off.

Parameter	Value	Explanation
EFFECT LEVEL	0–100	Adjusts the volume of the effect sound.
ATTACK	0–100	Adjusts the volume of the attacks for the slice pattern (rhythm).
DUTY	1–99	Adjusts the duration of the sound for the slice pattern (rhythm).
DIRECT LEVEL	0–100	Adjusts the volume of the direct sound.
BPM	40–250	Adjusts the BPM value for each patch.
VARIATION	PATCH, 01–10	SLICER settings can be saved/loaded as ten variations. A saved VARIATION can be loaded into a different patch, which is convenient when you're creating sounds.

\*1 Refer to "About effects when a note value is selected as a setting" (p. 66).

## SLOW GEAR/SLOW GEAR BASS

STEREO

This produces a volume-swell effect ("violin-like" sound).

Parameter	Value	Explanation
SENS	0–100	Adjusts the sensitivity of the slow gear. When it is set to a lower value, the effect of the slow gear can be obtained only with a stronger picking, while no effect is obtained with a weaker picking. When the value is set higher, the effect is obtained even with a weak picking.
RISE TIME	0–100	Adjusts the time needed for the volume to reach its maximum from the moment you begin picking.
LEVEL	0–100	Adjusts the volume of the effect sound.
VARIATION	PATCH, 01–10	SLOW GEAR and SLOW GEAR BASS settings can be saved/loaded as ten variations. A saved VARIATION can be loaded into a different patch, which is convenient when you're creating sounds.

## SOUND HOLD

STEREO

You can have sound played on the guitar be held continuously. This effect allows you to perform the melody in the upper registers while holding a note in the lower registers.

\* This function will not work properly when two or more notes are played simultaneously.

Parameter	Value	Explanation
TRIGGER	OFF, ON	Switches the hold sound on and off. Normally, this is controlled with the CTL pedals. • It is assumed that this parameter will be assigned to the footswitch. • Patches are written with the TRIGGER parameter set to Off.

Parameter	Value	Explanation
RISE TIME	0–100	Adjusts how rapidly the Sound Hold sound is produced.
EFFECT LEVEL	0–120	Adjusts the volume of the hold sound.
VARIATION	PATCH, 01–10	SOUND HOLD settings can be saved/loaded as ten variations. A saved VARIATION can be loaded into a different patch, which is convenient when you're creating sounds.

## TOUCH WAH/TOUCH WAH BASS

STEREO

You can produce a wah effect with the filter changing in response to the guitar/bass level.

Parameter	Value	Explanation
FILTER MODE		Selects the wah mode.
	LPF	Low pass filter. Passes only the low-frequency region.
	BPF	Band pass filter. Passes only the specified frequency region.
	HPF	High pass filter. Passes only the high-frequency region.
POLARITY		Selects the direction in which the filter will change in response to the input.
	DOWN	The frequency of the filter will fall.
	UP	The frequency of the filter will rise.
SENS	0–100	Specifies the sensitivity with which the filter moves in the direction specified by the POLARITY setting. Higher values will result in a stronger response. With a setting of 0, the strength of picking will have no effect.
FREQUENCY	0–100	Adjusts the center frequency of the Wah effect.
RESONANCE	0–100	Adjusts the amount of wah effect applied in the range near the reference frequency. Higher values will produce a stronger tone which emphasizes the wah effect more. With a value of 50, a standard wah sound will be produced.
DECAY	0–100	Adjusts the rate at which the filter is moved.
EFFECT LEVEL	0–100	Adjusts the volume of the effect sound.
DIRECT LEVEL	0–100	Adjusts the volume of the direct sound.
VARIATION	PATCH, 01–10	TOUCH WAH and TOUCH WAH BASS settings can be saved/loaded as ten variations. A saved VARIATION can be loaded into a different patch, which is convenient when you're creating sounds.

## TREMOLO

STEREO

Tremolo is an effect that creates a cyclic change in volume.

Parameter	Value	Explanation
WAVE SHAPE	0–100	Adjusts changes in volume level. A higher value will steepen wave's shape.
RATE *1	0–100, BPM 	Adjusts the frequency (speed) of the change.
DEPTH	0–100	Adjusts the depth of the effect.
EFFECT LEVEL	0–100	Adjusts the volume.
DIRECT LEVEL	0–100	Adjusts the volume of the direct sound.
BPM	40–250	Adjusts the BPM value for each patch.
VARIATION	PATCH, 01–10	TREMOLO settings can be saved/loaded as ten variations. A saved VARIATION can be loaded into a different patch, which is convenient when you're creating sounds.

\*1 Refer to "About effects when a note value is selected as a setting" (p. 66).

## VIBRATO

STEREO

This effect creates vibrato by slightly modulating the pitch.

Parameter	Value	Explanation
RATE *1	0–100, BPM 	Adjusts the rate of the vibrato.
DEPTH	0–100	Adjusts the depth of the vibrato.
TRIGGER	OFF, ON	This selects on/off of the vibrato.
RISE TIME	0–100	This sets the time passing from the moment the Trigger is turned on until the set vibrato is obtained.
EFFECT LEVEL	0–100	Adjusts the volume.
DIRECT LEVEL	0–100	Adjusts the volume of the direct sound.
BPM	40–250	Adjusts the BPM value for each patch.
VARIATION	PATCH, 01–10	VIBRATO settings can be saved/loaded as ten variations. A saved VARIATION can be loaded into a different patch, which is convenient when you're creating sounds.

\*1 Refer to "About effects when a note value is selected as a setting" (p. 66).

## WAH

STEREO

You can control the wah effect in real time by the expression pedal.

Parameter	Value	Explanation
TYPE	Selects the type of wah.	
	CRY WAH	This models the sound of the CRY BABY wah pedal popular in the '70s.
	VO WAH	Models the VOX V846.
	FAT WAH	This is a wah sound featuring a bold tone.
	LIGHT WAH	This wah has a refined sound with no unusual characteristics.
	7STRING WAH	This expanded wah features a variable range compatible with seven-string and baritone guitars.
	RESO WAH	This completely original effect offers enhancements on the characteristic resonances produced by analog synth filters.
	BASS WAH	This wah has been specially adapted for use in the bass registers. Inclusion of the low-frequency range in the wah sound produces a robust wah effect, with no dilution of the sound.
PEDAL POSITION	0–100	Adjusts the position of the wah pedal. * This parameter is used after it's been assigned to an expression pedal or similar controller.
PEDAL MIN	0–100	Selects the tone produced when the heel of the EXP Pedal is depressed.
PEDAL MAX	0–100	Selects the tone produced when the toe of the EXP Pedal is depressed.
EFFECT LEVEL	0–100	Adjusts the volume of the effect sound.
DIRECT LEVEL	0–100	Adjusts the volume of the direct sound.
VARIATION	PATCH, 01–10	WAH settings can be saved/loaded as ten variations. A saved VARIATION can be loaded into a different patch, which is convenient when you're creating sounds.

## AMP (AMP Modeling)

MONO

Simulates the response of the preamp, the size of the speakers, and the type of cabinet.

Parameter	Value	Explanation
ON/OFF	OFF, ON	Turns this effect on/off.
TYPE	Selects the AMP type "TYPE" (p. 55).	
GAIN	0–120	Adjusts the distortion of the amp.
SAG	-10–+10	Adjusts the amount by which compression changes in response to the power amp.
RESONANCE	-10–+10	Adjusts the amount by which dynamics is affected by the interaction between the power amp and the speaker transformer.
LEVEL	0–100	Adjusts the volume of the entire preamp. * Be careful not to raise the LEVEL setting too high.
BASS	0–100	Adjusts the tone for the low frequency range.
MIDDLE	0–100	Adjusts the tone for the middle frequency range.
TREBLE	0–100	Adjusts the tone for the high frequency range.
PRESENCE	0–100	Adjusts the tone for the ultra high frequency range.
BRIGHT	OFF, ON	Turns the bright setting on/off. * BRIGHT is valid for some of the amps in TYPE.
GAIN SW	LOW, MIDDLE, HIGH	Provides for selection from three levels of distortion: LOW, MIDDLE, and HIGH. Distortion will successively increase for settings of LOW, MIDDLE and HIGH. * The sound of each Type is created on the basis that the Gain is set to MIDDLE.
SOLO SW	OFF, ON	Switches the tone to one suitable for solos.
SOLO LEVEL	0–100	Adjusts the volume level when the SOLO SW is ON.
SP TYPE	This setting selects the simulated speaker type "SP TYPE" (p. 55).	
MIC TYPE	This setting selects the simulated mic type "MIC TYPE" (p. 55).	
MIC DISTANCE	SHORT, MEDIUM, LONG	Simulates the distance between the mic and speaker. The distance from the speakers is farther in the order of SHORT<MEDIUM<LONG.
	This simulates the mic position.	
MIC POSITION	CENTER	Simulates the condition that the mic is set in the middle of the speaker cone.
	1 cm–10 cm	Simulates the condition that the mic is moved away from the center of the speaker cone.
MIC LEVEL	0–100	Adjusts the volume of the mic.
DIRECT LEVEL	0–100	Adjusts the volume of the direct sound.

Parameter	Value	Explanation
VARIATION	PATCH, 01–10	<p>AMP Modeling settings can be saved/loaded as ten variations.</p> <p>A saved VARIATION can be loaded into a different patch, which is convenient when you're creating sounds.</p> <p>The variations are common to AMP Modeling (when E.GUITAR, E.BASS, ACOUSTIC, or AC BASS is selected) within the INST.</p>

## TYPE

Value	Explanation
TRANSPARENT	An amp with a broad frequency range and an extremely flat response. Good for acoustic guitar.
NATURAL	An unembellished, clean sound that minimizes the amp's idiosyncrasies, such as its trebly character and boomy low end.
BOUTIQUE	Crunch sound that allows the nuances of your picking to be expressed even more faithfully than on conventional combo amps.
SUPREME	Great-feeling crunch sound that responds to the nuances of your picking while taking advantage of the distinctive character of a 4x12" speaker cabinet.
MAXIMUM	An amp that delivers the distinctively great response and tone of a vintage Marshall, while making it even higher gain.
JUGGERNAUT	A large stack sound that has been tweaked extensively in the pursuit of the ultimate metal sound.
X-CRUNCH	Crunch sound that uses MDP to deliver a crisp tone from all strings.
X-HI GAIN	High-gain sound that uses MDP to obtain high-gain sound with a wide range and a great-feeling sense of separation.
X-MODDED	Core sound that uses MDP to preserve the definition of the sound even with extreme gain.
JC-120	This models the sound of the Roland JC-120.
TWIN COMBO	This models a Fender Twin Reverb.
DELUXE COMBO	This models a Fender Deluxe Reverb.
TWEED COMBO	This models a Fender Bassman 4x10" Combo.
DIAMOND AMP	This models a VOX AC30.
BRIT STACK	This models a Marshall 1959.
RECTI STACK	Models the sound of the Channel 2 MODERN Mode on the MESA/Boogie DUAL Rectifier.
MATCH COMBO	This models the sound input to left input on a Matchless D/C-30.
BG COMBO	This models the sound of the MESA/Boogie combo amp.
ORNG STACK	This models the dirty channel of an ORANGE ROCKERVERB.
BG NR UB METAL	This models the sound that models the high-gain channel of a Bogner Uberschall.
NATURAL BASS	Uncolored clean sound for bass.
X-DRIVE BASS	High-gain sound for bass, using MDP to provide wide range and a good-sounding sense of separation.

Value	Explanation
CONCERT	This models the Ampeg SVT.
SUPER FLAT	A bass amp with flat response.
FLIP TOP	Models the Ampeg B-15.
B MAN	Models the Fender Bassman 100.
BASS 360	Models the Acoustic 360.
SW-TOUR	Models the SWR SM-400.
AC BASS	An amp ideal for ACOUSTIC BASS.
GK BASS	Models the Gallien-Krueger 800RB.
MARK	Models the Markbass Little Mark III.

## SP TYPE

Value	Explanation
OFF	This turns off the speaker simulator.
ORIGINAL	This is the built-in speaker of the amp you selected with PREAMP TYPE.
1x8"	This is a compact open-back speaker cabinet with one 8-inch speaker.
1x10"	This is a compact open-back speaker cabinet with one 10-inch speaker.
1x12"	This is a compact open-back speaker cabinet with one 12-inch speaker.
2x12"	This is a general open-back speaker cabinet with two 12-inch speakers.
4x10"	This is a large closed-back speaker cabinet with four 10-inch speakers.
4x12"	This is a large closed-back speaker cabinet with four 12-inch speakers.
8x12"	This is a stack of two cabinets each with four 12-inch speakers.
B1x15"	This is a compact open-back speaker cabinet for the bass guitar with one 15-inch speaker.
B1x18"	This is a compact open-back speaker cabinet for the bass guitar with one 18-inch speaker.
B2x15"	This is a general open-back speaker cabinet for the bass guitar with two 15-inch speakers.
B4x10"	This is a large closed-back speaker cabinet for the bass guitar with four 10-inch speakers.
B8x10"	This is a stack of two cabinets for bass, each with four 10-inch speakers.

## MIC TYPE

Value	Explanation
DYN57	This is the sound of the SHURE SM57. General dynamic mic used for instruments and vocals.
DYN421	This is the sound of the SENNHEISER MD-421. Dynamic mic with extended low end.
CND451	This is the sound of the AKG C451B. Small condenser mic for use with instruments.
CND87	This is the sound of the NEUMANN U87. Condenser mic with flat response.
FLAT	Simulates a mic with perfectly flat response. Produces a sonic image close to that of listening to the sound directly from the speakers (on site).

# CHORUS



In this effect, a slightly detuned sound is added to the original sound to add depth and breadth.

Parameter	Value	Explanation
ON/OFF	OFF, ON	Turns this effect on/off.
MODE	Selection for the chorus mode.	
	MONO	This chorus effect outputs the same sound from both L channel and R channel.
	STEREO1	This stereo chorus uses spatial synthesis, with the direct sound output in the L channel and the effect sound output in the R channel.
	STEREO2	This is a stereo chorus effect that adds different chorus sounds to L channel and R channel.
	DUAL	This lets you apply chorus independently to the L and R channels.
RATE *2		
RATE 1 RATE 2 *1 *2	0–100, BPM	Adjusts the rate of the chorus effect.
DEPTH		
DEPTH 1 DEPTH 2 *1	0–100	Adjusts the depth of the chorus effect. * To use it for doubling effect, set the value to 0.
PRE-DELAY		
PRE-DELAY 1 PRE-DELAY 2 *1	0.0 ms–40.0 ms	Adjusts the time needed for the effect sound to be output after the direct sound has been output. By setting a longer pre delay time, you can obtain an effect that sounds like more than one sound is being played at the same time (doubling effect).
EFFECT LEVEL		
EFFECT LEVEL 1 EFFECT LEVEL 2 *1	0–100	Adjusts the volume of the effect sound.
WAVEFORM		Produces a typical chorus effect.
WAVEFORM 1 WAVEFORM 2 *1	TRI	Produces a deeper sense of modulation.
LOW CUT		
LOW CUT 1 LOW CUT 2 *1	FLAT, 20.0 Hz–16.0 kHz	This sets the frequency at which the low cut filter begins to take effect. When FLAT is selected, the low cut filter will have no effect.

Parameter	Value	Explanation
HIGH CUT		
HIGH CUT 1 HIGH CUT 2 *1	20.0 Hz–16.0 kHz, FLAT	This sets the frequency at which the high cut filter begins to take effect. When FLAT is selected, the high cut filter will have no effect.
DIRECT LEVEL	0–100	Adjusts the volume of the direct sound. Setting this to 0 cuts the direct sound.
OUTPUT MODE *1	MONO STEREO	This setting is appropriate for mono output. Produces a rich spaciousness when stereo output is used.
BPM	40–250	Adjusts the BPM value for each patch.
VARIATION	PATCH, 01–10	CHORUS settings can be saved/loaded as ten variations. A saved VARIATION can be loaded into a different patch, which is convenient when you're creating sounds. These variations are shared with the CHORUS setting in FX1–FX3.

\*1 Valid when the MODE is set to DUAL.

\*2 Refer to "About effects when a note value is selected as a setting" (p. 66).

## COMPRESSOR

STEREO

This is an effect that produces a long sustain by evening out the volume level of the input signal.

Parameter	Value	Explanation
ON/OFF	OFF, ON	Turns this effect on/off.
TYPE		Selects the compressor type "TYPE" (p. 57).
SUSTAIN	0–100	Adjusts the range (time) over which low-level signals are boosted. Larger values will result in longer sustain.
ATTACK	0–100	Adjusts the strength of the attack when picking.
EFFECT LEVEL	0–100	Adjusts the volume.
DIRECT LEVEL	0–100	Adjusts the volume of the direct sound.
tone	-50+50	Adjusts the tone character.
VARIATION	PATCH, 01–10	COMPRESSOR settings can be saved/loaded as ten variations. A saved VARIATION can be loaded into a different patch, which is convenient when you're creating sounds. These variations are shared with the COMPRESSOR setting in FX1–FX3.

### TYPE

Value	Explanation
BOSS COMP	This models a BOSS CS-3.
Hi-BAND	A compressor that adds an even stronger effect in the high end.
LIGHT	A compressor with a light effect.
D-COMP	This models a MXR DynaComp.
ORANGE	This is modeled on the sound of the Dan Armstrong ORANGE SQUEEZER.
FAT	When applied heavily, this compressor effect provides a fat tone with a boosted midrange.
MILD	When applied heavily, this compressor effect produces a sweet tone with the high end cut.

## DISTORTION

MONO

This effect distorts the sound to create long sustain.

Parameter	Value	Explanation
ON/OFF	OFF, ON	Turns this effect on/off.
TYPE		Selects the DISTORTION type "TYPE" (p. 57).
DRIVE	0–120	Adjusts the depth of distortion.
tone	-50+50	Adjusts the tone.
LEVEL	0–100	Adjusts the volume of the effect sound.
BOTTOM	-50+50	Adjusts the tone for the low frequency range. Turning this to the left (counterclockwise) produces a sound with the low end cut; turning it to the right boosts the low end in the sound.
DIRECT LEVEL	0–100	Adjusts the volume of the direct sound.
SOLO SW	OFF, ON	Switches the tone to one suitable for solos.
SOLO LEVEL	0–100	Adjusts the volume level when the SOLO SW is ON.
VARIATION	PATCH, 01–10	DISTORTION settings can be saved/loaded as ten variations. A saved VARIATION can be loaded into a different patch, which is convenient when you're creating sounds.

### TYPE

Value	Explanation
MID BOOST	This is a booster with unique characteristics in the midrange.
CLEAN BOOST	This not only functions as a booster, but also produces a clean tone that has punch even when used alone.
TREBLE BOOST	This is a booster that has bright characteristics.
CRUNCH	A lustrous crunch sound with an added element of amp distortion.
NATURAL OD	This is an overdrive sound that provides distortion with a natural feeling.
WARM OD	This is a warm overdrive.
FAT DS	A distortion sound with thick distortion.
LEAD DS	Produces a distortion sound with both the smoothness of an overdrive along with a deep distortion.
METAL DS	This is a distortion sound that is ideal for performances of heavy riffs.
OCT FUZZ	A fuzz sound with rich harmonic content.
A-DIST	This uses MDP technology to obtain ideal distortion in all ranges of the guitar, from low to high.
X-OD	This is an overdrive that uses MDP to obtain the distortion that's most appropriate in each pitch range.
X-DIST	This is a distortion that uses MDP to obtain the distortion that's most appropriate in each pitch range.

Value	Explanation
BLUES OD	This is a crunch sound of the BOSS BD-2. This produces distortion that faithfully reproduces the nuances of picking.
OD-1	This models the sound of the BOSS OD-1. This produces sweet, mild distortion.
T-SCREAM	This models an Ibanez TS-808.
TURBO OD	This is the high-gain overdrive sound of the BOSS OD-2.
DIST	This gives a basic, traditional distortion sound.
CENTA OD	This models a KLON CENTAUR.
RAT	This models a Proco RAT.
GUV DS	This models a Marshall GUV'NOR.
DIST+	This models the sound of the MXR DISTORTION+.
METAL ZONE	This models the sound of the BOSS MT-2. It produces a wide range of metal sounds, from old style to slash metal.
HM-2	This models the sound of the BOSS HM-2. It produces distinctive cranked-up distortion sound with compression.
METAL CORE	This models the sound of the BOSS ML-2. It produces a sound that is ideal for high-speed metal riffs.
'60S FUZZ	This models a FUZZFACE. It produces a fat fuzz sound.
MUFF FUZZ	This models an Electro-Harmonix Big Muff $\pi$ .
BASS OD	Overdrive tuned especially for use with basses.
BASS DS	Distortion tuned especially for use with basses.
BASS MT	Wild, radical distortion sound.
BASS FUZZ	Fuzz tuned especially for use with basses.
HI BAND DRIVE	With this effect, distortion is applied only to the high frequency sounds, and not to the sounds in the low frequency range. It is distinctive for producing a strong low-end even when intensely distorted.
X-BASS OD	This effect uses MDP to provide ideal distortion in all pitch ranges of the bass, from low to high.
BASS DRV	This models a TECH21 SANSAMP BASS DRIVER DI.
BASS DI	This models a MXR Bass D.I.+.

## EQ 1, EQ2

STEREO

You can adjust the tone character in four bands.

Parameter	Value	Explanation
ON/OFF	OFF, ON	Turns this effect on/off.
LOW CUT	FLAT, 20.0 Hz–16.0 kHz	This sets the frequency at which the low cut filter begins to take effect. When FLAT is selected, the low cut filter will have no effect.
LOW GAIN	-20–+20 dB	Adjusts the tone for the low frequency range.
LOW-MID FREQ	20.0 Hz–16.0 kHz	Specifies the center of the frequency range that will be adjusted by the LOW-MID GAIN.
LOW-MID Q	0.5–16	Adjusts the width of the area affected by the EQ centered at the LOW-MID FREQ. Higher values will narrow the area.
LOW-MID GAIN	-20–+20 dB	Adjusts the low-middle frequency range tone.
HIGH-MID FREQ	20.0 Hz–16.0 kHz	Specifies the center of the frequency range that will be adjusted by the HIGH-MID GAIN.
HIGH-MID Q	0.5–16	Adjusts the width of the area affected by the EQ centered at the HIGH-MID FREQ. Higher values will narrow the area.
HIGH-MID GAIN	-20–+20 dB	Adjusts the high-middle frequency range tone.
HIGH GAIN	-20–+20 dB	Adjusts the tone for the high frequency range.
HIGH CUT	20.0 Hz–16.0 kHz, FLAT	This sets the frequency at which the high cut filter begins to take effect. When FLAT is selected, the high cut filter will have no effect.
LEVEL	-20–+20 dB	Adjusts the overall volume level of the equalizer.
VARIATION	PATCH, 01–10	EQ settings can be saved/loaded as ten variations. A saved VARIATION can be loaded into a different patch, which is convenient when you're creating sounds. These variations are shared with the PARAMETRIC EQ setting in FX1–FX3.

# MASTER DELAY



Adds delayed sound to the direct sound, giving more body to the sound or creating special effects.

Parameter	Value	Explanation
ON/OFF	OFF, ON	Turns this effect on/off.
TYPE	Selects the DELAY type "TYPE" (p. 59). * The stereo effect is canceled if a mono effect or AMP Modeling is connected after a stereo delay effect.	
TIME *1 *12	1 ms–2000 ms, BPM	Adjusts the delay time.
D1 TIME D2 TIME *2 *12		
FEEDBACK *3	0–100	This sets the amount of delay sound returned to the input. A higher value will increase the number of the delay repeats.
D1 FEEDBACK D2 FEEDBACK *2		
EFFECT LEVEL *4	0–120	Adjusts the volume of the delay sound.
D1 EFFECT LEVEL D2 EFFECT LEVEL *2		
HIGH CUT *3	20.0 Hz–16.0 kHz, FLAT	This sets the frequency at which the high cut filter begins to take effect. When FLAT is selected, the high cut filter will have no effect.
D1 HIGH CUT D2 HIGH CUT *2		
TAP TIME *6	0–100%	Adjusts the delay time of the right channel delay. This setting adjusts the R channel delay time relative to the L channel delay time (considered as 100%).
MOD RATE *7	0–100	Adjusts the modulation rate of the delay sound.
MOD DEPTH *7	0–100	Adjusts the modulation depth of the delay sound.
TRIGGER *8	OFF, ON	If this is ON, the WARP effect is applied.
MODE *9	RISE → FALL RISE → FADE	Rotation stops when you switch TRIGGER from ON to OFF. When you switch TRIGGER from ON to OFF, fade-out occurs while continuing the rotation.
TRIGGER *9	OFF, ON	The TWIST effect is applied when you turn this ON.
RISE TIME *9	0–100	This parameter adjusts the amount of time it is to take for the effect to transition to the maximum.
FALL TIME *9 *10	0–100	This parameter adjusts the amount of time it is to take for the effect to transition to the original.
FADE TIME *9 *11	0–100	Adjusts the fade-out time.

Parameter	Value	Explanation
DIRECT LEVEL *5	0–100	Adjusts the volume of the direct sound.
CARRY OVER	OFF, ON	Specifies whether the effect sound remains when you turn off the effect, or does not remain.
BPM	40–250	Adjusts the BPM value for each patch.
VARIATION	PATCH, 01–10	DELAY settings can be saved/loaded as ten variations. A saved VARIATION can be loaded into a different patch, which is convenient when you're creating sounds. These variations are shared with the DELAY setting in FX1–FX3.

\*1 Valid when the TYPE is set to other than DUAL-S, DUAL-P, DUAL L/R, or TWIST.

\*2 Valid when the TYPE is set to DUAL-S, DUAL-P, or DUAL L/R.

\*3 Valid when the TYPE is set to other than DUAL-S, DUAL-P, DUAL L/R, WARP or TWIST.

\*4 Valid when the TYPE is set to other than DUAL-S, DUAL-P, or DUAL L/R.

\*5 Valid when the TYPE is set to other than WARP or TWIST.

\*6 Valid when the TYPE is set to PAN.

\*7 Valid when the TYPE is set to MOD.

\*8 Valid when the TYPE is set to WARP.

\*9 Valid when the TYPE is set to TWIST.





\*10 Valid when the MODE is set to RISE → FALL.

\*11 Valid when the MODE is set to RISE → FADE.

\*12 Refer to "About effects when a note value is selected as a setting" (p. 66).

## TYPE

Value	Explanation
STEREO1 	The direct sound is output from the left channel, and the effect sound is output from the right channel.
STEREO2 	This is a stereo-in/out delay.
PAN 	This delay is specifically for stereo output. This allows you to obtain the tap delay effect that divides the delay time, then deliver them to L and R channels. 
DUAL-S 	This is a delay comprising two different delays connected in series.
DUAL-P 	This is a delay comprising two delays connected in parallel.
DUAL-L/R 	This delay lets you specify the L and R channels independently. Delay 1 goes to the left channel, Delay 2 to the right.
REVERSE 	This produces an effect where the sound is played back in reverse.

Value	Explanation
ANALOG 	This gives a mild analog delay sound.
TAPE 	This setting provides the characteristic wavering sound of the tape echo.
MOD 	A delay with a pleasant amount of modulation added.
WARP 	Produces a dream-like sound.
TWIST 	Produces an aggressive sense of rotation. Using this in conjunction with distortion will produce an even wilder sense of rotation.

## DELAY 1, DELAY 2

STEREO

Adds delayed sound to the direct sound, giving more body to the sound or creating special effects.

Parameter	Value	Explanation
ON/OFF	OFF, ON	Turns this effect on/off.
TIME *1	1 ms–2000 ms, BPM  <small>flat</small>	Adjusts the delay time.
FEEDBACK	0–100	This sets the amount of delay sound returned to the input. A higher value will increase the number of the delay repeats.
EFFECT LEVEL	0–120	Adjusts the volume of the delay sound.
HIGH CUT	20.0 Hz–16.0 kHz, FLAT	This sets the frequency at which the high cut filter begins to take effect. When FLAT is selected, the high cut filter will have no effect.
DIRECT LEVEL	0–100	Adjusts the volume of the direct sound.
CARRY OVER	OFF, ON	Specifies whether the effect sound remains when you turn off the effect, or does not remain.
BPM	40–250	Adjusts the BPM value for each patch.
VARIATION	PATCH, 01–10	DELAY settings can be saved/loaded as ten variations. A saved VARIATION can be loaded into a different patch, which is convenient when you're creating sounds.

\*1 Refer to "About effects when a note value is selected as a setting" (p. 66).

# REVERB



This effect adds reverberation to the sound.

Parameter	Value	Explanation
ON/OFF	OFF, ON	Turns this effect on/off.
TYPE	This selects the reverb type. Various different simulations of space are offered.	
	AMBIENCE	Simulates an ambience mic (off-mic, placed at a distance from the sound source) used in recording and other applications. Rather than emphasizing the reverberation, this reverb is used to produce a sense of openness and depth.
	ROOM	Simulates the reverberation in a small room. Provides warm reverberations.
	HALL1	Simulates the reverberation in a concert hall. Provides clear and spacious reverberations.
	HALL2	Simulates the reverberation in a concert hall. Provides mild reverberations.
	PLATE	Simulates plate reverberation (a reverb unit that uses the vibration of a metallic plate). Provides a metallic sound with a distinct upper range.
	SPRING	This simulates the sound of a guitar amp's built-in spring reverb.
	MOD	This reverb adds the wavering sound found in hall reverb to provide an extremely pleasant reverb sound.
TIME	0.1 s–10.0 s	Adjusts the length (time) of reverberation.
PRE-DELAY	0 ms–500 ms	Adjusts the time until the reverb sound appears.
EFFECT LEVEL	0–100	Adjusts the volume of the reverb sound.
LOW CUT	FLAT, 20.0 Hz–16.0 kHz	This sets the frequency at which the low cut filter begins to take effect. When FLAT is selected, the low cut filter will have no effect.
HIGH CUT	20.0 Hz–16.0 kHz, FLAT	This sets the frequency at which the high cut filter begins to take effect. When FLAT is selected, the high cut filter will have no effect.
DENSITY	1–10	Adjusts the density of the reverb sound.
DIRECT LEVEL	0–100	Adjusts the volume of the direct sound.
CARRY OVER	OFF, ON	Specifies whether the effect sound remains when you turn off the effect, or does not remain.
SPRING SENS *1	0–100	Adjusts the sensitivity of the spring effect. When the value is set higher, the effect is obtained even with a weak picking.

Parameter	Value	Explanation
VARIATION	PATCH, 01–10	REVERB settings can be saved/loaded as ten variations. A saved VARIATION can be loaded into a different patch, which is convenient when you're creating sounds. These variations are shared with the REVERB setting in FX1–FX3.

\*1 Valid when the TYPE is set to SPRING.

## NOISE SUPPRESSOR STEREO

This effect reduces the noise and hum picked up by guitar pickups. Since it suppresses the noise in synchronization with the envelope of the guitar sound (the way in which the guitar sound decays over time), it has very little effect on the guitar sound, and does not harm the natural character of the sound.

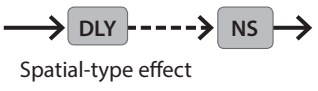
Parameter	Value	Explanation
ON/OFF	OFF, ON	Turns this effect on/off.
THRESHOLD	0-100	Adjust this parameter as appropriate for the volume of the noise. If the noise level is high, a higher setting is appropriate. If the noise level is low, a lower setting is appropriate. Adjust this value until the decay of the guitar sound is as natural as possible.  * High settings for the threshold parameter may result in there being no sound when you play with your guitar volume turned down.
RELEASE	0-100	Adjusts the time from when the noise suppressor begins to function until the noise level reaches "0."
DETECT	This controls the noise suppressor based on the volume level for the point specified in Detect.	
	GK INPUT *1	Input volume from the GK IN jack. * Set the GK SETTING parameter SENS (p. 83) appropriately.
	NORMAL INPUT	Input volume from the GUITAR INPUT jack.
	NS INPUT	Noise suppressor input volume. * When connected as illustrated below, and you want to prevent a spatial-type effects sound (such as a delay sound) from being eradicated by the NS, you should set DETECT to "NS INPUT."  
	INST1 OUT	Specifies the output volume of the INST.
INST2 OUT		
INST3 OUT		
VARIATION	PATCH, 01-10	NOISE SUPPRESSOR settings can be saved/loaded as ten variations. A saved VARIATION can be loaded into a different patch, which is convenient when you're creating sounds.

\*1 Setting available with GK PATCH.

## FOOT VOLUME 1, FOOT VOLUME 2 STEREO

This is a volume control effect.

Normally, this is controlled with the expression pedal connected to the CTL 3, 4/EXP 1 jack or CTL 5, 6/EXP 2 jack.

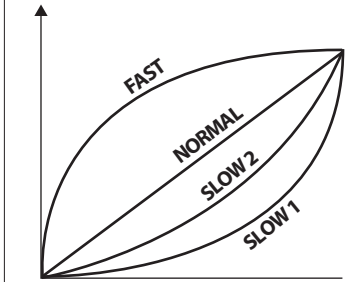
Parameter	Value	Explanation
VOLUME MIN	0-100	Sets the volume when the heel of the EXP Pedal is depressed.
VOLUME MAX	0-100	Selects the volume when the toe of the EXP Pedal is depressed.
VOLUME CURVE	SLOW1, SLOW2, NORMAL, FAST	You can select how the actual volume changes relative to the amount the pedal is pressed. Volume  When the pedal is fully raised      When the pedal is fully advanced
PEDAL POSITION	0-100	Adjusts the volume.
VARIATION	PATCH, 01-10	FOOT VOLUME settings can be saved/loaded as ten variations. A saved VARIATION can be loaded into a different patch, which is convenient when you're creating sounds.  These variations are shared with the FOOT VOLUME setting in FX1-FX3.

## SEND/RETURN

MONO

You can connect an external effects processor between the SEND jack and RETURN jack, and use it as one of the SY-1000's effects processors.

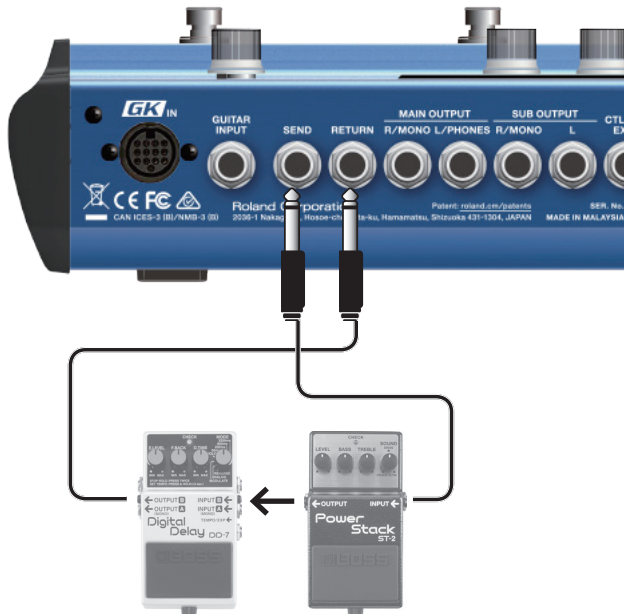

The sound that is input to SEND/RETURN within the effect chain will be output to the SEND jack. The sound that is input via the RETURN jack will be input to SEND/RETURN within the effect chain.

Parameter	Value	Explanation
ON/OFF	OFF, ON	Turns on/off the SEND/RETURN.
MODE		Selects the signal flow "MODE" (p. 63).
SEND LEVEL	0–200	Adjusts the volume of the output to the external effects device.
RETURN LEVEL *1	0–200	Adjusts the volume of the input from the external effects device.
ADJUST *1	0–100	Adjusts the phase between the SY-1000's internal processing and an external effect unit connected to the SEND/RETURN jacks.
PHASE	NORMAL, INVERT	Specifies the phase of the signal that is output from the SEND jack.

\*1 You can adjust this if the MODE parameter is set to NORMAL or DIRECT MIX.

## MODE

Value	Explanation
NORMAL	<p>The input to SEND/RETURN within the effect chain will be output to the SEND jack, and the input from the RETURN jack will be output following SEND/RETURN.</p> <p>Use this setting if you want to connect an external effects processor in series within the SY-1000's effect chain.</p>

Value	Explanation
DIRECT MIX	<p>The input to SEND/RETURN within the effect chain will be output to the SEND jack, and the input from the RETURN jack and the input to SEND/RETURN (the direct sound) will be mixed and output following SEND/RETURN.</p> <p>Use this when you want to mix the SY-1000's effects sounds together with the external effects device applied to it.</p>
BRANCH OUT	<p>The input to SEND/RETURN within the effect chain will be output to the SEND jack. The input from the RETURN jack will be ignored.</p> <p>For example, by placing SEND/RETURN in the SY-1000's effect chain in front of reverb or delay, this allows you to use the SEND jack as a dry out.</p>

## DIVIDER STEREO

This lets you branch channel “A” and channel “B” within the effect chain.

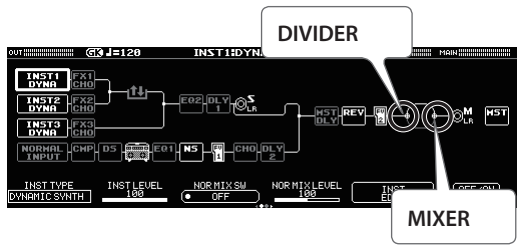

Parameter	Value	Explanation
MODE	SINGLE	Use only one channel, either “A” or “B.”
	DUAL	Use the two channels “A” and “B.”
CH SELECT	A, B	Selects the channel to use. * Setting available when MODE is set to SINGLE.

## MIXER STEREO

This merges the signals that were branched using DIVIDER.

Parameter	Value	Explanation
A/B BALANCE	100:0–0:100	Adjusts the volume balance of channels “A” and “B.” * This is shown only if DIVIDER MODE is set to “DUAL”
A:PAN	L50–R50	Adjusts the pan of channel “A.”
B:PAN	L50–R50	Adjusts the pan of channel “B.”

## BALANCER 1–BALANCER 3

STEREO

This adjusts the volume balance and panning for each of the routes INST1–INST3 and NORMAL INPUT.

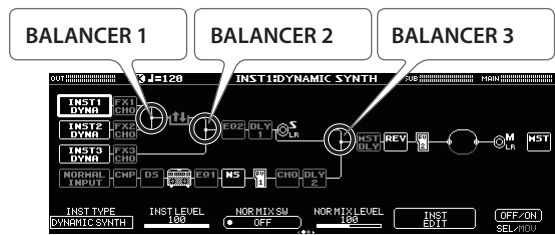

Parameter	Value	Explanation
A/B BALANCE	100:0–0:100	Adjusts the volume balance of channels “A” and “B.”
A:PAN	L50–R50	Adjusts the pan of channel “A.”
B:PAN	L50–R50	Adjusts the pan of channel “B.”

## MAIN OUT/SUB OUT

These are settings for the MAIN OUT and SUB OUT jacks.

Parameter	Value	Explanation
STEREO LINK	OFF, ON	If this is OFF, L and R can be independently positioned in the chain; if this is ON, they are positioned as a set (stereo).
L:PHASE	NORMAL, INVERT	Specify the phase of the output signal.
R:PHASE	NORMAL, INVERT	

## MASTER

These settings are applied to the overall patch.

Parameter	Value	Explanation
PATCH LEVEL	0–200	Adjusts the volume of the patch.
BPM	40–250	Adjusts the BPM value for each patch. * BPM (beats per minute) indicates the number of quarter note beats that occur each minute
KEY	C (Am)–B (G#m)	This sets the key for the FX HARMONIST.
	<p><b>Major</b> C F B<sup>b</sup> E<sup>b</sup> A<sup>b</sup> D<sup>b</sup></p> <p><b>Minor</b> Am Dm Gm Cm Fm Bbm</p> <p><b>Major</b> C G D A E B F#</p> <p><b>Minor</b> Am Em Bm F#m C#m G#m D#m</p>	
TEMPO HOLD	OFF, ON	Specifies whether the tempo (BPM) changes or is maintained when you switch patches.
PATCH TYPE	GK, NORMAL	Specifies whether this patch is for GK or NORMAL.
GK SET	SYSTEM, SET1-SET10	Selects which GK setting to use when playing the GK PATCH. If you select SYSTEM, the GK setting selected by the system parameter GK SET is used.
NORMAL SET	SYSTEM, SET1-SET10	Selects which NORMAL setting to use when playing a NORMAL PATCH. If you select SYSTEM, the NORMAL setting selected by the system parameter NORMAL SET is used.

**MEMO**

For details on the GK settings parameter, refer to “GK SETTING” (p. 81).

### About effects when a note value is selected as a setting

- \* When you specify a note value as the setting for a parameter (such as a RATE parameter in INST or EFFECTS), this specifies the length (time) of one note. Since this time is calculated based on the “BPM” (tempo) of the MASTER block, you can easily design the sound to match the tempo of the song.
- \* If the note length (time) specified for a RATE or DELAY TIME parameter is longer than the allowable range of the setting, a time that is 1/2 or 1/4 of the specified time is assigned.

## NORMAL INPUT

These are the settings for the normal (conventional) guitar signal that is input to the GUITAR INPUT jack.

Parameter	Value	Explanation
ON/OFF	OFF, ON	Turns this effect on/off.
LEVEL	0–200	Adjusts the volume of the normal guitar.
CABLE SIM	OFF, 1m/3ft, 3m/10ft, 5m/16ft, 7m/23ft, 9m/30ft, 12m/40ft	Since the guitar signal that is detected by the divided pickup passes through an active buffer and is connected via a cable approximately 20 cm (7") long, it will have less high-frequency attenuation. For this reason, the high-frequency range will be different than when you perform using a conventional guitar cable. By setting this parameter to the length of the guitar cable that you typically use, you can compensate for the difference in tonal character between the sound of the divided pickup and the normal guitar sound.
		If you connect a conventional guitar to the GUITAR INPUT jack, set this “OFF.”
PHASE	NORMAL, INVERT	Specifies the phase of the normal pickup signal.

# CONTROL ASSIGN Parameters

## CONTROL FUNCTION

You can control the parameters of the SY-1000 by using the SY-1000's switches or externally-connected devices. Here you can make settings to specify which functions are controlled by which controllers.

## FUNCTION

[BANK▼], [BANK▲], [1]–[4] switch, CTL1–CTL6, CUR NUM, MANUAL1–MANUAL4, GK SW1, GK SW2

CONTROL/ASSIGN 2 CONTROL FUNCTION					
FUNCTION	BANK DOWN	BANK UP	CTL 1	CTL 2	CTL 3
MODE	PATCH	PATCH	PATCH	PATCH	PATCH
PREFERENCE	1	2	3	4	5
FUNCTION	1	2	3	4	5
MODE	PATCH	PATCH	PATCH	PATCH	PATCH
PREFERENCE	1	2	3	4	5
SELECT	VALUE	VALUE	VALUE	VALUE	VALUE

Value	Explanation
OFF	No assignment.
BANK DOWN *1	Switches to the previous BANK number. * This cannot be assigned to the [BANK▲] or [1]–[4] switches.
BANK UP *1	Switches to the next BANK number. * This cannot be assigned to the [BANK▼] or [1]–[4] switches.
1 *1	Selects patch number 1. * This can be assigned only to the [1] switch.
2 *1	Selects patch number 2. * This can be assigned only to the [2] switch.
3 *1	Selects patch number 3. * This can be assigned only to the [3] switch.
4 *1	Selects patch number 4. * This can be assigned only to the [4] switch.
PATCH +1 *1	Switches to the next patch number.
PATCH -1 *1	Switches to the previous patch number.
LEVEL +10	Increases the patch volume level by 10 units.
LEVEL +20	Increases the patch volume level by 20 units.
LEVEL -10	Decreases the patch volume level by 10 units.
LEVEL -20	Decreases the patch volume level by 20 units.
BPM TAP	Used for tap input of the MASTER BPM.
DLY1 TAP	Used for tap input of the DELAY 1.
DLY2 TAP	Used for tap input of the DELAY 2.
MST DLY TAP	Used for tap input of the MASTER DELAY.
FX1 DLY TAP	Used for tap input of the FX1 DELAY.
FX2 DLY TAP	Used for tap input of the FX2 DELAY.
FX3 DLY TAP	Used for tap input of the FX3 DELAY.
TUNER	Switches the TUNER on and off.
MANUAL	Switches the MANUAL on and off.
MANUAL/TUNER	Turns MANUAL on/off when briefly pressed; turns TUNER on/off when long-pressed.
TUNER/MANUAL	Turns TUNER on/off when briefly pressed; turns MANUAL on/off when long-pressed.
INST 1	Switches the INST1 on and off.
INST 2	Switches the INST2 on and off.

Value	Explanation
INST 3	Switches the INST3 on and off.
INST ALL	Switches INST1–INST3 all on/off.
INST1 NOR MIX	Switches the INST1 NORMAL MIX SW on and off.
INST2 NOR MIX	Switches the INST2 NORMAL MIX SW on and off.
INST3 NOR MIX	Switches the INST3 NORMAL MIX SW on and off.
NORMAL	Switches the normal pickup signal on/off.
1:ALT TUNE *6	Switches INST1's ALT TUNE on/off.
2:ALT TUNE *6	Switches INST2's ALT TUNE on/off.
3:ALT TUNE *6	Switches INST3's ALT TUNE on/off.
ALL:ALT TUNE *6	Switches ALT TUNE on/off for all INST1–INST3.
1:12STR *6	Switches INST1's 12STR on/off.
2:12STR *6	Switches INST2's 12STR on/off.
3:12STR *6	Switches INST3's 12STR on/off.
ALL:12STR *6	Switches 12STR on/off for all INST1–INST3.
1:STR BEND *6	Switches INST1's STR BEND on/off.
2:STR BEND *6	Switches INST2's STR BEND on/off.
3:STR BEND *6	Switches INST3's STR BEND on/off.
ALL:STR BEND *6	Switches STR BEND on/off for all INST1–INST3.
INST1 LFO1 *2	Switches INST1's LFO1 on/off.
INST1 LFO2 *2	Switches INST1's LFO2 on/off.
INST1 LFO1&2 *2	Switches LFO1 and LFO2 on/off for INST1.
INST2 LFO1 *2	Switches INST2's LFO1 on/off.
INST2 LFO2 *2	Switches INST2's LFO2 on/off.
INST2 LFO1&2 *2	Switches LFO1 and LFO2 on/off for INST2.
INST3 LFO1 *2	Switches INST3's LFO1 on/off.
INST3 LFO2 *2	Switches INST3's LFO2 on/off.
INST3 LFO1&2 *2	Switches LFO1 and LFO2 on/off for INST3.
INST ALL LFO *2	Switches all LFOs on/off for all INST1–INST3.
INST1 SEQ1 *3	Switches INST1's SEQ1 on/off.
INST1 SEQ2 *3	Switches INST1's SEQ2 on/off.
INST1 SEQ1&2 *3	Switches SEQ1 and SEQ2 on/off for INST1.
INST2 SEQ1 *3	Switches INST2's SEQ1 on/off.
INST2 SEQ2 *3	Switches INST2's SEQ2 on/off.
INST2 SEQ1&2 *3	Switches SEQ1 and SEQ2 on/off for INST2.
INST3 SEQ1 *3	Switches INST3's SEQ1 on/off.
INST3 SEQ2 *3	Switches INST3's SEQ2 on/off.
INST3 SEQ1&2 *3	Switches SEQ1 and SEQ2 on/off for INST3.
INST ALL SEQ *3	Switches all SEQs on/off for all INST1–INST3.
1:SEQ1 TRIG *3	Retrigger SEQ1 of INST1.
1:SEQ2 TRIG *3	Retrigger SEQ2 of INST1.
1:SEQ1&2 TRIG *3	Retrigger SEQ1 and SEQ2 for INST1.
2:SEQ1 TRIG *3	Retrigger SEQ1 of INST2.
2:SEQ2 TRIG *3	Retrigger SEQ2 of INST2.
2:SEQ1&2 TRIG *3	Retrigger SEQ1 and SEQ2 for INST2.
3:SEQ1 TRIG *3	Retrigger SEQ1 of INST3.
3:SEQ2 TRIG *3	Retrigger SEQ2 of INST3.
3:SEQ1&2 TRIG *3	Retrigger SEQ1 and SEQ2 for INST3.
ALL:SEQ TRIG *3	Retrigger all SEQs on/off for all INST1–INST3.

Value	Explanation
1:SEQ1 TURBO	*3 Switches INST1 SEQ1's TURBO on/off.
1:SEQ2 TURBO	*3 Switches INST1 SEQ2's TURBO on/off.
1:SEQ1&2 TURBO	*3 Switches SEQ1 and SEQ2 TURBO on/off for INST1.
2:SEQ1 TURBO	*3 Switches INST2 SEQ1's TURBO on/off.
2:SEQ2 TURBO	*3 Switches INST2 SEQ2's TURBO on/off.
2:SEQ1&2 TURBO	*3 Switches SEQ1 and SEQ2 TURBO on/off for INST2.
3:SEQ1 TURBO	*3 Switches INST3 SEQ1's TURBO on/off.
3:SEQ2 TURBO	*3 Switches INST3 SEQ2's TURBO on/off.
3:SEQ1&2 TURBO	*3 Switches SEQ1 and SEQ2 TURBO on/off for INST3.
ALL:SEQ TURBO	*3 Switches all TURBO of SEQs on/off for all INST1–INST3.
INST1 HOLD	*2 Switches INST1's HOLD on/off.
INST2 HOLD	*2 Switches INST2's HOLD on/off.
INST3 HOLD	*2 Switches INST3's HOLD on/off.
INST ALL HOLD	*2 Switches HOLD on/off for all INST1–INST3.
SYNC TRIG	*2 Retrigger the SEQ and LFO whose SYNC is ON for INST1–INST3.
1:PU SEL UP	*4 *6 Switches the PU of INST1.
2:PU SEL UP	*4 *6 Switches the PU of INST2.
3:PU SEL UP	*4 *6 Switches the PU of INST3.
1:PU SEL DOWN	*4 *6 Switches the PU of INST1.
2:PU SEL DOWN	*4 *6 Switches the PU of INST2.
3:PU SEL DOWN	*4 *6 Switches the PU of INST3.
INST1 AMP	*5 *6 Switches INST1's AMP Modeling on/off.
INST2 AMP	*5 *6 Switches INST2's AMP Modeling on/off.
INST3 AMP	*5 *6 Switches INST3's AMP Modeling on/off.
INST1 AMP SOLO	*5 *6 Switches AMP Modeling solo on/off for INST1.
INST2 AMP SOLO	*5 *6 Switches AMP Modeling solo on/off for INST2.
INST3 AMP SOLO	*5 *6 Switches AMP Modeling solo on/off for INST3.
FX1	Switches the FX1 on and off.
FX2	Switches the FX2 on and off.
FX3	Switches the FX3 on and off.
CMP	Switches the COMPRESSOR on and off.
DS	Switches the DISTORTION on and off.
DS SOLO	Switches the DISTORTION SOLO on and off.
AMP	Switches the AMP on and off.
AMP SOLO	Switches the AMP SOLO on and off.
EQ 1	Switches the EQUALIZER 1 on and off.
EQ 2	Switches the EQUALIZER 2 on and off.
NS	Switches the NOISE SUPPRESSOR on and off.
DLY1	Switches the DELAY 1 on and off.
DLY2	Switches the DELAY 2 on and off.

Value	Explanation
MST DLY	Switches the MASTER DELAY on and off.
CHO	Switches the CHORUS on and off.
REV	Switches the REVERB on and off.
S/R	Switches the SEND/RETURN on and off.
FX1 TRIGGER	Switches the FX1 TRIGGER on and off.
FX2 TRIGGER	Switches the FX2 TRIGGER on and off.
FX3 TRIGGER	Switches the FX3 TRIGGER on and off.
MST DLY TRIGGER	Turns the trigger on/off when the MASTER DELAY's TYPE is WARP or TWIST.
DIV CH.SELECT	Switches the DIVIDER channel select.
MIDI START	Controls the Start/Stop of external MIDI devices (such as sequencers).
MMC PLAY	Controls the Play/Stop of external MIDI devices (such as hard disk recorders).

\*1 This cannot be assigned to CUR NUM and MANUAL1–MANUAL4.

\*2 Valid when the INST TYPE is set to DYNAMIC SYNTH or OSC SYNTH.

\*3 Valid when the INST TYPE is set to DYNAMIC SYNTH.

\*4 Valid when the INST TYPE is set to E.GTR, ACOUSTIC (SITAR), or VIO GUITAR.

\*5 Valid when the INST TYPE is set to E.GTR, ACOUSTIC, AC BASS, or E.BASS.

\*6 Setting available with GK PATCH.

**MEMO**

CUR NUM is valid when the CONTROL MODE (p. 81) is set to MEMORY.

**GK VOL, EXP1, EXP 2**

Value	Explanation
OFF	No assignment.
FV1	Assigns FOOT VOLUME1.
FV2	Assigns FOOT VOLUME2.
FV1+TUNER	Assigns FOOT VOLUME1. TUNER is displayed if the pedal is returned all the way.
FV2+TUNER	Assigns FOOT VOLUME2. TUNER is displayed if the pedal is returned all the way.
FX1 PEDAL POS.	*3 Assigns the PEDAL POSITION of FX1.
FX2 PEDAL POS.	*3 Assigns the PEDAL POSITION of FX2.
FX3 PEDAL POS.	*3 Assigns the PEDAL POSITION of FX3.
PATCH LEVEL100	Assigns the function of controlling PATCH LEVEL in the range 0–100.
PATCH LEVEL200	Assigns the function of controlling PATCH LEVEL in the range 0–200.
INST1 LEVEL	Assigns the LEVEL of INST1.
INST2 LEVEL	Assigns the LEVEL of INST2.
INST3 LEVEL	Assigns the LEVEL of INST3.
INST ALL LEVEL	Assigns the LEVEL of all INST1–INST3.
INST1 CUTOFF	*1 Assigns the CUTOFF of INST1.
INST2 CUTOFF	*1 Assigns the CUTOFF of INST2.

Value	Explanation
INST3 CUTOFF	*1 Assigns the CUTOFF of INST3.
INST ALL CUTOFF	*1 Assigns the CUTOFF of all INST1–INST3.
INST1 RESO	*1 Assigns the RESONANCE of INST1.
INST2 RESO	*1 Assigns the RESONANCE of INST2.
INST3 RESO	*1 Assigns the RESONANCE of INST3.
INST ALL RESO	*1 Assigns the RESONANCE of all INST1–INST3.
1:GTR VOL	*2 *4 Assigns the GUITAR (BASS) VOLUME of INST1.
2:GTR VOL	*2 *4 Assigns the GUITAR (BASS) VOLUME of INST2.
3:GTR VOL	*2 *4 Assigns the GUITAR (BASS) VOLUME of INST3.
ALL:GTR VOL	*2 *4 Assigns the GUITAR (BASS) VOLUME of all INST1–INST3.
1:NOR MIX 100	Assigns the function of controlling the NOR MIX LEVEL of INST1 in the range 0–100.
1:NOR MIX 200	Assigns the function of controlling the NOR MIX LEVEL of INST1 in the range 0–200.
2:NOR MIX 100	Assigns the function of controlling the NOR MIX LEVEL of INST2 in the range 0–100.
2:NOR MIX 200	Assigns the function of controlling the NOR MIX LEVEL of INST2 in the range 0–200.
3:NOR MIX 100	Assigns the function of controlling the NOR MIX LEVEL of INST3 in the range 0–100.
3:NOR MIX 200	Assigns the function of controlling the NOR MIX LEVEL of INST3 in the range 0–200.
ALL:NOR MIX 100	Assigns the function of controlling the NOR MIX LEVEL of INST1–INSTS3 in the range 0–100.
ALL:NOR MIX 200	Assigns the function of controlling the NOR MIX LEVEL of INST1–INSTS3 in the range 0–200.
1:STR BEND	*4 Assigns the STR BEND CONTROL of INST1.
2:STR BEND	*4 Assigns the STR BEND CONTROL of INST2.
3:STR BEND	*4 Assigns the STR BEND CONTROL of INST3.
ALL:STR BEND	*4 Assigns the STR BEND CONTROL of all INST1–INST3.
1:DYNA BEND	Assigns PITCH BEND of DYNAMIC SYNTH for INST1.
2:DYNA BEND	Assigns PITCH BEND of DYNAMIC SYNTH for INST2.
3:DYNA BEND	Assigns PITCH BEND of DYNAMIC SYNTH for INST3.
ALL:DYNA BEND	Assigns PITCH BEND of DYNAMIC SYNTH for all INST1–INST3.
MIXER BAL	Assigns the A/B BALANCE of MIXER.
BALANCER 1	Assigns the A/B BALANCE of BALANCER1.
BALANCER 2	Assigns the A/B BALANCE of BALANCER2.
BALANCER 3	Assigns the A/B BALANCE of BALANCER3.

\*1 Valid when the INST TYPE is set to DYNAMIC SYNTH, OSC SYNTH, or GR-300.

\*2 Valid when the INST TYPE is set to E.GUITAR, ACOUSTIC, AC BASS, or E.BASS.

\*3 Valid for the PEDAL POSITION parameters of PEDAL BEND, WAH, and FOOT VOLUME respectively.

\*4 Setting available with GK PATCH.

## MODE

CONTROL ASSIGN/CONTROL FUNCTION					
FUNCTION	BANK ◀	BANK ▶	CTL 1	CTL 2	CTL 3
	DEF	DEF	DEF	DEF	DEF
MODE					
PREFERENCE	PATCH	PATCH			
FUNCTION	NUM 1	NUM 2	NUM 3	NUM 4	NUM 5
PREFERENCE	PATCH	PATCH	PATCH	PATCH	PATCH
MODE SELECT	VALUE	VALUE	VALUE	VALUE	VALUE

Value	Explanation
TOGGLE	The setting is toggled On (maximum value) or Off (minimum value) with each press of the footswitch.
MOMENT	The normal state is Off (minimum value), with the switch On (maximum value) only while the footswitch is depressed.



## PREFERENCE

Value	Explanation
PATCH	Different settings can be made independently for each patch.
SYSTEM	The same settings will be shared by all patches.

# ASSIGN SETTING

## ASSIGN 1–ASSIGN 16

For each parameter, you can specify, in detail, which controller will control which parameter. You can create 16 sets of such assignments.

Parameter	Value	Explanation
SW	OFF, ON	Turns the ASSIGN 1–16 on/off.
TARGET	This selects the parameter to be changed. Refer to “TARGET list” (p. 71).	
MIN	*6	This sets the minimum value for the range in which the parameter can change. The value differs depending on the parameter assigned for TARGET parameter.
MAX	*6	This sets the maximum value for the range in which the parameter can change. The value differs depending on the parameter assigned for TARGET parameter.
SOURCE	*6	This selects the controller that will operate the parameter. Refer to “SOURCE list” (p. 76).
MODE	MOMENT	The normal state is Off (minimum value), with the switch On (maximum value) only while the footswitch is depressed.
	TOGGLE	The setting alternately switches to OFF (minimum value) and ON (maximum value) each time the footswitch is pressed.
ACT LOW	0–126	You can set the controllable range for target parameters within the source’s operational range.
ACT HIGH	1–127	Target parameters are controlled within the range set with ACT LOW and ACT HIGH. You should normally set ACT LOW to 0 and ACT HIGH to 127.
RISE TIME	*5 *6 *7 0–100	Adjusts the time over which the target changes from minimum to maximum.
FALL TIME	*5 *6 *7 0–100	Adjusts the time over which the target changes from maximum to minimum.
INPUT SENS	0–100	Adjusts the input sensitivity when STRING1–STRING6, STR HiC–STR LowB, STRING ALL, or NORMAL INPUT is selected as the SOURCE.
WAVE PEDAL FORM	SAW	
	TRI	
	SINE	

Parameter	Value	Explanation
WAVE PEDAL RATE	*4 0–100, BPM 	Specifies the time for one cycle of the wave pedal.
MIDI CH	*2 *3 SYSTEM	The message is transmitted on the MIDI channel specified by TX CHANNEL of “MIDI SETTING” (p. 89).
	1–16	The message is transmitted on the specified MIDI channel.
MIDI CC#	*2 0–127	The message is transmitted using the specified controller number.
MIDI CC# MIN	*2 0–127	Selects the minimum value of the transmitted CC# message.
MIDI CC# MAX	*2 0–127	Selects the maximum value of the transmitted CC# message.
MIDI PC#	*3 1–128	Specifies the program number that is transmitted.
MIDI PC# BANK MSB	*3 OFF, 1–127	Specifies the bank select MSB that is transmitted. If this is OFF, the bank select MSB is not transmitted.
MIDI PC# BANK LSB	*3 OFF, 1–127	Specifies the bank select LSB that is transmitted. If this is OFF, the bank select LSB is not transmitted.

\*1 Valid when the SOURCE is set to WAVE PEDAL.

\*2 Valid when the TARGET is set to MIDI CC#.

\*3 Valid when the TARGET is set to MIDI PC#.

\*4 Refer to “About effects when a note value is selected as a setting” (p. 66).

\*5 Valid when the SOURCE is set to other than EXP1, EXP2, GK VOL, or WAVE PEDAL.

\*6 Valid when the TARGET is set to other than BPM TAP, DLY1 TAP, DLY2 TAP, MST DLY TAP, FX1 DLY TAP, FX2 DLY TAP, FX3 DLY TAP, PU SELECT UP, PU SELECT DOWN, SEQ RETRIGGER, SYNC RETRIGGER, or MIDI PC#.

\*7 Valid when the SOURCE is set to other than STRING1–STRING6, STR HiC–STR LowB, STRING ALL, NORMAL IN, or MIDI CC#.

## TARGET list

TUNER		INST 1:ALT TUNE INST 2:ALT TUNE INST 3:ALT TUNE		INST 1:ALT TUNE INST 2:ALT TUNE INST 3:ALT TUNE		INST 1:DYNAMIC SYNTH:OSC INST 2:DYNAMIC SYNTH:OSC INST 3:DYNAMIC SYNTH:OSC	
TUNER		TUNING TYPE		12STR FINE HiC *2		FEEDBACK	
<b>MASTER</b>		PITCH 6 *1		12STR LEVEL 6 *1		HARMONICS	
BPM		PITCH 5 *1		12STR LEVEL 5 *1		S-SAW DETUNE	
KEY		PITCH 4 *1		12STR LEVEL 4 *1		P. ENV ATTACK	
PATCH LEVEL		PITCH 3 *1		12STR LEVEL 3 *1		P. ENV DEPTH	
<b>TAP</b>		PITCH 2 *1		12STR LEVEL 2 *1		P. BEND DEPTH	
BPM TAP		PITCH 1 *1		12STR LEVEL 1 *1		P. BEND CTL	
DLY1 TAP		PITCH LowB *2		12STR LEVEL LowB *2		SYNC SW *3	
DLY2 TAP		PITCH 4th *2		12STR LEVEL 4th *2		RING SW *3	
MST DLY TAP		PITCH 3rd *2		12STR LEVEL 3rd *2		<b>INST 1:DYNAMIC SYNTH:FILTER INST 2:DYNAMIC SYNTH:FILTER INST 3:DYNAMIC SYNTH:FILTER</b>	
FX1 DLY TAP		PITCH 2nd *2		12STR LEVEL 2nd *2		ON/OFF	
FX2 DLY TAP		PITCH 1st *2		12STR LEVEL 1st *2		TYPE	
FX3 DLY TAP		PITCH HiC *2		12STR LEVEL HiC *2		SLOPE	
<b>INST 1 INST 2 INST 3</b>		FINE 6 *1		12STR DELAY 6 *1		CUTOFF	
ON/OFF		FINE 5 *1		12STR DELAY 5 *1		RESONANCE	
TYPE		FINE 4 *1		12STR DELAY 4 *1		FLT ENV ATTACK	
LEVEL		FINE 3 *1		12STR DELAY 3 *1		FLT ENV DEPTH	
NORMAL MIX SW		FINE 2 *1		12STR DELAY 2 *1		<b>INST 1:DYNAMIC SYNTH:AMP INST 2:DYNAMIC SYNTH:AMP INST 3:DYNAMIC SYNTH:AMP</b>	
NORMAL MIX LEVEL		FINE 1 *1		12STR DELAY 1 *1		A.ENV ATTACK	
STRING LEVEL 6 *1		FINE LowB *2		12STR DELAY LowB *2		LOW CUT	
STRING LEVEL 5 *1		FINE 4th *2		12STR DELAY 4th *2		HIGH CUT	
STRING LEVEL 4 *1		FINE 3rd *2		12STR DELAY 3rd *2		<b>INST 1:DYNAMIC SYNTH:LFO1 INST 2:DYNAMIC SYNTH:LFO1 INST 3:DYNAMIC SYNTH:LFO1</b>	
STRING LEVEL 3 *1		FINE 2nd *2		12STR DELAY 2nd *2		<b>INST 1:DYNAMIC SYNTH:LFO2 INST 2:DYNAMIC SYNTH:LFO2 INST 3:DYNAMIC SYNTH:LFO2</b>	
STRING LEVEL 2 *1		FINE 1st *2		12STR DELAY 1st *2		ON/OFF	
STR LEVEL LowB *2		FINE HiC *2		12STR DELAY HiC *2		SHAPE	
STR LEVEL 4th *2		12STR SW		STR BEND SW		RATE	
STR LEVEL 3rd *2		12STR TYPE		BEND DEPTH 6 *1		DYNAMIC DEPTH	
STR LEVEL 2nd *2		12STR PITCH 6 *1		BEND DEPTH 5 *1		PITCH DEPTH	
STR LEVEL 1st *2		12STR PITCH 5 *1		BEND DEPTH 4 *1		FILTER DEPTH	
STR LEVEL HiC *2		12STR PITCH 4 *1		BEND DEPTH 3 *1		AMP DEPTH	
STRING PAN 6 *1		12STR PITCH 3 *1		BEND DEPTH 2 *1		PWM DEPTH	
STRING PAN 5 *1		12STR PITCH 2 *1		BEND DEPTH 1 *1		FADE TIME	
STRING PAN 4 *1		12STR PITCH 1 *1		BEND DEPTH LowB *2		<b>INST 1:DYNAMIC SYNTH:SEQ COMMON</b>	
STRING PAN 3 *1		12STR PITCH LowB *2		BEND DEPTH 4th *2		<b>INST 2:DYNAMIC SYNTH:SEQ COMMON</b>	
STRING PAN 2 *1		12STR PITCH 4th *2		BEND DEPTH 3rd *2		<b>INST 3:DYNAMIC SYNTH:SEQ COMMON</b>	
STRING PAN 1 *1		12STR PITCH 3rd *2		BEND DEPTH 2nd *2		PITCH TARGET	
STR PAN LowB *2		12STR PITCH 2nd *2		BEND DEPTH 1st *2		CUTOFF TARGET	
STR PAN 4th *2		12STR PITCH 1st *2		BEND DEPTH HiC *2		LEVEL TARGET	
STR PAN 3rd *2		12STR PITCH HiC *2		BEND CONTROL			
STR PAN 2nd *2		12STR FINE 6 *1		<b>INST 1:DYNAMIC SYNTH:OSC INST 2:DYNAMIC SYNTH:OSC INST 3:DYNAMIC SYNTH:OSC</b>			
STR PAN 1st *2		12STR FINE 5 *1		WAVEFORM			
STR PAN HiC *2		12STR FINE 4 *1		PITCH			
<b>INST 1:ALT TUNE INST 2:ALT TUNE INST 3:ALT TUNE</b>		12STR FINE 3 *1		FINE			
ON/OFF		12STR FINE 2 *1		PULSE WIDTH			
		12STR FINE 1 *1		PWM ENV ATTACK			
		12STR FINE LowB *2		PITCH ENV DEPTH			
		12STR FINE 4th *2		DETUNE			
		12STR FINE 3rd *2		SHARPNESS			
		12STR FINE 2nd *2					
		12STR FINE 1st *2					

<b>INST 1:DYNAMIC SYNTH:SEQ1</b>	<b>INST 1:OSC SYNTH:FILTER</b>	<b>INST 1:GR-300</b>	<b>INST 1:AC BASS</b>
<b>INST 2:DYNAMIC SYNTH:SEQ1</b>	<b>INST 2:OSC SYNTH:FILTER</b>	<b>INST 2:GR-300</b> *1	<b>INST 2:AC BASS</b> *2
<b>INST 3:DYNAMIC SYNTH:SEQ1</b>	<b>INST 3:OSC SYNTH:FILTER</b>	<b>INST 3:GR-300</b>	<b>INST 3:AC BASS</b>
<b>INST 1:DYNAMIC SYNTH:SEQ2</b>	SLOPE	<b>INST 1:ANALOG GR</b>	VOLUME
<b>INST 2:DYNAMIC SYNTH:SEQ2</b>	CUTOFF	<b>INST 2:ANALOG GR</b> *2	BODY
<b>INST 3:DYNAMIC SYNTH:SEQ2</b>	CUTOFF FELLOW	<b>INST 3:ANALOG GR</b>	RESONANCE
ON/OFF	RESONANCE	FINE A	SIZE
SYNC	VELOCITY SENS	PITCH B	ATTACK
LOOP LENGTH	F.ENV ATTACK	FINE B	BOTTOM
RATE	F.ENV DECAY	DUET SW	BUZZ SENS
1 SHOT	F.ENV SUSTAIN	SWEEP SW	DECAY
TURBO	F.ENV RELEASE	SWEEP RISE	
	F.ENV DEPTH	SWEEP FALL	<b>INST 1:E.BASS</b>
<b>INST 1:DYNAMIC SYNTH:LAYER</b>		VIBRATO SW	<b>INST 2:E.BASS</b>
<b>INST 2:DYNAMIC SYNTH:LAYER</b>	<b>INST 1:OSC SYNTH:AMP</b>	VIBRATO RATE	<b>INST 3:E.BASS</b>
<b>INST 3:DYNAMIC SYNTH:LAYER</b>	<b>INST 2:OSC SYNTH:AMP</b>	VIBRATO DEPTH	TYPE
L.FADE	<b>INST 3:OSC SYNTH:AMP</b>	LOW CUT	REAR VOLUME
LOWER	VELOCITY SENS	HIGH CUT	FRONT VOLUME
UPPER	A.ENV ATTACK		TOPE TYPE
U.FADE	A.ENV DECAY	<b>INST 1:E.GTR</b>	SENS
	A.ENV SUSTAIN	<b>INST 2:E.GTR</b>	DEPTH
<b>INST 1:OSC SYNTH:OSC</b>	A.ENV RELEASE	<b>INST 3:E.GTR</b>	ATTACK
<b>INST 2:OSC SYNTH:OSC</b>	LOW CUT	TYPE	RESONANCE
<b>INST 3:OSC SYNTH:OSC</b>	HIGH CUT	PU SELECT	DIRECT LEVEL
MODE		PU SELECT UP	VOLUME
WAVEFORM1	<b>INST 1:OSC SYNTH:LFO1</b>	PU SELECT DOWN	TOPE
PITCH 1	<b>INST 2:OSC SYNTH:LFO1</b>	TONE TYPE	MASTER VOLUME
FINE 1	<b>INST 3:OSC SYNTH:LFO1</b>	SENS	REAR TONE
PULSE WIDTH 1	<b>INST 1:OSC SYNTH:LFO2</b>	DEPTH	FRONT TONE
PW MOD RATE 1	<b>INST 2:OSC SYNTH:LFO2</b>	ATTACK	TREBLE
P.ENV ATTACK 1	<b>INST 3:OSC SYNTH:LFO2</b>	RESONANCE	BASS
P.ENV DECAY 1	ON/OFF	DIRECT LEVEL	PU SELECT
P.ENV DEPTH 1	SHAPE	VOLUME	PU SELECT UP
LEVEL 1	RATE	TONE	PU SELECT DOWN
WAVEFORM 2	PITCH1 DEPTH	<b>INST 1:ACOUSTIC</b>	TREBLE ON
PITCH 2	PITCH2 DEPTH	<b>INST 2:ACOUSTIC</b> *1	BASS ON
FINE 2	FILTER DEPTH	<b>INST 3:ACOUSTIC</b>	RHYTHM/SOLO
PULSE WIDTH 2	AMP DEPTH	TYPE	
PW MOD RATE 2	DELAY TIME	BODY	<b>INST 1:VIO GUITAR:GUITAR</b>
P.ENV ATTACK 2	FADE TIME	ATTACK	<b>INST 2:VIO GUITAR:GUITAR</b> *1
P.ENV DECAY 2		PU SELECT	<b>INST 3:VIO GUITAR:GUITAR</b>
P.ENV DEPTH 2	<b>INST 1:GR-300</b>	PU SELECT UP	TYPE
LEVEL 2	<b>INST 2:GR-300</b> *1	PU SELECT DOWN	PU SELECT
MONO/POLY SW	<b>INST 3:GR-300</b>	SENS	PU SELECT UP
CHROMATIC	<b>INST 1:ANALOG GR</b>	COLOR	PU SELECT DOWN
PORTA SW	<b>INST 2:ANALOG GR</b> *2	DECAY	TONE TYPE
PORTA TIME	<b>INST 3:ANALOG GR</b>	BUZZ	SENS
PORTA MODE	MODE	RESONANCE	DEPTH
HOLD MODE	COMP SW	SUSTAIN	ATTACK
LOW VELO CUT	CUTOFF	VOLUME	RESONANCE
	RESONANCE	TONE	DIRECT LEVEL
<b>INST 1:OSC SYNTH:FILTER</b>	ENV MOD SW		VOLUME
<b>INST 2:OSC SYNTH:FILTER</b>	ENV MOD SENS		TOPE
<b>INST 3:OSC SYNTH:FILTER</b>	ENV MOD ATTACK		
ON/OFF	PITCH SW		
TYPE	PITCH A		

**INST 1:VIO GUITAR:HARMO**  
**INST 2:VIO GUITAR:HARMO \*1**  
**INST 3:VIO GUITAR:HARMO**

 PITCH  
 GAIN  
 ATTACK  
 DIRECT LEVEL

**INST 1:VIO GUITAR:FILTER**  
**INST 2:VIO GUITAR:FILTER \*1**  
**INST 3:VIO GUITAR:FILTER**

 OVERTONE  
 ATTACK  
 POWER BEND  
 SLIDE TIME  
 OCTAVE  
 COLOR  
 TOUCH SENS  
 LEAD EMPHASIS

**INST 1:POLY FX**  
**INST 2:POLY FX**  
**INST 3:POLY FX**

 TYPE  
 GUITAR VOLUME \*1  
 BASS VOLUME \*2  
 GAIN  
 GAIN BALANCE  
 COLOR  
 TONE  
 FILTER MODE  
 POLARITY  
 SENS  
 FREQUENCY  
 DECAY  
 PEAK  
 TONE TYPE  
 COMP SW  
 COMP SUSTAIN  
 COMP ATTACK

**INST 1:AMP**  
**INST 2:AMP**  
**INST 3:AMP**

 ON/OFF  
 TYPE  
 GAIN  
 SAG  
 RESONANCE  
 LEVEL  
 BASS  
 MIDDLE  
 TREBLE  
 PRESENCE  
 BRIGHT  
 GAIN SW

**INST 1:AMP**  
**INST 2:AMP**  
**INST 3:AMP**

 SOLO SW  
 SOLO LEVEL  
 SP TYPE  
 MIC TYPE  
 MIC DISTANCE  
 MIC POSITION  
 MIC LEVEL  
 DIRECT LEVEL

**INST 1:NS**  
**INST 2:NS**  
**INST 3:NS**

 ON/OFF  
 THRESHOLD  
 RELEASE

**INST 1:EQ**  
**INST 2:EQ**  
**INST 3:EQ**

 ON/OFF  
 LOW CUT  
 LOW GAIN  
 LOW-MID FREQ  
 LOW-MID Q  
 LOW-MID GAIN  
 HIGH-MID FREQ  
 HIGH-MID Q  
 HIGH-MID GAIN  
 HIGH GAIN  
 HIGH CUT  
 LEVEL

**INST:CONTROL**

 INST1 HOLD  
 INST2 HOLD  
 INST3 HOLD  
 INST ALL HOLD  
 INST1 SEQ1 RETRIGGER  
 INST1 SEQ2 RETRIGGER  
 INST1 SEQ1&2 RETRIGGER  
 INST2 SEQ1 RETRIGGER  
 INST2 SEQ2 RETRIGGER  
 INST2 SEQ1&2 RETRIGGER  
 INST3 SEQ1 RETRIGGER  
 INST3 SEQ2 RETRIGGER  
 INST3 SEQ1&2 RETRIGGER  
 INST ALL SEQ RETRIGGER  
 SYNC RETRIGGER

**NORMAL**

 ON/OFF  
 LEVEL  
 CABLE SIM

**NORMAL**  
 PHASE SW

**FX1**  
**FX2**  
**FX3**

 ON/OFF  
 TYPE

**FX1:AC RESONANCE**  
**FX2:AC RESONANCE**  
**FX3:AC RESONANCE**

 TYPE  
 RESONANCE  
 TONE  
 LEVEL

**FX3:AUTO WAH**  
**FX3:AUTO WAH**  
**FX3:AUTO WAH**

 FILTER MODE  
 RATE  
 DEPTH  
 EFFECT LEVEL  
 FREQUENCY  
 RESONANCE  
 WAVEFORM  
 DIRECT LEVEL

**FX1:CHORUS**  
**FX2:CHORUS**  
**FX3:CHORUS**

 MODE  
 RATE  
 DEPTH  
 PRE-DELAY  
 EFFECT LEVEL  
 WAVEFORM  
 LOW CUT  
 HIGH CUT  
 DIRECT LEVEL  
 RATE1  
 DEPTH1  
 PRE-DELAY1  
 EFFECT LEVEL1  
 WAVEFORM1  
 LOW CUT1  
 HIGH CUT1  
 RATE2  
 DEPTH2  
 PRE-DELAY2  
 EFFECT LEVEL2  
 WAVEFORM2  
 LOW CUT2  
 HIGH CUT2  
 OUTPUT MODE

**FX1:CLASSIC-VIBE**  
**FX2:CLASSIC-VIBE**  
**FX3:CLASSIC-VIBE**

 RATE  
 DEPTH  
 EFFECT LEVEL

**FX1:COMPRESSOR**  
**FX2:COMPRESSOR**  
**FX3:COMPRESSOR**

 TYPE  
 SUSTAIN  
 ATTACK  
 EFFECT LEVEL  
 DIRECT LEVEL  
 TONE

**FX1:DEFRETTOR**  
**FX2:DEFRETTOR**  
**FX3:DEFRETTOR**

 SENS  
 DEPTH  
 TONE  
 EFFECT LEVEL  
 ATTACK  
 RESONANCE  
 DIRECT LEVEL

**FX1:DEFRETTOR BASS**  
**FX2:DEFRETTOR BASS**  
**FX3:DEFRETTOR BASS**

 SENS  
 TONE  
 EFFECT LEVEL  
 ATTACK  
 DIRECT LEVEL

**FX1:DELAY**  
**FX2:DELAY**  
**FX3:DELAY**

 TYPE  
 TIME  
 FEEDBACK  
 EFFECT LEVEL  
 HIGH CUT  
 DIRECT LEVEL  
 TAP TIME  
 TRIGGER  
 CARRY OVER

**FX1:DELAY:DUAL**  
**FX2:DELAY:DUAL**  
**FX3:DELAY:DUAL**

 D1 TIME  
 D1 FEEDBACK  
 D1 HIGH CUT  
 D1 EFFECT LEVEL

<b>FX1:DELAY:DUAL</b>	<b>FX1:GRAPHIC EQ</b>	<b>FX1:LO-FI</b>	<b>FX1:PHASER</b>
<b>FX2:DELAY:DUAL</b>	<b>FX2:GRAPHIC EQ</b>	<b>FX2:LO-FI</b>	<b>FX2:PHASER</b>
<b>FX3:DELAY:DUAL</b>	<b>FX3:GRAPHIC EQ</b>	<b>FX3:LO-FI</b>	<b>FX3:PHASER</b>
D2 TIME	100 Hz	BIT DEPTH	RATE
D2 FEEDBACK	200 Hz	SAMPLE RATE	DEPTH
D2 HIGH CUT	400 Hz	BALANCE	RESONANCE
D2 EFFECT LEVEL	800 Hz		MANUAL
	1.6 kHz	<b>FX1:OCTAVE</b>	STEP RATE
<b>FX1:DELAY: MOD</b>	3.2 kHz	<b>FX2:OCTAVE</b>	EFFECT LEVEL
<b>FX2:DELAY: MOD</b>	6.4 kHz	<b>FX3:OCTAVE</b>	DIRECT LEVEL
<b>FX3:DELAY: MOD</b>	LEVEL	-2OCT	
MOD RATE		-1OCT	<b>FX1:PITCH SHIFTER</b>
MOD DEPTH	<b>FX1:HARMONIST</b>	DIRECT LEVEL	<b>FX2:PITCH SHIFTER</b>
	<b>FX2:HARMONIST</b>		<b>FX3:PITCH SHIFTER</b>
<b>FX1:DELAY:TWIST</b>	<b>FX3:HARMONIST</b>	<b>FX1:OCTAVE BASS</b>	VOICE
<b>FX2:DELAY:TWIST</b>	VOICE	<b>FX2:OCTAVE BASS</b>	PS1:PITCH
<b>FX3:DELAY:TWIST</b>	HR1:HARMONY	<b>FX3:OCTAVE BASS</b>	PS2:PITCH
MODE	HR2:HARMONY	-2OCT	DIRECT LEVEL
RISE TIME	HR1:LEVEL	-1OCT	PS1:MODE
FALL TIME	HR1:PRE-DELAY	DIRECT LEVEL	PS1:FINE
FADE TIME	HR1:FEEDBACK	<b>FX1:PAN</b>	PS1:PRE-DELAY
	DIRECT LEVEL	<b>FX2:PAN</b>	PS1:LEVEL
<b>FX1:FLANGER</b>	HR2:LEVEL	<b>FX3:PAN</b>	PS1:FEEDBACK
<b>FX2:FLANGER</b>	HR2:PRE-DELAY	TYPE	PS2:MODE
<b>FX3:FLANGER</b>		WAVE SHAPE	PS2:FINE
RATE	<b>FX1:HUMANIZER</b>	RATE	PS2:PRE-DELAY
DEPTH	<b>FX2:HUMANIZER</b>	DEPTH	PS2:LEVEL
RESONANCE	<b>FX3:HUMANIZER</b>	EFFECT LEVEL	
MANUAL	MODE	POSITION	<b>FX1:REVERB</b>
SEPARATION	VOWEL1		<b>FX2:REVERB</b>
LOW CUT	VOWEL2	<b>FX1:PARAMETRIC EQ</b>	<b>FX3:REVERB</b>
HIGH CUT	SENS	<b>FX2:PARAMETRIC EQ</b>	TYPE
EFFECT LEVEL	RATE	<b>FX3:PARAMETRIC EQ</b>	TIME
DIRECT LEVEL	DEPTH	LOW CUT	PRE-DELAY
	MANUAL	LOW GAIN	EFFECT LEVEL
<b>FX1:FLANGER BASS</b>	EFFECT LEVEL	LOW-MID FREQ	LOW CUT
<b>FX2:FLANGER BASS</b>		LOW-MID Q	HIGH CUT
<b>FX3:FLANGER BASS</b>	<b>FX1:ISOLATOR</b>	LOW-MID GAIN	DENSITY
RATE	<b>FX2:ISOLATOR</b>	HIGH-MID FREQ	DIRECT LEVEL
DEPTH	<b>FX3:ISOLATOR</b>	HIGH-MID Q	CARRY OVER
RESONANCE	BAND	HIGH-MID GAIN	SPRING SENS
MANUAL	RATE	HIGH GAIN	
SEPARATION	DEPTH	HIGH CUT	<b>FX1:RING MOD</b>
LOW CUT	BAND LEVEL	LEVEL	<b>FX2:RING MOD</b>
HIGH CUT		<b>FX1:PEDAL BEND</b>	<b>FX3:RING MOD</b>
EFFECT LEVEL	<b>FX1:LIMITER</b>	<b>FX2:PEDAL BEND</b>	INTELLIGENT
DIRECT LEVEL	<b>FX2:LIMITER</b>	<b>FX3:PEDAL BEND</b>	FREQUENCY
	<b>FX3:LIMITER</b>	PITCH	FREQ MOD RATE
<b>FX1:FOOT VOLUME</b>	TYPE	PEDAL POSITION	FREQ MOD DEPTH
<b>FX2:FOOT VOLUME</b>	THRESHOLD	EFFECT LEVEL	EFFECT LEVEL
<b>FX3:FOOT VOLUME</b>	RATIO	DIRECT LEVEL	DIRECT LEVEL
VOLUME MIN	EFFECT LEVEL		
VOLUME MAX	ATTACK	<b>FX1:PHASER</b>	<b>FX1:ROTARY</b>
VOLUME CURVE	RELEASE	<b>FX2:PHASER</b>	<b>FX2:ROTARY</b>
PEDAL POSITION		<b>FX3:PHASER</b>	<b>FX3:ROTARY</b>
		TYPE	SPEED SELECT

**FX1:ROTARY**  
**FX2:ROTARY**  
**FX3:ROTARY**

RATE SLOW  
 RATE FAST  
 DEPTH  
 RISE TIME  
 FALL TIME  
 EFFECT LEVEL  
 DIRECT LEVEL

**FX1:SITAR SIM**  
**FX2:SITAR SIM**  
**FX3:SITAR SIM**

SENS  
 DEPTH  
 TONE  
 EFFECT LEVEL  
 RESONANCE  
 BUZZ  
 DIRECT LEVEL

**FX1:SLICER**  
**FX2:SLICER**  
**FX3:SLICER**

PATTERN  
 RATE  
 TRIGGER  
 EFFECT LEVEL  
 ATTACK  
 DUTY  
 DIRECT LEVEL

**FX1:SLOW GEAR**  
**FX2:SLOW GEAR**  
**FX3:SLOW GEAR**

SENS  
 RISE TIME  
 EFFECT LEVEL

**FX1:SLOW GEAR BASS**  
**FX2:SLOW GEAR BASS**  
**FX3:SLOW GEAR BASS**

SENS  
 RISE TIME  
 EFFECT LEVEL

**FX1:SOUND HOLD**  
**FX2:SOUND HOLD**  
**FX3:SOUND HOLD**

TRIGGER  
 RISE TIME  
 EFFECT LEVEL

**FX1:TOUCH WAH**  
**FX2:TOUCH WAH**  
**FX3:TOUCH WAH**

FILTER MODE

**FX1:TOUCH WAH**  
**FX2:TOUCH WAH**  
**FX3:TOUCH WAH**

POLARITY  
 SENS  
 FREQUENCY  
 RESONANCE  
 DECAY  
 EFFECT LEVEL  
 DIRECT LEVEL

**FX1:TOUCH WAH BASS**  
**FX2:TOUCH WAH BASS**  
**FX3:TOUCH WAH BASS**

FILTER MODE  
 POLARITY  
 SENS  
 FREQUENCY  
 RESONANCE  
 DECAY  
 EFFECT LEVEL  
 DIRECT LEVEL

**FX1:TREMOLO**  
**FX2:TREMOLO**  
**FX3:TREMOLO**

WAVE SHAPE  
 RATE  
 DEPTH  
 EFFECT LEVEL  
 DIRECT LEVEL

**FX1:VIBRATO**  
**FX2:VIBRATO**  
**FX3:VIBRATO**

RATE  
 DEPTH  
 TRIGGER  
 RISE TIME  
 EFFECT LEVEL  
 DIRECT LEVEL

**FX1:WAH**  
**FX2:WAH**  
**FX3:WAH**

TYPE  
 PEDAL POSITION  
 PEDAL MIN  
 PEDAL MAX  
 EFFECT LEVEL  
 DIRECT LEVEL

**AMP**

ON/OFF  
 TYPE  
 GAIN  
 SAG

**AMP**

RESONANCE  
 LEVEL  
 BASS  
 MIDDLE  
 TREBLE  
 PRESENCE  
 BRIGHT  
 GAIN SW  
 SOLO SW  
 SOLO LEVEL  
 SP TYPE  
 MIC TYPE  
 MIC DISTANCE  
 MIC POSITION  
 MIC LEVEL  
 DIRECT LEVEL

**DISTORTION**

ON/OFF  
 TYPE  
 DRIVE  
 TONE  
 LEVEL  
 BOTTOM  
 DIRECT LEVEL  
 SOLO SW  
 SOLO LEVEL

**EQ1**  
**EQ2**

ON/OFF  
 LOW CUT  
 LOW GAIN  
 LOW-MID FREQ  
 LOW-MID Q  
 LOW-MID GAIN  
 HIGH-MID FREQ  
 HIGH-MID Q  
 HIGH-MID GAIN  
 HIGH GAIN  
 HIGH CUT  
 LEVEL

**MASTER DELAY**

ON/OFF  
 TYPE  
 TIME  
 FEEDBACK  
 EFFECT LEVEL  
 HIGH CUT  
 DIRECT LEVEL  
 TAP TIME  
 TRIGGER  
 CARRY OVER

**MASTER DELAY:DUAL**

D1 TIME  
 D1 FEEDBACK  
 D1 HIGH CUT  
 D1 EFFECT LEVEL  
 D2 TIME  
 D2 FEEDBACK  
 D2 HIGH CUT  
 D2 EFFECT LEVEL

**MASTER DELAY: MOD**

MOD RATE  
 MOD DEPTH

**MASTER DELAY:TWIST**

MODE  
 RISE TIME  
 FALL TIME  
 FADE TIME

**DELAY1**  
**DELAY2**

ON/OFF  
 TIME  
 FEEDBACK  
 EFFECT LEVEL  
 HIGH CUT  
 DIRECT LEVEL  
 CARRY OVER

**REVERB**

ON/OFF  
 TYPE  
 TIME  
 PRE-DELAY  
 EFFECT LEVEL  
 LOW CUT  
 HIGH CUT  
 DENSITY  
 DIRECT LEVEL  
 CARRY OVER  
 SPRING SENS

**NOISE SUPPRESSOR**

ON/OFF  
 THRESHOLD  
 RELEASE  
 DIRECT

**FOOT VOLUME1**  
**FOOT VOLUME2**

VOLUME MIN  
 VOLUME MAX  
 VOLUME CURVE  
 PEDAL POSITION

**CHORUS**

ON/OFF
MODE
RATE
DEPTH
PRE-DELAY
EFFECT LEVEL
WAVEFORM
LOW CUT
HIGH CUT
DIRECT LEVEL
RATE1
DEPTH1
PRE-DELAY1
EFFECT LEVEL1
WAVEFORM1
LOW CUT1
HIGH CUT1
RATE2
DEPTH2
PRE-DELAY2
EFFECT LEVEL2
WAVEFORM2
LOW CUT2
HIGH CUT2
OUTPUT MODE

**COMPRESSOR**

ON/OFF
TYPE
SUSTAIN
ATTACK
EFFECT LEVEL
DIRECT LEVEL
TOPE

**SEND/RETURN**

ON/OFF
MODE
SEND LEVEL
RETURN LEVEL
ADJUST
PHASE

**DIVIDER**

MODE
CH SELECT

**MIXER**

<b>BALANCER 1</b>
<b>BALANCER 2</b>
<b>BALANCER 3</b>
A/B BALANCE
A:PAN
B:PAN

**MAIN OUT**

MAIN OUT PHASE
MAIN OUT R PHASE

**SUB OUT**

SUB OUT PHASE
SUB OUT R PHASE

**MIDI**

MIDI CC#
MIDI PC#

\*1 Setting available with GUITAR MODE.

\*2 Setting available with BASS MODE.

\*3 Setting available with INST2 and INST3.

**SOURCE list**

Value	Explanation
NUM1–NUM4	Assigns the SY-1000's number [1]–[4] switch.
CUR NUM *3	Assigns the same number switch as the selected patch number.
BANK DOWN	Assigns the SY-1000's [BANK▼] switch.
BANK UP	Assigns SY-1000's [BANK▲] switch.
CTL1, CTL2	Assigns the SY-1000's [CTL1] or [CTL2] switch.
CTL3, CTL4	Assigns the external footswitch connected to the CTL3, 4/EXP1 jack.
CTL5, CTL6	Assigns the external footswitch connected to the CTL5, 6/EXP2 jack.
EXP1	Assigns the external expression pedal connected to the CTL3, 4/EXP1 jack.
EXP2	Assigns the external expression pedal connected to the CTL5, 6/EXP2 jack.
GK SW1, GK SW2	Assign the [S1] and [S2] switches of the divided pickup.
GK VOL	Assigns the volume knob of the divided pickup.
WAVE PEDAL	Assigns the wave pedal. Refer to "Virtual Expression Pedal System (Wave Pedal)" (p. 77).
STRING1–STRING6, STRING ALL *1	The assigned target parameter will change according to the input level.
STR HiC–STR LowB, STRING ALL *2	
NORMAL IN	
CC#1–CC#31, CC#64–CC#95	Assigns the Control Change messages from an external MIDI device.

\*1 Setting available with GUITAR MODE.

\*2 Setting available with BASS MODE.

\*3 Setting available when CONTROL MODE (p. 81) is MEMORY.

## Virtual Expression Pedal System (Wave Pedal)

By assigning a desired parameter to the virtual expression pedal, you can produce an effect as though you were operating a physical expression pedal to change the volume or tone quality in real time.

The virtual expression pedal system can be specified as a SOURCE for ASSIGN 1–ASSIGN 16.

### Wave pedal

If SOURCE is set to “WAVE PEDAL,” the virtual expression pedal will cyclically modify the parameter specified by TARGET in a fixed wave form.



Always changes in a fixed curve regardless of the actual pedal

## STRING1–STRING6, STR HiC–STR LowB, STRING ALL, NORMAL IN

The parameter set as the target changes in response to the input level.

### MEMO

If you want to adjust the input sensitivity, set the INPUT SENS.

## INPUT SENS (Input Sens)

Parameter	Value	Explanation
INPUT SENS	0–100	Adjusts the input sensitivity when STRING1–STRING6, STR HiC–STR LowB, STRING ALL, or NORMAL INPUT is selected as the SOURCE.

### About the Range of a Target’s Change

The target’s value changes between MIN (the minimum value) and MAX (the maximum value).

When using an external footswitch, or other controller that acts as an on/off switch, “Min” is selected with Off (CLOSED), and “Max” is selected with On (OPEN).

When using an external expression pedal or other controller that generates a consecutive change in the value, the value of the setting changes accordingly, within the range set by the minimum and maximum values. Also, when the target is of an on/off type, the median value of the received data is used as the dividing line in determining whether to switch it on or off.

When using the footswitch:

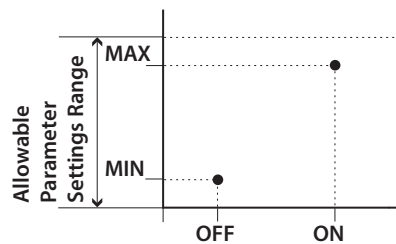

When using the expression pedal:

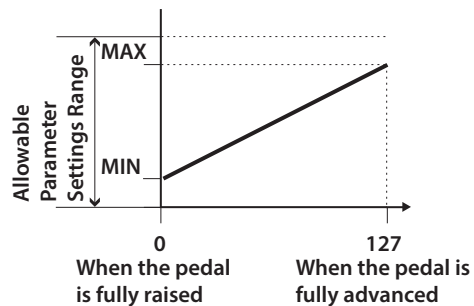

When controlling the On/Off target with the expression pedal:

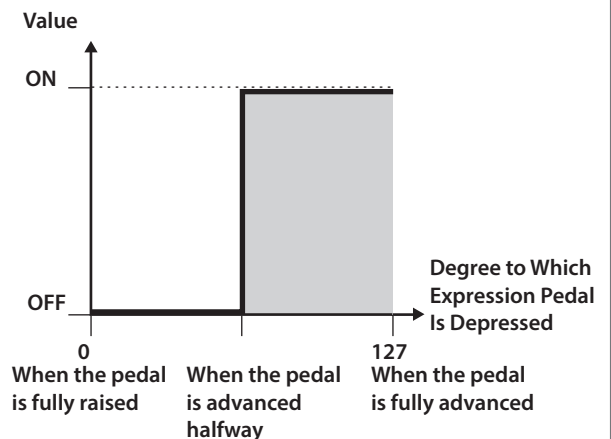

- \* The range that can be selected changes according to the target setting.
- \* When the “minimum” is set to a higher value than the “maximum,” the change in the parameter is reversed.
- \* The values of settings can change if the target is changed after the “minimum” and “maximum” settings have been made. If you’ve changed the target, be sure to recheck the “minimum” and “maximum” settings.

### About the Range of a Controller's Change

This sets the operational range within which the value of the setting changes when an expression pedal or other controller that changes the value consecutively is used as the source. If the controller is moved outside the operational range, the value does not change, it stops at "minimum" or "maximum."

(Example) With ACT LOW: 40, ACT HIGH: 80

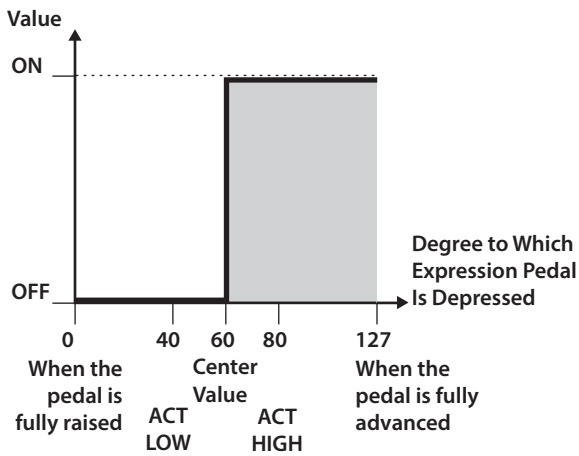
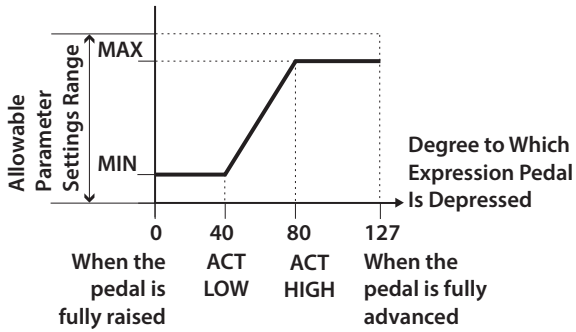

\* When using a footswitch or other on/off switching controller as the source, leave these at "ACT LOW: 0" and "ACT HIGH: 127." With certain settings, the value may not change.

## PATCH MIDI

When you change patches, a program number and bank select messages are transmitted to an external MIDI device.

\* If the "MIDI SETTING" parameter "TX PC MAP" is set to FIX, the PATCH MIDI function will not operate. Set the parameter to "PATCH MIDI."

### PATCH MIDI 1–PATCH MIDI 4

Parameter	Value	Explanation
CHANNEL (CH)	OFF, 1–16	Specifies the transmit channel for MIDI messages. If this is OFF, no MIDI message is transmitted.
PC#	OFF, 1–128	Specifies whether a program number is transmitted when you switch patches. If this is OFF, no program number is transmitted.
BANK MSB BANK LSB	OFF, 1–127	Specifies whether bank select messages are transmitted when you switch patches. * It is not possible to transmit only BANK LSB. * Not transmitted if PC# is OFF. * It is not possible to transmit only bank select. Bank select is always transmitted in conjunction with program numbers.
CC1# CC2#	OFF, 1–127	Specifies whether a control change is transmitted when you switch patches. If this is OFF, no control change is transmitted.
CC1 VALUE CC2 VALUE	0–127	Specifies the value of the control change.

## GUITAR TO MIDI/BASS TO MIDI

These parameters are set for each individual patch with the GUITAR TO MIDI/BASS TO MIDI function.

For details on GUITAR TO MIDI/BASS TO MIDI function parameters that affect the entire SY-1000, refer to SYSTEM parameters.

Parameter	Value	Explanation
MODE		This sets the transmission mode for the MIDI messages.
	MONO	In this mode, one channel per string is used, thus using a total of six channels. Since each string uses a different MIDI channel, you can select a different tone for each string, using string bending or continuously varying the pitch on a specific string; however, this requires use of a multitimbral sound module.
	POLY	In this mode, the messages for all six strings are transmitted over a single channel. While transmitting the MIDI messages for all of the strings over one channel does simplify the settings needed for the sound module, it does impose certain limitations; for example, permitting only one tone to be selected for all of the strings.
ALT TUNE	OFF, INST1, INST2, INST3	Specifies which ALT TUNE data of INST1–INST3 is applied to GUITAR TO MIDI/BASS TO MIDI.
CHROMATIC		When you use CHROMATIC, the pitch changes of the MIDI messages that are transmitted when you gradually change the pitch of your guitar or bass (e.g., by bending a string) will be in semitone steps.
	OFF	Normal Pitch Bend messages are output. The pitch varies continuously in keeping with the string bending or vibrato.
	TYPE1	When the pitch changes, this setting applies the results of the pitch change information without stopping the note that is playing. This produces a unique effect, whereby there is no attack sound when the pitches change, similar to slurring on a recorder.
	TYPE2	When the pitch changes, the SY-1000 retriggers the sound at the changed pitch, producing pitch changes only at the semitone increments. As a result, the attack sound plays each time the pitch changes. The attenuation of the string vibration following the moment the string is played is reflected in the gradual fading of the retriggered sound.
	TYPE3	As with CHROMATIC TYPE 2, sounds are retriggered at the changed pitch, expressing the pitch changes only in semitones. However, the difference is that even if the string vibration is decreasing, the retriggered note will be the same strength as when you first played the string.

Parameter	Value	Explanation
DYNAMICS	1–10	Adjusts the sensitivity of the tone's volume (velocity) change. The further you raise this setting, the more easy it becomes to produce higher values for velocity.
PLAY FEEL		By selecting the Play Feel setting that's appropriate for your guitar/bass playing technique, you can obtain more naturally expressive dynamics.
	FEEL1–FEEL4	FEEL1 is the mode that gives sounds the broadest variation in volume based on the picking dynamics. As the setting number is increased, it becomes easier to produce high volume sounds even with weaker picking. This allows you to play with consistent volume, whether you tap the strings or use rough picking.
	NO DYNA	In this mode, sounds are played at a fixed volume regardless of the picking strength.
LOW VELO CUT	OFF, 1–10	Adjust this if simply touching a string causes a note to be unintentionally triggered. Raising this value will make it more difficult to trigger notes.
HOLD TYPE		This selects the way the Hold function works.
	HOLD1	Note On messages are held when the Hold function is switched on with the controller. If the Hold function remains on as you continue to play the strings, each successive Note On message is held, and when a Note message is already being played from the same string, the previous Note message is canceled, and the next Note On message is held. This allows you to prevent any interruption in the sounds, even sounds from releasing the strings over the frets.
	HOLD2	Note On messages are held when the Hold function is switched on with the controller. However, subsequent Note On messages are not output if you continue to play the instrument with the Hold effect left on.
	HOLD3	Note On messages are held when the Hold function is switched on with the controller. If the Hold function remains on as you continue to play the strings, Note On messages for strings other than the one already being held can be output, but they are not held.
CC1 SRC CC2 SRC	GK VOL, GK SW1, GK SW2, CTL1, CTL2, CTL3, CTL4, CTL5, CTL6, EXP1, EXP2	You can output the actions of the controllers specified with SRC as Control Change messages.

Parameter	Value	Explanation
CC1 CC# CC2 CC#	OFF, #1–#31, #64–#95	This sets the Control Change number to be output. When the MODE is set to POLY, messages are output only over the BASIC CH; when this is set to MONO, the messages are output over the six channels starting from the BASIC CH.
BANK MSB *1	OFF, 1–127	This sets the Bank Select (MSB). *1
STR1 BANK MSB–STR6 BANK MSB *2		
HiC BANK MSB–LoB BANK MSB *2		
BANK LSB *1	OFF, 1–127	This sets the Bank Select (LSB). *1
STR1 BANK LSB–STR6 BANK LSB *2		
HiC BANK LSB–LoB BANK LSB *2		
PC *1	OFF, 1–128	This sets the Program Number. *1
STR1 PC–STR6 PC *2		
HiC PC–LowB PC *2		

\*1 Setting available with MODE set to POLY.

\*2 Setting available with MODE set to MONO. This can be specified for each string.

## LED COLOR

You can specify the color of the LED for each footswitch.

[BANK▼]/[BANK▲] switch, [CTL1]/[CTL2] switch, [1]–[4] switch, CUR NUM

Parameter	Value	Explanation
OFF	Refer to "Value" (p. 80).	Specifies the color of the LED when the switch is not pressed.
ON	Refer to "Value" (p. 80).	Specifies the color of the LED when the switch is pressed.

\* CUR NUM indicates the number of the currently selected patch (current number).

### Value

Value	Explanation
OFF	The LED is not lit.
RED BLUE LIGHT BLUE GREEN YELLOW WHITE PURPLE	Specify the color of LED illumination.
AUTO	The illumination behavior and color that are appropriate for the footswitch function will be specified. If "ON" is set to AUTO, the OFF setting is ignored.
AUTO RED AUTO BLUE AUTO LIGHT BLUE AUTO GREEN AUTO YELLOW AUTO WHITE AUTO PURPLE	The illumination behavior that is appropriate for the footswitch function will be specified. You can specify the color. If "ON" is set to AUTO, the OFF setting is ignored.

## PREFERENCE

Value	Explanation
PATCH	Different settings can be made independently for each patch.
SYSTEM	The same settings will be shared by all patches.

# SYSTEM Parameters

## CONTROL MODE

The control mode setting lets you choose how you want to operate the effects.

Value	Explanation
<b>MEMORY</b>	<p>This mode lets you recall and use the patches that are saved in the unit (Memory mode).</p> <p>Use the [1]–[4] switches to switch patches.</p> <p>* Even in memory mode, you can select functions other than patch recall.</p>
<b>MANUAL</b>	<p>This mode lets you use the [1]–[4] switches to operate the functions that are assigned to them by each patch or by the settings for the entire system (Manual mode).</p> <p>When you select manual mode, a portion of the PLAY screen changes.</p> 

## IN/OUT SETTING

### GK SETTING

Here you can make settings for the divided pickup to ensure that the SY-1000 will always play optimally.

These settings must be made when you newly attach a divided pickup to a guitar (or a bass), or when you've adjusted the height of the divided pickup.

The SY-1000 can save ten sets of these settings (GK SETTING).

If you save the GK SETTING parameters for each of your guitars (basses), you can quickly recall the appropriate settings when you connect a different guitar (bass).

The GK SETTING parameters are saved even when you turn off the power. You need not make the settings each time you play the instrument.

Parameter	Value	Explanation	
<b>SETTING</b>	1–10	<p>Selects the GK SET used when EFFECTS parameters → MASTER parameters GK SET is set to "SYSTEM."</p> <p>The various parameters specified in GK SETTING are saved in the GK SET number that you select here.</p>	
<b>NAME</b>		Edits the name of the GK set (up to eight characters).	
<b>GK TYPE *1</b>	GK-3	Choose this when using a Roland GK-3.	
	GK-2A	Choose this when using a Roland GK-2A, or when using a guitar (commercially available) with a built-in divided pickup.	
	GC-1	Choose this when using a Roland V-Guitar GC-1.	
	PIEZO	Piezo pickup	(Flat response)
	PIEZO F		Fishman
	PIEZO G		Graph Tech
	PIEZO L		L.R. Baggs
PIEZO R	RMC		
<b>GK TYPE *2</b>	GK-3B	Choose this if you're using a GK-3B.	
	GK-2B	Choose this when using a Roland GK-2B, or when using a bass (commercially available) with a built-in divided pickup.	
	PIEZO	Piezo pickup	(Flat response)
	PIEZO G		Graph Tech
PIEZO R	RMC		
<b>SCALE *1</b>	500–660 mm, ST (648 mm), LP (628 mm)	Specify the scale length of the guitar you're using.	
<b>SCALE *2</b>	710–940 mm, SHORT (760 mm), MEDIUM (812 mm), LONG JB/PB (864 mm), EXTRA LONG (914 mm)	Specify the scale length of the bass you're using.	

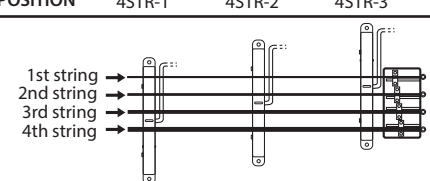
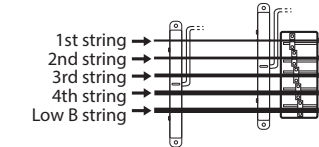
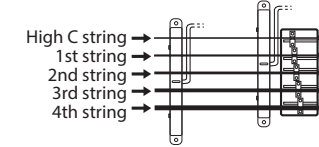
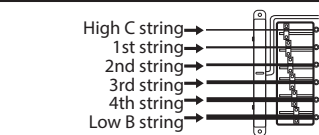
Parameter	Value	Explanation
<b>GK PU POSITION</b> *2	Specifies the position of the divided pickup.	
	Position for a 4-string bass. GK PU POSITION 4STR-1    4STR-2    4STR-3	
	Position for a 5-string bass (Low B–G). GK PU POSITION 5STR-Lo1    5STR-Lo2	
	Position for a 5-string bass (E–Hi C). GK PU POSITION 5STR-Hi1    5STR-Hi2	
	Position for a 6-string bass. GK PU POSITION 6STR	
<b>PU PHASE</b>	NORMAL, INVERSE	This sets the phase for the divided pickup and normal pickup. Set this to "NORMAL," and if the low-frequency range is cut, set this to "INVERSE."

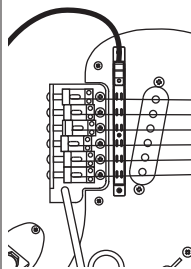
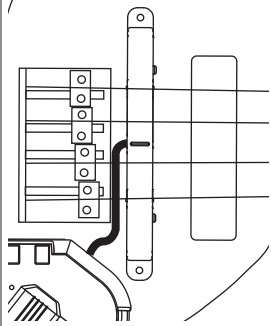
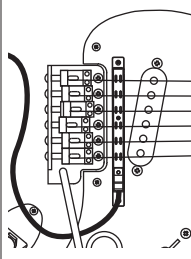
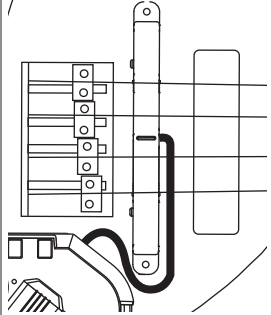
Parameter	Value	Explanation
<b>PU DIRECTION</b>		This sets the direction for the divided pickup's installation.
	NORMAL	<p>The cable extends from the side of the 6th string. (GUITAR MODE)</p>  <p>The cable extends from the side of the bass's bridge. (BASS MODE)</p> 
	REVERSE	<p>The cable extends from the side of the 1st string. (GUITAR MODE)</p>  <p>The cable extends from the side of the bass's neck. (BASS MODE)</p> 
<b>PIEZO TONE L</b> *3	-10 dB–+10 dB	Adjusts the low-frequency range.
<b>PIEZO TONE H</b> *3	-10 dB–+10 dB	Adjusts the high-frequency range.

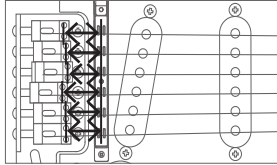
Parameter	Value	Explanation
SW POSITION	NORMAL, REVERSE	Swaps the functions of the [S1] and [S2] buttons of the GK-3, GK-2A, GK-3B, or GK-2B.
NORMAL PU GAIN	-20 dB~+20 dB	Adjusts the input level of the normal pickup. When making this setting, set the GK pickup's select switch to "MIX."
DISTANCE 1-DISTANCE 6	10.0~30.0 mm	Specifies the distance between the divided pickup and the bridge.
DISTANCE HiC-DISTANCE LowB	5.5~55.5 mm	 <p>* If the pickup type is set to "GC-1" or one of the piezo-type pickups, this setting is not necessary.</p>
SENS 1-SENS 6	0-100	Specifies the input sensitivity of the divided pickup.
SENS HiC-SENS LowB		

- \*1 Setting available with GUITAR MODE.
- \*2 Setting available with BASS MODE.
- \*3 Setting available when GK PU TYPE is PIEZO type.

## NORMAL SETTING

You can save ten types of settings for your conventional guitar (bass) as a NORMAL SETTING.

The NORMAL SETTING parameters are saved even when you turn off the power. You need not make the settings each time you play the instrument.

These settings are for the signal that is input to INST (DYNAMIC SYNTH), and apply to a NORMAL PATCH.

Parameter	Value	Explanation
SETTING	1-10	Selects the NORMAL SET used when EFFECTS parameters → MASTER parameters NORMAL SET is set to "SYSTEM." The various parameters specified in NORMAL SETTING are saved in the NORMAL SET number that you select here.
NAME	Edits the name of the NORMAL set (up to eight characters).	
COMPRESSOR SW	OFF, ON	Turns the compressor on/off.
ATTACK	0-100	Adjusts the strength of the attack when picking.
SUSTAIN	0-100	Adjusts the range (time) during which the decaying sound of the guitar/bass is amplified to a constant volume. Larger values will result in longer sustain.

Parameter	Value	Explanation
LEVEL	0-100	Adjusts the volume.
SENS	-50~+50	Adjusts the overall input sensitivity.
LOW	-50~+50	Adjusts the sensitivity of the low-frequency region. Increase this setting if you want to make the low-frequency region thicker. Decrease this setting if you want to make the low-frequency region clearer.
HIGH	-50~+50	Adjusts the sensitivity of the high-frequency region. Increase this setting if you want more volume in the high-frequency region, such as when soloing. Decrease this setting if you want to restrain the volume of the high-frequency region.

## MAIN OUT, SUB OUT

### OUTPUT SELECT&LEVEL

Specify the device (amp) that's connected to the MAIN OUTPUT, SUB OUTPUT jacks.

Parameter	Value	Explanation
STEREO LINK	OFF, ON	If this is ON, the L and R settings are made at the same time.

Parameter	Value	Explanation
L:MAIN OUTPUT SELECT R:MAIN OUTPUT SELECT L:SUB OUTPUT SELECT R:SUB OUTPUT SELECT	LINE/PHONES	Choose this setting if you're using headphones, or if the SY-1000 is connected to a keyboard amp, mixer, or digital recorder.
	JC-120 RETURN	Choose this setting if the SY-1000 is connected to the RETURN jack of the Roland JC-120 guitar amp.
	JC-120 INPUT	Choose this setting if the SY-1000 is connected to the guitar input of a JC-120 guitar amp.
	COMBO AMP 1 RETURN	Use this setting when connecting to the RETURN of a combo-type guitar amp (in which the amp and speakers are in a single unit) equipped with one speaker.
	COMBO AMP 1 INPUT	Use this setting when connecting to the guitar input of a combo-type amp (in which the amp and speakers are in a single unit) equipped with one speaker.
	COMBO AMP 2 RETURN	Use this setting when connecting to the RETURN of a combo-type amp (in which the amp and speakers are in a single unit) equipped with two speakers.
	COMBO AMP 2 INPUT	Use this setting when connecting to the guitar input of a combo-type amp (in which the amp and speakers are in a single unit) equipped with two speakers.
	STACK AMP RETURN	Use this setting when connecting to the RETURN of a stack-type amp (in which the amp and speaker are in separate units).
	STACK AMP INPUT	Use this setting when connecting to the guitar input of a stack-type amp (in which the amp and speaker are in separate units).
	BASS AMP WITH TWEETER	Use this setting when connecting to a bass amp that has a tweeter.
	BASS AMP NO TWEETER	Use this setting when connecting to a bass amp that does not have a tweeter. The high-frequency range will be corrected.
	L:MAIN OUTPUT LEVEL R:MAIN OUTPUT LEVEL L:SUB OUTPUT LEVEL R:SUB OUTPUT LEVEL	0-200

## GLOBAL EQ

This adjusts the tone of the OUTPUT regardless of the equalizer on/off settings of individual patches.

Parameter	Value	Explanation
STEREO LINK	OFF, ON	If this is ON, the L and R settings are made at the same time.
LOW CUT *1	FLAT, 20.0 Hz-16.0 kHz	This sets the frequency at which the low cut filter begins to take effect. When FLAT is selected, the low cut filter will have no effect.
L: LOW CUT *2		
R: LOW CUT *2		
LOW GAIN *1	-20-+20 dB	Adjusts the tone for the low frequency range.
L: LOW GAIN *2		
R: LOW GAIN *2		
LOW-MID FREQ *1	20.0 Hz-16.0 kHz	Specifies the center of the frequency range that will be adjusted by the LOW-MID GAIN.
L: LOW-MID FREQ *2		
R: LOW-MID FREQ *2		
LOW-MID Q *1	0.5-16	Adjusts the width of the area affected by the EQ centered at the LOW-MID FREQ. Higher values will narrow the area.
L: LOW-MID Q *2		
R: LOW-MID Q *2		
LOW-MID GAIN *1	-20-+20 dB	Adjusts the tone for the low-middle frequency range.
L: LOW-MID GAIN *2		
R: LOW-MID GAIN *2		
HIGH-MID FREQ *1	20.0Hz-16.0kHz	Specifies the center of the frequency range that will be adjusted by the HIGH-MID GAIN.
L: HIGH-MID FREQ *2		
R: HIGH-MID FREQ *2		
HIGH-MID Q *1	0.5-16	Adjusts the width of the area affected by the EQ centered at the HIGH-MID FREQ. Higher values will narrow the area.
L: HIGH-MID Q *2		
R: HIGH-MID Q *2		

Parameter	Value	Explanation
HIGH-MID GAIN *1	-20~+20 dB	Adjusts the tone for the high-middle frequency range.
L: HIGH-MID GAIN *2		
R: HIGH-MID GAIN *2		
HIGH GAIN *1	-20~+20 dB	Adjusts the tone for the high frequency range.
L: HIGH GAIN *2		
R: HIGH GAIN *2		
HIGH CUT *1	20.0Hz– 16.0kHz FLAT	This sets the frequency at which the high cut filter begins to take effect. When FLAT is selected, the high cut filter will have no effect.
L: HIGH CUT *2		
R: HIGH CUT *2		

\*1 Valid when the STEREO LINK is set to ON.  
\*2 Valid when the STEREO LINK is set to OFF.

## TOTAL

These parameters control the threshold level of the noise suppressor used by each patch, the overall reverb level, and the overall output. This does not affect the settings of each patch.

Parameter	Value	Explanation
TOTAL REVERB LEVEL	0%–200%	Adjusts the reverb level specified for each patch.  It is useful to adjust the reverb level appropriately for the space in which you're performing. This does not affect the settings of each patch. * If you want to use the settings specified for each patch, set this to 100%.
TOTAL NS THRESHOLD	-20 dB~+20 dB	Control the threshold level of the noise suppressor used by each patch.  It is effective to adjust this when you switch to connecting a different guitar, or according to the amount of noise in the performance venue. This does not affect the settings of each patch. * If you want to use the settings specified for each patch, set this to 0 dB.

## USB AUDIO

Here you can make USB-related settings for when the SY-1000 is connected to a computer via USB.

Parameter	Value	Explanation
MAIN MIX LEVEL	0–100	Adjusts the level of the sound that is input from the computer.
SUB MIX LEVEL	0–100	Adjusts the level of the sound that is input from the computer.
IN LEVEL	0–100	Adjusts the level of the sound that is input from the computer.
OUT LEVEL	0–100	Adjusts the level of the sound that is output to the computer.
AUDIO ROUTING *1 *2		Specifies the routing for USB audio. You can record the sound of the SY-1000 into your DAW, play back the recorded sound from your DAW and monitor it on the SY-1000, or re-synth your recording. Refer to "AUDIO ROUTING" (p. 86).
IN POSITION *1	INST1, INST2, INST3, NORMAL IN, BALANCER1, BALANCER2, BALANCER3, MAIN OUT, SUB OUT, MAIN&SUB	This sets the point at which digital audio signals received via USB (from your computer) are connected within the SY-1000.
OUT POSITION *2 *3	INST1, INST2, INST3, NORMAL IN, BALANCER1, BALANCER2, BALANCER3, MAIN OUT, SUB OUT	This specifies the point at which digital audio signals are taken from inside the SY-1000 and sent via USB (to your computer).

- \*1 INST1–INST3, NORMAL IN, and BALANCER1–BALANCER3 are valid when the AUDIO ROUTING is set to RE-SYNTH1. And, MAIN OUT, SUB OUT, and MAIN&SUB are valid when the AUDIO ROUTING is set to other than RE-SYNTH1.
- \*2 When the AUDIO ROUTING is set to MIX, only MAIN OUT and SUB OUT are valid.
- \*3 NORMAL IN is valid when the AUDIO ROUTING is set to STANDARD or DIRECT OFF.

## What is resynthesis?

This is a technique in which the original sound unprocessed by an INST or effects is recorded into your DAW, and then you later use the INST sounds and effects to design your sound. This gives you the freedom to change the sound after you've finished recording.

AUDIO ROUTING

Value	Explanation
STANDARD	<p>Use this setting if you want to play your guitar while playing back a backing song from your computer. The sound of the SY-1000 and the backing from your computer are mixed and output from the SY-1000's OUTPUT.</p> <p>The sound of only the SY-1000 is output from the SY-1000's USB port.</p>
MIX	<p>Use this setting if you want to play your guitar while playing back a song from your computer. The sound of the SY-1000 and the backing are mixed and output from the SY-1000's OUTPUT and from the USB port.</p>
RE-SYNTH1	<p>Use this setting if the sound unprocessed by an INST and effects is being played back from the computer and input to the SY-1000 for resynthesis.</p>
RE-SYNTH2	<p>Use this setting if the sound unprocessed by an INST and effects is being resynthesized while the computer plays a backing song.</p>

Value	Explanation
DIRECT OFF	<p>Use this setting if you want the output processed by a plug-in effect on your DAW to be output to the SY-1000's OUTPUT.</p> <p>Only the sound of the SY-1000 is output from the SY-1000's USB port.</p>

## HARDWARE SETTING

### KNOB SETTING

Parameter	Value	Explanation
<b>KNOB 1–KNOB 6</b>		Here you can assign the desired parameters to the [1]–[6] knobs in the Play screen. * The settings you make here are only for the knobs in the Play screen.
<b>KNOB LOCK</b>	OFF, ON	If this is ON, knob operations in the Play screen will be disabled.
<b>OUTPUT LEVEL KNOB</b>		Selects the output(s) whose volume is adjusted by the OUTPUT LEVEL knob.
	MAIN	Adjusts only the level of the MAIN OUTPUT.
	SUB	Adjusts only the level of the SUB OUTPUT.
	MAIN+SUB	Simultaneously adjusts the level of both the MAIN OUTPUT and SUB OUTPUT.

### KNOB 1–KNOB 6

Category	Parameter
<b>PATCH</b>	PATCH SELECT
<b>TUNER</b>	ON/OFF
<b>MASTER</b>	BPM
	KEY
	PATCH LEVEL
<b>CONTROL MODE</b>	CONTROL MODE
<b>INPUT SETTING</b>	GK SET
	NORMAL SET
<b>OUTPUT SETTING</b>	MAIN OUTPUT-L LEVEL
	MAIN OUTPUT-R LEVEL
	MAIN OUTPUT-L SELECT
	MAIN OUTPUT-R SELECT
	SUB OUTPUT-L LEVEL
	SUB OUTPUT-R LEVEL
	SUB OUTPUT-L SELECT
	SUB OUTPUT-R SELECT
<b>TOTAL</b>	TOTAL REVERB LEVEL
	TOTAL NS THRESHOLD
<b>MAIN GLOBAL EQ L/S MAIN GLOBAL EQ R</b>	LOW CUT
	LOW GAIN
	LOW-MID FREQ
	LOW-MID Q
	LOW-MID GAIN
	HIGH-MID FREQ
	HIGH-MID Q
	HIGH-MID GAIN
	HIGH GAIN
	HIGH CUT

Category	Parameter
<b>SUB GLOBAL EQ L/S SUB GLOBAL EQ R</b>	LOW CUT
	LOW GAIN
	LOW-MID FREQ
	LOW-MID Q
	LOW-MID GAIN
	HIGH-MID FREQ
	HIGH-MID Q
	HIGH-MID GAIN
	HIGH GAIN
	HIGH CUT
<b>USB AUDIO</b>	MAIN MIX LEVEL
	SUB MIX LEVEL
	IN LEVEL
	OUT LEVEL
	AUDIO ROUTING
	IN POSITION OUT POSITION
<b>GUITAR TO MIDI *1</b>	GUITAR TO MIDI SW
<b>BASS TO MIDI *2</b>	BASS TO MIDI SW

\*1 Setting available with GUITAR MODE.

\*2 Setting available with BASS MODE.

### ASSIGN HOLD

Parameter	Value	Explanation
<b>GK VOL HOLD EXP1 HOLD EXP2 HOLD</b>	OFF	When you switch patches, the values of GK VOL, EXP1, and EXP2 are set to the values saved in the patch.
	ON	When you switch patches, the values of the parameters assigned to GK VOL, EXP1, and EXP2 maintain their values if the parameters have the same assignments as in the previously-selected patch. For example, if the EXP1 parameter was “FV1” both for the current patch and for the previously-selected patch, the value of EXP1 is maintained even when you switch patches. (The FV1 value saved in the newly-selected patch is ignored.)

### GROUND LIFT

Parameter	Value	Explanation
<b>GROUND LIFT</b>	OFF, ON	Turns GROUND LIFT on/off for the RETURN jack.

## OTHER

Parameter	Value	Explanation
AUTO OFF		The SY-1000 can turn off its power automatically. If you want to have the power remain on all the time, turn it "OFF." * With the factory settings, this function is turned "ON." * When the power is turned off, any settings you were editing will be lost. You must save settings that you want to keep.
	OFF	The power will not turn off automatically.
	ON	The power will turn off automatically when 10 hours have passed since you last played or operated the unit. The display will show a message approximately 15 minutes before the power turns off.
LCD CONTRAST	1-10	Here you can adjust the brightness of the characters in the display.

## PLAY OPTION

Here you can specify how the pedals will work during performance.

Parameter	Value	Explanation
BANK MODE	WAIT	When you press a bank pedal to switch banks, the indication in the display will change but the patch does not yet change at this time. When you press a number pedal, the bank and number are finalized, and the next patch is selected.
	IMMED	The patch switches instantly when a BANK pedal or any of the number pedals is pressed.
BANK EXTENT MIN	U01-U50 P01-P50	Sets the lower limit for the banks.
BANK EXTENT MAX	U01-U50 P01-P50	Sets the upper limit for the banks.
BANK DOWN & UP SW	OFF, TUNER	Turns on/off the function that switches to the TUNER when the BANK [▼] and BANK [▲] switches are pressed simultaneously.

## MIDI

On the SY-1000, you can use MIDI to perform the following operations.

### Operations from the SY-1000

What you can do	Explanation
<b>Transmit program change messages</b>	When you select a patch on the SY-1000, the program change message specified by the PATCH MIDI setting or the program change message corresponding to the selected patch number is transmitted. The external MIDI device that receives this program change message will switch to the corresponding settings.
<b>Transmit control change messages</b>	Operations of the [CTL1] or [CTL2] switch, a foot switch or expression pedal connected to the CTL3,4/EXP1 or CTL5,6/EXP2 jack, the [S1] or [S2] buttons of the divided pickup, or the GK volume are transmitted as control change messages. These messages can control parameters on an external MIDI device.
<b>Outputting Performance Data</b>	Performance data of the guitar (bass) is transmitted as note messages and bend messages. You can use this to play a connected synthesizer sound module. For detailed information, refer to "GUITAR TO MIDI/BASS TO MIDI" (p. 79).
<b>Transmitting Data</b>	Parameter settings stored in the SY-1000 can be transmitted as exclusive messages to another MIDI device. This allows you to give another SY-1000 the identical settings and to save parameter settings to MIDI sequencers and other such devices.

### Operations from an External MIDI Device

What you can do	Explanation
<b>Switching Patch Numbers</b>	Program change messages can be received from an external MIDI device. SY-1000 patches can be switched from an external MIDI device.
<b>Receive control change messages</b>	Control change messages can be received from an external MIDI device. SY-1000 parameters can be controlled from an external MIDI device.
<b>Receiving Data</b>	The SY-1000 can receive data that is transmitted from another SY-1000 unit, or data that was saved on a MIDI sequencer. All of the SY-1000's parameters can be changed in a single operation.

## MIDI SETTING

Parameter	Value	Explanation
<b>RX CHANNEL</b>	This sets the MIDI channel used for receiving MIDI messages.	
	Ch. 1– Ch. 16	Specifies the receive channel.

Parameter	Value	Explanation
<b>OMNI MODE</b>	This makes the settings for the channels used for MIDI information.	
	OFF	Information is received on the channel specified by the RX CHANNEL setting.
	ON	Messages are received on all channels, regardless of the MIDI channel settings.
<b>TX CHANNEL</b>	Sets the MIDI channel used for transmitting MIDI messages.	
	Ch. 1– Ch. 16.	Specifies the transmit channel.
	RX	Transmits on the same channel as the RX CHANNEL.
<b>DEVICE ID</b>	This sets the MIDI Device ID used for transmitting and receiving Exclusive messages.	
	1–32	Sets the MIDI Device ID.
<b>MIDI IN THRU</b>	This specifies the connector from which to output the MIDI messages that are received at the MIDI IN connector.	
	OFF	MIDI messages are not transmitted.
	MIDI OUT	Messages are transmitted from the MIDI OUT connector.
	USB OUT	Messages are transmitted from the USB port.
	USB/MIDI	Messages are transmitted from the USB port and the MIDI OUT connector.
<b>USB IN THRU</b>	This specifies the connector from which to output the MIDI messages that are received at the USB port.	
	OFF	MIDI messages are not transmitted.
	MIDI OUT	Messages are transmitted from the MIDI OUT connector.
	USB OUT	Messages are transmitted from the USB port.
	USB/MIDI	Messages are transmitted from the USB port and the MIDI OUT connector.

Parameter	Value	Explanation
SYNC CLOCK		This setting determines the basis used for synchronizing the timing for effect modulation rates and other time-based parameters. * If SYNC CLOCK is set to AUTO, MIDI (AUTO), or USB (AUTO), and an external MIDI device is connected, this unit synchronizes to the tempo of the external MIDI device. In this case, the patch's BPM parameter (p. 66) is ignored. If you want this unit's BPM setting to be the reference (i.e., if you want to enable the BPM parameter), set SYNC CLOCK to "INTERNAL." * When synchronizing performances to the MIDI Clock signal from an external MIDI device, timing problems in the performance may occur due to errors in the MIDI Clock.
	AUTO	Operations are synchronized to MIDI clock messages received via MIDI or USB. However, operations are automatically synchronized to the SY-1000's internal Clock if the SY-1000 is unable to receive the external Clock.
	INTERNAL	Operations are synchronized to the SY-1000's internal Clock.
	MIDI (AUTO)	Operations are synchronized to the MIDI Clock received via MIDI. However, operations are automatically synchronized to the SY-1000's internal Clock if the SY-1000 is unable to receive the external Clock.
	USB (AUTO)	Operations are synchronized to the USB Clock received via USB. However, operations are automatically synchronized to the SY-1000's internal Clock if the SY-1000 is unable to receive the external Clock.
CLOCK OUT		Specifies whether MIDI clock will be output from the SY-1000.
	OFF	MIDI clock is not output.
	ON	MIDI clock is output.
PC OUT		This setting determines whether or not Program Change messages are output when the SY-1000's patches are switched.
	OFF	MIDI messages for PATCH MIDI are not transmitted (PATCH MIDI control change messages are not transmitted either).
	ON	Transmit program change messages.
TX PC MAP		This sets the Program Change messages transmitted when patches are switched.
	FIX	Regardless of the patch settings, Program Change messages predetermined for each patch number are sent.
	PATCH MIDI	The MIDI messages specified by the PATCH MIDI settings of each patch are transmitted (including control change messages).

Parameter	Value	Explanation
RX PC MAP		When the SY-1000 receives a program change message, you can specify whether the SY-1000 switches to the patch corresponding to the received program change message or to the patch specified by the "PROGRAM MAP BANK1-BANK4" (p. 90).
	FIX	Switch to the patch corresponding to the received program change message. "PROGRAM MAP BANK1-BANK4" (p. 90) is ignored.
	PROG	The patch specified by "PROGRAM MAP BANK1-BANK4" (p. 90) will be selected.
NUM1 CC#		Specifies the controller number when transmitting pedal operations as control change messages. Control Change messages are not output. Pedal operations are transmitted using the specified controller number.
NUM2 CC#		
NUM3 CC#	OFF	
NUM4 CC#		
BANK DOWN CC#		
BANK UP CC#		
CTL1 CC#		
CTL2 CC#		
CTL3 CC#		
CTL4 CC#		
CTL5 CC#		
CTL6 CC#		
EXP1 CC#		
EXP2 CC#		
GK VOL CC#		
GK SW1 CC#		
GK SW2 CC#		

### PROGRAM MAP BANK1-BANK4

When switching patches using Program Change messages transmitted by an external MIDI device, you can freely set the correspondence between Program Change messages received by the SY-1000 and the patches to be switched to.

Parameter	Value	Explanation
PC#1-PC#128	U01-1-U50-4, P01-1-P50-4	This sets the patch number (U01-1 through P50-4) for the corresponding Program Change messages.

### BULK DUMP

By transmitting exclusive data, you can send the same settings to another SY-1000 unit, or save effect settings on your MIDI sequencer.

Parameter	Value	Explanation
FROM TO	SYSTEM	System parameter settings
	U01-1-U50-4	Settings for Patch Number U01-1 through U50-4
	VARIATION	Contents of the variation settings
	TEMP	Settings for the patch that is currently selected

**MEMO**

If you are using the Bulk Dump function to send the same settings to another SY-1000 unit, set both units to the same MODE.

You can't perform a bulk dump between two SY-1000 units whose MODE differs (one SY-1000 operating in GUITAR MODE and another SY-1000 operating in BASS MODE).

**GUITAR TO MIDI/BASS TO MIDI**

Parameter	Value	Explanation
<b>ON/OFF</b>	OFF, ON	Switches on/off the GUITAR TO MIDI/BASS TO MIDI function. If this is OFF, no MIDI messages related to GUITAR TO MIDI/BASS TO MIDI are transmitted.
<b>HOLD CTL</b>	GK SW1, GK SW2, CTL1, CTL2, CTL3, CTL4, CTL5, CTL6	This setting determines the controller used for the HOLD function.
<b>BEND THIN</b>	OFF, ON	Setting this to ON thins out the Pitch Bend messages and reduces the volume of MIDI data.
<b>BEND RANGE</b>	0-24	Specifies the maximum range of change for pitch bend messages.
<b>BASIC CH</b>	1-11	Specifies the MIDI transmit channel used by the GUITAR TO MIDI/BASS TO MIDI function.
<b>PC MASK</b>	OFF, ON	When set to ON, the Bank Select messages and Program Change messages used for the GUITAR TO MIDI/BASS TO MIDI function are not transmitted when patches are changed.

**TUNER**

The SY-1000's tuner function provides two modes: single mode (SINGLE MODE) lets you tune one string at a time, and multi mode (MULTI MODE) can detect the pitch of six strings simultaneously.

In the TUNER screen, you can use the [◀] [▶] (PAGE) buttons to switch modes.

**TUNER MODE**

Parameter	Value	Explanation
<b>TUNER MODE</b>	MULTI MODE	Allows you to tune six strings at the same time. * Setting available with GK PATCH.
	SINGLE MODE	Allows you to tune by playing a single note on the specific string you're tuning.
<b>PITCH</b>	435-445 Hz	Specifies the reference pitch.
<b>OUTPUT</b>	MUTE	Sound will not be output while tuning.
	BYPASS	While tuning, the sound of the guitar being input to the SY-1000 will be output without change. All INST and effects are off.
	THRU	Allows you to tune while outputting the sound of the current patch. * If ALT TUNE is on, the sound processed by the ALT TUNE effect is output.

## FACTORY RESET

Initializes the SY-1000 to its factory-set condition.

### MEMO

Only the currently selected mode is initialized. (If you execute Factory Reset while in GUITAR MODE, the settings of BASS MODE are not initialized.)

Parameter	Value	Explanation
FROM, TO	SYSTEM	System parameter settings
	U01-1–U50-4	Settings for Patch Number U01-1 through U50-4
	VARIATION	Contents of the variation settings

## MODE SETTING

Here you can specify whether you're using the SY-1000 with a guitar connected or with a bass connected.

Choose GUITAR MODE (GUITAR) if you're using it with a guitar, or choose BASS MODE (BASS) if you're using it with a bass.

### MEMO

- With the factory settings, this is set to "GUITAR."
- The SY-1000 starts up in the selected mode until you switch the mode again.
- Some parameters are shown differently depending on the selected mode.
- Patches are saved independently for GUITAR MODE and for BASS MODE.

# Saving a Sound (WRITE)

## Saving a Patch (PATCH WRITE)

If you save the INST settings and effect settings as a patch, you'll be able to recall them whenever you like.

If you select a different patch or turn off the power after editing the settings, edited settings will be lost. If you want to keep the data, you must save it.

### 1. Press the [WRITE] button.



### 2. Press the [1] knob to select "WRITE" (PATCH WRITE).



### 3. Use the [1] knob to select the save-destination (U01-1–U50-4).

You can use the [3]–[6] knobs to edit the name.

### Editing a name

To edit the patch name, use the [6] knob to move the cursor and use the [5] knob to change the character.

Controller	Function
Turn the [3] knob	Selects the type of characters
Press the [3] knob	Delete one character (delete)
Turn the [4] knob	Switch uppercase/lowercase
Press the [4] knob	Insert one space (insert)
Turn the [5] knob	Changes the character
Turn the [6] knob	Moves the cursor

### 4. Press the [WRITE] button to save.

The patch is written.

If you decide to cancel the operation, press the [4] knob.

## Exchanging Patches (PATCH EXCHANGE)

On the SY-1000, you can "swap" or exchange the positions of two User patches.

1. Select the exchange source patch.
2. Press the [WRITE] button.
3. Press the [2] knob to select "EXCHANGE" (PATCH EXCHANGE).
4. Use the [1] knob to select the other user patch that you want to exchange.



\* If you decide to cancel without exchanging, press the [EXIT] button a several times. You'll be returned to the Play screen.

### 5. Press the [WRITE] button once again.

A confirmation message appears.



### 6. Press the [6] knob.

The patches will be exchanged. If you decide to cancel the exchange operation, press the [5] knob.

## Initializing Patches (PATCH INITIALIZE)

You can return (initialize) a User patch to its original factory settings. This is convenient when you want to create a new patch from scratch.

### CAUTION

Any tone settings you've stored in a patch are lost once the initialization is executed.

1. Press the [WRITE] button.
2. Press the [3] knob to select "INITIALIZE" (PATCH INITIALIZE).
3. Use the [1] knob to select the user patch that you want to initialize. Use the [2] knob to select the type of patch.



- \* If you decide to cancel without initializing, press the [EXIT] button a several times. You'll be returned to the Play screen.
- \* The patch type can also be switched even after initialization. For details, refer to the EFFECTS section's explanation of INPUT block "PATCH TYPE" (p. 66).

4. Press the [WRITE] button once again.

A confirmation message appears.



5. Press the [6] knob.

The patch will be initialized. If you decide to cancel the initialize operation, press the [5] knob.

## Inserting a Patch (PATCH INSERT)

You can insert a patch into any position of the user patches.

For example, if you insert patch U01-1 at U02-1, patch U02-1 and subsequent patches are shifted (renumbered) backward by one. (Patch U02-1 becomes U02-2.)

### CAUTION

When you execute the insert operation, the last user patch (U50-4) is deleted.

1. Press the [WRITE] button.
2. Press the [4] knob to select "INSERT" (PATCH INSERT).
3. Use the [1] knob to select the insert-destination user patch.



- \* If you decide to cancel without inserting, press the [EXIT] button a several times. You'll be returned to the Play screen.

4. Press the [WRITE] button once again.

A confirmation message appears.



5. Press the [6] knob.

The patch is inserted at the specified position. If you decide to cancel the insert operation, press the [5] knob.

# Connecting to a Computer

By connecting the SY-1000 to a computer via USB, you can do the following.



- Transmit and receive digital audio signals and MIDI messages between the computer and the SY-1000.
- Edit and manage patches using the dedicated software
- Download patches from our dedicated BOSS TONE CENTRAL (<http://bosstonecentral.com/>) website  
➔ <http://bosstonecentral.com/>

## Installing the USB Driver

**You must install the USB driver before connecting to a computer.**

Please download the USB driver from the website shown below. Install this special driver before making a USB connection. For further details, refer to the Readme.htm file that comes with the download.

<https://www.boss.info/global/support/>

The program you need to use, and the steps you need to take to install the USB driver will differ depending on your computer setup, so please carefully read and refer to the Readme.htm file that comes with the download.

## Using the SY-1000 as an Audio Interface

You can record the sound of the SY-1000 on your computer, or have sound from your computer be output from the SY-1000's MAIN OUTPUT jacks or SUB OUTPUT jacks.

- \* For details of the audio signal flow when connected via USB and instructions on how to make settings, refer to "SY-1000 Parameter Guide" (PDF file).
- \* Refer to the instruction manual for the software you are using to learn how to switch the input source of the software.

## Making use of the SY-1000's dedicated software

Download the dedicated tool from the BOSS website. For details on how to use the software, refer to the Readme.htm file that comes with the download.

<https://www.boss.info/global/support/>

Using the dedicated software allows you to do the following:

- Easily download patches from our BOSS TONE CENTRAL website.
- Edit patch settings
- Name patches
- Organize patches in order and switch them around
- Back up patches and system settings, and return to the backed up settings

# Troubleshooting

## When Using the SY-1000 on Its Own

Problem	Items to check	Action
No sound/Low volume	Is the [OUTPUT LEVEL] knob turned down completely?	Adjust the knob to an appropriate setting.
	Could the volume of the GK pickup be turned down?	Raise the volume of the GK pickup to an appropriate level.
	Could the select switch of the GK pickup be set to "GUITAR"?	Set the switch of the GK pickup to "MIX."
	Could the PATCH LEVEL be turned down?	Raise the PATCH LEVEL.
	Are the SY-1000 and other devices connected properly?	Check the connections with the other devices.
	Is the power to the connected amp or mixer not turned on, or is the volume turned down?	Check the settings for the connected device.
	Is there a short in any connecting cable?	Try replacing the connecting cable.
	If there are no sounds through USB, are the [SYSTEM] - USB AUDIO settings correct?	Adjust the settings to the appropriate values.
Volume is uneven among the strings	Was the GK pickup sensitivity setting adjusted correctly for each string?	Perform the adjustment.
	Is the GK pickup attached correctly?	Refer to the manual of your GK pickup, and attach the GK pickup correctly.
When using the SY-1000's expression pedal, the result is different for each patch	The effect produced using the expression pedal is different for each sound (patch).	Check the effect of each patch beforehand.
Oscillation occurs	Are any gain values or volume-related parameter values in the effect settings set too high?	Decrease the value.
	Are any feedback values in the effect settings such as DELAY set too high?	Decrease the value.
Patches not switching	Is some screen other than the Play screen shown in the display?	With the SY-1000, you cannot switch patches in any screen other than the Play screen. Press the [EXIT] button one or more times to return to the Play screen.
Knobs don't work	Could the system parameter KNOB LOCK be "ON"?	Turn the system parameter KNOB LOCK "OFF."
Can't enter Tuner mode	Could the system parameter BANKDOWN&UP SW (TUNER) be "OFF"?	Turn the system parameter BANKDOWN&UP SW (TUNER) "ON."

## When Connected to a MIDI Device or Computer

Problem	Items to check	Action
The external sound module connected to the MIDI OUT connector does not sound	Do the MIDI channels of the transmitting and receiving devices match?	Match the MIDI channels.
	Could you have turned down the volume using the volume control of the GK pickup or the expression pedal?	Raise the volume.
Only one string sounds on the external sound module (some strings do not sound)	Could you be using Mono mode to transmit from the SY-1000 to a sound module that is unable to receive six MIDI channels simultaneously?	Use a sound module that supports multitimbral operation. Use the SY-1000 in Poly mode.
Pitch is incorrect (different than the guitar pitch)	Is the Bend Range of your external sound module set to +/- 24?	Set the Bend Range of your external sound module to +/- 24.
	Is your guitar tuned accurately?	Tune your guitar accurately.
When you view the note messages recorded in your sequencer, the pitches differ from what is actually sounded	The SY-1000 expresses the pitch as a combination of note data and pitchbend data. This means that if you're looking only at the note data, the pitches may appear different than what you played.	Check the pitchbend data.
MIDI messages not being transmitted/received Pitch does not change smoothly	Could there be a short in the MIDI cable?	Try replacing the MIDI cable.
	Are the SY-1000 and the external MIDI device connected properly?	Check the connection with the external MIDI device.
	Are the MIDI channels matched?	Check to confirm that both devices are set to the same MIDI channel.
	If you are transmitting from the SY-1000, have the settings for transmission been made?	Check the Program Change message transmission ON/OFF setting and the settings for the controller number to be transmitted.
	In CTL, check the GUITAR TO MIDI/BASS TO MIDI setting CHROMATIC.	If this is set to "TYPE2" or "TYPE3," pitch bend data will not be output, and the pitch will change in semitone steps. Set the CHROMATIC setting to "OFF" or "TYPE1."

# Block Diagram

## When Using a GK PATCH

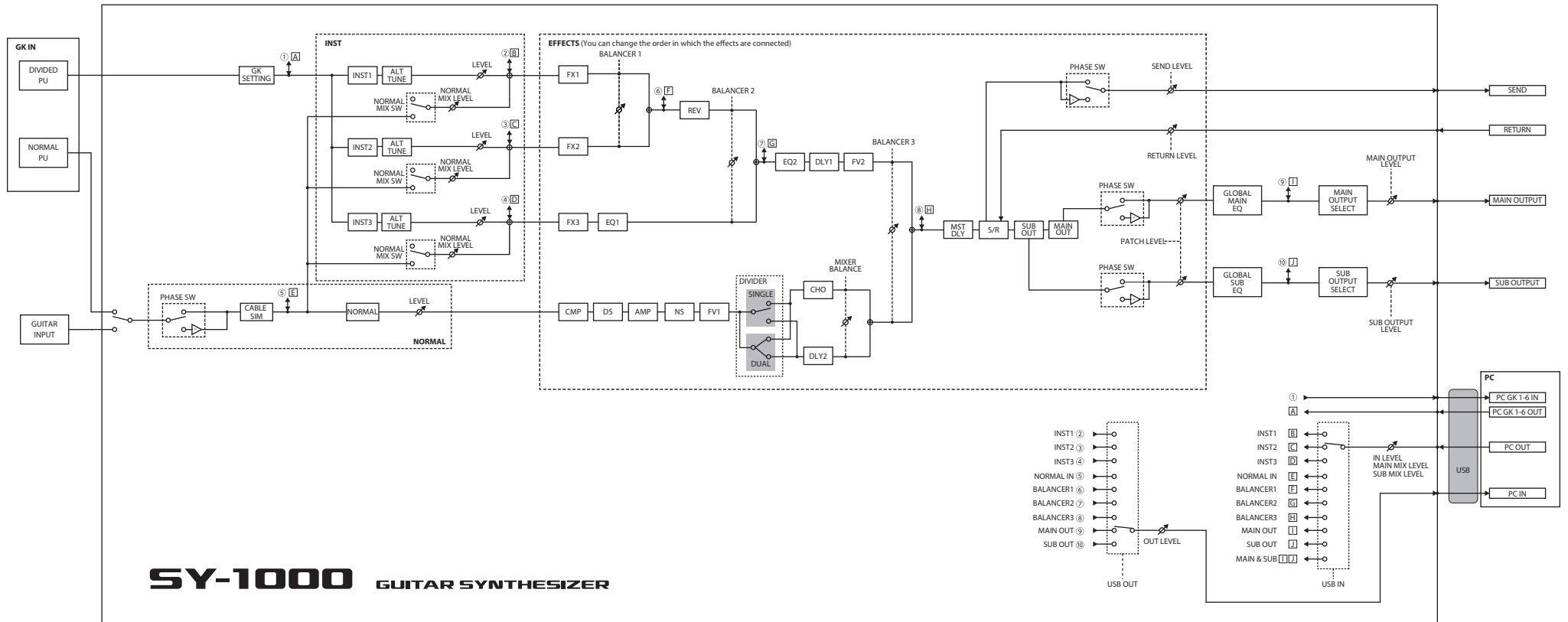

# When Using a NORMAL PATCH

