



V·Piano

Owner's Manual

WARNING: To reduce the risk of fire or electric shock, do not expose this apparatus to rain or moisture.

 CAUTION RISK OF ELECTRIC SHOCK DO NOT OPEN	
ATTENTION: RISQUE DE CHOC ELECTRIQUE NE PAS OUVRIR	
CAUTION: TO REDUCE THE RISK OF ELECTRIC SHOCK, DO NOT REMOVE COVER (OR BACK). NO USER-SERVICEABLE PARTS INSIDE. REFER SERVICING TO QUALIFIED SERVICE PERSONNEL.	



The lightning flash with arrowhead symbol, within an equilateral triangle, is intended to alert the user to the presence of uninsulated "dangerous voltage" within the product's enclosure that may be of sufficient magnitude to constitute a risk of electric shock to persons.



The exclamation point within an equilateral triangle is intended to alert the user to the presence of important operating and maintenance (servicing) instructions in the literature accompanying the product.

INSTRUCTIONS PERTAINING TO A RISK OF FIRE, ELECTRIC SHOCK, OR INJURY TO PERSONS.

IMPORTANT SAFETY INSTRUCTIONS SAVE THESE INSTRUCTIONS

WARNING - When using electric products, basic precautions should always be followed, including the following:

1. Read these instructions.
2. Keep these instructions.
3. Heed all warnings.
4. Follow all instructions.
5. Do not use this apparatus near water.
6. Clean only with a dry cloth.
7. Do not block any of the ventilation openings. Install in accordance with the manufacturers instructions.
8. Do not install near any heat sources such as radiators, heat registers, stoves, or other apparatus (including amplifiers) that produce heat.
9. Do not defeat the safety purpose of the polarized or grounding-type plug. A polarized plug has two blades with one wider than the other. A grounding type plug has two blades and a third grounding prong. The wide blade or the third prong are provided for your safety. If the provided plug does not fit into your outlet, consult an electrician for replacement of the obsolete outlet.
10. Protect the power cord from being walked on or pinched particularly at plugs, convenience receptacles, and the point where they exit from the apparatus.
11. Only use attachments/accessories specified by the manufacturer.
12. Use only with the cart, stand, tripod, bracket, or table specified by the manufacturer, or sold with the apparatus. When a cart is used, use caution when moving the cart/apparatus combination to avoid injury from tip-over.
13. Unplug this apparatus during lightning storms or when unused for long periods of time.
14. Refer all servicing to qualified service personnel. Servicing is required when the apparatus has been damaged in any way, such as power-supply cord or plug is damaged, liquid has been spilled or objects have fallen into the apparatus, the apparatus has been exposed to rain or moisture, does not operate normally, or has been dropped.



For the U.K.

WARNING: THIS APPARATUS MUST BE EARTHED

IMPORTANT: THE WIRES IN THIS MAINS LEAD ARE COLOURED IN ACCORDANCE WITH THE FOLLOWING CODE.
GREEN-AND-YELLOW: EARTH, BLUE: NEUTRAL, BROWN: LIVE

As the colours of the wires in the mains lead of this apparatus may not correspond with the coloured markings identifying the terminals in your plug, proceed as follows:

The wire which is coloured GREEN-AND-YELLOW must be connected to the terminal in the plug which is marked by the letter E or by the safety earth symbol  or coloured GREEN or GREEN-AND-YELLOW.

The wire which is coloured BLUE must be connected to the terminal which is marked with the letter N or coloured BLACK.

The wire which is coloured BROWN must be connected to the terminal which is marked with the letter L or coloured RED.

Before using this unit, carefully read the sections entitled: "IMPORTANT SAFETY INSTRUCTIONS", "USING THE UNIT SAFELY" (p. 4), and "IMPORTANT NOTES" (p. 7). These sections provide important information concerning the proper operation of the unit. Additionally, in order to feel assured that you have gained a good grasp of every feature provided by your new unit, Owner's manual should be read in its entirety. The manual should be saved and kept on hand as a convenient reference.

Copyright © 2009 ROLAND CORPORATION

All rights reserved. No part of this publication may be reproduced in any form without the written permission of ROLAND CORPORATION.



USING THE UNIT SAFELY

INSTRUCTIONS FOR THE PREVENTION OF FIRE, ELECTRIC SHOCK, OR INJURY TO PERSONS

About ⚠ WARNING and ⚠ CAUTION Notices

⚠ WARNING	Used for instructions intended to alert the user to the risk of death or severe injury should the unit be used improperly.
⚠ CAUTION	Used for instructions intended to alert the user to the risk of injury or material damage should the unit be used improperly. * Material damage refers to damage or other adverse effects caused with respect to the home and all its furnishings, as well to domestic animals or pets.

About the Symbols

	The ⚠ symbol alerts the user to important instructions or warnings. The specific meaning of the symbol is determined by the design contained within the triangle. In the case of the symbol at left, it is used for general cautions, warnings, or alerts to danger.
	The ⚠ symbol alerts the user to items that must never be carried out (are forbidden). The specific thing that must not be done is indicated by the design contained within the circle. In the case of the symbol at left, it means that the unit must never be disassembled.
	The ⚠ symbol alerts the user to things that must be carried out. The specific thing that must be done is indicated by the design contained within the circle. In the case of the symbol at left, it means that the power-cord plug must be unplugged from the outlet.

ALWAYS OBSERVE THE FOLLOWING

⚠ WARNING

Safety grounding connection

Connect mains plug of this model to a mains socket outlet with a protective earthing connection.



Do not disassemble or modify

Do not open or perform any internal modifications on the unit.



Do not repair or replace parts

Do not attempt to repair the unit, or replace parts within it (except when this manual provides specific instructions directing you to do so). Refer all servicing to your retailer, the nearest Roland Service Center, or an authorized Roland distributor, as listed on the "Information" page.



Never install the unit in any of the following locations.

- Subject to temperature extremes (e.g., direct sunlight in an enclosed vehicle, near a heating duct, on top of heat-generating equipment); or are
- Damp (e.g., baths, washrooms, on wet floors); or are
- Exposed to steam or smoke; or are
- Subject to salt exposure; or are
- Humid; or are
- Exposed to rain; or are
- Dusty or sandy; or are
- Subject to high levels of vibration and shakiness.



⚠ WARNING

Use only a stand that is recommended

This unit should be used only with a stand that is recommended by Roland.



Do not place in an unstable location

When using the unit with a rack or stand recommended by Roland, the rack or stand must be carefully placed so it is level and sure to remain stable. If not using a rack or stand, you still need to make sure that any location you choose for placing the unit provides a level surface that will properly support the unit, and keep it from wobbling.



Connect the power cord to an outlet of the correct voltage

The unit should be connected to a power supply only of the type described in the operating instructions, or as marked on the rear side of unit.



Use only the included power cord

Use only the attached power-supply cord. Also, the supplied power cord must not be used with any other device.



Do not bend the power cord or place heavy objects on it

Do not excessively twist or bend the power cord, nor place heavy objects on it. Doing so can damage the cord, producing severed elements and short circuits. Damaged cords are fire and shock hazards!



⚠ WARNING

Avoid extended use at high volume

This unit, either alone or in combination with an amplifier and headphones or speakers, may be capable of producing sound levels that could cause permanent hearing loss. Do not operate for a long period of time at a high volume level, or at a level that is uncomfortable. If you experience any hearing loss or ringing in the ears, you should immediately stop using the unit, and consult an audiologist.



Do not insert foreign objects

Do not allow any objects (e.g., flammable material, coins, pins); or liquids of any kind (water, soft drinks, etc.) to penetrate the unit.



Turn off the power if an abnormality or malfunction occurs

Immediately turn the power off, remove the power cord from the outlet, and request servicing by your retailer, the nearest Roland Service Center, or an authorized Roland distributor, as listed on the "Information" page when:

- The power-supply cord or the plug has been damaged; or
- If smoke or unusual odor occurs
- Objects have fallen into, or liquid has been spilled onto the unit; or
- The unit has been exposed to rain (or otherwise has become wet); or
- The unit does not appear to operate normally or exhibits a marked change in performance.



Do not allow children to use without supervision

In households with small children, an adult should provide supervision until the child is capable of following all the rules essential for the safe operation of the unit.



Do not drop or subject to strong impact

Protect the unit from strong impact. (Do not drop it!)



⚠ WARNING

Do not share an outlet with an unreasonable number of other devices

Do not force the unit's power-supply cord to share an outlet with an unreasonable number of other devices. Be especially careful when using extension cords—the total power used by all devices you have connected to the extension cord's outlet must never exceed the power rating (watts/amperes) for the extension cord. Excessive loads can cause the insulation on the cord to heat up and eventually melt through.



Do not use overseas

Before using the unit in a foreign country, consult with your retailer, the nearest Roland Service Center, or an authorized Roland distributor, as listed on the "Information" page.



Do not use a CD-ROM in an audio CD player or DVD player

DO NOT play a CD-ROM disc on a conventional audio CD player or DVD player. The resulting sound may be of a level that could cause permanent hearing loss. Damage to speakers or other system components may result.



Do not place containers of water on the device

Do not put anything that contains water (e.g., flower vases) on this unit. Also, avoid the use of insecticides, perfumes, alcohol, nail polish, spray cans, etc., near the unit. Swiftly wipe away any liquid that spills on the unit using a dry, soft cloth.



⚠ CAUTION

Place in a well ventilated location

The unit should be located so that its location or position does not interfere with its proper ventilation.



Use only the specified stands

This (V-Piano) for use only with Roland stand KS-V8 or KS-G8. Use with other stands is capable of resulting in instability causing possible injury.



Check the safety of the stand before use

Please be sure to read and adhere to the cautionary notices contained in the instructions that came with this product. Please note that, depending on the manner in which keyboard performances are carried out, you may encounter situations where the keyboard falls off the stand or the stand topples over, even though you have followed all of the instructions and advice contained within the product's manual. For this reason, you should always perform a safety check each time you use the stand.



Grasp the plug when connecting or disconnecting the power cord

Always grasp only the plug on the power-supply cord when plugging into, or unplugging from, an outlet or this unit.



Periodically wipe the dust off the power cord plug

At regular intervals, you should unplug the power plug and clean it by using a dry cloth to wipe all dust and other accumulations away from its prongs. Also, disconnect the power plug from the power outlet whenever the unit is to remain unused for an extended period of time. Any accumulation of dust between the power plug and the power outlet can result in poor insulation and lead to fire.



Manage cables for safety

Try to prevent cords and cables from becoming entangled. Also, all cords and cables should be placed so they are out of the reach of children.



Do not stand or place heavy objects on this device

Never climb on top of, nor place heavy objects on the unit.



⚠ CAUTION

Do not connect or disconnect the power cord with wet hands

Never handle the power cord or its plugs with wet hands when plugging into, or unplugging from, an outlet or this unit.



Remove cords and cables before moving the unit

Before moving the unit, disconnect the power plug from the outlet, and pull out all cords from external devices.



Cautions when moving this device

If you need to move the instrument, take note of the precautions listed below. At least two persons are required to safely lift and move the unit. It should be handled carefully, all the while keeping it level. Make sure to have a firm grip, to protect yourself from injury and the instrument from damage.



- Disconnect the power cord.
- Disconnect all cords coming from external devices.
- If you're using the stand (KS-V8), remove the headphone hook from the unit.
- If you're using the stand (KS-V8), remove the unit from the stand and transport them dividing of each.

Unplug the power cord from the AC outlet before cleaning

Before cleaning the unit, turn off the power and unplug the power cord from the outlet (p. 17).



If there is a possibility of lightning strike, disconnect the power cord from the AC outlet

Whenever you suspect the possibility of lightning in your area, pull the plug on the power cord out of the outlet.



IMPORTANT NOTES

Power Supply

- Do not connect this unit to same electrical outlet that is being used by an electrical appliance that is controlled by an inverter (such as a refrigerator, washing machine, microwave oven, or air conditioner), or that contains a motor. Depending on the way in which the electrical appliance is used, power supply noise may cause this unit to malfunction or may produce audible noise. If it is not practical to use a separate electrical outlet, connect a power supply noise filter between this unit and the electrical outlet.
- Before connecting this unit to other devices, turn off the power to all units. This will help prevent malfunctions and/or damage to speakers or other devices.
- Although the LCD and LEDs are switched off when the POWER switch is switched off, this does not mean that the unit has been completely disconnected from the source of power. If you need to turn off the power completely, first turn off the POWER switch, then unplug the power cord from the power outlet. For this reason, the outlet into which you choose to connect the power cord's plug should be one that is within easy reach and readily accessible.

Placement

- Using the unit near power amplifiers (or other equipment containing large power transformers) may induce hum. To alleviate the problem, change the orientation of this unit; or move it farther away from the source of interference.
- This device may interfere with radio and television reception. Do not use this device in the vicinity of such receivers.
- Noise may be produced if wireless communications devices, such as cell phones, are operated in the vicinity of this unit. Such noise could occur when receiving or initiating a call, or while conversing. Should you experience such problems, you should relocate such wireless devices so they are at a greater distance from this unit, or switch them off.
- Do not expose the unit to direct sunlight, place it near devices that radiate heat, leave it inside an enclosed vehicle, or otherwise subject it to temperature extremes. Also, do not allow lighting devices that normally are used while their light source is very close to the unit (such as a piano light), or powerful spotlights to shine upon the same area of the unit for extended periods of time. Excessive heat can deform or discolor the unit.
- When moved from one location to another where the temperature and/or humidity is very different, water droplets (condensation) may form inside the unit. Damage or malfunction may result if you attempt to use the unit in this condition. Therefore, before using the unit, you must allow it to stand for several hours, until the condensation has completely evaporated.
- Do not allow rubber, vinyl, or similar materials to remain on the unit for long periods of time. Such objects can discolor or otherwise harmfully affect the finish.
- Do not allow objects to remain on top of the keyboard. This can be the cause of malfunction, such as keys ceasing to produce sound.
- Do not paste stickers, decals, or the like to this instrument. Peeling such matter off the instrument may damage the exterior finish.
- Depending on the material and temperature of the surface on which you place the unit, its rubber feet may discolor or mar the surface. You can place a piece of felt or cloth under the rubber feet to prevent this from happening. If you do so, please make sure that the unit will not slip or move accidentally.

Maintenance

- To clean the unit, use a dry, soft cloth; or one that is slightly dampened. Try to wipe the entire surface using an equal amount of strength. Rubbing too hard in the same area can damage the finish.
- Never use benzene, thinners, alcohol or solvents of any kind, to avoid the possibility of discoloration and/or deformation.

Repairs and Data

- Please be aware that all data contained in the unit's memory may be lost when the unit is sent for repairs. Important data should always be backed up on a USB memory, or written down on paper (when possible). During repairs, due care is taken to avoid the loss of data. However, in certain cases (such as when circuitry related to memory itself is out of order), we regret that it may not be possible to restore the data, and Roland assumes no liability concerning such loss of data.

USB Memory Handling

(Using USB Memory)

- When connecting USB memory, firmly insert it all the way in.
- Do not touch the pins of the USB memory connector, or allow them to become dirty.
- USB memory is made using high-precision electronic components, so please observe the following points when handling it.
 - To prevent damage from static electrical charges, discharge any static electricity that might be present in your body before handling USB memory.
 - Do not touch the terminals with your fingers or any metal object.
 - Do not bend or drop USB memory, or subject it to strong impact.
 - Do not leave USB memory in direct sunlight or in locations such as a closed-up automobile. (Storage temperature: 0–50 degrees C)
 - Do not allow USB memory to become wet.
 - Do not disassemble or modify USB memory.
- When connecting USB memory, position it horizontally with the USB MEMORY connector and insert it without using excessive force. The USB MEMORY connector may be damaged if you use excessive force when inserting USB memory.
- Do not insert anything other than USB memory (e.g., wire, coins, other types of device) into the USB MEMORY connector. Doing so will damage the USB MEMORY connector.
- Do not apply excessive force to the connected USB memory.
- If you will not be using USB memory for an extended period of time, close the USB memory cover.

CD Handling

- When handling the discs, please observe the following.
 - Do not touch the encoded surface of the disc.
 - Do not use in dusty areas.
 - Do not leave the disc in direct sunlight or an enclosed vehicle.
- Do not touch or scratch the recording surface of a CD. Doing so may render the data unreadable. If a CD becomes soiled, clean it using a commercially available CD cleaner.
- Keep the disc in the case.
- Do not keep the disc in the CD drive for a long time.
- Do not put a sticker on the label of the disc.
- If dust or dirt adheres to a CD, lightly wipe it off with a soft cloth. Always wipe from the center toward the outer edge of the disc. Do not wipe in a concentric circular direction.
- Do not use benzine, record cleaner spray or solvents of any kind.
- Do not bend the disc. Bending discs may prevent proper reading and writing of data, and may further result in malfunction.

Additional Precautions

- Please be aware that the contents of memory can be irretrievably lost as a result of a malfunction, or the improper operation of the unit. To protect yourself against the risk of losing important data, we recommend that you periodically save a backup copy of important data you have stored in the unit's memory on a USB memory.
- Unfortunately, it may be impossible to restore the contents of data that was stored in the unit's internal memory, or on a USB memory once it has been lost. Roland Corporation assumes no liability concerning such loss of data.
- Use a reasonable amount of care when using the unit's buttons, sliders, or other controls; and when using its jacks and connectors. Rough handling can lead to malfunctions.
- Never strike or apply strong pressure to the display.
- When connecting / disconnecting all cables, grasp the connector itself—never pull on the cable. This way you will avoid causing shorts, or damage to the cable's internal elements.
- A small amount of heat will radiate from the unit during normal operation.
- To avoid disturbing your neighbors, try to keep the unit's volume at reasonable levels (especially when it is late at night).
- When you need to transport the unit, package it in the box (including padding) that it came in, if possible. Otherwise, you will need to use equivalent packaging materials.
- Use only the specified expression pedal (EV-5/EV-7; sold separately). By connecting any other expression pedals, you risk causing malfunction and/or damage to the unit.
- Some connection cables contain resistors. Do not use cables that incorporate resistors for connecting to this unit. The use of such cables can cause the sound level to be extremely low, or impossible to hear. For information on cable specifications, contact the manufacturer of the cable.
- If you update unit's internal program via USB FOR UPDATE terminal, disconnect all cords except power cord before updating.

- GS () is a registered trademark of Roland Corporation.
- All product names mentioned in this document are trademarks or registered trademarks of their respective owners.
- MPEG Layer-3 audio compression technology is licensed from Fraunhofer IIS Corporation and THOMSON Multimedia Corporation.
- MMP (Moore Microprocessor Portfolio) refers to a patent portfolio concerned with microprocessor architecture, which was developed by Technology Properties Limited (TPL). Roland has licensed this technology from the TPL Group.

Contents

USING THE UNIT SAFELY	4
IMPORTANT NOTES	7
Panel descriptions	12
Front panel	12
Bottom panel	13
Rear panel	14
Getting ready	15
Placing the V-Piano on a stand	15
Connecting the power cord	17
Connecting external equipment to the V-Piano	18
Connecting the piano pedal	20
Connecting headphones	21
Connecting multi-channel speakers	21
Turning the power on and off	22
Turning on the power	22
Turning off the power	23
Adjusting the volume	23
Adjusting the display's contrast ([DISPLAY CONTRAST] Knob)	23
Using the USB memory	24
Connecting the USB memory	24
Connecting a CD drive	25
Attaching the CD drive (CD-01A)	25
Introducing the V-Piano	27
How the V-Piano is structured	27
The V-Piano's parameters	27
Backing up and initializing	28
How the V-Piano's screens are organized	29
Tone screen	29
Song screen	31
Utility screen	31
Listening to the demo songs	32

Playing	34
Selecting and playing a sound	34
Adjusting the tonal character (Equalizer)	37
Saving the equalizer settings	38
Adding reverberation to the sound (Ambience)	39
Switching the ambience type	39
Saving the ambience settings	40
Shifting the pitch (Transpose).....	41
Disabling the buttons (Panel Lock)	42
Assigning functions to the [F1]–[F3] buttons.....	43
Using the pedals to control the V-Piano’s functions	45
Functions that can be assigned to a pedal	45
Assigning a function to a pedal	46
Customizing the V-Piano’s sounds.....	48
The V-Piano’s parameters.....	48
Editing a parameter’s value	50
Saving a tone you’ve customized	51
Changing the parameters shown in the tone screen.....	53
Editing the stretch tune	54
Editing individual keys.....	55
Specifying the key range (RangeSet).....	55
Velocity Follow settings	57
Unison Tune parameters.....	57
Viewing the original tone	58
About V-Piano Editor.....	58
Saving your settings (Setups)	59
Recalling a setup	59
Creating a setup.....	60
Assigning a name to a setup and saving it.....	60
Assigning favorite setups to the buttons	62
Recalling a setup you assigned to a button	63
Playing songs and recording your performances	64
About the song screen	64
[F1]–[F4] button operations.....	65
Playing a song.....	66
Recording your performance.....	70
Saving your recorded performance.....	73
Option settings in the song screen	74
Types of audio data that the V-Piano can play	75

Detailed settings for various functions (Utility screen)..... 76

How to make settings	76
Saving the System parameters	77
Parameters That Can Be Set	78
System settings (1. System)	80
Tone parameter settings (2. Tone Parameter)	82
Keyboard touch settings (3. Key Touch).....	83
Pedal settings (4. Pedal)	84
Functions that can be assigned to a pedal	85
MIDI settings (5. MIDI).....	86
Ambience settings (6. Ambience)	86
File management (7. File)	87
Saving a setup file (Save SETUP File).....	87
Loading a setup file (Load SETUP File)	89
Deleting a setup file (Delete SETUP File)	90
Copying a setup file (Copy SETUP File)	91
Saving a song (Save SONG File).....	92
Deleting a song (Delete SONG File)	93
Copying a song (Copy SONG File)	94
Formatting internal memory or USB memory (Format)	95
V-LINK settings (8. V-LINK).....	96
Connection Examples	96
Turning the V-LINK ON/OFF	96
V-LINK function chart	97
V-LINK Settings	97
Restoring the factory settings (9. Initialize).....	98
Deleting the user tones (Delete User Tone)	98
Factory reset (Factory Reset All)	99
Playing or recording a song (10. Song).....	100
Saving a setup (11. Setup Write)	101

Troubleshooting 102

Error Messages..... 104

List of shortcuts..... 105

MIDI Implementation Chart..... 106

Specifications 107

Index 109

Convention Used in This Manual

- Text enclosed in square brackets [] indicates the name of a button, such as the [ENTER] button.
- Lines that begin with **NOTE** or an asterisk * are cautionary statements that you must be sure to read.
- (p. **) indicates a reference page.
- The explanations in this manual include illustrations that depict what should typically be shown by the display. Note, however, that your unit may incorporate a newer, enhanced version of the system (e.g., includes newer sounds), so what you actually see in the display may not always match what appears in the manual.

Panel descriptions

Front panel

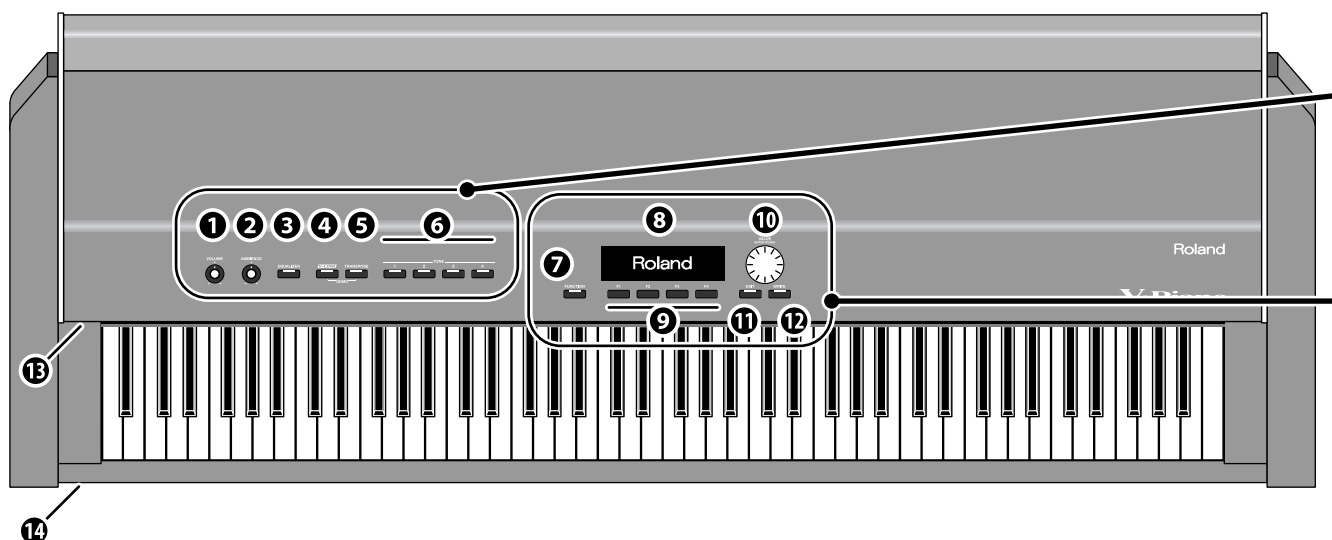

1. [VOLUME] Knob

Adjusts the volume that is output from the rear panel OUTPUT jacks and headphone jack (p.23).

2. [AMBIENCE] Knob

Adjusts the amount of ambience effect, which adds acoustic resonance to the sound (p.39).

3. [EQUALIZER] Button

Turns the equalizer on/off (p.37).

The [EQUALIZER] button will light when the equalizer is on.

4. [V-LINK] Button

Turns the V-LINK function on/off.

When this is on, the [V-LINK] button will light, allowing a V-LINK compatible video device connected to the V-Piano to be controlled from the V-Piano (p.96).

5. [TRANSPOSE] Button

Transposes the pitch (p.41).

The [TRANSPOSE] button will light when transpose is turned on.

By pressing this button simultaneously with the [V-LINK] button, you can play demo songs (p.32).

6. TONE Buttons: [TONE 1]–[TONE 4]

Use these buttons to select tones.

MEMO

Alternatively, you can change the System settings so that these buttons will select setups (p.62).

7. [FUNCTION] Button

This switches the function of function buttons [F1]–[F4].

The [FUNCTION] button will light when the function is on.

8. Display

This shows information such as the tone name, setup name, or the item you're editing.

NOTE

The explanations in this manual include illustrations that depict what should typically be shown by the display. Note, however, that your unit may incorporate a newer, enhanced version of the system (e.g., includes newer sounds), so what you actually see in the display may not always match what appears in the manual.

9. [F1]–[F4] Buttons

When editing, you'll use these buttons to execute a variety of functions; their operation will differ depending on the screen.

10. [VALUE] Dial ([ENTER] Button)

Use this to modify values.

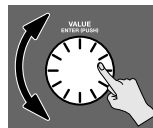

By pressing the VALUE dial, you can finalize a value or execute an operation ([ENTER] button).

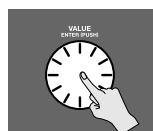

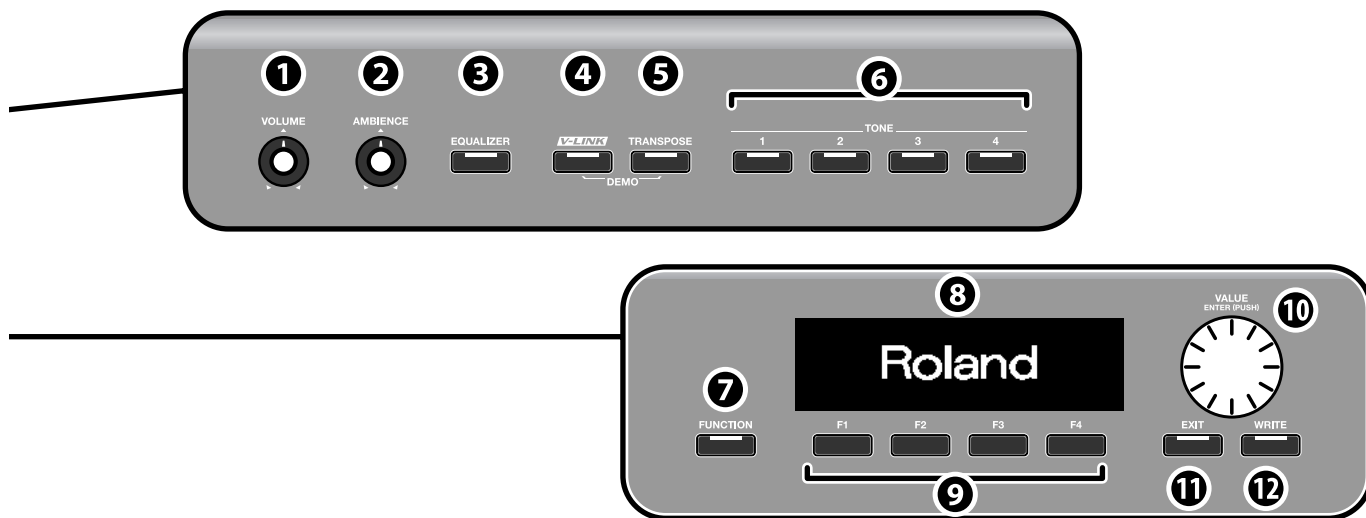

Bottom panel

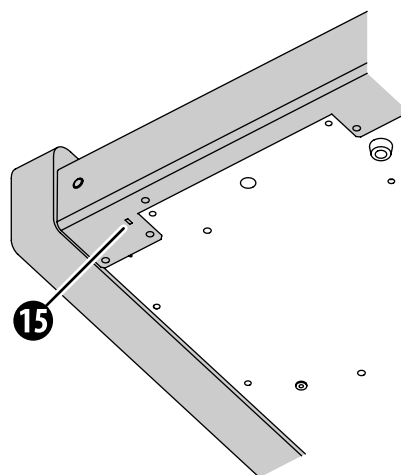
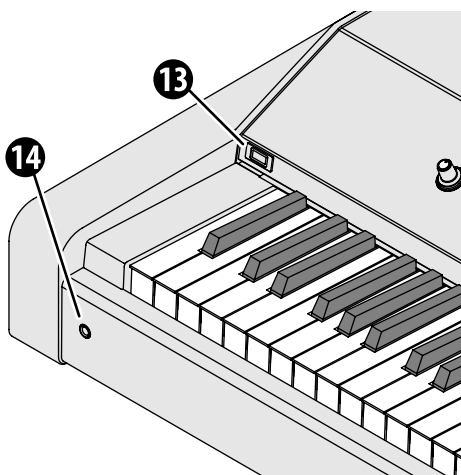

11. [EXIT] Button

Returns you to the previous screen or cancels the function that was being executed.

12. [WRITE] Button

Saves a customized tone as a User tone (p.51).

13. USB Memory Connector

Connect separately sold USB memory or a CD drive here (p.24).

14. Headphone Jack

Connect headphones here (p.21).

Even when headphones are connected, sound will still be output from the OUTPUT jacks and the DIGITAL OUT jack.

15. Security Slot

<http://www.kensington.com/>

Rear panel

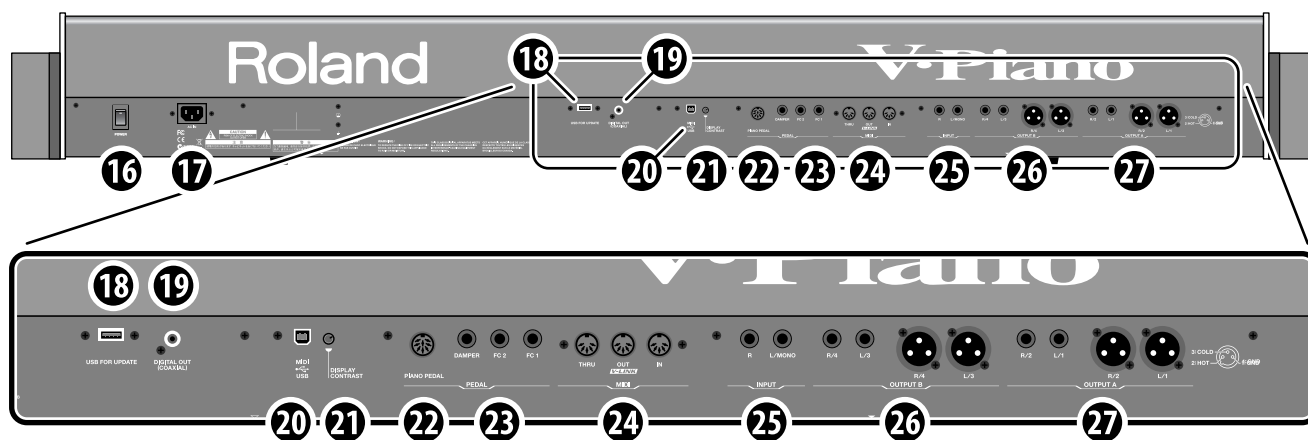

16. [POWER] Switch

Turns the power on/off (p.22).

17. AC Inlet

Connect the included power cord here (p.17).

18. USB FOR UPDATE Connector

This is used when updating the V-Piano's internal operating program.

NOTE

Do not connect anything to this connector during normal use.

19. DIGITAL OUT (COAXIAL) Connector

This is a coaxial type digital output jack. This will digitally output the same audio as is output from the OUTPUT A jacks.

It complies with the S/PDIF format, and outputs a digital audio signal (stereo).

- * The [VOLUME] Knob will not adjust the volume of this connector. Use the controls of your input device to adjust the volume.
- * S/PDIF is a digital interface format that is used by consumer digital audio equipment.

20. USB MIDI Connector

When you want to use the included editor, use a USB cable to connect this connector to your computer (p.58).

21. [DISPLAY CONTRAST] Knob

Adjusts the contrast of the display (p.23).

22. PIANO PEDAL Connector

Connect the included piano pedal here (p.20).

23. DAMPER Connector / FC1 Connector / FC2 Connector

Connect separately sold pedals or switches here.

A variety of functions can be assigned to pedals connected to the FC1 connector and FC2 connector (p.84).

24. MIDI Connectors: IN, OUT/V-LINK, THRU

Connect these to external MIDI devices to transmit or receive MIDI messages.

25. INPUT Jacks: L/MONO, R

These are audio signal input jacks. You can connect an external audio playback device here, and output its sound mixed with the sound of the V-Piano.

- * You cannot adjust the input level of these jacks, nor the balance between these inputs and the V-Piano's output.

26. OUTPUT B Connectors: L/3, R/4

These are audio signal output jacks. The signal to be output from these jacks can be selected from a menu (p.81).

You can use these jacks in conjunction with the OUTPUT A jacks to output the V-Piano's sound as four-channel output.

The phone jack and XLR connectors output the same signal.

27. OUTPUT A Connectors: L/1, R/2

These are the main audio signal output jacks.

The phone jacks and XLR connectors output the same signal.

About the XLR OUTPUT connectors

This instrument is equipped with balanced (XLR) type jacks. These jacks are wired as shown below. Make connections after first checking the wiring diagrams of other equipment you intend to connect.



About the phone (1/4") OUTPUT connectors

If you connect a phone plug to only the L/1 (and L/3) phone jacks, they will output a mono signal that mixes-in the R/2 (and R/4) signals, allowing you to use these as mono outputs.

- * The XLR connectors will output a stereo signal.
- * The V-Piano is designed to be used with stereo output. The sound quality and tonal character will be affected if you use monaural output.

Getting ready

Placing the V-Piano on a stand

If you place the V-Piano on a stand, you must use the KS-V8 or KS-G8 (sold separately).

NOTE

- When placing the V-Piano on the stand, be careful not to pinch your fingers between the instrument and the stand.
- You must use two or more people to lift the V-Piano onto the stand.
- Using the V-Piano with any other stand may produce an unstable situation, possibly causing the instrument to fall or overturn, and resulting in injury or damage.
- For details on how to assemble the stand, refer to the owner's manual that accompanied the stand.

If using the KS-V8 stand

1. Place the V-Piano so it's positioned as shown in the illustration.

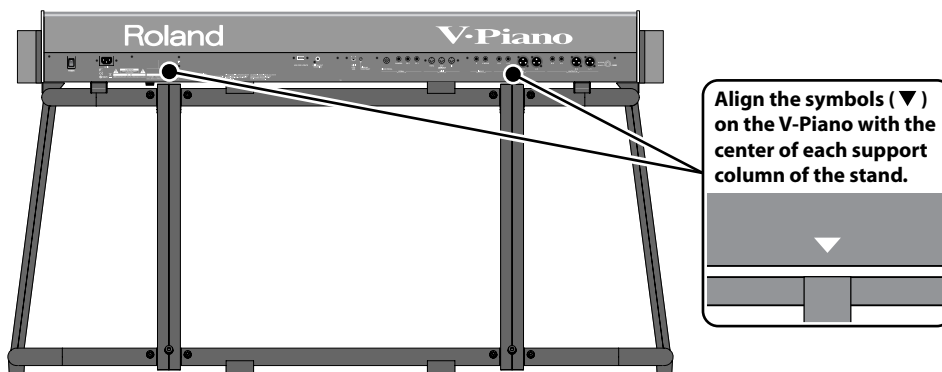

2. Using the knob bolts included with the KS-V8, fasten the V-Piano to the stand (four locations).

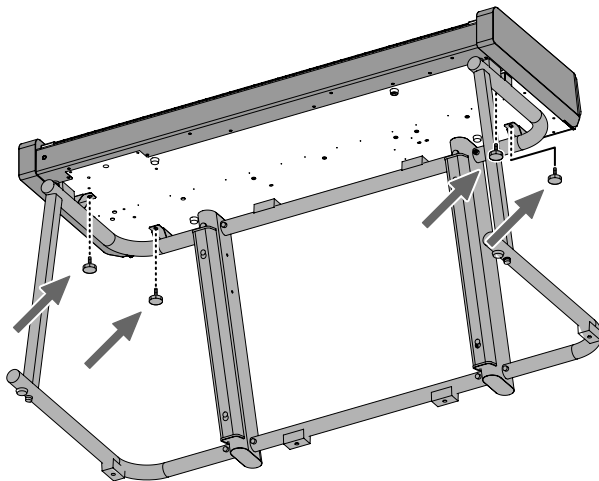

3. Connect the piano pedals to the PIANO PEDAL connector located on the rear panel of the instrument.

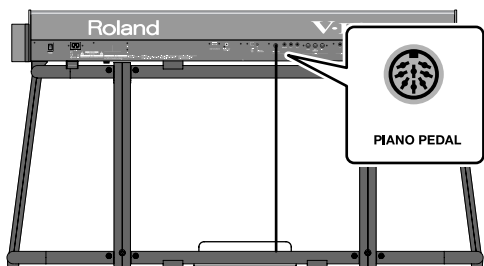

4. Attach the headphone hook included with the KS-V8.

Insert the headphone hook into the hole located on the bottom of the instrument toward the left side, and fasten it by tightening the wing nut.

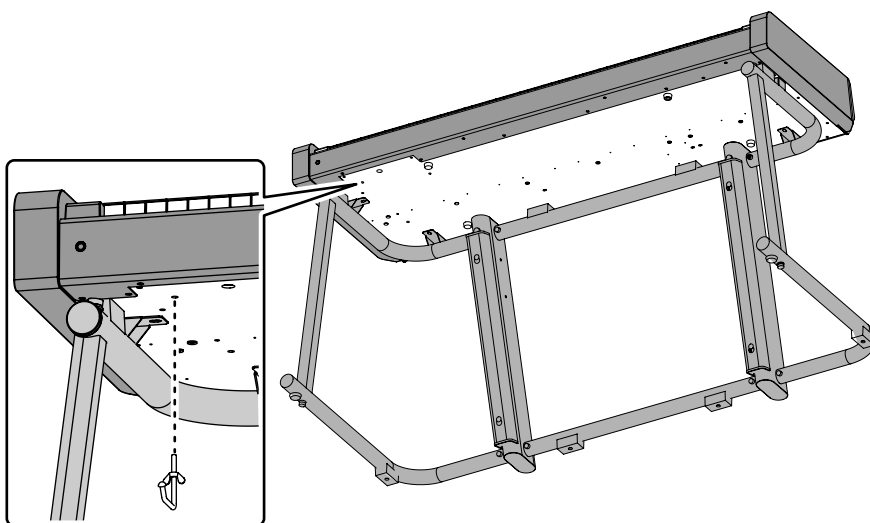

NOTE

Only headphones should be placed on the headphone hook. If you use it to hold other objects, you risk damaging the instrument or the headphone hook.

NOTE

If you need to remove the instrument from the stand, detach the headphone hook first.

5. Secure the piano pedal cable, power cord, and other connection cables inside the stand's cable covers.

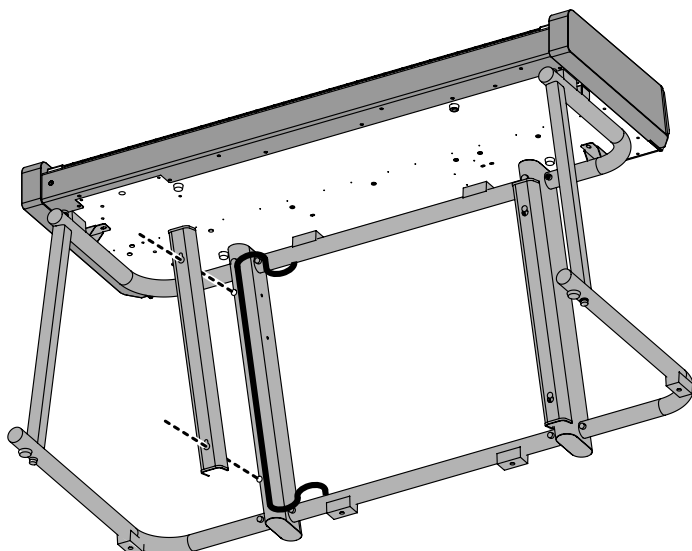

If using the KS-G8 stand

1. Place the V-Piano in the position shown in the illustration.

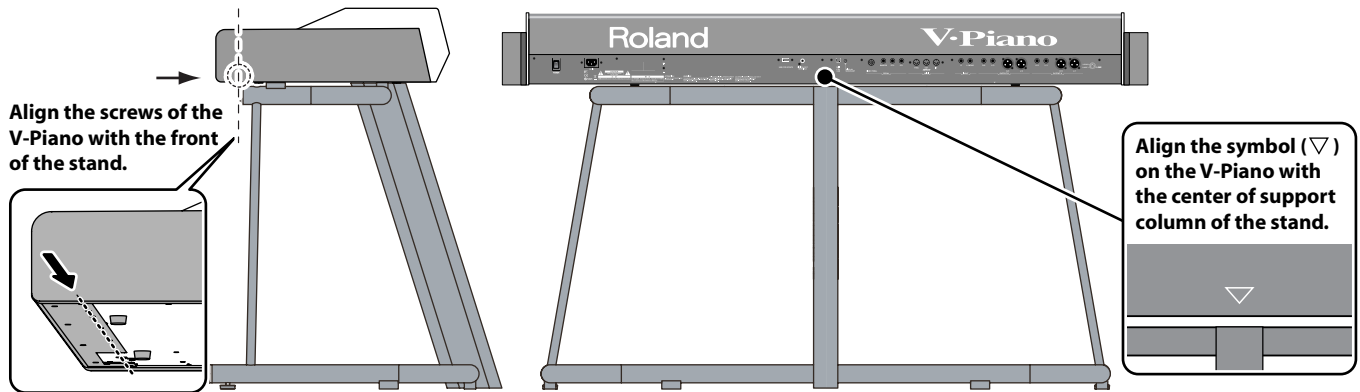

Connecting the power cord

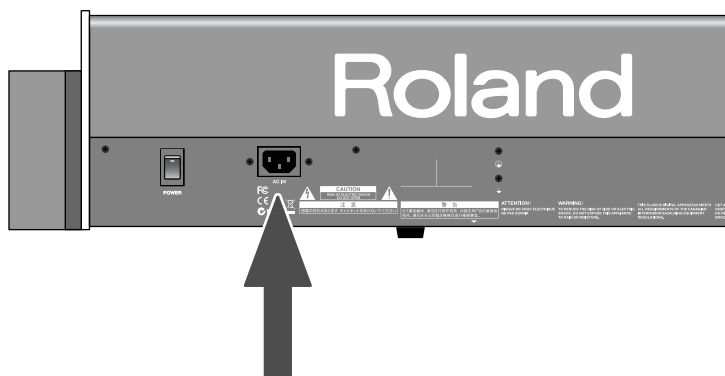

1. **Before you begin making connections, confirm the following.**
 - Is the volume level of the V-Piano or connected amp turned all the way down?
 - Is the power to the V-Piano or connected amp turned off?
2. **Connect the supplied power cord to the AC Inlet of the V-Piano, and plug the other end into an AC outlet.**

Connecting external equipment to the V-Piano

The V-Piano is not equipped with an amplifier or speakers. In order to produce sound, you need to hook up audio equipment such as a monitor speaker or a stereo set, or use headphones.

* Audio cables, MIDI cables, headphones, and expression pedals are not included. Consult your Roland dealer if you need to purchase accessories such as these.

NOTE

To prevent malfunction and/or damage to speakers or other devices, always turn down the volume, and turn off the power on all devices before making any connections.

NOTE

When connection cables with resistors are used, the volume level of equipment connected to the INPUT jacks may be low. If this happens, use connection cables that do not contain resistors.

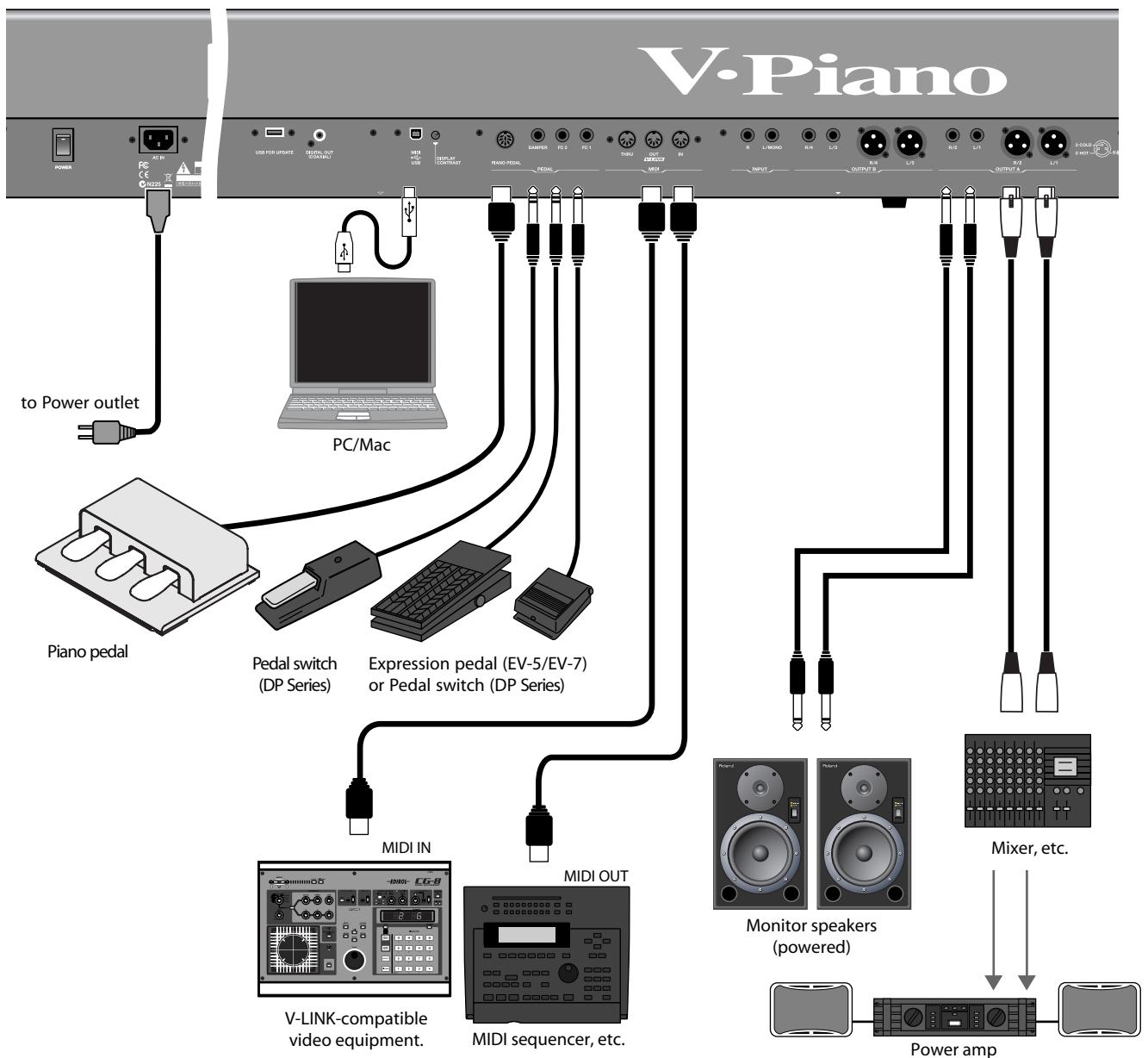

1. Before you begin making connections, confirm the following.

- Is the volume level of the V-Piano or connected amp turned all the way down?
- Is the power to the V-Piano or connected amp turned off?

2. Connect the supplied power cord to the AC Inlet of the V-Piano, and plug the other end into an AC outlet.**3. Connect the V-Piano and the external devices.**

Use audio cables to connect audio equipment, such as an amp or speakers.

Use MIDI cables to connect MIDI devices. Use USB cables to connect to a computer.

If you are using headphones, plug them into the headphone jack.

Connect pedal switches or expression pedals as necessary.

NOTE

Use Stereo headphones.

NOTE

Use only a specified expression pedal (EV-5/EV-7; sold separately). By connecting any other expression pedal, you risk causing malfunction and/or damage to the unit.

MEMO

You can connect a commercially available CD drive to the USB MEMORY connector. You can use a CD drive to play back songs from a CD.

About the XLR OUTPUT connectors

This instrument is equipped with balanced (XLR) type jacks. A wiring diagram for these jacks is shown below. Make connections after first checking the wiring diagrams of other equipment you intend to connect.

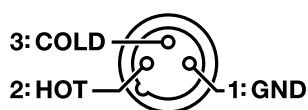
**About the phone (1/4") OUTPUT connectors**

If you connect a phone plug to only the L/1 (and L/3) phone connectors, they will output a mono signal that mixes-in the R/2 (and R/4) signals, allowing you to use these as mono outputs.

- * The XLR connectors will output a stereo signal.
- * The V-Piano is designed to be used with stereo output. The sound quality and tonal character will be affected if you use monaural output.

Connecting the piano pedal

Connect the cable of the included piano pedal to the PIANO PEDAL connector on the V-Piano's rear panel.

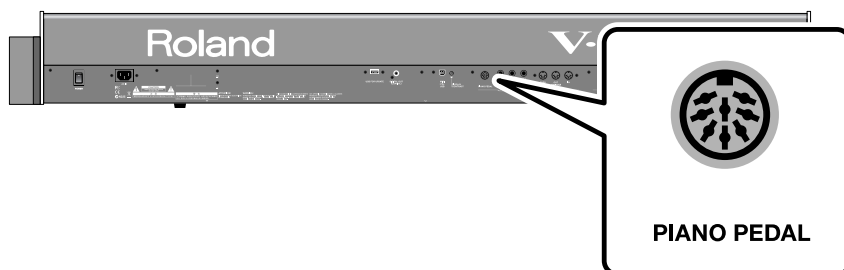

About the pedals

The pedals perform the following operations. You'll use them mainly for playing piano.

MEMO

By changing the pedal assignments, you can change what the V-Piano does when you press the sostenuto pedal or soft pedal. For details, refer to "Pedal settings (4. Pedal)" (p. 84).

Damper Pedal (right pedal)

While this pedal is held down, notes will be sustained for an extended time even if you release your fingers from the keyboard.

The length of the sustain will change subtly depending on how deeply you press the pedal.

On an acoustic piano, holding down the damper pedal will cause the strings for notes other than the ones you actually play to vibrate in sympathy with what you've played, producing a rich resonance. The V-Piano simulates this sympathetic vibration (damper resonance).

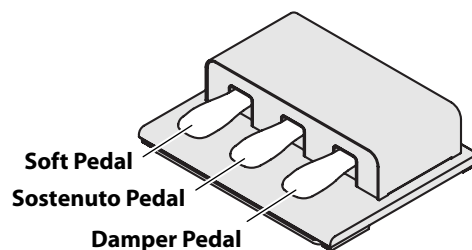

Sostenuto Pedal (center pedal)

The notes you are pressing when this pedal is depressed will be sustained.

Soft Pedal (left pedal)

If you hold down this pedal, the notes will be softer in tone.

The softness of the tone can be varied subtly by changing the depth to which you press the pedal (p. 48).

You can adjust the sensitivity of the soft pedal (p. 48).

Connecting headphones

1. Plug the headphones into the headphone jack.

NOTE

Use stereo headphones.

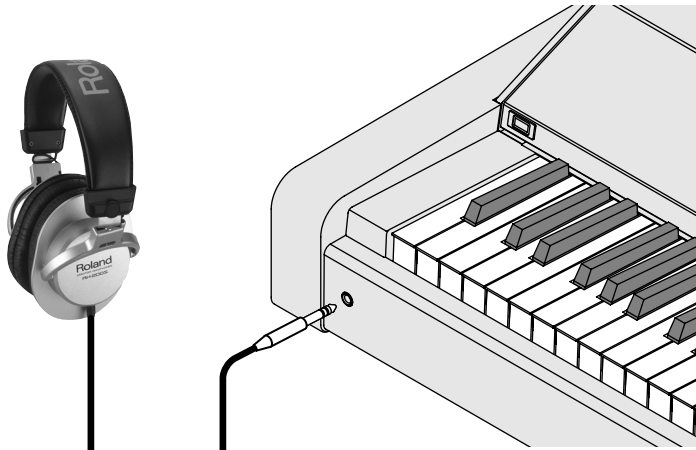

Connecting multi-channel speakers

If you've set the system parameter Sound Perspective (p. 81) to "A:DRY B:AMBIENCE" or "GRAND AMBIENCE" for multi-channel output, you should place your speakers in the areas shown in the diagram below.

MEMO

Place the OUTPUT A speakers near the performer, and place the OUTPUT B speakers farther away.

MEMO

The volume balance, spacing of the OUTPUT B speakers, direction, and distance to the speakers can be adjusted according to your taste.

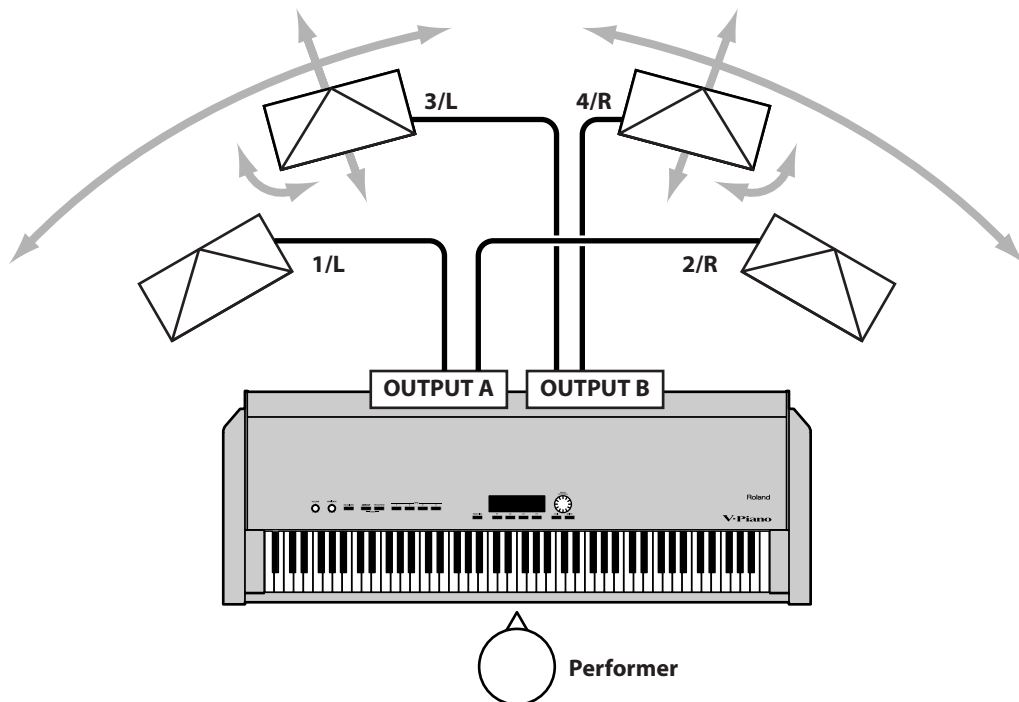

Turning the power on and off

NOTE

Once the connections have been completed (p. 18), turn on power to your various devices in the order specified. By turning on devices in the wrong order, you risk causing malfunction and/or damage to speakers and other devices.

Turning on the power

1. **Before you turn on the power, use the [VOLUME] Knob to minimize the volume.**

Also, completely turn down the volume of any connected audio device and other equipment.

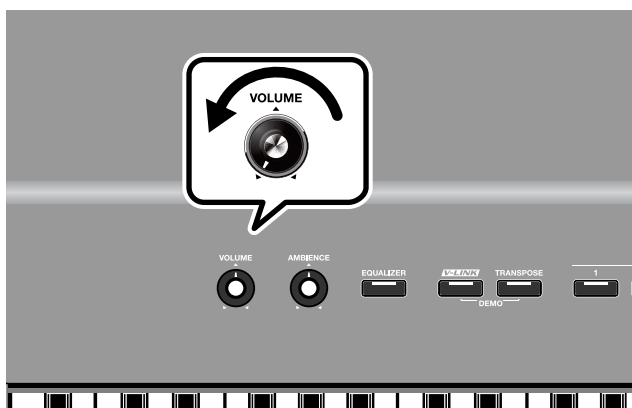

2. **Press the upper portion of the [POWER] switch on the back of the V-Piano to turn on the power.**

The unit is powered up, and the display's backlighting comes on.

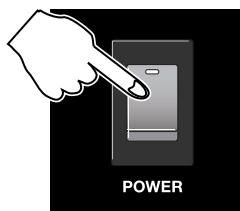

NOTE

Always make sure to have the volume level turned down before switching on power. Even with the volume all the way down, you may still hear some sound when the power is switched on, but this is normal, and does not indicate a malfunction.

NOTE

Due to a circuitry protection feature, this instrument requires a few moments after it has been turned on before it is ready for normal operation.

NOTE

In the unlikely event the power is turned off or cut off while Factory Reset (p. 99) is in progress, the data may become corrupted, and it may require additional time for the unit to start up the next time.

3. **Turn on the power to connected external devices.**
4. **Adjust the volume of the connected external devices.**
5. **Adjust the V-Piano's volume to obtain the proper volume level.**

Turning off the power

1. **Before you switch off the power, turn the volume down all the way with the [VOLUME] Knob.**

Also completely turn down the volume of any connected audio device and other equipment.

2. **Turn off the power to connected external devices.**

3. **Press the lower portion of the [POWER] switch on the back of the V-Piano.**

The power is switched off.

NOTE

If you need to turn off the power completely, first turn off the [POWER] switch, then unplug the power cord from the power outlet. Refer to "Power Supply" (p. 7).

Adjusting the volume

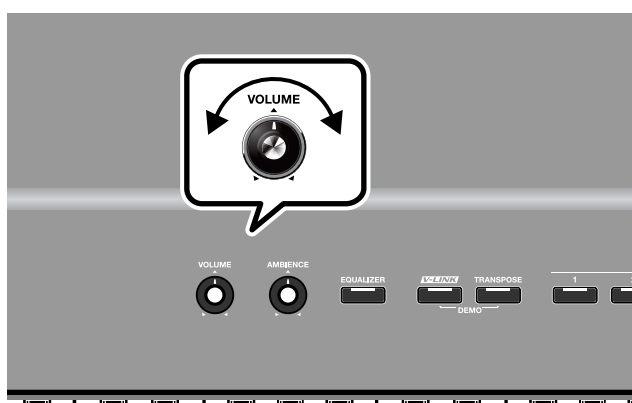

1. **Adjust the volume using the [VOLUME] Knob.**

Rotate the knob clockwise to increase the volume, or rotate it counterclockwise to lower it.

Also, adjust the volume of the connected device to an appropriate level.

Adjusting the display's contrast ([DISPLAY CONTRAST] Knob)

The characters in the display may be difficult to view immediately after turning on the power or after extended use; this may also be because of where and how the display is situated.

In such instances, adjust the contrast of the display by turning the [DISPLAY CONTRAST] Knob on the rear panel.

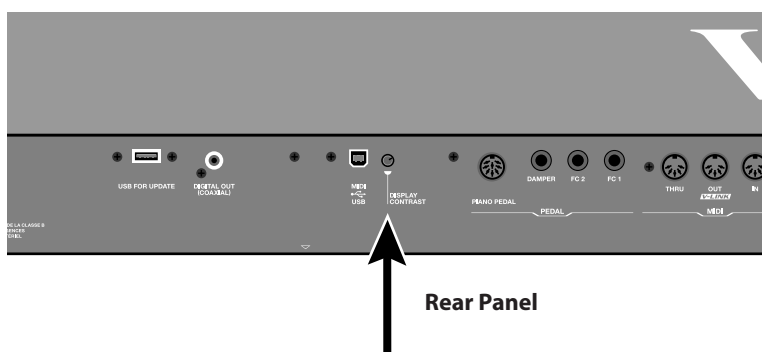

Rear Panel

Using the USB memory

You can copy Setup files (p. 87) and song files to separately sold USB memory for safekeeping.

You can also play back SMF music files that are saved on USB memory, or play audio files from USB memory (p. 64).

Connecting the USB memory

1. Connect your USB memory to the USB MEMORY connector located on the V-Piano's front panel.

Carefully insert the USB memory all the way in, until it is firmly in place.

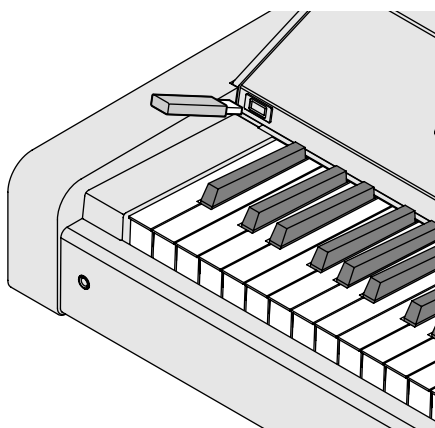

MEMO

If you're using new USB memory, you must first initialize (format) it on the V-Piano. For details, refer to "Formatting internal memory or USB memory (Format)" (p. 95).

Connecting a CD drive

You can connect a CD drive (CD-01A; sold separately) to the USB memory connector, and perform while playing back a music CD. You can also play back SMF music data saved on a CD-ROM (p. 64).

Attaching the CD drive (CD-01A)

If you're using the KS-V8 (a dedicated keyboard stand for the V-Piano), you can attach the CD-01A to the V-Piano's bottom panel.

1. Set the POWER switch of the CD drive (CD-01A) to "AUTO."

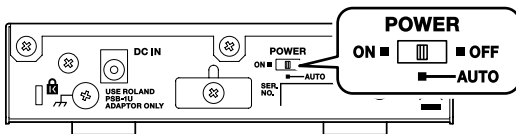

2. Use screws (3 x 8 mm) to attach the holder to the CD drive.

* You must use only the screws (3 x 8 mm) and holder that were included with the CD-01A.

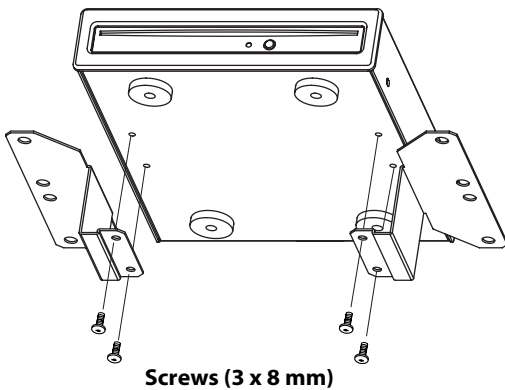

3. Reattach the headphone hook in the location shown in the illustration.

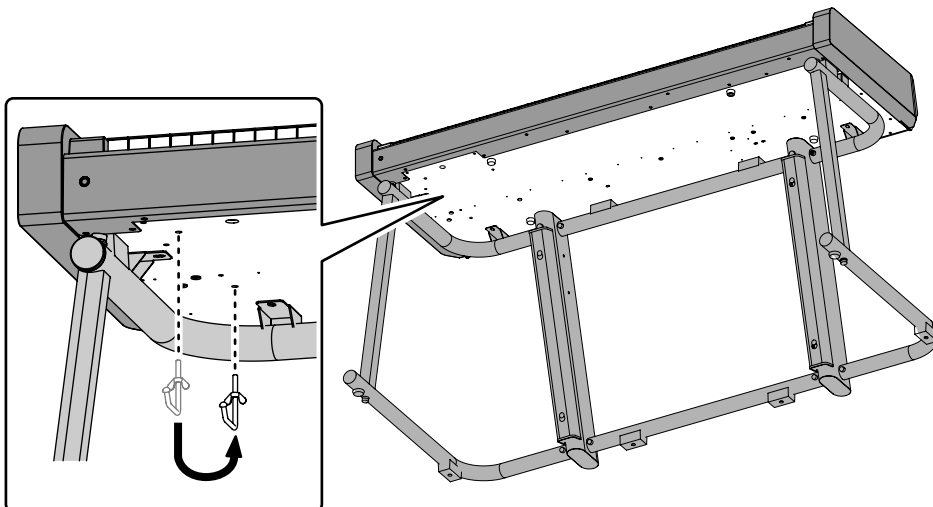

4. Use screws (4 x 16 mm) to attach the CD drive to the holes located on the V-Piano's bottom panel, as shown in the illustration.

* You must use only the screws (4 x 16 mm) that were included with the CD-01A.

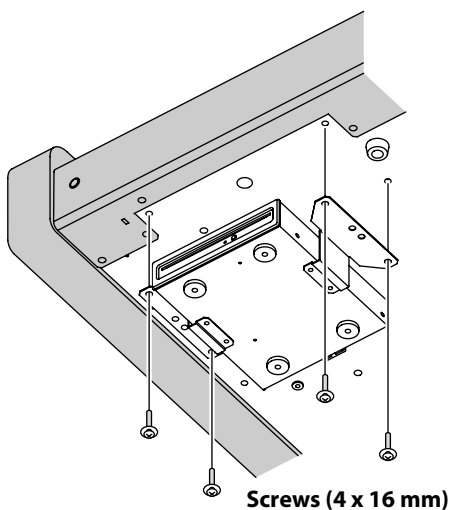

5. Use a USB cable to connect the CD drive's USB connector to the V-Piano's front panel USB memory connector.

MEMO

The USB cable included with the V-Piano can be routed past the V-Piano's back panel and connected.

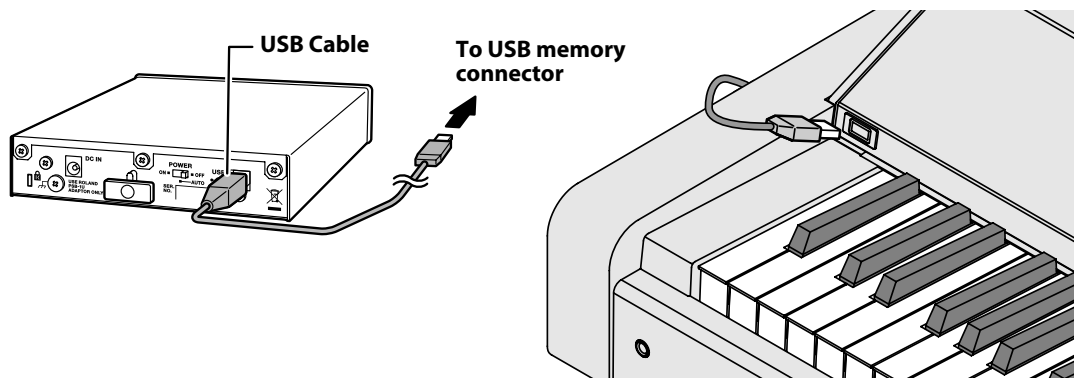

6. Connect the AC adaptor included with the CD drive to the CD drive's DC IN connector.

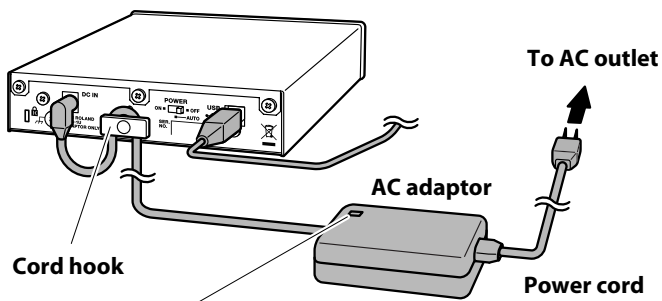

Place the AC adaptor so the side with the indicator faces upwards and the side with textual information faces downwards. The indicator will light when you plug the AC adaptor into an AC outlet.

MEMO

Secure the AC adaptor cord to the cord hook as shown in the illustration. This will prevent accidental disconnection of the cord and loss of power or excessive strain on the AC adaptor jack if the cord is pulled inadvertently.

7. Connect the AC adaptor to an AC outlet.

Introducing the V-Piano

How the V-Piano is structured

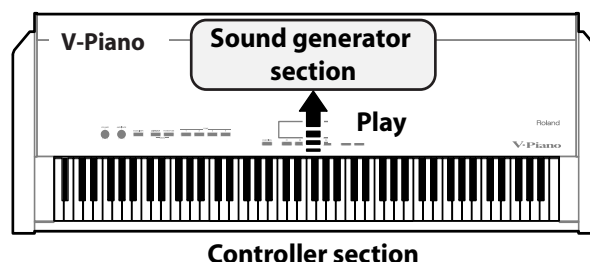

Controller section

This section contains the keyboard, foot controllers such as the pedals, and also includes the panel buttons and knobs. The information generated as the result of playing the keyboard and operating the controllers is sent to the sound generator section.

Sound generator section

This section produces the V-Piano's sounds. The sounds are generated according to the performance data received from the controller section and from external MIDI devices, and sent as an audio signal from the OUTPUT jacks and the headphone jack.

The V-Piano's parameters

Tones

When shipped from the factory, the V-Piano contains 24 "preset tones."
You can customize these preset tones in the V-Piano's Tone screen (p. 29) or by using the included V-Piano Editor (p. 58).
A customized preset tone can be saved in the V-Piano as a "user tone" (p. 51).
The V-Piano can internally store 100 user tones.
You can select and play one of the 24 preset tones or 100 user tones (p. 34).

Setups

A "setup" is a choice of tone together with settings such as pedal assignments.
The V-Piano lets you store 100 setups (p. 60).
You can recall and play one of these 100 setups (p. 59).



When you switch on the V-Piano's power, setup number 001 will be selected automatically. If you save your favorite tone and settings in setup number 001, that sound and those settings will be available to play as soon as you switch on the V-Piano.

System parameters

Settings used by the entire V-Piano are called "system parameters" (p. 80). The values of the system parameters do not change when you switch setups or tones.
If you don't want settings such as pedal settings to change when you switch setups, you can save these settings as system parameters.

Backing up and initializing

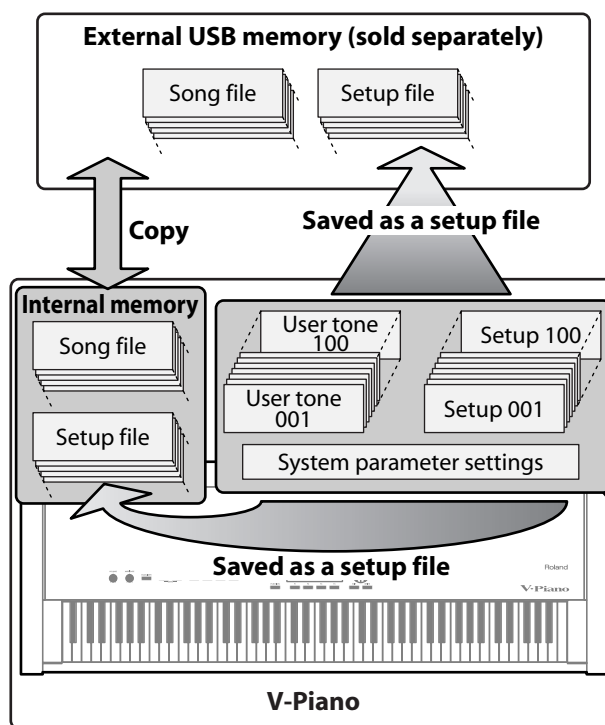

Backing up parameters

The 100 user tones, 100 setups, and system parameter settings can be backed up to the V-Piano's internal memory or to USB memory (sold separately) as a "setup file" (p. 87).

Performance data you've recorded using the V-Piano's Song function is stored in the V-Piano's internal memory as a song file. Song files can be copied between internal memory and USB memory.

Initializing the memory

If you want the user tones, setups, and system parameter settings stored in the V-Piano to be returned to their factory-set state, execute the factory reset operation (p. 99).

If you want the entire contents of internal memory to be completely erased and returned to the factory-set state, initialize the internal memory (p. 95).

* Factory Reset does not erase the contents of internal memory.

If you want to erase the entire contents of USB memory and format the memory for use with the V-Piano, initialize the USB memory (p. 95).

Before new USB memory or USB memory that has been used by a computer or other device can be used with the V-Piano, that USB memory must be initialized (p. 95).

File operations

The setup files and song files saved in V-Piano's internal memory or in USB memory can be copied in units of files (p. 87).

You can also delete specific files if desired (p. 87).

How the V-Piano's screens are organized

Tone screen

The tone screen will appear when you switch on the V-Piano's power.

The tone screen shows information about the currently selected tone.

In the tone screen you can select tones and access various customizations and functions.

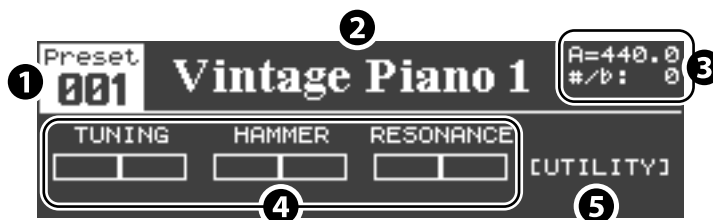

1. Tone number

You can use the [VALUE] dial to select Preset 001–Preset 024 and User 001–User 100 tones (p. 34).

2. Tone name

3. Various information

Various types of information can be shown in this area.



If the utility screen's "1. System–Information Type" setting (p. 80) is set to "BASIC," the following information is shown in this area.

With the factory settings, this is the information that is shown.

Basic information display

A. Master tuning (Master Tune (p. 80))

B. Transposition amount (p. 41)

MEMO

You can change this display by changing the utility screen's "1. System–Information Type" setting (p. 80). For details, refer to "Information shown in the tone screen" (p. 30).

4. Editable tone parameters

You can adjust the settings of these parameters by pressing a [F1]–[F3] button and then turning the [VALUE] dial. For details, refer to "Editing a parameter's value" (p. 50).

You are free to assign desired tone parameters to the [F1]–[F3] buttons "Changing the parameters shown in the tone screen" (p. 53).

5. Utility screen indication

With the factory settings, you can access the utility screen by pressing the [F4] button.

You are free to assign a desired tone parameter to the [F4] button (p. 53).

Information shown in the tone screen

You can change this display by changing the utility screen's "1. System-Information Type" setting (p. 80).

Show the ambience settings

If the utility screen's "1. System-Information Type" setting (p. 80) is set to "AMBIENCE," the ambience settings will be shown.



- A. Ambience mode ("Ambience Mode" (p. 86) setting)
 SYS: When Ambience Mode is set to "SYSTEM"
 SUP: When Ambience Mode is set to "SETUP"
- B. Ambience type ("Ambience Type" (p. 86) setting)
- C. Amount of ambience ("Ambience Level" (p. 86) setting)

Show the pedal assignments

If the utility screen's "1. System-Information Type" setting (p. 80) is set to "PEDAL," the piano pedal assignments will be shown.



- A. Piano pedal mode ("Piano Pedal Mode" (p. 84) setting)
 SYS: When Piano Pedal Mode is set to "SYSTEM"
 SUP: When Piano Pedal Mode is set to "SETUP"
- B. Function controlled by the center piano pedal (p. 46) ("Center Pedal Assign" setting)
- C. Function controlled by the left piano pedal (p. 46) ("Left Pedal Assign" setting)

- * The functions controlled by the pedal are shown as an abbreviation. For the correspondence between the abbreviation and the full name of the function, refer to "Functions that can be assigned to a pedal" (p. 45).
- * Only the first function assigned to the pedal (ASSIGN 1) is displayed.

The tone screen when a function is turned on

If you press the [FUNCTION] button in the tone screen to turn Function on, the content of the lower half of the screen will change.



When Function is turned on, the [FUNCTION] button will light, and functions such as song play/stop or ambience type setting can be assigned to the [F1]–[F3] buttons.

For details on how to make these assignments, refer to "Assigning functions to the [F1]–[F3] buttons" (p. 43).

MEMO

The [F4] button is assigned to access the utility screen. You cannot change this assignment.

Setup select screen

From the tone screen, hold down the [FUNCTION] button and press the [F1] button to access a screen where you can choose a setup.



1. Setup number
2. Setup name
3. Information display area

The basic information shown here is the number of the tone used by the setup. Numbers following “P” are preset tone numbers, and numbers following “U” are user tone numbers.

Song screen

In this screen you can play back SMF music data, audio data, or CD songs. You can also record your own playing. For details, refer to “Playing songs and recording your performances” (p. 64).



Utility screen

In this screen you can make settings for the V-Piano’s various functions. For details on these items and procedures, refer to “Detailed settings for various functions (Utility screen)” (p. 76).



Listening to the demo songs

Here's how to listen to the V-Piano's built-in demo songs.

The V-Piano contains demo songs that let you enjoy its sounds.

* Music Data Copyright: © 2009 Roland Corporation

NOTE

All rights reserved. Unauthorized use of this material for purposes other than private, personal enjoyment is a violation of applicable laws.

NOTE

The performance data of the demo songs is not transmitted from the MIDI OUT connector or USB MIDI connector.

MEMO

When the V-Piano is placed in demo song playback mode, its various settings will revert to the same state as immediately after the power is turned on. If you want to keep your settings, save them in a setup (p. 60).

MEMO

In demo song playback mode, playing the keyboard will not produce sound.

1. Hold down the [V-LINK] button and press the [TRANSCOPE] button; the V-PIANO DEMO screen will appear.

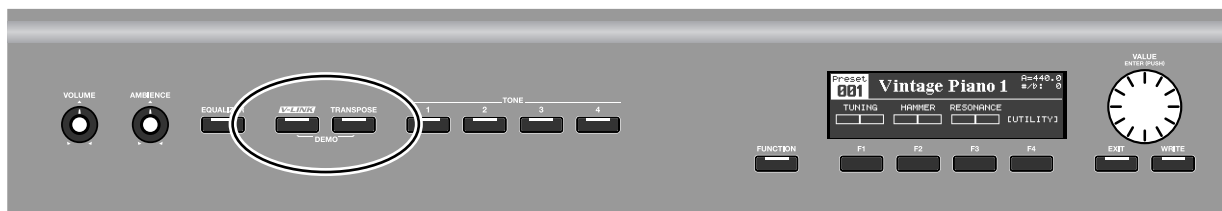

2. Use the [F3 (▲)] / [F4 (▼)] buttons or the [VALUE] dial to select a demo song.

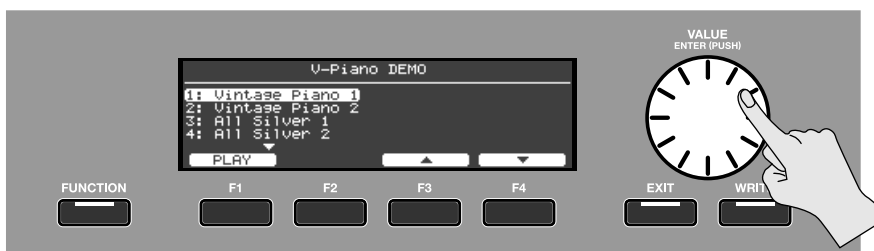

3. To play the selected demo song, press the [F1 (PLAY)] button.

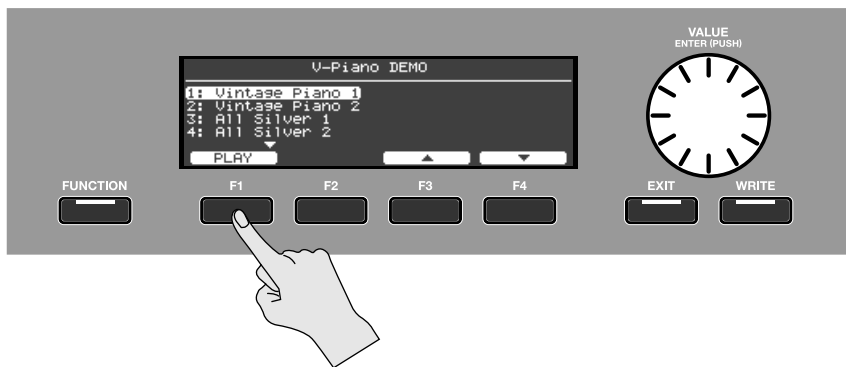

4. The demo song will play.
5. To stop the demo song, press the [F1 (STOP)] button.
6. To exit demo song playback mode, press the [EXIT] button from the V-PIANO DEMO screen.

Selecting and playing a sound

This section explains how to play the V-Piano.

The V-Piano contains 24 different “tones” (preset tones). Here’s how to select and play these tones.

MEMO

The sound will be interrupted when you switch tones, but this does not indicate a malfunction.

1. Access the tone screen.

The tone screen will appear when you switch on the V-Piano’s power.

If any screen other than the tone screen is shown, press the [EXIT] button.

2. Press one of the [TONE 1]–[TONE 4] buttons.

With the factory settings, the following preset tones are assigned to the buttons.

[TONE 1] button: No. 001 Vintage Piano 1

[TONE 2] button: No. 008 Vintage Piano 2

[TONE 3] button: No. 015 All Silver 1

[TONE 4] button: No. 020 All Silver 2

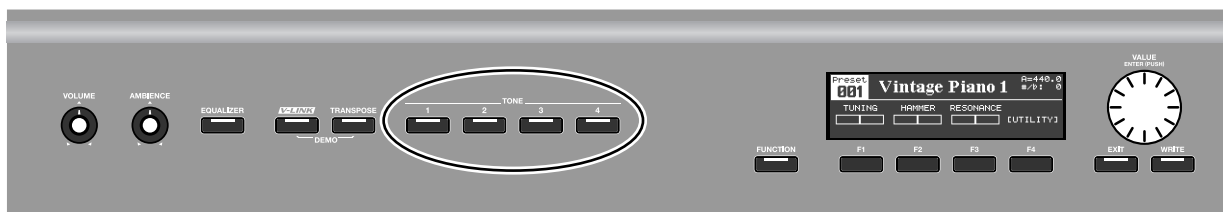

3. Try selecting other preset tones.

Make sure that the tone number is highlighted, and turn the [VALUE] dial.

This allows you to select preset tone numbers 001–024.



MEMO

If the tone number is not highlighted, press the [EXIT] button.

Assigning your favorite tones to the [TONE 1]–[TONE 4] buttons

You can assign your favorite tones to the [TONE 1]–[TONE 4] buttons.

If you turn the [VALUE] dial after pressing one of the tone buttons, the tone will change.

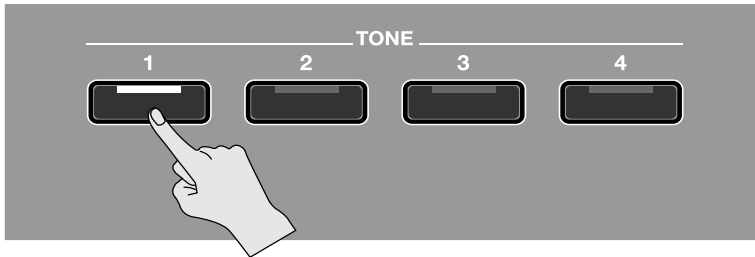

If you press and hold down the tone button for about one second, the currently selected tone will be assigned to that tone button.

Now you can select the newly assigned tone any time simply by pressing that tone button.



This setting is stored in the setup (p. 59).

Recalling a tone you've customized

If you've customized a tone, you can save it as a user tone so that it can be recalled from the tone screen.

For details on customizing a tone and saving it, refer to "Customizing the V-Piano's sounds" (p. 48).

List of preset tones

No.	Tone Name	Piano Type	Characteristics
001	Vintage Piano 1	Vintage	A standard piano that can be used in a broad range of styles, from classical to jazz and pop. The sound is bright and lively, and will respond dynamically to your touch.
002	V1 Studio	Vintage	A small-sized piano with a lighter resonance.
003	V1 Concert	Vintage	A large-sized piano with long bass strings and a large sounding board.
004	V1 Session	Vintage	A clear-sounding piano.
005	V1 Mellow	Vintage	A mellow-sounding piano.
006	V1 Bright	Vintage	A bright-sounding piano.
007	V1 Honky Tonk	Vintage	Honky tonk piano.
008	Vintage Piano 2	Vintage	A tranquil-sounding piano with a European atmosphere. With softly played notes, the sound is particularly clear and transparent. This is ideal for mellow ballades. Enjoy the blissful pianissimo notes.
009	V2 Studio	Vintage	A small-sized piano with a lighter resonance.
010	V2 Concert	Vintage	A large-sized piano with long bass strings and a large sounding board.
011	V2 Session	Vintage	A clear-sounding piano.
012	V2 Clear	Vintage	A transparent-sounding piano.
013	V2 Upright	Vintage	An upright piano.
014	Fortepiano	Vintage	This is the sound of a fortepiano, an early piano that has a somewhat different character than today's pianos. Use a lighter key touch setting to appreciate the historical atmosphere of this period instrument.
015	All Silver 1	Vanguard	A piano that's triple-strung all the way through the bass notes, with silver winding all the way through the treble notes.
016	All Triple	Vanguard	A piano that's triple-strung all the way through the bass notes, with copper winding all the way through the treble notes.
017	Glass Piano	Vanguard	A piano with a sounding board made of a hard material, producing a sense of transparency.
018	Silver Dynamic	Vanguard	A piano that delivers a wide range of tonal variation between softly played and strongly played notes.
019	Silver Extreme	Vanguard	A piano with emphasized metallic resonance.
020	All Silver 2	Vanguard	A piano that's triple-strung all the way through the bass notes, with silver winding all the way through the treble notes.
021	Triple Power	Vanguard	A piano with a bright and powerful resonance.
022	Triple Mellow	Vanguard	A piano with a deep and gentle resonance.
023	Deep Resonant	Vanguard	A piano with a sense of movement as though the entire piano were resonating more intensely.
024	Hybrid Silver	Vanguard	A piano that combines elements from multiple pianos of differing characters.

Adjusting the tonal character (Equalizer)

The V-Piano contains a four-band equalizer which you can use to adjust the tonal character.



This equalizer applies to all sound that is output from the V-Piano.

1. Press the [EQUALIZER] button.

The equalizer will turn on. The [EQUALIZER] button will light, and the equalizer screen will appear in the display.

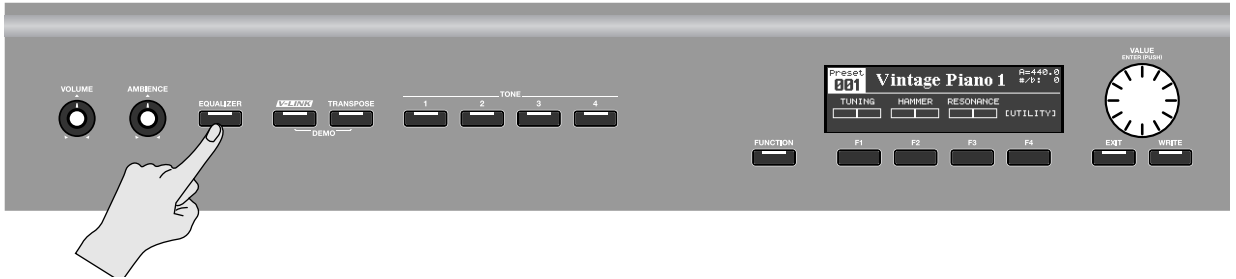

2. Use the [F1]–[F4] buttons and the [VALUE] dial to edit the equalizer parameters.

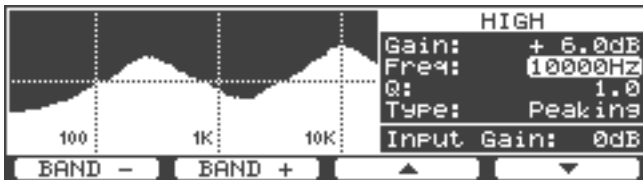

The equalizer screen contains a frequency response graph that shows the combined result of the four bands. The currently selected band and its parameter settings are shown at the right of the graph.

- Use the [F1 (BAND -)] or [F2 (BAND +)] button to switch bands.
- Use the [F3 (▲)] / [F4 (▼)] button to select the parameter you want to edit.
- Turn the [VALUE] dial to edit the value of the selected parameter.

Band	Parameter	Value	Description
LOW	Gain	-12~+12 dB	Gain of this band.
	Freq	16–16000 Hz	Center frequency of this band.
	Q	0.5, 1.0, 2.0, 4.0, 8.0	Bandwidth. Higher values will narrow the frequency range of the band.
	Type	Shelving, Peaking	Shelving: This type boosts/cuts the region below the specified center frequency. Peaking: This type boosts/cuts only the region around the specified center frequency.
LOW MID HIGH MID	Gain	-12~+12 dB	Gain of this band.
	Freq	16–16000 Hz	Center frequency of this band.
	Q	0.5, 1.0, 2.0, 4.0, 8.0	Bandwidth. Higher values will narrow the frequency range of the band.
HIGH	Gain	-12~+12 dB	Gain of this band.
	Freq	16–16000 Hz	Center frequency of this band.
	Q	0.5, 1.0, 2.0, 4.0, 8.0	Bandwidth. Higher values will narrow the frequency range of the band.
	Type	Shelving, Peaking	Shelving: This type boosts/cuts the region above the specified center frequency. Peaking: This type boosts/cuts only the region around the specified center frequency.
(Common)	Input Gain	-15~+15 dB	Adjusts the overall level of the equalizer.



Some equalizer settings may cause distortion. If so, reduce the Input Gain.

3. To turn the equalizer off, press the [EQUALIZER] button.

The [EQUALIZER] button will go out, and the previous screen will reappear.



By pressing the [EXIT] button you can return the previous screen while leaving the equalizer on.

Saving the equalizer settings

NOTE

Equalizer settings are saved in system memory.

MEMO

You can also store the equalizer settings in a setup. Refer to EQ Mode in “System settings (1. System)” (p. 80). If you’ve chosen to store the equalizer settings in each setup, the equalizer settings will also be stored when you store the setup (p. 60).

1. From the Tone screen, press the [FUNCTION] button to turn Function on.

The [FUNCTION] button will light.

2. Press the [F4 (UTILITY)] button.

3. Use the [F3 (▲)] or [F4 (▼)] buttons to select “1. System.”



4. Press the [ENTER] button or the [F1 (ENTER)] button to access the system setting screen.

5. Press the [WRITE] button.



6. A confirmation message will appear. To save the equalizer settings, press the [F4 (OK)] button.

MEMO

The equalizer settings, as well as any system parameters you’ve edited will be saved in System memory.

If you decide to cancel without saving, press the [F1 (CANCEL)] button.

Adding reverberation to the sound (Ambience)

The ambience settings allow you to add reverberation to the sound.

By applying ambience, you can enjoy the sensation of performing in a large hall or other acoustic space.

Turn the [AMBIENCE] Knob toward the right to increase the ambience effect.

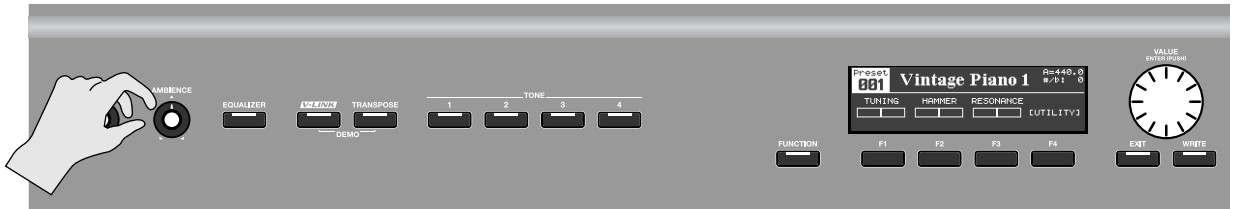

Switching the ambience type

The V-Piano provides twelve types of ambience

1. Turn the [AMBIENCE] Knob while holding down the [FUNCTION] button.

The ambience editing screen will appear.



2. Use the [F1]–[F4] buttons and the [VALUE] dial to change the Ambience Type.



MEMO

For details on the ambience types and how to edit the ambience settings, refer to “Ambience settings (6. Ambience)” (p. 86).

Saving the ambience settings

Ambience settings are saved in system memory.

MEMO

You can also store the ambience settings in a setup. Refer to Ambience Mode in "Ambience settings (6. Ambience)" (p. 86). If you've chosen to store the ambience settings in each setup, the ambience settings will also be stored when you store the setup (p. 60).

1. From the Tone screen, press the [FUNCTION] button to turn Function on.

The [FUNCTION] button will light.

2. Press the [F4 (UTILITY)] button.

3. Use the [F3 (▲)] or [F4 (▼)] buttons to select "1. System."

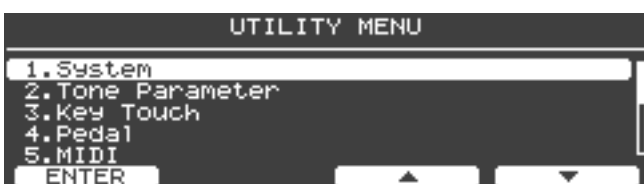

4. Press the [ENTER] button or the [F1 (ENTER)] button to access the system setting screen.

5. Press the [WRITE] button.



6. A confirmation message will appear. To save the ambience settings, press the [F4 (OK)] button.

MEMO

The ambience settings, as well as any system parameters you've edited will be saved in System memory.

If you decide to cancel without saving, press the [F1 (CANCEL)] button.

Shifting the pitch (Transpose)

The “Transpose” function lets you change the pitch without changing your keyboard fingering.

This is convenient when you need to play in a different key in order to match the range of a vocalist, or when playing from notation that was written for a transposing instrument such as a trumpet.

The transposition range is from -1 octaves (-12 semitones) to +1 octaves (+12 semitones) in semitone steps.

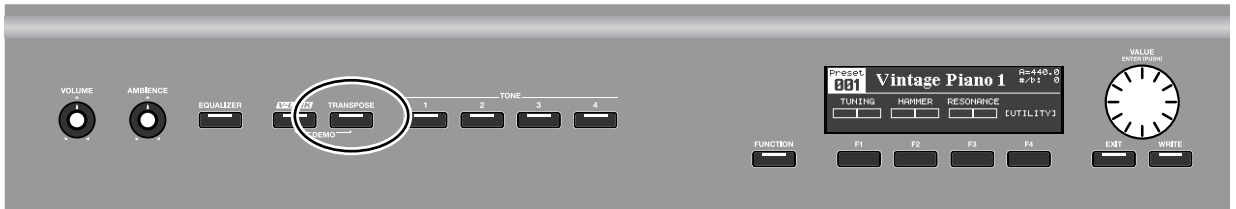

NOTE

If the transposition setting causes any keys to exceed the range of A0–C8, those keys may sound one octave higher (or lower).

MEMO

The MIDI OUT connector and USB MIDI connector will transmit note messages as transposed by this setting.

MEMO

Note messages received via the MIDI IN connector or USB MIDI connector will not be transposed.

1. While holding down the [TRANPOSE] button, press a key.

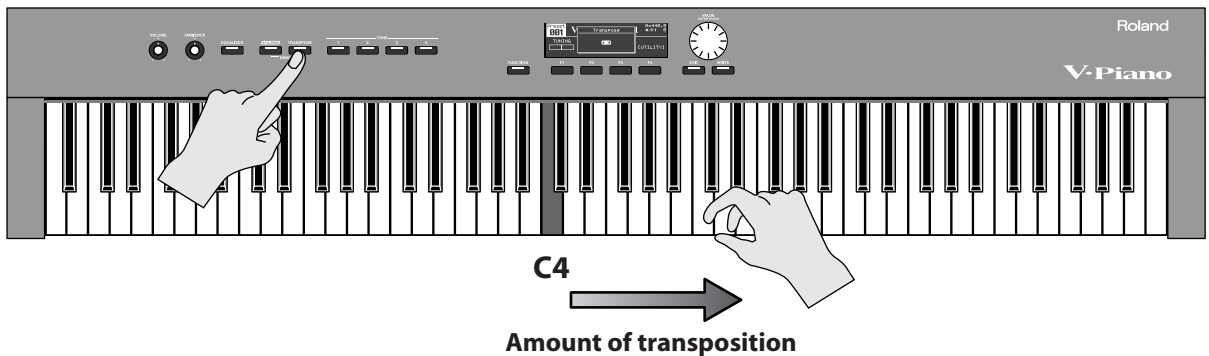

For example, if you want the “E” pitch to sound when you play the “C” key, hold down the [TRANPOSE] button and press the E4 key. This specifies a transposition setting of “+4.”



The previous screen will reappear when you release the [TRANPOSE] button.

If you’ve specified a transposition, the Transpose function will be on and the [TRANPOSE] button will light. If the transposition amount is “0,” the indicator will not light even if you press the [TRANPOSE] button.

MEMO

You can also change the amount of transposition by turning the [VALUE] dial.

2. To turn off the Transpose function, press the [TRANPOSE] button so its indicator goes out.

The next time you press the [TRANPOSE] button, the pitch will be transposed by the amount you specified.

Disabling the buttons (Panel Lock)

If you lock the panel, all button operations of the V-Piano will be disabled.

For example, you can use this to keep the settings from being changed inadvertently while performing on stage.

NOTE

The [VOLUME] Knob and [AMBIENCE] Knob are not locked even if the panel lock function is active.

1. Hold down the [FUNCTION] button and press one of the [TONE 1]–[TONE 4] buttons.

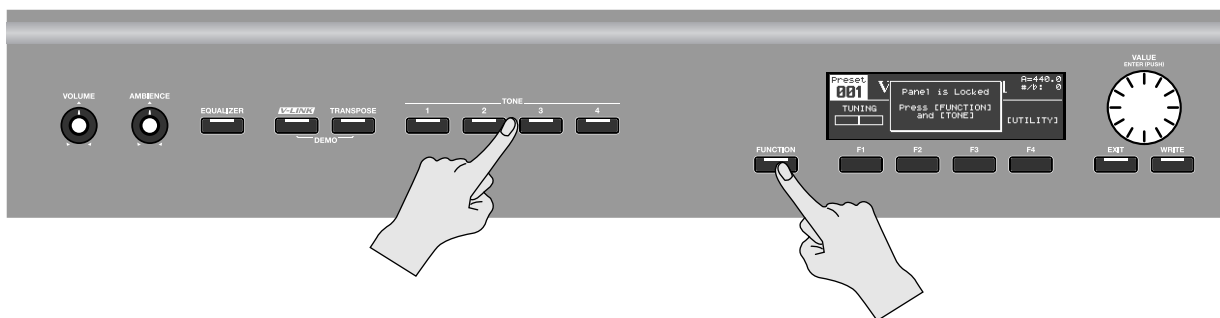

The panel will be locked, and the screen will show a message indicating this.

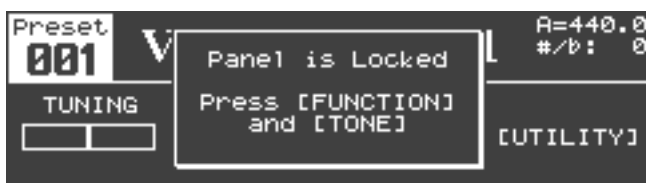

2. To unlock the panel, perform step 1 once again.

Assigning functions to the [F1]–[F3] buttons

You are free to assign functions to the [F1]–[F3] buttons.

This allows you to rapidly access the function you need.

MEMO

The [F4] button is assigned to access the utility screen. You cannot change this assignment.

MEMO

Button assignments are stored in the setup (p. 60).

1. Press the [FUNCTION] button to turn Function on.

The [FUNCTION] button will light.

2. Press and hold one of the [F1]–[F3] buttons.

A list of the assignable functions will appear.



3. While continuing to hold the [F1]–[F3] button, turn the [VALUE] dial to select the desired function.

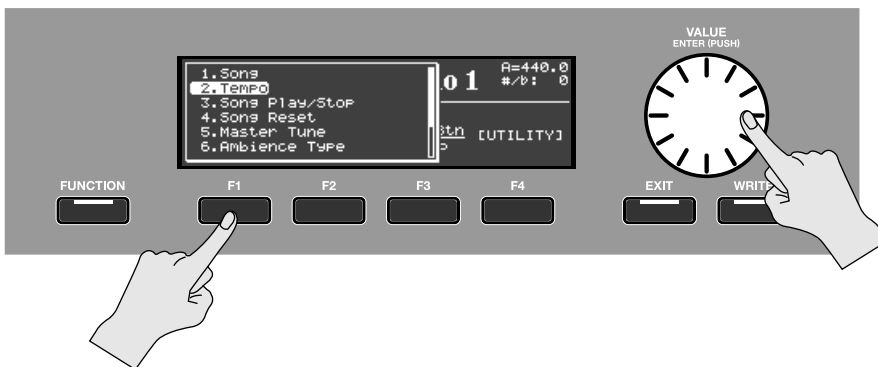

4. Release the [F1]–[F3] button.

The selected function is assigned to that button.



List of assignable functions

Indication (abbreviation)	Function name	Description	See page
Song	Song	Show the song screen	p. 64
Tempo	Tempo	Song tempo setting	p. 74
Play/Stop	Song Play/Stop	Song Play/Stop	p. 66
SongReset	Song Reset	Return to the beginning of the song	p. 64
MastrTune	Master Tune	Reference pitch setting	p. 80
Ambience	Ambience Type	Ambience type setting	p. 39
Pedal	Pedal Assign	Show the pedal screen	p. 46
Tone Btn	Tone Button Mode	Choose whether the [TONE 1]–[TONE 4] buttons will select tones or setups	p. 81
MIDI Out	MIDI Out Switch	MIDI output on/off	–

Using the pedals to control the V-Piano's functions

You can assign various functions to the piano pedals and to pedals connected to the PEDAL FC1 jack and PEDAL FC2 jack, and use these pedals to control the V-Piano.

MEMO

You can assign functions to the left piano pedal and the center piano pedal.

MEMO

The right piano pedal and the pedal connected to the PEDAL DAMPER jack will always operate as damper pedals. You cannot change these assignments.

Functions that can be assigned to a pedal

Function	Value	Together with another function	Abbreviation in the tone screen	Remarks
Operate as soft pedal	SOFT	✓	Soft	
Operate as sostenuto pedal	SOSTENUTO	✓	Sosten	
Turn on/off MIDI output of performance data	MIDI OUT SW		M.Out	
Play/stop the selected song	SONG PLAY/STOP		PlayST	
Turn transpose on/off	TRANPOSE SW		Trans	Linked with the [TRANPOSE] button.
Move the playback position to the beginning of the song	SONG RESET		Reset	
Adjust the volume of the entire V-Piano	MASTER VOLUME	✓	Volume	Linked with the utility screen's "1. System–Master Volume."
The V-Piano's volume	EXPRESSION	✓	Expres	
Adjust the ambience	AMBIENCE LEVEL	✓	AmbLvl	Linked with the [AMBIENCE] Knob.
Adjust the tone parameter	SOUND LIFT	✓	S.Lift	
	STRING RESONANCE	✓	S.Reso	
	DAMPER RESONANCE	✓	D.Reso	
	SOUNDBOARD RESO	✓	Sndbd	The name of the tone parameter is "Soundboard Resonance"
	KEY OFF RESONANCE	✓	K.Reso	
	UNISON TUNE	✓	Tuning	
	HAMMER HARDNESS	✓	Hammer	
	CROSS RESONANCE	✓	C.Reso	
	DECAY TIME	✓	Decay	
	TONE COLOR	✓	TColor	
	DAMPING TIME	✓	D.Time	
DAMPER NOISE LEVEL	✓	D.Nois		
Recall the next setup	SETUP UP		SUP.Up	
Recall the preceding setup	SETUP DOWN		SUP.Dn	

MEMO

Parameters for which a check mark appears in the "Together with another function" column allow two functions to be simultaneously assigned to a single pedal.

NOTE

SETUP UP and SETUP DOWN can be selected only if the pedal settings are the settings stored in system memory.

NOTE

The "Abbreviation in the tone screen" will be displayed when PEDAL has been set for Information Type (p. 80).

Assigning a function to a pedal

1. In the tone screen, press the [FUNCTION] button to turn Function on.

The [FUNCTION] button will light.

2. Press the [F4 (UTILITY)] button to access the utility screen.

3. Use the [F3 (▲)] or [F4 (▼)] buttons to select "4. Pedal."

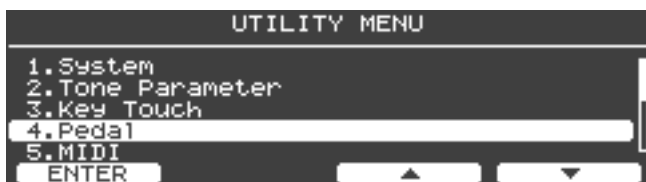

4. Press the [ENTER] button or the [F1 (ENTER)] button to access the pedal setting screen.



5. Use the [F3 (▲)] or [F4 (▼)] button to select the pedal whose assignment you want to change.



Parameters	Pedal
Center Pedal Assign	Center piano pedal
Left Pedal Assign	Left piano pedal
FC2 Assign	Connected to the PEDAL FC2 jack
FC1 Assign	Connected to the PEDAL FC1 jack

6. Turn the [VALUE] dial to select the function you want to assign.

MEMO

If you select "OFF," that pedal will not control anything.

7. Use the [F3 (▲)] or [F4 (▼)] buttons to specify the states of the assigned function when the pedal is released and when it is pressed to its maximum extent.

Parameters	Description
Center Pedal Min Left Pedal Min FC2 Min FC1 Min	Specify the state when the pedal is released
Center Pedal Max Left Pedal Max FC2 Max FC1 Max	Specify the state when the pedal is pressed to the maximum extent

MEMO

The available values will depend on the function you've assigned.

8. If you want to assign two parameters (that allow simultaneous assignment with another function), press the [F1 (ASSIGN1/2)] button to access the ASSIGN 2 screen.
9. In the ASSIGN 2 screen, make settings for the second function.



10. When you've finished making settings, press the [EXIT] button to return to the previous screen.

MEMO

By default, pedal settings are stored in the setup. If you want to keep the pedal settings you've made, save the setup (p. 60).

MEMO

If desired, you can prevent the pedal assignments from changing when you switch setups. For details, refer to "Pedal settings (4. Pedal)" (p. 84).

Customizing the V-Piano's sounds

The V-Piano contains twenty-four different "tones."

These sounds are produced by a virtual piano inside the V-Piano. Unlike the way in which conventional digital pianos create sound by processing samples recorded from an acoustic piano, the V-Piano uses digital signal processing to model the numerous elements that make up an acoustic piano, and combines these to create the sound of the piano.

The twenty-four "tones" built into the V-Piano are not simple variations of the sound. Rather, they are forms of pianos constructed within the V-Piano. By customizing these tones you can construct your very own piano.

The V-Piano's parameters

Sound Lift

Range: 0--+100

This changes how the sound is produced when you play the keyboard softly.

You can adjust this to make the sound suitable for solo playing, or to prevent your sound from being buried by the other instruments of your band.

With higher settings, the sound will be relatively loud even when you play lightly, preventing your sound from being lost in the band.

Soft Pedal Sense

Range: -100--+100

This adjusts the sensitivity of the soft pedal.

String Resonance

Range: -100--+100

This adjusts the sympathetic vibration of the strings that occurs when you play the keyboard.

This simulates not only the sympathetic vibration that occurs when you play a single note, but also the sympathetic vibration that occurs in strings that are already sounding when you play subsequent notes.

Increasing this value will produce a greater effect.

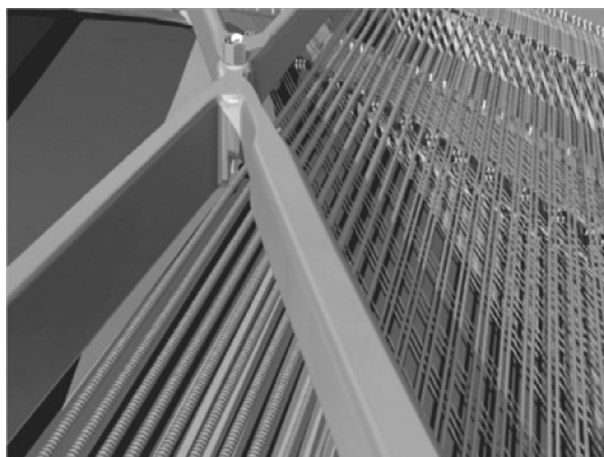

Damper Resonance

Range: -100--+100

This adjusts the damper resonance of an acoustic piano; i.e., the sound of other strings sympathetically vibrating when you play other keys with the damper pedal held down.

Increasing this value will increase the loudness of the sympathetic vibration.

Soundboard Resonance

Range: -100--+100

This adjusts the sound of the soundboard resonating in response to the notes you play.

Increasing this value will increase the soundboard resonance.

Key Off Resonance

Range: -100--+100

This adjusts the amount of resonances such as an acoustic piano's key-off sound (the subtle sound that occurs when you release a key).

Increasing this value will increase the amount of resonance.

Unison Tune

Range: -100→+100

Normally, there are three strings for each key of a piano (lower notes have one or two strings). A beautiful resonance can be created by slightly detuning the pitch of these strings.

Adjusting this parameter to a higher positive (+) value will increase the pitch differences between the 2nd string and the 1st and 3rd strings.

When this value is 0, the three strings will be detuned as they are on a typically tuned piano.

Adjusting this parameter to a lower negative (-) value will decrease the pitch differences between the 2nd string and the 1st and 3rd strings. With the setting of -100, the pitch differences between the three strings will be minimum.

MEMO

For keys that have only one string, adjusting this parameter will have no effect.

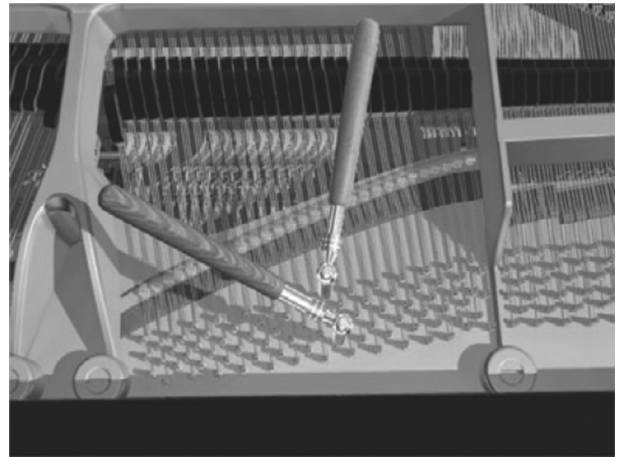

Stretch Tune

Most pianos are tuned so that the lower range is flatter and the upper range is sharper than the theoretically calculated pitches of equal temperament. This makes chords sound more beautiful. This method of tuning is distinctive to pianos, and is called "Stretch Tuning."

For details, refer to "Editing the stretch tune" (p. 54).

Hammer Hardness

Range: -100→+100

This adjusts the hardness of the hammer felt.

Increasing this value will make the felt harder, producing a bolder sound.

Decreasing this value will make the felt softer, producing a softer tone.

Cross Resonance

Range: -100→+100

This adjusts the proportion of the various parasitic vibrations that occur along with the basic vibration of the strings, which produces the basic sound of the piano.

Increasing this value will increase the proportion of the parasitic vibration.

For the strings of the low notes in particular, this will increase the metallic resonance of the high-frequency range.

Lowering this value will decrease the proportion of the parasitic vibration.

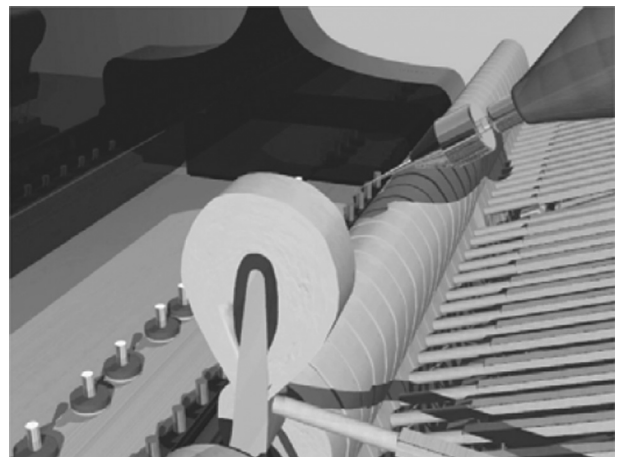

Decay Time

Range: -100→+100

This adjusts the time over which the volume decays after reaching its peak.

Increasing this value will lengthen the time over which the volume decays; reducing this value will shorten the time.

Tone Color

Range: -7--+7

This adjusts the tone color of the strings.

Increasing this value will produce a sharper and brighter sound as though the strings had become thinner.

Decreasing this value will produce a milder and warmer sound as though the strings had become thicker.

Damping Time

Range: -100--+100

This adjusts the time from when the damper touches the strings until the sound disappears; i.e., the length of the release.

Increasing this value will lengthen the release, and decreasing this value will shorten the release.

Damper Noise Level

Range: -100--+100

This adjusts the damper noise of an acoustic piano; i.e., the sound that is heard when you press the damper pedal to release the strings.

Increasing this value will increase the sound heard when the strings are released.

Editing a parameter's value

The tone screen shows some of the parameters that can be customized.

Press the [F1]–[F4] buttons located below the parameter that you want to edit, and then turn the [VALUE] dial to edit that parameter.

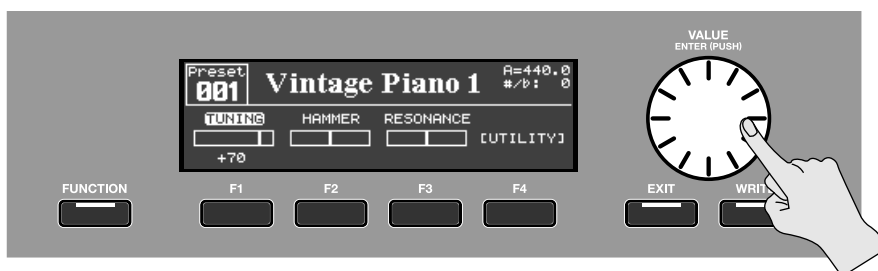

Saving a tone you've customized

If you switch to a different tone or turn off the V-Piano's power after customizing a tone, the changes you've made will be lost. If you want to keep the customized tone, use the following procedure to save it as a user tone.

MEMO

The sound may be interrupted when you switch tones, but this interruption will be minimal when you're switching between tones that were customized from the same preset tone. When using the [VALUE] dial to switch tones during a performance, you may want to make sure that tones that were customized from the same preset tone are stored in adjacent tone numbers.

MEMO

For more about tones customized from the same preset tone, refer to "Viewing the original tone" (p. 58).

1. When you've finished customizing the tone, press the [WRITE] button to access the Tone Write screen.

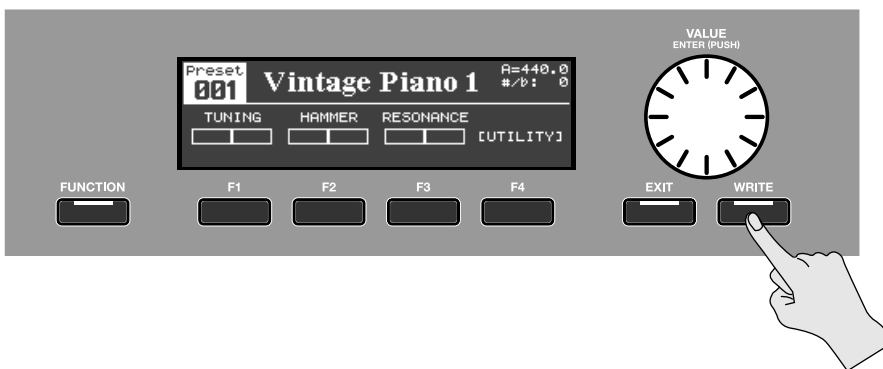

2. Assign a name to the tone. Press the [F2 (RENAME)] button.

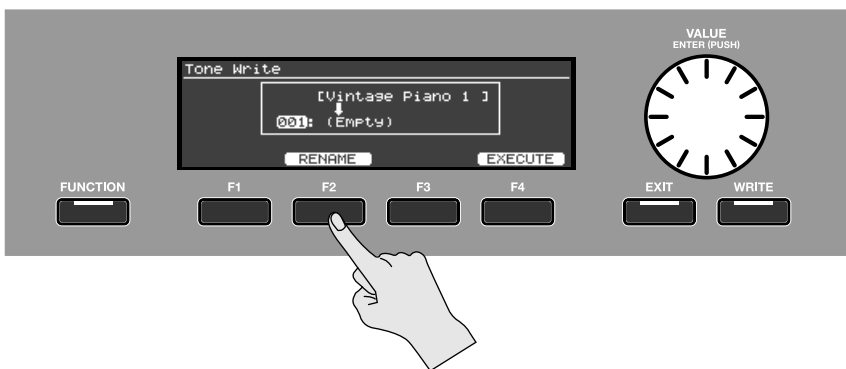

3. Enter the desired name as follows.



- Use the [VALUE] dial to change the character.
- Use the [F1 (INSERT)] button to insert a blank space.
- Use the [F2 (DELETE)] button to delete the character at the cursor location.
- Use the [F3] button to move the cursor one place to the left.
- Use the [F4] button to move the cursor one place to the right.

4. When you've finished entering the name, press the [ENTER] button or [EXIT] button to return to the previous screen.



5. Turn the [VALUE] dial to select the write-destination tone number.

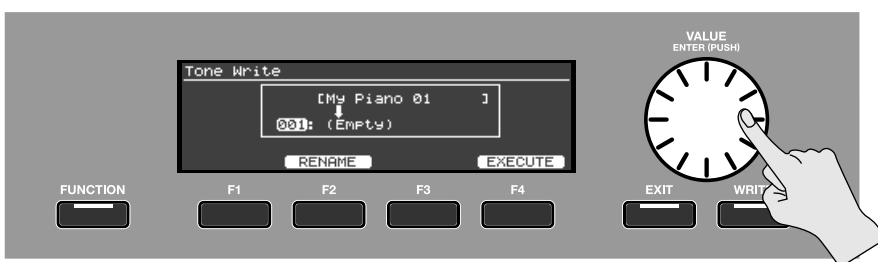

6. Press the [F4 (EXECUTE)] button to save the tone.

7. A confirmation screen will appear; press [F4 (OK)].

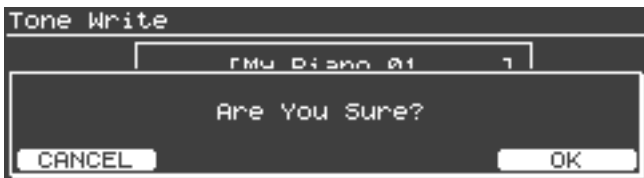

If you decide to cancel without saving, press [F1 (CANCEL)].

NOTE

The display will indicate "Executing..." while the data is being saved. Never turn off the power during this time.

8. When the data has been saved, press the [EXIT] button to return to the previous screen.

Changing the parameters shown in the tone screen

1. Press and hold down one of the function buttons [F1]–[F4].

A list of the tone parameters will appear.



2. Continuing to hold down the function button, turn the [VALUE] dial to select the desired parameter.



3. Release the function button.

The parameter you selected is now assigned to that function button.



MEMO The state of the button assignments is saved in the tone (p. 51).

MEMO The function of opening the utility screen ([Utility]) can be assigned only to the [F4] button.

MEMO The parameters assigned to the function buttons are indicated using the following abbreviations.

Displayed (abbreviated form)	Parameter Name
SOUNDLIFT	Sound Lift
STR.RESO	String Resonance
SND.BOARD	Soundboard Resonance
TUNING	Unison Tune
HAMMER	Hammer Hardness
DECAY	Decay Time
DMP.TIME	Damping Time

Displayed (abbreviated form)	Parameter Name
SOFTPEDAL	Soft Pedal Sense
DMP.RESO	Damper Resonance
KEYOFF	Key Off Resonance
STRETCH	Stretch Tune
RESONANCE	Cross Resonance
TONECOLOR	Tone Color
DMP.NOISE	Damper Noise Level

Editing the stretch tune

The stretch tune settings allow you to make detailed adjustments to the tuning curve.

1. Assign Stretch Tune (STRETCH) to one of the [F1]–[F4] buttons and select it.
2. Press the [ENTER] button to access the Stretch Tune edit screen.



Function Button	Description
[F1 (Lower)]	Specifies the tuning curve for the lower region. <ul style="list-style-type: none"> • Gentle: Draws a curve that is shallower than "Standard." • Standard: Draws a typical curve. • Deep: Draws a curve that is deeper than "Standard."
[F2 (Key)]	Press the [F2 (Key)] button and then press a key; now you can use the [VALUE] dial to adjust the pitch of that key. The range of adjustment is -50–+50 cents.
[F3 (Upper)]	Specifies the tuning curve for the upper region. <ul style="list-style-type: none"> • Gentle: Draws a curve that is shallower than "Standard." • Standard: Draws a typical curve. • Deep: Draws a curve that is deeper than "Standard."
[F4 (Reset)]	Cancels the changes and sets the tuning curve to Standard.

MEMO

If you use the [F2 (Key)] button to edit the tuning of a specific key, the Lower type will automatically change to "User" for G#4 or lower keys and the Upper type for A4 or higher keys.

Editing individual keys

The following parameters can be individually edited for each key.

- Soft Pedal Sense
- Unison Tune
- Hammer Hardness
- Cross Resonance
- Decay Time
- Tone Color
- Damping Time

1. Assign Stretch Tune (STRETCH) to one of the [F1]–[F4] buttons and select it.
2. Press the [ENTER] button to access the edit screen.



Button	Function
[F1 (RangeSet)]	Specifies the key to be edited.
[F2 (Clear)]	Returns the values for all keys to their initial state, as prescribed by the selected tone.
[F3 (Velocity)]	Edits the velocity follow setting.

MEMO

Press the [F2 (Clear)] button and a confirmation screen will appear. If you're sure that you want to return the values for all keys to their initial state (as prescribed by the tone that's selected), press the [F4 (OK)] button. If you decide that you don't want to do this, press the [F2 (CANCEL)] button.

Specifying the key range (RangeSet)

Press the [F1 (RangeSet)] button to specify the key(s) that you want to edit.

To edit the setting of an individual key

1. Press the [F1 (RangeSet)] button.
2. Play the key whose setting that you want to edit.

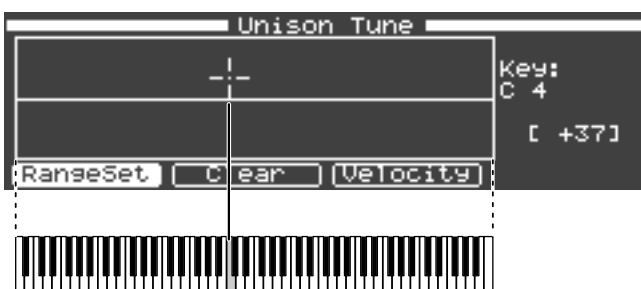

3. Use the [VALUE] dial to edit the setting.
4. Press the [F1 (RangeSet)] button once again to return to the parameter setting screen.

To edit the setting of multiple keys simultaneously

1. Press the [F1 (RangeSet)] button.
2. Hold down two keys to specify the desired range.

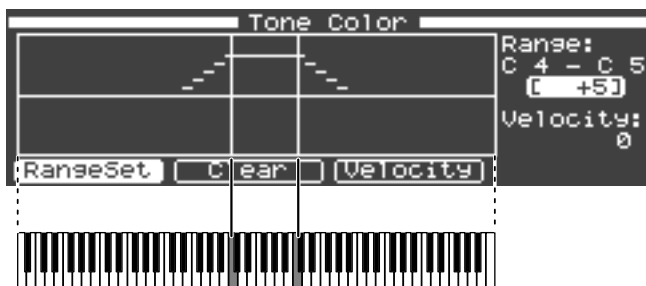

3. Use the [VALUE] dial to edit the setting.

The setting will be changed for the range between the two keys you specified. Beyond that range, settings will be made automatically to create a smooth transition.

4. Press the [F1 (RangeSet)] button once again to return to the parameter setting screen.

MEMO

If you play three keys simultaneously or hold down the damper pedal and play three keys...

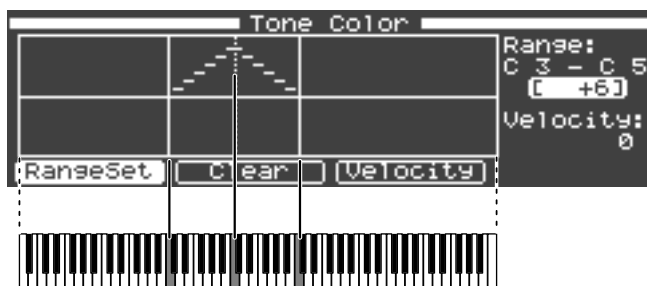

The values will not be edited for the keys at the two ends of the range; the value will be edited for the center key. Settings will be made automatically to create a smooth transition between the center key and the two ends of the key range.

Velocity Follow settings

The following parameters can be made to vary according to the force with which you strike the key.

- Unison Tune
- Hammer Hardness
- Cross Resonance
- Decay Time
- Tone Color

"Velocity Follow" refers to the way in which the strength of an effect changes according to the keyboard playing dynamics.

1. Press the [F3 (Velocity)] button.

2. Turn the [VALUE] dial to adjust the Velocity Follow setting.

With positive (+) values, the effect will increase as you play more strongly.

With negative (-) values, the effect will increase as you play more softly.

With positive (+) values of Velocity Follow

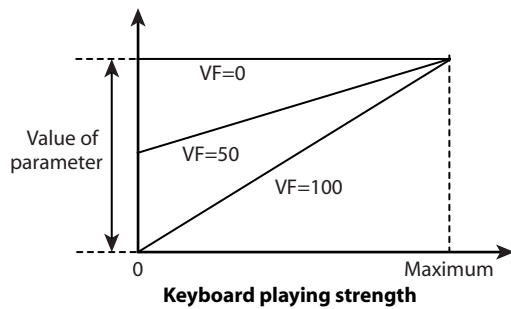

With negative (-) values of Velocity Follow

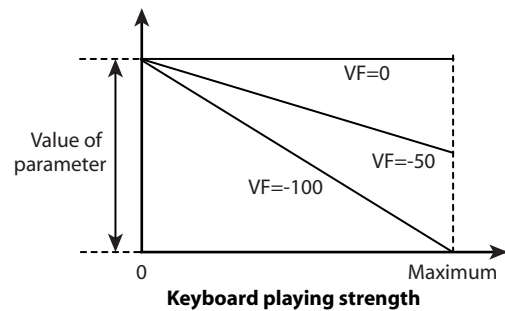

Unison Tune parameters

Unison Tune allows you to tune the 1st string and 3rd string independently.

In the parameter setting screen, you can press the [F4 (String)] button repeatedly to make fine adjustments to the pitch of the 1st string and 3rd string.

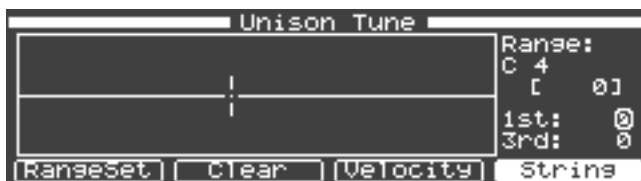

MEMO

Editing this parameter will have no effect for keys that are strung with only one string.

Viewing the original tone

By accessing the utility screen "2. Tone Parameter" you can view the preset tone that was the basis of your customizations.

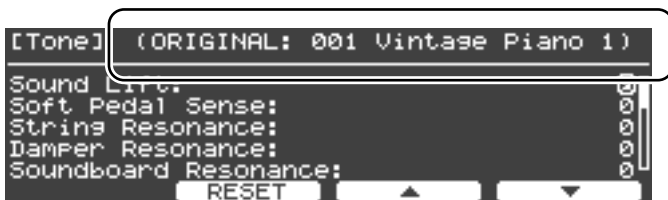

MEMO

In some cases, the sound may be briefly interrupted when you switch tones; however, interruptions will be less likely when you switch between a preset tone and a tone that was customized from that same preset tone. If you're using a pedal to switch between setups, it's best if the setups contain tones that were customized from the same preset tones.

About V-Piano Editor

The included CD-ROM contains "V-Piano Editor" software, which lets you visually customize the V-Piano's tones from your computer (Windows or Mac OS X).

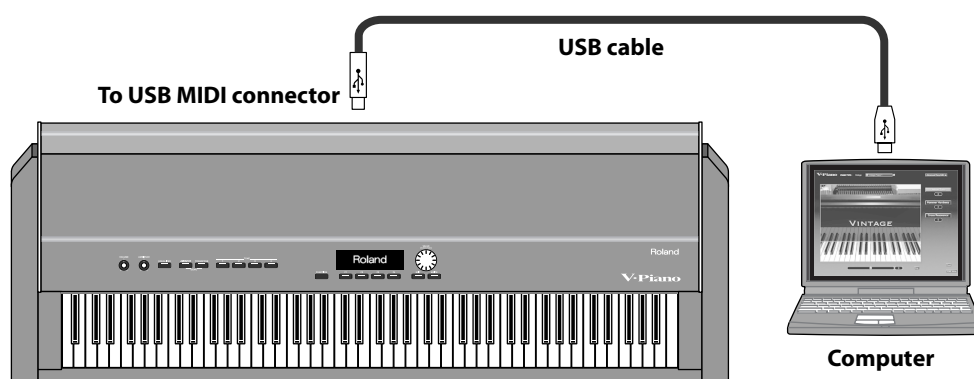

You can use a USB cable to connect the V-Piano to your computer, and customize the V-Piano's parameters in real time from your computer.

For details on the operating requirements and how to use the editor, refer to the online documentation provided on the CD-ROM.

- * Specifications and content of V-Piano Editor are subject to change for improvement without notice.
- * Windows® is known officially as: "Microsoft® Windows® operating system."
- * Microsoft and Windows are registered trademarks of Microsoft Corporation.
- * Apple and Mac OS are registered trademarks of Apple Inc.

Saving your settings (Setups)

You can save the V-Piano's various settings as a "setup" and switch between different setups as appropriate for the songs you're playing.



The setups you save can be backed up to USB memory (sold separately) (p. 85).

Recalling a setup



The current settings will be lost when you recall another setup. If you want to keep the current settings, save them to a setup before you continue (p. 58).

1. Hold down the [FUNCTION] button and press the [F1] button.



2. The number of the currently selected setup will appear.

* You can also view the setup number by changing the utility screen's "1. System-Tone Button Mode" (p. 81) setting to "SETUP."



3. Turn the [VALUE] dial to select the desired setup.

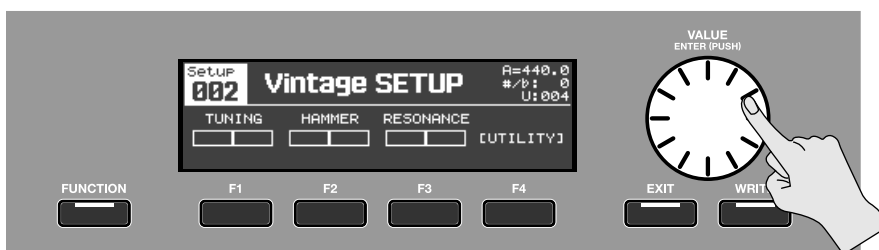

4. Once again hold down the [FUNCTION] button and press the [F1] button to return to the tone screen.

Creating a setup

A setup contains the following settings.

- The V-Piano's tone (Refer to "Customizing the V-Piano's sounds" (p. 46).)
- Tone assignments for the [TONE 1]–[TONE 4] buttons (p. 33)
- Pedal assignments (Refer to "Customizing the V-Piano's sounds" (p. 46).)
- Settings for the MIDI messages that are transmitted (Refer to "MIDI settings (5. MIDI)" (p. 84).
- Transpose setting (Refer to "Shifting the pitch (Transpose)" (p. 41)).
- "Panning Width" (p. 81) setting.

MEMO

By default, the following settings are stored as system settings; however you are free to change this so that they are stored in a setup.

- Equalizer settings (p. 35)
- Ambience settings (p. 37)

Assigning a name to a setup and saving it

If you want to use your edited settings as a setup, save them as described below.

You can assign a name to your setup.

The V-Piano lets you store 100 setups.

1. In the tone screen, press the [FUNCTION] button to turn Function on.

The [FUNCTION] button will light.

2. Press the [F4 (UTILITY)] button.

3. The utility screen will appear.

Use the [F3 (▲)] button, [F4 (▼)] button, or [VALUE] dial to select "11. Setup Write."



4. Press the [ENTER] button or the [F1 (ENTER)] button.

5. In the Setup Write screen, turn the [VALUE] dial to select the write-destination setup number.



MEMO

Setup number 001 is selected automatically when you switch on the V-Piano's power. If you store your favorite tone and settings in setup number 001, you'll be able to immediately start playing that sound and those settings as soon as you power up the V-Piano.

6. Assign a name to your setup. Press the [F2 (RENAME)] button.



- The [VALUE] dial changes the character.
- The [F1 (INSERT)] button inserts a blank space.
- The [F2 (DELETE)] button deletes the character at the cursor location.
- The [F3] button moves the cursor one character to the left.
- The [F4] button moves the cursor one character to the right.

7. When you've assigned the name, press the [ENTER] button or the [EXIT] button to return to the previous screen.

8. Press the [F4 (EXECUTE)] button.

9. A confirmation screen will appear.

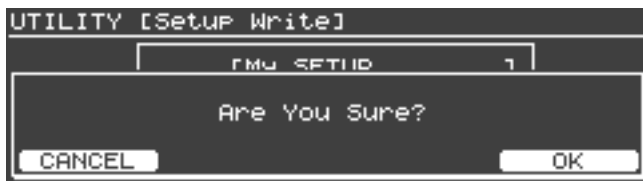

To save the setup, press the [F4 (OK)] button.

NOTE

The screen will indicate "Executing..." while the data is being saved. Never turn off the power while this indication is shown.

If you decide not to save the setup, press the [F1 (CANCEL)] button or the [EXIT] button.

10. When the setup has been saved, you will return to the utility screen.

Assigning favorite setups to the buttons

You can assign frequently used setups to the [TONE 1]–[TONE 4] buttons. This allows you to instantly access a desired setup.

1. Hold down the [FUNCTION] button and press the [F1] button.



2. The currently recalled setup number is shown.

3. Press the tone button ([TONE 1]–[TONE 4] button) to which you want to assign a setup.

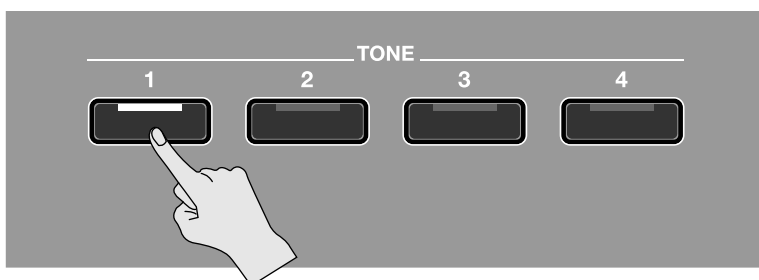

4. Turn the [VALUE] dial to select the setup that you want to assign to the specified tone button.



5. Press and hold that tone button for approximately one second.

The currently recalled setup will be assigned to that tone button.

6. Once again hold down the [FUNCTION] button and press the [F1] button to return to the tone screen.

Recalling a setup you assigned to a button

1. Hold down the [FUNCTION] button and press the [F1] button to access the setup select screen.

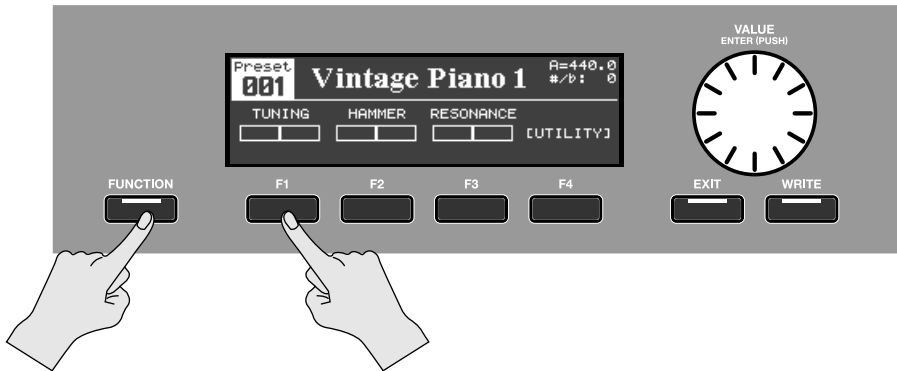

2. Press one of the [TONE 1]–[TONE 4] buttons.
The setup assigned to that tone button will be recalled.

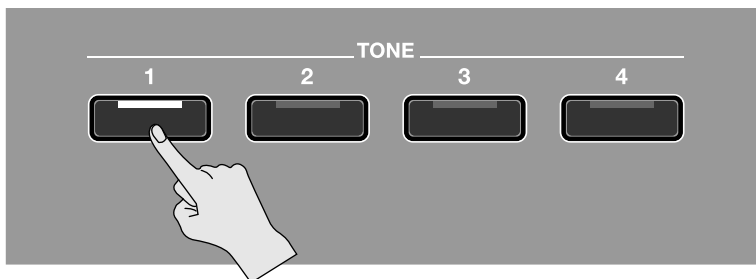

3. Once again hold down the [FUNCTION] button and press the [F1] button to return to the tone screen.

Playing songs and recording your performances

The V-Piano can play back SMF music data, audio data, and songs from a CD.

You can also play along with SMF music data and record the combined performance.

MEMO

If you want to connect a CD drive (sold separately: CD-01A) and play back songs from a CD, refer to the CD drive's owner's manual.

About the song screen

If SMF music data is selected



If audio data is selected



1. Tempo

If SMF music data is selected, this indicates the tempo.

If audio data is selected, this indicates the playback speed as a percentage.

2. Media on which the song is saved

3. Song number

If Function is off, you can use the [VALUE] dial to select a song.

4. Song name (file name)

If audio data is selected, an icon indicating the file format is shown above the song name (file name).

 : WAV format

 : MP3 format

5. Measure indication

If SMF music data is selected, this indicates the currently playing measure number.

If audio data is selected, this indicates the playback time (minutes' seconds").

[F1]–[F4] button operations

If Function is off

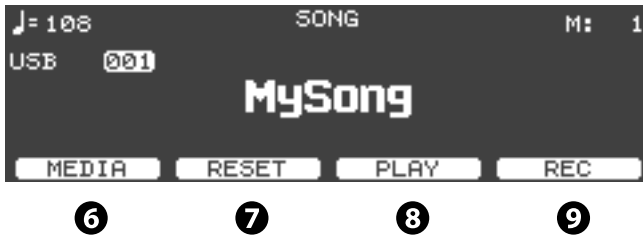

6. [F1 (MEDIA)] button

Switches the media that contains the songs.

INT: The V-Piano's internal memory

USB: USB memory or CD drive connected to the USB memory connector

7. [F2 (RESET)] button

Moves the playback position of the selected song to the beginning of the song.

8. [F3 (PLAY)] button

Plays the selected song. While the song is playing, this button pauses the song.

9. [F4 (REC)] button

Records your performance (p. 70).

If Function is on

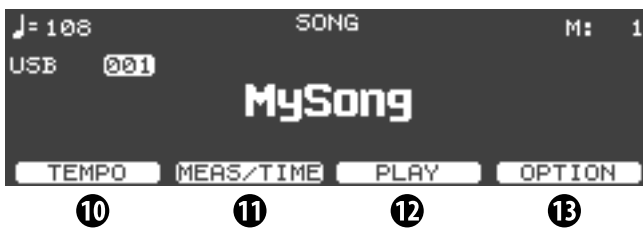

10. [F1 (TEMPO)] button

Pressing this button lets you use the [VALUE] dial to change the playback tempo.

- Tempo adjustment range for SMF music data: 10–500
- Playback speed adjustment range for audio data: -25–+25 (%)

11. [F2 (MEAS/TIME)] button

Pressing this button lets you use the [VALUE] dial to change the playback position.

12. [F3 (PLAY)] button

Plays the selected song. While the song is playing, this button pauses the song.

13. [F4 (OPTION)] button

Displays a menu that allows you to make settings, such as those for the metronome (p. 74).

Playing a song

Opening the Song screen

1. In the tone screen, press the [FUNCTION] button to turn Function on.

The [FUNCTION] button will light.



2. Press the [F4 (UTILITY)] button.



3. Use the [F3 (▲)] button, the [F4 (▼)] button, or the [VALUE] dial to select "10. Song."

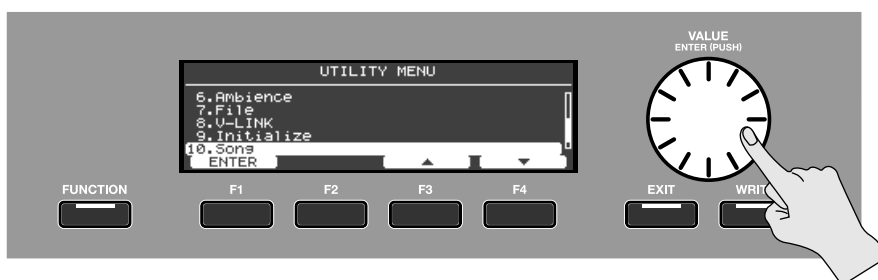

4. Press the [ENTER] button or the [F1 (ENTER)] button.

5. The song screen will appear.

MEMO

The function of accessing the song screen can be assigned to one of the [F1]–[F3] buttons. For details, refer to "Assigning functions to the [F1]–[F3] buttons" (p. 43).

Selecting a song

1. In the song screen, press the [F1 (MEDIA)] button to select the media on which the desired song is saved.

If the [F1 (MEDIA)] button is not shown, check whether the [FUNCTION] button is turned off.

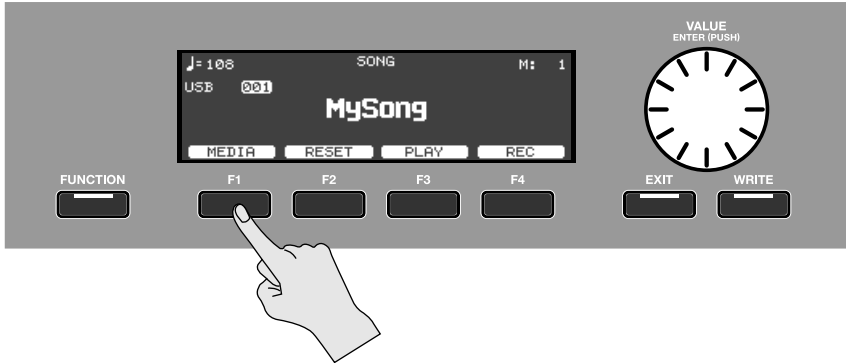

Indication	Media on which the song is saved
INT	Play songs saved in the V-Piano's internal memory
USB	Play songs saved on a device connected to the USB memory connector

2. Turn the [VALUE] dial to select a song.



To select songs in a folder

1. Use the [VALUE] dial to select the folder.

An icon will appear.



2. Press the [ENTER] button.

The songs in that folder will appear.

3. Use the [VALUE] dial to select a song.

To exit that folder, use the [VALUE] dial to select "Up" and then press the [ENTER] button.



If a single folder contains more than 500 files or folders, some of the files or folders might not be shown.

If the following screen appears

A screen like the one shown below will appear if you attempt to select a different song without saving the previously-recorded performance.

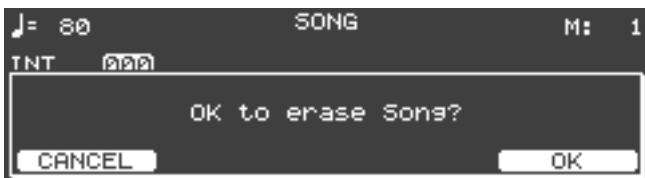

If you press the [F4 (OK)] button, the previously recorded performance will be erased.

If you don't want to lose the previously recorded performance, press the [F1 (CANCEL)] button to return to the previous screen, and save your performance (p. 73).

Playing and stopping the song

1. Press the [F3 (PLAY)] button.

The song will start playing, and the playback position indication will advance.



2. To stop the song, press the [F3 (STOP)] button.

Recording your performance

You can record your own performance on the V-Piano.

1. In the song screen, choose song number 000 (song name: New Song).

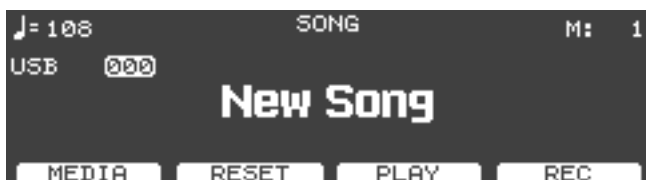

2. If you want the metronome to sound while you're recording, turn Function on, and press the [F4 (OPTION)] button.

The option menu will appear.

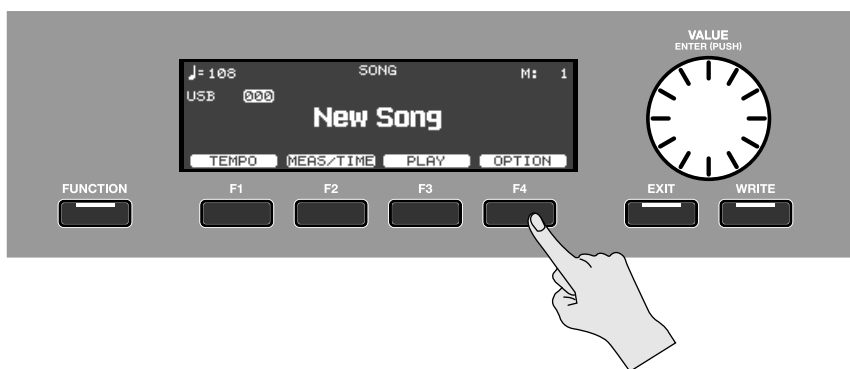

- In the option menu, use the [F3 (▲)] button or the [F4 (▼)] button to select a metronome parameter.
- Use the [VALUE] dial to change the setting of the selected parameter.

Parameter	Description
Metronome Switch	Turns the metronome on/off.
Metronome Volume	Adjusts the metronome volume.
Beat	Specifies the time signature.

3. When you've finished making metronome settings, press the [EXIT] button to return to the song screen.
4. In the song screen, turn Function on, press the [F1 (TEMPO)] button, and turn the [VALUE] dial to adjust the metronome tempo.

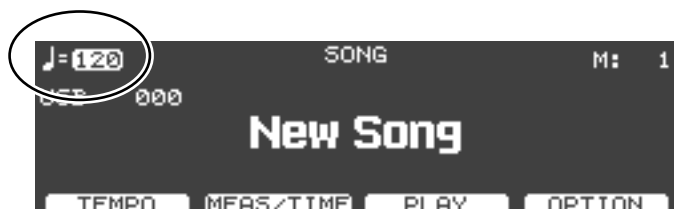

5. Now you're ready to record. In the song screen, turn Function off, and press the [F4 (REC)] button.

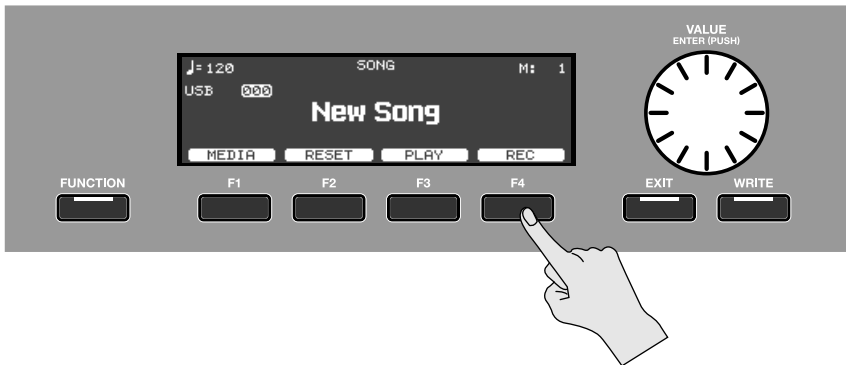

The [F3] button indication will change to [F3 (REC START)], and the V-Piano will enter recording-standby mode.



If the following screen appears

If you press the [F4 (REC)] button when a song is selected, a screen like the following will appear.

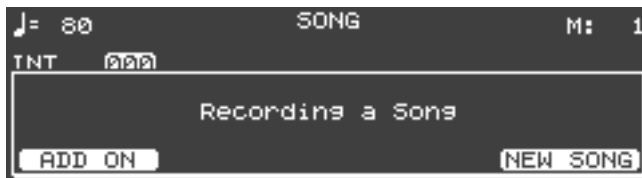

If you want to layer an additional performance onto the selected song, press the [F1 (ADD ON)] button.

If you want to record a new song (rather than layering onto an existing song), press the [F4 (NEW SONG)] button.

If the following screen appears

If you attempt to select a different song without saving the previously recorded performance, a screen like the following will appear.

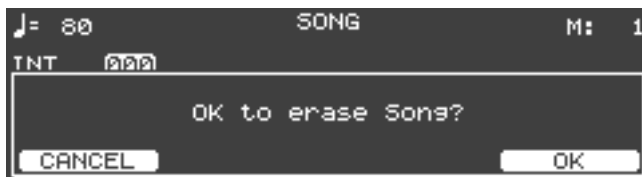

If you press the [F4 (OK)] button the previously recorded performance will be erased.

If you don't want to erase the previously recorded performance, press the [F1 (CANCEL)] button to return to the previous screen, and save your performance (p. 73).

- 6. Recording will begin when you begin playing from recording-standby mode or when you press the [F3 (REC START)] button.**



To exit recording-standby mode and stop, press the [F4 (REC)] button.

- 7. When you're finished recording, press the [F3 (STOP)] button.**

You will return to the song screen.

Saving your recorded performance

The performance you recorded will be erased when you power-off the V-Piano.
If you want to keep your performance, save it to a file as described below.

1. In the song screen, turn Function on and press the [F4 (OPTION)] button.
2. From the menu, choose "Save" and press the [ENTER] button.



The Save SONG File screen will appear.

3. Select the media on which you want to save the song file.

In the Save SONG File screen, press the [F1 (MEDIA)] button to select the store-destination media.



Setting	Store-destination
INT	The V-Piano's internal memory
USB	USB memory connected to the USB memory connector

4. Specify a name for the song file. Press the [F2 (RENAME)] button.



- The [VALUE] dial changes the character.
- The [F1 (INSERT)] button inserts a blank space.
- The [F2 (DELETE)] button deletes the character at the cursor location.
- The [F3] button moves the cursor one character to the left.
- The [F4] button moves the cursor one character to the right.

When you've assigned the name, press the [ENTER] button or the [EXIT] button to return to the previous screen.

5. When you've finished entering the file name, press the [F4 (EXECUTE)] button to start saving the song.

NOTE

The screen will indicate "Executing..." while the data is being saved. Never turn off the power while this indication is shown.

MEMO

If an identically named file already exists, a confirmation screen will ask "File Exists Overwrite OK?" If you want to overwrite the existing song file, press the [F4 (OK)] button. If you want to save the song under a different file name, press the [F1 (CANCEL)] button.

6. When the song has been saved, press the [EXIT] button to return to the previous screen.

Option settings in the song screen

In the song screen you can turn Function on and press the [F4 (OPTION)] button to access the option menu screen, where you can make settings such as for the metronome.



- Use the [F3 (▲)] button or [F4 (▼)] button to select a parameter.
- Use the [VALUE] dial to edit the value.

Parameter	Description	Range	Default setting
Save	Saves the recorded song. For details, refer to "Saving your recorded performance" (p. 73).	—	—
Metronome Switch	Turns the metronome on/off.	OFF, ON	OFF
Metronome Volume	Adjusts the metronome volume.	0–10	5
Beat	Specifies the time signature.	2/2, 0/4, 2/4, 3/4, 4/4, 5/4, 6/4, 7/4, 3/8, 6/8, 9/8, 12/8	4/4
Play Mode	Specifies whether to play a single song (ONE SONG) or all songs (ALL SONG).	ONE SONG, ALL SONG	ONE SONG
Transpose	Transposes the playback. You can specify this for both SMF music data and audio data.	-6→+5 (semitone)	0
Center Cancel	Minimizes the vocal portion of the audio data playback (Center Cancel). • For some songs, the vocal may not be entirely eliminated.	OFF, ON	OFF
MIDI Output	Specifies whether MIDI messages will be transmitted via MIDI (ON) or not transmitted (OFF) when playing back SMF music data.	OFF, ON	ON

Types of audio data that the V-Piano can play

WAV format

Sampling frequency	44.1 kHz
Bit depth	16-bit
File extension	.wav

MP3 format

Format	MPEG-1 audio layer 3
Sampling frequency	44.1 kHz
Bit rate	32/40/48/56/64/80/96/112/128/160/192/224/256/320kbps, VBR (Variable Bit Rate)
File extension	.mp3

Detailed settings for various functions (Utility screen)

How to make settings

1. From the Tone screen, press the [FUNCTION] button to turn Function on.

The [FUNCTION] button will light.



2. Press the [F4 (UTILITY)] button.



3. The Utility screen will appear.

Use the [F3 (▲)] / [F4 (▼)] buttons or the [VALUE] dial to select a group.



4. Press the [ENTER] button or the [F1 (ENTER)] button to see the parameters in that group.

5. Use the [F3 (▲)] / [F4 (▼)] buttons to select a parameter within the group.



6. Turn the [VALUE] dial to adjust the value.

You can press the [F2 (RESET)] button to return to the initial value.

NOTE

Simply changing a value does not cause the change to be memorized. You must execute the Write operation to store your change in the appropriate memory location for that parameter. Refer to "Parameters That Can Be Set" (p. 78) for the memory locations and procedure for each parameter.

7. Press the [EXIT] button to return to the previous screen.

Saving the System parameters

With the Utility screen "1. System" shown, press the [WRITE] button; the parameters will be saved to system memory.

NOTE

You cannot save just an individual parameter by itself. When you save the System parameters, all the parameters you modified will be saved in a single operation.

1. From the Tone screen, press the [FUNCTION] button to turn Function on.

The [FUNCTION] button will light.

2. Press the [F4 (UTILITY)] button.

3. Use the [F3 (▲)] or [F4 (▼)] buttons to select "1. System."



4. Press the [ENTER] button or the [F1 (ENTER)] button to access the system setting screen.

5. Press the [WRITE] button.



6. A confirmation message will appear. To save the system parameter, press the [F4 (OK)] button.

All of the System parameters you edited will be saved to System memory.

If you decide to cancel without saving, press the [F1 (CANCEL)] button.

Parameters That Can Be Set

1. System Group

<u>Parameter</u>	<u>Refer to...</u>	<u>Stored in...</u>
Master Tune	p. 80	SYSTEM
Temperament	p. 80	SYSTEM
Temperament Key	p. 80	SYSTEM
Master Volume	p. 80	SYSTEM
Output Gain	p. 80	SYSTEM
GM2/WAV Volume	p. 80	SYSTEM
EQ Mode	p. 80	SYSTEM
Information Type	p. 80	SYSTEM
USB Driver	p. 80	SYSTEM
USB Memory Mode	p. 80	SYSTEM
V-Piano Output Mode	p. 80	SYSTEM
GM2/WAV Output Mode	p. 80	SYSTEM
Output Balance	p. 80	SYSTEM
Line Out Mode	p. 81	SYSTEM
Sound Perspective	p. 81	SYSTEM
Headphone Mode	p. 81	SYSTEM
Panning Width	p. 81	SETUP
Tone Button Mode	p. 81	not stored
Tx Edit	p. 81	SYSTEM
Local Switch	p. 81	not stored

2. Tone Parameter Group

<u>Parameter</u>	<u>Refer to...</u>	<u>Stored in...</u>
Sound Lift	p. 48	TONE
Soft Pedal Sense	p. 48	TONE
String Resonance	p. 48	TONE
Damper Resonance	p. 48	TONE
Soundboard Resonance	p. 48	TONE
Key Off Resonance	p. 48	TONE
Unison Tune	p. 49	TONE
Stretch Tune	p. 49	TONE
Hammer Hardness	p. 49	TONE
Cross Resonance	p. 49	TONE
Decay Time	p. 49	TONE
Tone Color	p. 50	TONE
Damping Time	p. 50	TONE
Damper Noise Level	p. 50	TONE
Tone EQ	p. 82	TONE

3. Key Touch Group

<u>Parameter</u>	<u>Refer to...</u>	<u>Stored in...</u>
Key Touch	p. 83	SYSTEM
Key Touch Offset	p. 83	SYSTEM
Velocity	p. 83	SYSTEM
Velocity Delay Sens	p. 83	SYSTEM
Velocity Key Follow Sens	p. 83	SYSTEM
Piano Emotion	p. 83	SYSTEM

4. Pedal Group

<u>Parameter</u>	<u>Refer to...</u>	<u>Stored in...</u>
Piano Pedal Mode	p. 84	SYSTEM
Center Pedal Assign	p. 84	SYSTEM/SETUP
Center Pedal Min	p. 84	SYSTEM/SETUP
Center Pedal Max	p. 84	SYSTEM/SETUP
Left Pedal Assign	p. 84	SYSTEM/SETUP
Left Pedal Min	p. 84	SYSTEM/SETUP
Left Pedal Max	p. 84	SYSTEM/SETUP
Foot Controllers Mode	p. 84	SYSTEM
FC2 Assign	p. 84	SYSTEM/SETUP
FC2 Min	p. 84	SYSTEM/SETUP
FC2 Max	p. 84	SYSTEM/SETUP
FC1 Assign	p. 84	SYSTEM/SETUP
FC1 Min	p. 84	SYSTEM/SETUP
FC1 Max	p. 84	SYSTEM/SETUP

5. MIDI Group

<u>Parameter</u>	<u>Refer to...</u>	<u>Stored in...</u>
MIDI Tx Channel	p. 86	SETUP
V-Piano Rx Channel	p. 86	SYSTEM
Tx Bank Select (MSB)	p. 86	SETUP
Tx Bank Select (LSB)	p. 86	SETUP
Tx Program Change	p. 86	SETUP

6. Ambience Group

<u>Parameter</u>	<u>Refer to...</u>	<u>Stored in...</u>
Ambience Mode	p. 86	SYSTEM
Ambience Type	p. 86	SYSTEM/SETUP
Ambience Level	p. 86	SYSTEM/SETUP

7. File Group

<u>Parameter</u>	<u>Refer to...</u>
Save SETUP File	p. 87
Load SETUP File	p. 89
Delete SETUP File	p. 90
Copy SETUP File	p. 91
Save SONG File	p. 92
Delete SONG File	p. 93
Copy SONG File	p. 94
Format	p. 95

8 V-LINK Group

<u>Parameter</u>	<u>Refer to...</u>	<u>Stored in...</u>
V-LINK Switch	p. 97	SYSTEM
V-LINK Mode	p. 97	SYSTEM
V-LINK Tx Channel	p. 97	SYSTEM
Key Range	p. 97	SYSTEM
Lowest No.	p. 97	SYSTEM
Local Switch	p. 97	SYSTEM

9. Initialize Group

<u>Parameter</u>	<u>Refer to...</u>
Delete User Tone	p. 98
Factory Reset All	p. 99

10. SONG Group

Refer to "Playing songs and recording your performances" (p. 64).

11 Setup Write Group

Refer to "Assigning a name to a setup and saving it" (p. 60).

Saving parameters

Different parameters are saved in different locations (Tone, Setup, or System). Tones and the parameters saved in a Setup are not memorized until you save them to a Tone or to a Setup.

Saving parameters stored in System memory

Refer to "Saving the System parameters" (p. 77).

Saving parameters stored in a Setup

Refer to "Assigning a name to a setup and saving it" (p. 60).

Saving parameters stored in a Tone

Refer to "Saving a tone you've customized" (p. 51).

System settings (1. System)

**NOTE**

The following parameters are not saved in System memory or Setup memory. They will return to the default settings when you power-off the V-Piano.

Tone Button Mode

Local Switch

NOTE

Leave the USB Driver at the GENERIC setting. If you change this to ORIGINAL, you'll need dedicated drive software in order to connect the V-Piano to your computer. For more about the dedicated driver software, refer to the Roland website.

Roland website: <http://www.roland.com/>

Parameter	Description	Value	Default Value
Master Tune	Changes the reference pitch of the V-Piano.	415.3–466.2 (Hz)	440.0 (Hz)
Temperament	Changes the temperament (tuning method).	EQUAL, JUST MAJOR, JUST MINOR, PYTHAGOREAN, KIRNBERGER, MEANTONE, WERCKMEISTER, ARABIC	EQUAL
Temperament Key	Specifies the tonic of the temperament (tuning method).	C, C#, D, Eb, E, F, F#, G, G#, A, Bb, B	C
Master Volume	Adjusts the volume of the entire V-Piano.	0–127	127
Output Gain	Sets the overall volume.	-12–+12 (dB)	0 (dB)
GM2/WAV Volume	Adjusts the playback volume for SMF music data or audio data.	0–127	127
EQ Mode	Equalizer settings can be saved within each setup. When you switch setups, this setting specifies whether the equalizer settings will change to the settings saved in that setup (SETUP) or will not change (SYSTEM).	SETUP, SYSTEM	SETUP
Information Type	Specifies the parameters shown in the Tone screen. OFF: No display BASIC: <ul style="list-style-type: none"> Master Tune (p. 80) Transposition amount (p. 41) Tone number (only when selecting a Setup) (p. 31) AMBIENCE: <ul style="list-style-type: none"> Ambience Mode (p. 86) Ambience Type (p. 86) Ambience Level (p. 86) PEDAL: <ul style="list-style-type: none"> Piano Pedal Mode (p. 84) Center Pedal Assign (p. 84) Left Pedal Assign (p. 84) 	OFF, BASIC, AMBIENCE, PEDAL	BASIC
USB Driver	Specifies the USB driver to use when you connect your computer via the USB MIDI connector. Leave the USB Driver at the GENERIC setting.	ORIGINAL, GENERIC	GENERIC
USB Memory Mode	In certain cases, data reading may be slow or unsuccessful when you connect USB memory to the USB memory connector. If so, you may be able to solve the problem by switching this USB memory setting.	MODE1, MODE2	MODE2
V-Piano Output Mode	Specifies the output(s) from which the V-Piano's sound will be sent (OUTPUT A jacks and/or OUTPUT B jacks).	A, B, A+B	A+B
GM2/WAV Output Mode	Specifies the output(s) from which SMF music data or audio data playback will be sent (OUTPUT A jacks and/or OUTPUT B jacks).	A, B, A+B	A+B
Output Balance	Specifies the volume balance of the OUTPUT A jacks and OUTPUT B jacks.	A:100 - B:0– A:100 - B:100– A:0 - B:100	A:100 - B:100

Parameter	Description	Value	Default Value
Line Out Mode	<p>Specifies whether the V-Piano's sound will be output in monaural or in stereo.</p> <p>To allow the V-Piano to produce the highest-quality piano sound, it was designed with stereo output in mind. The tonal character will be affected if you output only one channel or if you mix the left and right channels for monaural output.</p> <p>If you want to output the V-Piano in monaural, choose the MONO setting. With the MONO setting, the OUTPUT A jacks L/1 and R/2 will output the same sound.</p>	STEREO, MONO	STEREO
Sound Perspective	<p>Specifies the V-Piano's multi-channel output setting. For details on speaker placement, refer to "Connecting multi-channel speakers" (p. 21).</p> <p>A:DRY B:AMBIENCE: This setting produces spacious reverberation. The OUTPUT A jacks will output the sound of the V-Piano with no ambience applied, and the OUTPUT B jacks will output only the ambience sound.</p> <p>GRAND AMBIENCE: The four-channel multi-output is used to produce the sense of depth distinctive of a grand piano.</p>	OFF, A:DRY B:AMBIENCE, GRAND AMBIENCE	OFF
Headphone Mode	Specifies the output to the headphone jack. This allows you to output only the sound of the OUTPUT A jacks or the OUTPUT B jacks to the headphones.	A, B, ALL	ALL
Panning Width	<p>Specifies how panning is affected by the keyboard region.</p> <p>With higher values, the lower keys are panned toward the left, while higher keys are panned toward the right.</p> <p>Lower values will reduce the panning difference between lower and higher keys.</p>	0–100%	100%
Tone Button Mode	<p>Specifies whether the tone buttons ([TONE 1] button –[TONE 4] button) will select tones (TONE) or setups (SETUP).</p> <p>This parameter will return to the default value when you power-off the V-Piano.</p>	TONE, SETUP	TONE
Tx Edit	When you edit the tone, this setting specifies whether your edits will be transmitted via MIDI as system exclusive messages (ON) or not transmitted (OFF).	OFF, ON	ON
Local Switch	Local Switch allows the performance data from the keyboard to be sent to the sound generator, or breaks this connection. If the Local Switch setting is turned off, performance data from the keyboard will not be sent to the sound generator.	OFF, ON	ON

Tone parameter settings (2. Tone Parameter)

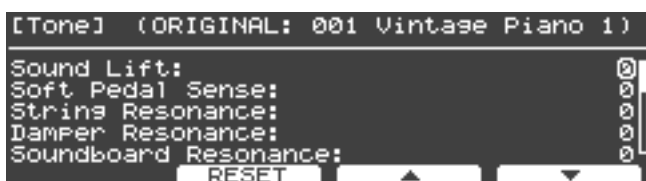

The parameters in this group are the same as the parameters that you can edit in the Tone screen.
For an explanation of the parameters and their values, refer to “Customizing the V-Piano’s sounds” (p. 48).

ORIGINAL

This screen shows the name of the preset tone that was the basis of the customized tone.

* You cannot change the preset tone that was the basis of the customized tone.

Tone EQ

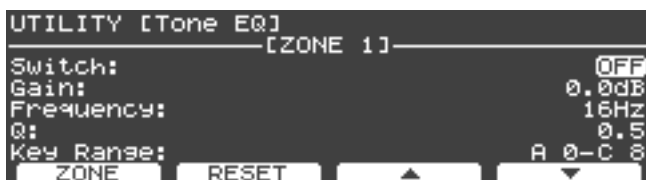

Each tone allows you to apply an equalizer to specific regions (“Zones”). This is called the Tone EQ. For each tone you can specify four Zones, and make different settings for each Zone.

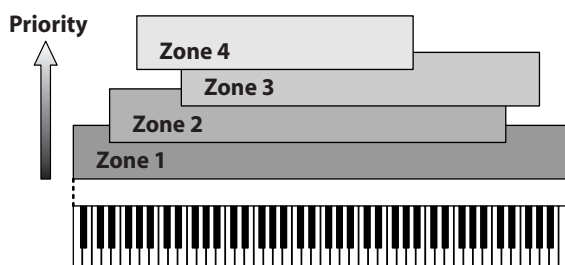

Of the four Zones, the settings of Zone 4 will take priority.

Each Zone has the following parameters.

Parameter	Value	Description
Switch	OFF, ON	Turns this ZONE’s EQ on/off.
Gain	-12~+12 dB	Adjusts the gain.
Frequency	16~16000 Hz	Adjusts the center frequency.
Q	0.5, 1.0, 2.0, 4.0, 8.0	Adjusts the bandwidth. Higher values will narrow the frequency range.
Key Range	A0-C8	Sets the key range of this ZONE.

MEMO

Press the [F1 (ZONE)] button to switch between Zones.

Keyboard touch settings (3. Key Touch)



Parameter	Description	Value	Default Value
Key Touch	Adjusts the touch sensitivity of the keyboard by changing the way in which the sound responds to your keyboard playing dynamics. SUPER LIGHT is the lightest setting, and SUPER HEAVY is the heaviest.	SUPER LIGHT, LIGHT, MEDIUM, HEAVY, SUPER HEAVY	MEDIUM
Key Touch Offset	Adjusts the touch sensitivity of the keyboard with greater precision than the Key Touch setting.	-10--+9	0
Velocity	Specifies that notes will sound at a fixed volume regardless of the strength (velocity) with which you play the keyboard. If you want the volume to change in response to your keyboard playing dynamics, choose the REAL setting.	REAL, 1-127	REAL
Velocity Delay Sens	Specifies the time from the instant you play a key until sound is heard. With negative (-) values, the note will be delayed longer if you play more strongly. With positive (+) values, the note will be delayed longer if you play more softly.	-63--+63	0
Velocity Key Follow Sens	Specifies how the keyboard touch will vary as you play in different regions of the keyboard. With higher values, higher regions of the keyboard will feel heavier and lower regions will feel lighter.	-63--+63	0
Piano Emotion	Increasing this value will produce an emphasized sense of attack when you play staccato.	0-127	20

MEMO

The Key Touch and Key Touch Offset settings are linked.

Pedal settings (4. Pedal)

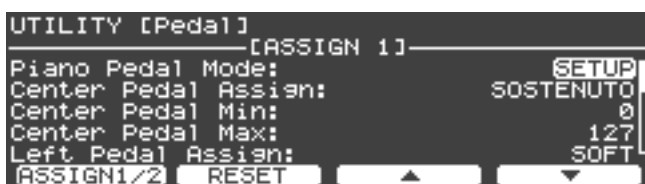

Here you can make settings for the piano pedals and for the pedals connected to the PEDAL FC1 jack / FC2 jack.

Parameter	Description	Value	Default Value
Piano Pedal Mode	Piano pedal settings can be saved within each setup (p. 59). When you switch setups, this setting specifies whether the piano pedal settings will change to the settings saved in that setup (SETUP) or will not change (SYSTEM).	SETUP, SYSTEM	SETUP
Center Pedal Assign	Specifies the function that will be controlled by the center piano pedal.	Refer to "Functions that can be assigned to a pedal" (p. 85).	SOSTENUTO
Center Pedal Min	Specifies the value sent when the center piano pedal is released.	(Range of values for the assigned function)	(Minimum value for the assigned function)
Center Pedal Max	Specifies the value sent when the center piano pedal is fully depressed.		(Maximum value for the assigned function)
Left Pedal Assign	Specifies the function that will be controlled by the left piano pedal.	Refer to "Functions that can be assigned to a pedal" (p. 85).	SOFT
Left Pedal Min	Specifies the value sent when the left piano pedal is released.	(Range of values for the assigned function)	(Minimum value for the assigned function)
Left Pedal Max	Specifies the value sent when the left piano pedal is fully depressed.		(Maximum value for the assigned function)
Foot Controllers Mode	Settings for the pedals connected to the FC1 jack and FC2 jack are saved within each setup (p. 59). When you switch setups, this setting specifies whether these pedal settings will change to the settings saved in that setup (SETUP) or will not change (SYSTEM).	SETUP, SYSTEM	SETUP
FC2 Assign	Specifies the function that will be controlled by the pedal connected to the FC2 jack.	Refer to "Functions that can be assigned to a pedal" (p. 85).	SOSTENUTO
FC2 Min	Specifies the value sent when the pedal connected to the FC2 jack is released.	(Range of values for the assigned function)	(Minimum value for the assigned function)
FC2 Max	Specifies the value sent when the pedal connected to the FC2 jack is fully depressed.		(Maximum value for the assigned function)
FC1 Assign	Specifies the function that will be controlled by the pedal connected to the FC1 jack.	Refer to "Functions that can be assigned to a pedal" (p. 85).	SOFT
FC1 Min	Specifies the value sent when the pedal connected to the FC1 jack is released.	(Range of values for the assigned function)	(Minimum value for the assigned function)
FC1 Max	Specifies the value sent when the pedal connected to the FC1 jack is fully depressed.		(Maximum value for the assigned function)

NOTE

You cannot change the settings for the right piano pedal or the pedal connected to the DAMPER jack. These pedals will always operate as damper pedals.

Functions that can be assigned to a pedal

Value	Function
OFF	No assign
SOFT	Operate as soft pedal
SOSTENUTO	Operate as sostenuto pedal
MIDI OUT SW	Turn on/off MIDI output of performance data
SONG PLAY/STOP	Play/stop the selected song
TRANPOSE SW	Turn transpose on/off
SONG RESET	Move the playback position to the beginning of the song
MASTER VOLUME	Adjust the volume of the entire V-Piano
EXPRESSION	The V-Piano's volume
AMBIENCE LEVEL	Adjust the ambience
SOUND LIFT	Adjust the tone parameter (p. 48)
STRING RESONANCE	
DAMPER RESONANCE	
SOUNDBOARD RESO	
KEY OFF RESONANCE	
UNISON TUNE	
HAMMER HARDNESS	
CROSS RESONANCE	
DECAY TIME	
STONE COLOR	
DAMPING TIME	
DAMPER NOISE LEVEL	
SETUP UP	
SETUP DOWN	Recall the preceding setup

NOTE

SETUP UP and SETUP DOWN can be selected only if the pedal settings are the settings stored in system memory.

MEMO

"SOUNDBOARD RESO" is an abbreviation of "Soundboard Resonance."

MIDI settings (5. MIDI)



Parameter	Description	Value	Default Value
MIDI Tx Channel	Specifies the MIDI channel on which the V-Piano's performance data is transmitted via MIDI. If you want to use the V-Piano's performance data to play an external MIDI device, set the V-Piano's transmit channel to match the receive channel of the external MIDI device.	1–16	1
V-Piano Rx Channel	Specifies the V-Piano's receive channel. If you want to use MIDI data from an external MIDI device to play the V-Piano's sounds, set the V-Piano's receive channel to match the transmit channel of the external MIDI device.	OFF, 1–16	1
Tx Bank Select (MSB)	Specifies the Bank Select MSB that is transmitted when a setup is recalled.	OFF, 0–127	OFF
Tx Bank Select (LSB)	Specifies the Bank Select LSB that is transmitted when a setup is recalled.	OFF, 0–127	OFF
Tx Program Change	Specifies the Program Change that is transmitted when a setup is recalled.	OFF, 1–128	OFF

NOTE

The V-Piano Rx Channel setting is stored in system memory. It cannot be individually stored in each setup.

Ambience settings (6. Ambience)



Parameter	Description	Value	Default Value
Ambience Mode	Ambience settings can be individually stored in each setup. When you switch setups, this setting specifies whether the ambience settings will change to the settings saved in that setup (SETUP) or will not change (SYSTEM).	SETUP, SYSTEM	SYSTEM
Ambience Type	Selects the type of ambience.	ROOM 1, ROOM 2, ROOM 3, STUDIO 1, STUDIO 2, STUDIO 3, CLUB 1, CLUB 2, CLUB 3, HALL 1, HALL 2, HALL 3	HALL 1
Ambience Level	Adjusts the ambience effect. This parameter is linked with the [AMBIENCE] Knob.	0–127	40

File management (7. File)



What is a setup file?

A “setup file” contains the V-Piano’s 100 user setups, 100 user tones, and system settings, all in a single file.

This setup file can be saved to internal memory or to USB memory (separately sold) connected to the USB memory connector.

About song files

SMF music files stored in USB memory can be copied to the V-Piano’s internal memory.

A performance you’ve recorded on the V-Piano can also be saved as a song file to internal memory or to USB memory.

NOTE

Audio data cannot be copied to internal memory.

Saving a setup file (Save SETUP File)

Here’s how to save a setup file to internal memory or to USB memory (separately sold) connected to the USB memory connector.

- 1. In the File screen, turn the [VALUE] dial to select “Save SETUP File,” and then press the [ENTER] button or the [F1 (ENTER)] button.**



- 2. Choose the media to which you want to save the setup file.**

In the Save SETUP File screen, press the [F1 (MEDIA)] button to select the save-destination media.

Value	Media
INT	V-Piano’s internal memory
USB	USB memory connected to the USB memory connector

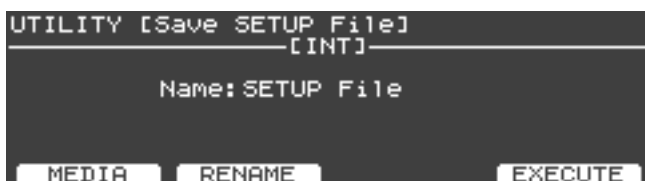

3. Assign a name to the setup file. Press the [F2 (RENAME)] button.



- Use the [VALUE] dial to change the character.
- Press the [F1 (INSERT)] button to insert a space.
- Press the [F2 (DELETE)] button to delete the character at the cursor location.
- Press the [F3] button to move the cursor one character to the left.
- Press the [F4] button to move the cursor one character to the right.

When you've specified the name, press the [ENTER] button or the [EXIT] button to return to the previous screen.

4. When you've finished entering the file name, press the [F4 (EXECUTE)] button to start saving the file.

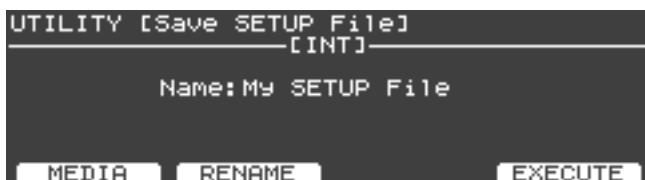

NOTE

The screen will indicate "Executing..." while the file is being saved. Never turn off the power while this screen is shown.



MEMO

If a file of the same name already exists, the confirmation message "File Exists Overwrite OK?" appears. If you want to overwrite the existing setup file, press the [F4 (OK)] button. If you want to re-save the file with a different name, press the [F1 (CANCEL)] button.

5. When the file has been saved, press the [EXIT] button to return to the previous screen.

Loading a setup file (Load SETUP File)

Here's how to load a previously saved setup file.

When you load a setup file, the V-Piano's user setups and user tones will be overwritten and lost.

If there are important settings that you want to keep, save them to memory before you proceed.

1. In the File screen, turn the [VALUE] dial to select "Load SETUP File," and then press the [ENTER] button or the [F1 (ENTER)] button.



2. Press the [F1 (MEDIA)] button to specify the media that contains the setup file that was saved.

Value	Media
INT	V-Piano's internal memory
USB	USB memory connected to the USB memory connector

3. Turn the [VALUE] dial to select the setup file that you want to load.



4. If you also want to load the system setting parameters from the file, press the [F2 (System)] button.

A symbol will appear in the screen.

5. To load the file, press the [F4 (EXECUTE)] button.

6. A confirmation message will appear. To load the file, press the [F4 (OK)] button.

If you decide to cancel without loading, press the [F1 (CANCEL)] button.



NOTE

Never turn off the power while a file is being loaded.

MEMO

Files whose name includes characters that cannot be displayed by the V-Piano are shown as "?".

7. When the file has been loaded, press the [EXIT] button to return to the previous screen.

Deleting a setup file (Delete SETUP File)

Here's how to delete a setup file that was previously saved in the V-Piano's internal memory or in USB memory.

1. In the File screen, turn the [VALUE] dial to select "Delete SETUP File," and then press the [ENTER] button or the [F1 (ENTER)] button.

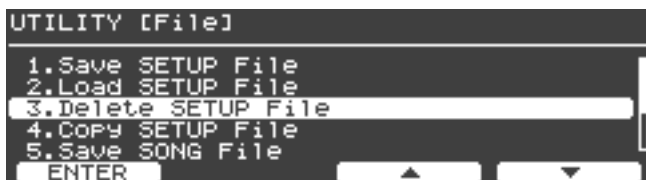

2. Press the [F1 (MEDIA)] button to specify the media that contains the setup file.

Value	Media
INT	V-Piano's internal memory
USB	USB memory connected to the USB memory connector

3. Turn the [VALUE] dial to select the setup file that you want to delete.



NOTE

If you choose "ALL," all setup files will be deleted.

4. To delete the selected file, press the [F4 (EXECUTE)] button.
5. A confirmation message will appear. To delete the file(s), press the [F4 (OK)] button.



If you decide to cancel without deleting, press the [F1 (CANCEL)] button.

NOTE

Never turn off the power while a file is being deleted.

6. When deletion is completed, press the [EXIT] button to return to the previous screen.

Copying a setup file (Copy SETUP File)

Here's how to copy a setup file from the V-Piano's internal memory to USB memory (sold separately).

You can also copy a setup file from USB memory to the V-Piano's internal memory.

1. In the File screen, turn the [VALUE] dial to select "Copy SETUP File," and press the [ENTER] button or the [F1 (ENTER)] button.



2. Press the [F1 (DEST)] button to specify how copying is to occur.

Value	Description
INT→USB	Copy from the V-Piano's internal memory to USB memory.
USB→INT	Copy from USB memory to the V-Piano's internal memory.

3. Turn the [VALUE] dial to select the setup file(s) to be copied.



NOTE

If you choose "ALL," all setup files will be copied.

4. To copy the selected file(s), press the [F4 (EXECUTE)] button.

NOTE

While files are being copied, the screen will indicate "Executing..." Never turn off the power during this time.

MEMO

If a file of the same name already exists, the confirmation message "Overwrite OK?" appears. If you want to overwrite the existing setup file, press the [F4 (OK)] button. If you want to cancel the copy, press the [F1 (CANCEL)] button.

5. When copying is completed, press the [EXIT] button to return to the previous screen.

Saving a song (Save SONG File)

Here's how a performance you recorded on the V-Piano can be saved to internal memory or to USB memory (sold separately) connected to the USB memory connector.

1. In the File screen, turn the [VALUE] dial to select "Save SONG File," and press the [ENTER] button or the [F1 (ENTER)] button.



2. Select the media on which you want to save the song file.

In the Save SONG File screen, press the [F1 (MEDIA)] button to select the save-destination media.

Value	Media
INT	V-Piano's internal memory
USB	USB memory connected to the USB memory connector

3. Assign a name to the song file. Press the [F2 (RENAME)] button.



- Use the [VALUE] dial to change the character.
- Press the [F1 (INSERT)] button to insert a space.
- Press the [F2 (DELETE)] button to delete the character at the cursor location.
- Press the [F3] button to move the cursor one character to the left.
- Press the [F4] button to move the cursor one character to the right.

When you've specified the name, press the [ENTER] button or the [EXIT] button to return to the previous screen.

4. When you've finished entering the file name, press the [F4 (EXECUTE)] button to start saving the file.



NOTE

The screen will indicate "Executing..." while the file is being saved. Never turn off the power while this screen is shown.

MEMO

If a file of the same name already exists, the confirmation message "File Exists Overwrite OK?" appears. If you want to overwrite the existing setup file, press the [F4 (OK)] button. If you want to re-save the file under a different name, press the [F1 (CANCEL)] button.

5. When the file has been saved, press the [EXIT] button to return to the previous screen.

Deleting a song (Delete SONG File)

Here's how to delete a song file from the V-Piano's internal memory or from USB memory.

1. In the File screen, turn the [VALUE] dial to select "Delete SONG File" and then press the [ENTER] button or the [F1 (ENTER)] button.



2. Press the [F1 (MEDIA)] button to specify the media that contains the song file that you want to delete.

Value	Media
INT	V-Piano's internal memory
USB	USB memory connected to the USB memory connector

3. Turn the [VALUE] dial to select the song file that you want to delete.

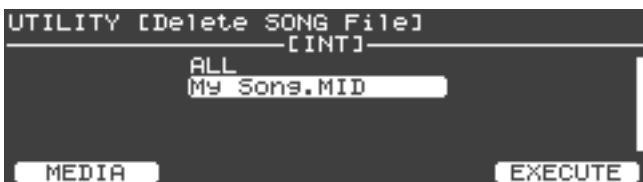

NOTE

If you select "ALL," all song files will be deleted.

4. To delete the selected file(s), press the [F4 (EXECUTE)] button.
5. A confirmation message will appear. To delete the file(s), press the [F4 (OK)] button.



If you decide to cancel without deleting, press the [F1 (CANCEL)] button.

NOTE

Never turn off the power while a file is being deleted.

6. When deletion is completed, press the [EXIT] button to return to the previous screen.

Copying a song (Copy SONG File)

Here's how a song previously saved in the V-Piano's internal memory can be copied to USB memory. A song saved on USB memory can also be copied to internal memory.

NOTE

Audio files cannot be copied to internal memory.

1. In the File screen, turn the [VALUE] dial to select "Copy SONG File" and then press the [ENTER] button or the [F1 (ENTER)] button.



2. Press the [F1 (DEST)] button to specify how copying is to occur.

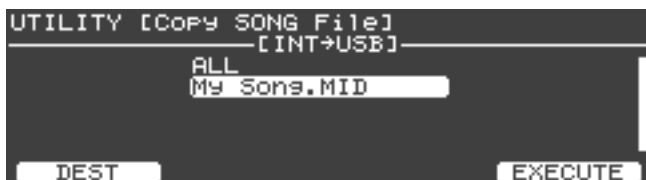

Value	Description
INT->USB	Copy from the V-Piano's internal memory to USB memory.
USB->INT	Copy from USB memory to the V-Piano's internal memory.

3. Turn the [VALUE] dial to select the song file(s) to be copied.

NOTE

If you choose "ALL," all song files will be copied.

4. To copy the selected file(s), press the [F4 (EXECUTE)] button.

NOTE

While files are being copied, the screen will indicate "Executing..." Never turn off the power during this time.

MEMO

If a file of the same name already exists, the confirmation message "Overwrite OK?" appears. If you want to overwrite the existing song file, press the [F4 (OK)] button. If you want to cancel the copy, press the [F1 (CANCEL)] button.

5. When copying is completed, press the [EXIT] button to return to the previous screen.

Formatting internal memory or USB memory (Format)

This operation will erase all data stored in internal memory or USB memory.

MEMO

When you execute this Format operation, all data stored in internal memory or USB memory will be erased. Before you proceed, make sure that internal memory or USB memory does not contain important data.

MEMO

Formatting the internal memory will erase data in the area that contains setup files and song files. User setups, user tones, and system settings will not be erased. If you want to erase this data, execute the "Factory reset (Factory Reset All)" (p. 99) operation.

MEMO

Formatting USB memory will not only erase all data in memory, it will also prepare the memory so that it can be used with the V-Piano. Before newly purchased USB memory or USB memory that has been used by a computer can be used with the V-Piano, you must first format the USB memory on the V-Piano.

1. In the File screen, turn the [VALUE] dial to select "Format," and then press the [ENTER] button or the [F1 (ENTER)] button.



2. The screen will indicate "Erases entire memory content."

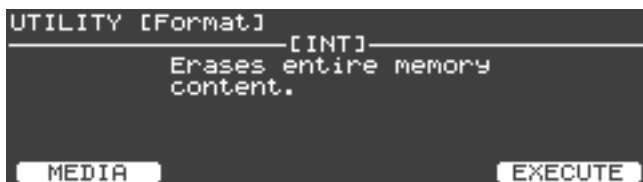

3. In the Format screen, press the [F1 (MEDIA)] button to specify the memory that you want to format.

Value	Description
INT	V-Piano's internal memory
USB	USB memory connected to the USB memory connector

4. To begin formatting, press the [F4 (EXECUTE)] button.
5. A confirmation message will appear. To begin formatting, press the [F4 (OK)] button.

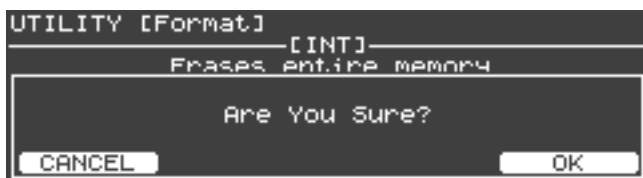

If you decide to cancel without formatting, press the [F1 (CANCEL)] button.

MEMO

The message "Executing..." is shown while formatting is being done. Never turn off the power or disconnect USB memory during this time.

6. When formatting is finished, press the [EXIT] button to return to the previous screen.

V-LINK settings (8. V-LINK)

V-LINK (**V-LINK**) is a function that provides for the play of music and visual material. By using V-LINK-compatible video equipment, visual effects can be easily linked to, and made part of the expressive elements of a performance.



For example, if you use the V-Piano in conjunction with the EDIROL P-10 VISUAL SAMPLER, you'll be able to produce synchronized music and video performances.

MEMO

In order to use V-LINK between the V-Piano and the EDIROL P-10, you'll need to make connections using a MIDI cable (sold separately).

Connection Examples

As an example, we will use a Setup in which the V-Piano is connected to the EDIROL P-10. Use a MIDI cable to connect the V-Piano's MIDI OUT connector to the MIDI IN connector of the EDIROL P-10.

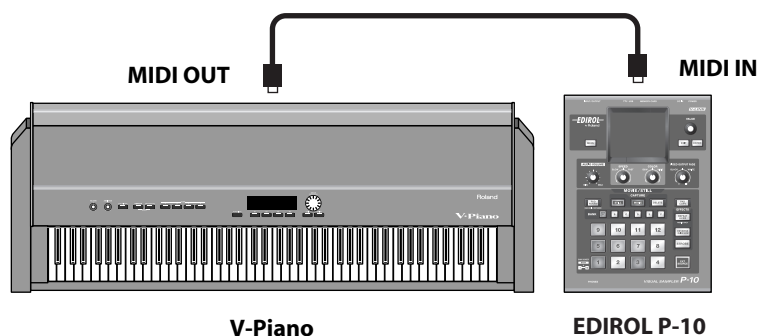

NOTE

Before connecting this unit to other devices, turn off the power to all units. This will help prevent malfunctions and/or damage to speakers or other devices.

Turning the V-LINK ON/OFF

1. Press the [V-LINK] button.

The [V-LINK] button will light, and the V-LINK setting will be on.

In this state, you can operate the keyboard to manipulate images in sync with the playback of the V-piano.

2. Press the [V-LINK] button again.

The [V-LINK] button will go out, and the V-LINK setting will be off.

V-LINK function chart

V-LINK function	Transmitted MIDI message	V-Piano operation	Remarks
Switch images	CC#0: 00H-7FH CC#32: 00H-7FH	Play black keys	When V-LINK Mode is BANK/PC. Number depends on Lowest No.
	Program Change: 0-127	Play white keys	
	Note: A0-C8	Play keys	When V-LINK Mode is NOTE. Number depends on Lowest No.

V-LINK Settings



Parameter	Description	Value	Default Value
V-LINK Switch	Turns the V-LINK functionality on/off. This parameter is linked with the [V-LINK] button.	OFF, ON	OFF
V-LINK Mode	Selects the type of MIDI messages that will be transmitted. You can choose between transmitting bank select and program change messages (BANK/PC) or note messages (NOTE).	BANK/PC, NOTE	BANK/PC
V-LINK Tx Channel	Specifies the MIDI channel on which MIDI messages will be transmitted.	1-16	10
Key Range	Selects the range of keys that will be used as V-LINK controllers. You can also specify this range from the keyboard by pressing the bottom key, then the top key, and then [ENTER] button.	A0-C8	A0-G#1
Lowest No.	Specifies the number that will be transmitted when you press the lowest key of the Key Range.	1-128 (When V-LINK Mode is BANK/PC), 0-127 (When V-LINK Mode is NOTE)	1 (When V-LINK Mode is BANK/PC), 0 (When V-LINK Mode is NOTE)
Local Switch	Specifies whether the V-Piano will (ON) or will not (OFF) produce sound when you play a key in the specified Key Range.	OFF, ON	OFF

Restoring the factory settings (9. Initialize)



Deleting the user tones (Delete User Tone)

Here's how to delete a specific user tone.

1. In the Initialize screen, turn the [VALUE] dial to select "Delete User Tone," and then press the [ENTER] button or the [F1 (ENTER)] button.



2. Turn the [VALUE] dial to select the user tone that you want to delete.



3. To delete the selected user tone, press the [F4 (EXECUTE)] button.
4. A confirmation message will appear. To delete the user tone, press the [F4 (OK)] button.

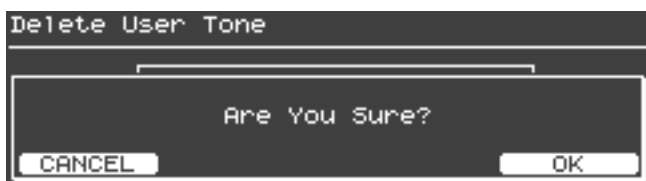

If you decide to cancel without deleting, press the [F1 (CANCEL)] button.

NOTE

The screen will indicate "Executing... Don't Power OFF" while the user tone is being deleted. Never turn off the power during this time.

5. When deletion is completed, press the [EXIT] button to return to the previous screen.

Factory reset (Factory Reset All)

This will erase the user tones and user setups stored in the V-Piano, resetting the V-Piano's settings to the factory-set state.

NOTE

When you execute "Factory Reset All," all user setups and user tones will be lost. If you want to keep the contents of memory, save your data to USB memory (sold separately) as a setup file (p. 87).

NOTE

All operations are disabled while the Factory Reset is being executed. Moreover, no sound be heard even if you play the keyboard.

NOTE

If the V-Piano is connected via USB to your computer, disconnect the USB cable before you execute this operation.

MEMO

Factory Reset does not return the internal memory (the area in which song data and setup files are stored) to the factory-set state. If you want to return the V-Piano's internal memory to the factory-set state, you must execute the Format operation on the internal memory (p. 95).

1. In the Initialize screen, turn the [VALUE] dial to select "Factory Reset All," and then press the [ENTER] button or the [F1 (ENTER)] button.

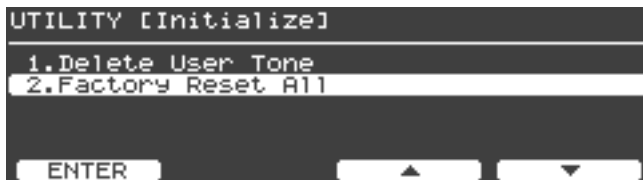

2. A confirmation message will appear.

The screen will indicate "Erases entire memory content and restores factory presets."

To execute the factory reset, press the [F4 (EXECUTE)] button.



To cancel without executing the factory reset, press the [EXIT] button.

3. A confirmation message will appear will appear.

To execute the factory reset, press the [F4 (OK)] button.

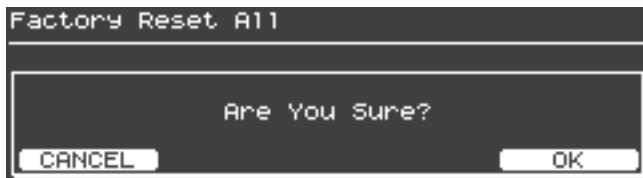

If you decide to cancel without executing, press the [F1 (CANCEL)] button or the [EXIT] button.

4. The message "Executing... Don't Power OFF" is shown while the factory reset is being executed. Never turn off the power during this time.
5. When the factory reset is finished, the screen will indicate "Power off, then on." Turn the V-Piano's power off, and then on again.

Playing or recording a song (10. Song)



When you select "10. Song," the Song screen will appear.

For details on operations in the Song screen, refer to "Playing songs and recording your performances" (p. 64).

Saving a setup (11. Setup Write)



Here's how a setup you've created can be saved as a user setup.

For details, refer to "Saving your settings (Setups)" (p. 59).

Troubleshooting

If the V-Piano does not function in the way you expect, first check the following points. If this does not resolve the problem, consult your dealer or a nearby Roland Service Station.

NOTE

If certain messages appear in the display during operation, please refer to "Error Messages" (p. 104).

Problem	Check/Solution	Page
Power not coming on	Is the V-Piano's power cord properly plugged into a power source as well as connected to the V-Piano?	p. 17
Buttons don't work	Could panel lock be active? <ul style="list-style-type: none"> Disengage the panel lock. 	p. 42
No sound	Is the power for connected amps and speakers turned on?	p. 22
	Is the volume turned all the way down?	p. 22
	Are all connections properly made? <ul style="list-style-type: none"> When using the V-Piano as a stand-alone instrument, be sure to connect with audio cables or use headphones. 	p. 18
	Are sounds audible with headphones connected? <ul style="list-style-type: none"> If sounds are audible through headphones, it may indicate that there is a short in an audio cable or some sort of amp or mixer problem. Check the cables and equipment once again. 	p. 18
	Is the Local Switch set to OFF? <ul style="list-style-type: none"> Set the Local Switch to ON. 	p. 81
	Could the volume have been lowered by pedal operations or by MIDI messages (volume messages and expression messages) received from an external MIDI device or from song data? <ul style="list-style-type: none"> Raise the Master Volume. Try switching Tones. 	p. 80 p. 34
No sound from the connected MIDI device	Does the V-Piano's MIDI transmit channel match the MIDI receive channel of the connected MIDI device? <ul style="list-style-type: none"> Set the MIDI transmit channel. 	p. 86
	Is V-LINK switched on? <ul style="list-style-type: none"> Set the Local ON/OFF to ON. Sounds are played with keyboard even when V-LINK is switched on. 	p. 96
Tones are altered	Did you call up a Setup? <ul style="list-style-type: none"> When a Setup is called up, the current Tone and other settings are disabled, and the selected Setup goes into effect. Resave required settings to a Setup. 	–
	If you're using a monaural connection, the tonal character may change depending on the Tone or the register. <ul style="list-style-type: none"> In order to enjoy the V-Piano's sound to its fullest potential, we recommend a stereo connection. If you're using a monaural connection, set Line Out Mode to MONO. 	p. 81
Sound is distorted	Some equalizer settings may cause the sound to distort. Try adjusting the equalizer's Input Gain.	p. 37
Pitch is odd	Depending on the Tone selected, pitches played in certain registers will be changed and played at other pitches.	–
	Have settings for Stretch Tune been made?	p. 54
	Has the V-Piano gone out of tune? Check the following settings. <ul style="list-style-type: none"> Master Tune settings Temperament settings 	p. 80
	Have you set Transpose?	p. 41
Song data not played back correctly	Are you playing back GS Format song data? <ul style="list-style-type: none"> Once the V-Piano receives a GS Reset message, it then is enabled for GS Format. This permits playback of music files bearing the GS logo (GS music files). However, data created exclusively for the Sound Canvas Series may not play back properly on the V-Piano. 	–
	Is the audio data playable? <ul style="list-style-type: none"> Make sure that the audio data can be played by the V-Piano. 	p. 75
Nothing appears in the screen	Since the V-Piano uses a liquid crystal screen, it may happen that no text or graphics appear in the screen if the temperature is below zero degrees Celsius (32 degrees Fahrenheit).	p. 23
Vertical lines appear in the screen/Color is "washed out" at the edges of the screen	These occur due to the nature of a liquid crystal display, and do not indicate a malfunction. They can be minimized by adjusting the contrast of the screen.	p. 23
Pedal does not work, or is "stuck"/ Pedal does not operate correctly	Is the pedal connected correctly? <ul style="list-style-type: none"> Plug the cord firmly into the pedal connector. 	p. 18
	Are you using a pedal made by another manufacturer? <ul style="list-style-type: none"> Use the pedal included with the V-Piano or an optional pedal. 	p. 107
Can't read or write USB memory successfully	Are you using (optional) Roland USB memory? <ul style="list-style-type: none"> Reliable performance cannot be guaranteed if you use non-Roland USB memory products. 	–
	If you are unable to read or write USB memory successfully, change the USB Memory Mode setting.	p. 80

Problem	Check/Solution	Page
Reverberation remains even if you turn off the ambience effect	Since the V-Piano simulates the sympathetic resonance of the strings, you may hear what sounds like reverberation even when Ambience is turned off.	–
The sound of the higher notes suddenly changes from a certain key	The tonal character will change at boundaries where there is a change in the number of strings per key or between wound and unwound strings.	–
High-pitched ringing is heard	Piano sounds that have a brilliant and crisp character contain substantial high-frequency components that may sound as though a metallic ringing has been added. This is because the character of an actual piano is being faithfully reproduced, and is not a malfunction. This ringing is more obtrusive if the ambience effect is applied heavily, so you may be able to minimize it by decreasing the ambience.	p. 39
Low notes sound wrong, or are buzzy	With certain tones, the sounds may seem to be distorted. Turn down the volume. Alternatively, lower the master gain setting.	p. 23
Can't rewind or fastforward	You can not rewind or fast-forward while music files are being read in. Wait until processing finishes.	–
	If you attempt to play back performance data that contains more data than the entire capacity of the V-Piano's memory, you may find that operations other than playback (such as rewind or fast forward) become unavailable.	–
Songs in USB memory are not played immediately	SMF music files comes in two types; formats 0 and 1. In the case of format 1 data, it may take a certain amount of time for playback to begin. The format type is indicated on the booklet for the music files you're using.	–

Error Messages

Indication:	Situation:	Action:
01 You can only read the music file.	You can only read the music file. It can not be saved.	–
02 An error occurred during writing.	An error occurred during writing.	The external media may not yet be initialized (p. 95).
10 No storage media is inserted.	No external media is inserted.	Insert the external media and try again.
11 Insufficient free memory at the save destination.	There is not enough free memory in the save destination.	Either use different external media, or delete unneeded files before you try the operation again.
14 An error occurred during reading.	An error occurred during reading. The external media may be corrupted.	–
15 The data format is not compatible with this instrument.	The file is unreadable. The data format is not compatible with the V-Piano.	Only files in the following formats can be used. <ul style="list-style-type: none"> • Setup files with an extension of "vsu" • SMF music files with an extension of "mid" • Audio files with an extension of "wav" or "mp3" For details on audio file formats, refer to "Types of audio data that the V-Piano can play" (p. 75).
16 Data could not be read fast enough for playback of the song.	Data was not called up in time for playback of the song.	You may be able to play the song after waiting a few seconds.
18 The audio data format is not compatible with this instrument.	The audio data format is not compatible with this instrument.	Use audio files of a format that meets the requirements given in "Types of audio data that the V-Piano can play" (p. 75).
30 The internal memory capacity of the V-Piano is full.	The internal memory capacity of the V-Piano is full.	–
40 The instrument can't deal with the excessive MIDI data.	The V-Piano cannot deal with the excessive MIDI data sent from the external MIDI device.	Reduce the amount of MIDI data sent to the V-Piano.
41 A MIDI cable has been disconnected.	A MIDI cable has been disconnected.	Connect it properly and securely.
43 A MIDI transmission error has occurred.	A MIDI transmission error has occurred.	Check the MIDI cable and connected MIDI device.
51 System error. Repeat procedure, or power off, then on.	There may be a problem with the system.	Repeat the procedure from the beginning. If it is not solved after you have tried several times, contact a Roland service center.
65 The USB Memory port was subjected to excessive current.	The USB memory connector was subjected to excessive current.	Make sure that there is no problem with the USB memory, then turn the power off, then on again.

List of shortcuts

By operating two or more buttons, knobs, or pedals simultaneously, you can directly and efficiently access a related function.

Function	Operation	Page
Change whether the tone buttons ([TONE 1] button – [TONE 4] button) will select tones or setups (i.e., change the Tone Button Mode)	Hold down the [FUNCTION] button and press the [F1] button	p. 59
Panel Lock on/off	Hold down the [FUNCTION] button and press a [TONE 1]–[TONE 4] button	p. 42
Assign a function to a pedal (access the Pedal Assign screen)	Hold down the [FUNCTION] button and press a pedal	p. 45
Access the V-LINK setting screen	Hold down the [FUNCTION] button and press the [V-LINK] button	p. 96
Select the Ambience type (access the Ambience setting screen)	Hold down the [Function] button and turn the [AMBIENCE] Knob	p. 39
Access the Utility screen	Hold down the [WRITE] button and press the [EXIT] button	p. 76
Access the V-PIANO DEMO screen	Hold down the [V-LINK] button and press the [TRANSPOSE] button	p. 32

Specifications

V-Piano: Digital Piano

Keyboard Section	
Keyboard	88 keys PHA III (Progressive Hammer Action III, Ivory feel Keyboard with Escapement)
Sound Generator Section (V-Piano)	
Part	1 Part
Maximum number of tone-producing virtual strings	264-string (varies according to the sound generator load)
Tones	Preset: 24 Tones User: 100 Tones
Setups	100
V-Piano editing parameters	Unison Tune Hammer Hardness Cross Resonance String Resonance Damper Resonance Soundboard Resonance Key Off Resonance Damping Noise Level and more
Effects	Ambience: 12 types 4-band Digital Equalizer
Sound Generator Section (GM2: playabel via SMF and MIDI)	
Parts	16 Parts
Maximum Polyphony	128 voices
Tones	256 Tones
Sequencer Section	
Playable File Format	Standard MIDI File: format-0/1 Audio File: WAV (44.1 kHz, 16-bit linear), MP3
Recording Format	Standard MIDI File: format-0
Number of Recording Tracks	1 track (realtime recording)
Note Capacity	approx. 30,000 notes
Control	Play/Stop Backward Forward Tempo Change Transpose Center Cancel (only for audio playback)
Tempo	Quarter note = 10 to 500 Audio Playback Speed: 75-125%
Resolution	120 ticks per quarter note
Song Length	Max 998 measures
Others	
Display	240 x 64 dot graphic LCD (with backlit)
Controllers	Volume knob Ambience knob
Pedal	Damper (half-pedal recognition) Soft (half-pedal recognition, function assignable) Sostenuto (function assignable)
Internal Memory	4M bytes
Other Functions	Panel Lock V-Link

Specifications

Connectors	<p>Output A (L/MONO, R): 1/4 inch phone type Output A (L, R): XLR type Output B (L/MONO, R): 1/4 inch phone type Output B (L, R): XLR type Input (L/MONO, R): 1/4 inch phone type Piano Pedal Damper Pedal Control Pedal (FC1, FC2) MIDI (IN, OUT, THRU) USB (MIDI, Memory, For Update) DIGITAL AUDIO OUT (COAXIAL) Headphones Jack: Stereo 1/4 inch phone type AC Inlet</p>
Power Supply	AC100V, AC117V, AC230V or AC240V(50/60Hz), AC220V (60Hz)
Power Consumption	27W
Dimensions	1,411 (W) x 530 (D) x 166 (H) mm / 55-9/16 (W) x 20-7/8 (D) x 6-9/16 (H) inches
Weight	38.2 kg / 84 lbs 4 oz
Accessories	<p>Owner's manual CD-ROM (Editor) Piano Pedal (Three Pedals, half-pedal recognition) USB Cable Power Cord</p>
Options	<p>Keyboard Stand: KS-V8, KS-G8 Damper Pedal: DP series Expression Pedal: EV-5, EV-7 Pedal Switch: BOSS FS-5U, FS-6 USB Memory CD Drive Audio Cable MIDI Cable</p>

* In the interest of product improvement, the specifications and/or appearance of this unit are subject to change without prior notice.

Index

A	
AC Inlet	14
Adjusting	
Display Contrast	23
Volume	23
Ambience	39
AMBIENCE Knob	12
Ambience settings	
Save	40
Show	30
Ambience type	39
AmbLvl	45
B	
Backing up	28
Basic information	29
C	
C.Reso	45
CD drive	25
CD-01A	25
Center Cancel	74
Connecting	
CD Drive	25
External Equipment	18
Headphone	21
Multi-channel speakers	21
Piano Pedal	20
USB Memory	24
Copy	
Setup File	91
Song File	94
Cross Resonance	49
D	
D.Nois	45
D.Reso	45
D.Time	45
DAMPER Connector	14
Damper Noise Level	50
Damper Pedal	20
Damper Resonance	48
Damping Time	50
Decay	45
Decay Time	49
Deep	54
Delete	
Setup File	90
Song File	93
Tone	98
DEMO screen	32
Demo song	32
DIGITAL OUT Connector	14
Display	12
Display Contrast	23
DISPLAY CONTRAST Knob	14
E	
Editor software	58
ENTER Button	12
Equalizer	37
EQUALIZER Button	12
Equalizer Settings	38
EXIT Button	13
Expres	45
F	
Factory Reset	99
FC1 Connector	14
FC2 Connector	14
Format	95
Function	
Assign to buttons	43
Assign to pedals	45
FUNCTION Button	12
G	
Gentle	54
H	
Hammer	45
Hammer Hardness	49
Headphone Jack	13
I	
Initializing	28
INPUT Jack	14
K	
K.Reso	45
Key Off Resonance	48
Keyboard touch	83
KS-G8	17
KS-V8	15
L	
Load	
Setup File	89
Local Switch	81
M	
M.Out	45
Master Tune	80
metronome	70
MIDI channel	86
MIDI Connectors	14
MP3 format	64, 75
O	
Original tone	58
OUTPUT Connector	14
P	
Panel Lock	42
PDL	30
Pedal Assignment	30
Phone (1/4") OUTPUT connector	19
PIANO PEDAL Connector	14
Play	66
PlayST	45
Power Cord	17
Power On	22
POWER Switch	14, 22
Preset tone	36
R	
RangeSet	55
Record	70
Reference pitch	80
Reset	45

S	
S.Lift	45
S.Reso	45
S/PDIF	14
Save	
Ambience settings	40
Equalizer settings	38
Setup	60
Setup file	87
Song	73
Song File	92
Tone	51
Security Slot	13
Select	
Setup	59
Tone	34
Setup	27
Assign to buttons	62
Save	60
Select	59
Setup File	
Copy	91
Delete	90
Load	89
Setup file	
Save	87
Show	
Ambience Setting	30
Original tone	58
Pedal Assignment	30
Sndbd	45
Soft	45
Soft Pedal	20
Soft Pedal Sense	48
Song	
Save	73
Song File	
Copy	94
Delete	93
Save	92
Song screen	64
Option	74
Sosten	45
Sostenuto Pedal	20
Sound Lift	48
Soundboard Resonance	48
Standard	54
Stop	69
Stretch Tune	49
String Resonance	48
SUP	30
SUP.Dn	45
SUP.Up	45
SYS	30
System parameter	27
T	
TColor	45
Temperament	80
Tempo	70
Tone	27
Assign to button	35
Delete	98
Edit	50
Save	51
Selecting	34
TONE Button	12
Tone Color	50
Tone EQ	82
Tone number	29
Tone screen	29
Trans	45
Transpose	41
TRANSDIAPHRAGM Button	12
Tuning	45
Tuning method	80
U	
Unison Tune	49, 57
USB memory	
Connecting	24
Format	95
Setup File	89
USB Memory Connector	13
USB MIDI Connector	14
Utility screen	76
V	
VALUE Dial	12
Velocity Follow	57
V-LINK	96
V-LINK Button	12
Volume	45
Adjusting	23
VOLUME Knob	12
V-PIANO DEMO screen	32
V-Piano Editor	58
W	
WAV format	64, 75
WRITE Button	13
X	
XLR connector	19
Z	
ZONE	82



For EU Countries

This product complies with the requirements of EMCD 2004/108/EC and LVD 2006/95/EC.

For the USA

FEDERAL COMMUNICATIONS COMMISSION RADIO FREQUENCY INTERFERENCE STATEMENT

This equipment has been tested and found to comply with the limits for a Class B digital device, pursuant to Part 15 of the FCC Rules. These limits are designed to provide reasonable protection against harmful interference in a residential installation. This equipment generates, uses, and can radiate radio frequency energy and, if not installed and used in accordance with the instructions, may cause harmful interference to radio communications. However, there is no guarantee that interference will not occur in a particular installation. If this equipment does cause harmful interference to radio or television reception, which can be determined by turning the equipment off and on, the user is encouraged to try to correct the interference by one or more of the following measures:

- Reorient or relocate the receiving antenna.
- Increase the separation between the equipment and receiver.
- Connect the equipment into an outlet on a circuit different from that to which the receiver is connected.
- Consult the dealer or an experienced radio/TV technician for help.

This device complies with Part 15 of the FCC Rules. Operation is subject to the following two conditions:

- (1) this device may not cause harmful interference, and
- (2) this device must accept any interference received, including interference that may cause undesired operation.

Unauthorized changes or modification to this system can void the users authority to operate this equipment.
This equipment requires shielded interface cables in order to meet FCC class B Limit.

For Canada

NOTICE

This Class B digital apparatus meets all requirements of the Canadian Interference-Causing Equipment Regulations.

AVIS

Cet appareil numérique de la classe B respecte toutes les exigences du Règlement sur le matériel brouilleur du Canada.

For C.A. US (Proposition 65)

WARNING

This product contains chemicals known to cause cancer, birth defects and other reproductive harm, including lead.

For the USA

DECLARATION OF CONFORMITY Compliance Information Statement

Model Name : V-PIANO
Type of Equipment : Digital Piano
Responsible Party : Roland Corporation U.S.
Address : 5100 S. Eastern Avenue, Los Angeles, CA 90040-2938
Telephone : (323) 890 3700

For EU Countries



- UK** This symbol indicates that in EU countries, this product must be collected separately from household waste, as defined in each region. Products bearing this symbol must not be discarded together with household waste.
- DE** Dieses Symbol bedeutet, dass dieses Produkt in EU-Ländern getrennt vom Hausmüll gesammelt werden muss gemäß den regionalen Bestimmungen. Mit diesem Symbol gekennzeichnete Produkte dürfen nicht zusammen mit dem Hausmüll entsorgt werden.
- FR** Ce symbole indique que dans les pays de l'Union européenne, ce produit doit être collecté séparément des ordures ménagères selon les directives en vigueur dans chacun de ces pays. Les produits portant ce symbole ne doivent pas être mis au rebut avec les ordures ménagères.
- IT** Questo simbolo indica che nei paesi della Comunità europea questo prodotto deve essere smaltito separatamente dai normali rifiuti domestici, secondo la legislazione in vigore in ciascun paese. I prodotti che riportano questo simbolo non devono essere smaltiti insieme ai rifiuti domestici. Ai sensi dell'art. 13 del D.Lgs. 25 luglio 2005 n. 151.
- ES** Este símbolo indica que en los países de la Unión Europea este producto debe recogerse aparte de los residuos domésticos, tal como está regulado en cada zona. Los productos con este símbolo no se deben depositar con los residuos domésticos.
- PT** Este símbolo indica que nos países da UE, a recolha deste produto deverá ser feita separadamente do lixo doméstico, de acordo com os regulamentos de cada região. Os produtos que apresentem este símbolo não deverão ser eliminados juntamente com o lixo doméstico.
- NL** Dit symbool geeft aan dat in landen van de EU dit product gescheiden van huishoudelijk afval moet worden aangeboden, zoals bepaald per gemeente of regio. Producten die van dit symbool zijn voorzien, mogen niet samen met huishoudelijk afval worden verwijderd.
- DK** Dette symbol angiver, at i EU-lande skal dette produkt opsamles adskilt fra husholdningsaffald, som defineret i hver enkelt region. Produkter med dette symbol må ikke smides ud sammen med husholdningsaffald.
- NO** Dette symbolet indikerer at produktet må behandles som spesialavfall i EU-land, iht. til retningslinjer for den enkelte regionen, og ikke kastes sammen med vanlig husholdningsavfall. Produkter som er merket med dette symbolet, må ikke kastes sammen med vanlig husholdningsavfall.
- SE** Symbolen anger att i EU-länder måste den här produkten kasseras separat från hushållsavfall, i enlighet med varje regions bestämmelser. Produkter med den här symbolen får inte kasseras tillsammans med hushållsavfall.
- FI** Tämä merkintä ilmaisee, että tuote on EU-maissa kerättävä erillään kotitalousjätteistä kunkin alueen voimassa olevien määräysten mukaisesti. Tällä merkinnällä varustettuja tuotteita ei saa hävittää kotitalousjätteiden mukana.
- HU** Ez a szimbólum azt jelenti, hogy az Európai Unióban ezt a terméket a háztartási hulladéktól elkülönítve, az adott régióban érvényes szabályozás szerint kell gyűjteni. Az ezzel a szimbóllummal ellátott termékeket nem szabad a háztartási hulladék közé dobni.
- PL** Symbol oznacza, że zgodnie z regulacjami w odpowiednim regionie, w krajach UE produktu nie należy wyrzucać z odpadami domowymi. Produktów opatrzonych tym symbolem nie można utylizować razem z odpadami domowymi.
- CZ** Tento symbol udává, že v zemích EU musí být tento výrobek sbírán odděleně od domácího odpadu, jak je určeno pro každý region. Výrobky nesoucí tento symbol se nesmí vyhazovat spolu s domácím odpadem.
- SK** Tento symbol vyjadruje, že v krajinách EÚ sa musí zber tohto produktu vykonávať oddelene od domového odpadu, podľa nariadení platných v konkrétnej krajine. Produkty s týmto symbolom sa nesmú vyhazovať spolu s domovým odpadom.
- EE** See sümbol näitab, et EL-i maades tuleb see toode olemprügist eraldi koguda, nii nagu on igas piirkonnas määratletud. Selle sümboliga märgitud tooteid ei tohi ära visata koos olmeprügiga.
- LT** Šis simbolis rodo, kad ES šalyse šis produktas turi būti surenkamas atskirai nuo buitinių atliekų, kaip nustatyta kiekviename regione. Šiuo simboliu paženklinėti produktai neturi būti išmetami kartu su buitiniemis atliekomis.
- LV** Šis simbols norāda, ka ES valstīs šo produktu jāievāc atsevišķi no mājsaimniecības atkritumiem, kā noteikts katrā reģionā. Produktus ar šo simbolu nedrīkst izmest kopā ar mājsaimniecības atkritumiem.
- SI** Ta simbol označuje, da je treba proizvod v državah EU zbirati ločeno od gospodinjiskih odpadkov, tako kot je določeno v vsaki regiji. Proizvoda s tem znakom ni dovoljeno odlagati skupaj z gospodinjiskimi odpadki.
- GR** Το σύμβολο αυτό υποδηλώνει ότι στις χώρες της Ε.Ε. το συγκεκριμένο προϊόν πρέπει να συλλέγεται χωριστά από τα υπόλοιπα οικιακά απορρίμματα, σύμφωνα με όσα προβλέπονται σε κάθε περιοχή. Τα προϊόντα που φέρουν το συγκεκριμένο σύμβολο δεν πρέπει να απορρίπτονται μαζί με τα οικιακά απορρίμματα.

有关产品中所含有害物质的说明

本资料就本公司产品中所含的特定有害物质及其安全性予以说明。

本资料适用于 2007 年 3 月 1 日以后本公司所制造的产品。

环保使用期限



此标志适用于在中国国内销售的电子信息产品，表示环保使用期限的年数。所谓环保使用期限是指在自制造日起的规定期限内，产品中所含的有害物质不致引起环境污染，不会对人身、财产造成严重的不良影响。

环保使用期限仅在遵照产品使用说明书，正确使用产品的条件下才有效。

不当的使用，将会导致有害物质泄漏的危险。

产品中有毒有害物质或元素的名称及含量

部件名称	有毒有害物质或元素					
	铅(Pb)	汞(Hg)	镉(Cd)	六价铬(Cr(VI))	多溴联苯(PBB)	多溴二苯醚(PBDE)
外壳(壳体)	×	○	○	○	○	○
电子部件(印刷电路板等)	×	○	×	○	○	○
附件(电源线、交流适配器等)	×	○	○	○	○	○

○：表示该有毒有害物质在该部件所有均质材料中的含量均在 SJ/T11363-2006 标准规定的限量要求以下。
 ×：表示该有毒有害物质至少在该部件的某一均质材料中的含量超出 SJ/T11363-2006 标准规定的限量要求。
 因根据现有的技术水平，还没有什么物质能够代替它。

Information

When you need repair service, call your nearest Roland Service Center or authorized Roland distributor in your country as shown below.

AFRICA

REUNION

MARCEL FO-YAM Sarl
25 Rue Jules Hermann,
Chaudron - BP79 97 491
Ste Clotilde Cedex,
REUNION ISLAND
TEL: (0262) 218-429

SOUTH AFRICA

Paul Bothner(PTY)Ltd.
Royal Cape Park, Unit 24
Londonderry Road, Ottery 7800
Cape Town, SOUTH AFRICA
TEL: (021) 799 4900

ASIA

CHINA

Roland Shanghai Electronics Co.,Ltd.
5F, No.1500 Pingliang Road,
Yangpu Shanghai 200090, CHINA
TEL: (021) 5580-0800
Toll Free: 4007-888-010

Roland Shanghai Electronics Co.,Ltd. (BEIJING OFFICE)

3F, Soluxe Fortune Building
63 West Dawang Road,
Chaoyang Beijing, CHINA
TEL: (010) 5960-2565/0777
Toll Free: 4007-888-010

HONG KONG

Tom Lee Music
11/F Silvercord Tower 1
30 Canton Rd
Tsimshatsui, Kowloon,
HONG KONG
TEL: 852-2737-7688

Parsons Music Ltd.

8th Floor, Railway Plaza, 39
Chatham Road South, T.S.T,
Kowloon, HONG KONG
TEL: 852-2333-1863

INDIA

Rivera Digitech (India) Pvt. Ltd.
411, Nirman Kendra Mahalaxmi
Flats Compound Off. Dr. Edwin
Moses Road, Mumbai-400011,
INDIA
TEL: (022) 2493 9051

INDONESIA

PT. Citra Intirama
Ruko Garden Shopping Arcade
Unit 8 CR, Podomoro City
Jl.Letjend. S.Perman Kav.28
Jakarta Barat 11470, INDONESIA
TEL: (021) 5698-5519/5520

KAZAKHSTAN

Alatau Dybystary
141 Abylai-Khan ave, 1st floor,
050000 Almaty, KAZAKHSTAN
TEL: (727) 2725477
FAX: (727) 2720730

KOREA

Cosmos Corporation
27, Banpo-daero, Seocho-gu,
Seoul, KOREA
TEL: (02) 3486-8855

MALAYSIA/SINGAPORE

Roland Asia Pacific Sdn. Bhd.
45-1, Block C2, Jalan PJU 1/39,
Dataran Prima, 47301 Petaling
Jaya, Selangor, MALAYSIA
TEL: (03) 7805-3263

PHILIPPINES

G.A. Yupangco & Co. Inc.
339 Gil J. Puyat Avenue
Makati, Metro Manila 1200,
PHILIPPINES
TEL: (02) 899 9801

TAIWAN

ROLAND TAIWAN ENTERPRISE CO., LTD.
9F-5, No. 112 Chung Shan
North Road Sec. 2 Taipei 104,
TAIWAN R.O.C.
TEL: (02) 2561 3339

THAILAND

Theera Music Co., Ltd.
100-108 Soi Verg
Nakornkasem, New Road,
Sumpantawong, Bangkok
10100, THAILAND
TEL: (02) 224-8821

VIET NAM

VIET THUONG CORPORATION
386 CACH MANG THANG TAM ST.
DIST.3, HO CHI MINH CITY,
VIET NAM
TEL: (08) 9316540

OCEANIA

AUSTRALIA/ NEW ZEALAND

**Roland Corporation
Australia Pty.,Ltd.**
38 Campbell Avenue, Dee Why
West. NSW 2099, AUSTRALIA

For Australia
TEL: (02) 9982 8266

For New Zealand
TEL: (09) 3098 715

CENTRAL/LATIN AMERICA

ARGENTINA

Instrumentos Musicales S.A.
Av.Santa Fe 2055
(1123) Buenos Aires, ARGENTINA
TEL: (011) 4508-2700

BARBADOS

A&B Music Supplies LTD
12 Webster Industrial Park
Wildy, St.Michael, BARBADOS
TEL: (246) 430-1100

BRAZIL

Roland Brasil Ltda.
Rua San Jose, 211
Parque Industrial San Jose
Cotia - Sao Paulo - SP, BRAZIL
TEL: (011) 4615 5666

CHILE

Comercial Fancy II S.A.
Rut.: 96.919.420-1
Nataliel Cox #739, 4th Floor
Santiago - Centro, CHILE
TEL: (02) 384-2180

COLOMBIA

CENTRO MUSICAL S.A.S.
Parque Industrial del Norte
Bodega 130
GIRARDOTA - ANTIOQUIA,
COLOMBIA
TEL: (454) 57 77 EXT 115

COSTA RICA

**JUAN BANSBACH Instrumentos
Musicales**
Ave.1. Calle 11, Apartado 10237,
San Jose, COSTA RICA
TEL: 258-0211

CURACAO

Zeelandia Music Center Inc.
Orionweg 30
Curacao, Netherland Antilles
TEL: (305) 5926866

DOMINICAN REPUBLIC

Instrumentos Fernando Giraldez
Calle Roberto Pastoriza #325
Sanchez Naco Santo Domingo,
DOMINICAN REPUBLIC
TEL: (809) 683 0305

ECUADOR

Mas Musica
Rumichaca 822 y Zaruma
Guayaquil - ECUADOR
TEL: (593-4) 2302364

EL SALVADOR

OMNI MUSIC
75 Avenida Norte y Final Alameda
Juan Pablo II, Edificio No.4010
San Salvador, EL SALVADOR
TEL: 262-0788

GUATEMALA

Casa Instrumental
Calzada Roosevelt 34-01,zona
11 Ciudad de Guatemala,
GUATEMALA
TEL: (502) 599-2888

HONDURAS

Almacen Pajaro Azul S.A. de C.V.
BO.Paz Barahona
3 Ave.11 Calle S.O
San Pedro Sula, HONDURAS
TEL: (504) 553-2029

MARTINIQUE

Musique & Son
Z.I.Les Mangle
97232 Le Lamentin,
MARTINIQUE F.W.I.
TEL: 596 596 426860

MEXICO

Casa Veerkamp, s.a. de c.v.
Av. Toluca No. 323, Col. Olivar
de los Padres 01780 Mexico D.F.,
MEXICO
TEL: (55) 5668-6699

Faly Music

Sucursal Capu Blvd. Norte N.3213
Col. Nueva Aurora Cp.72070
Puebla, Puebla, MEXICO
TEL: 01 (222) 2315567 o 97
FAX: 01 (222) 2266241

Gama Music S.A. de C.V.

Madero Pte. 810 Colonia Centro
C.P. 64000 Monterrey, Nuevo
León, MEXICO
TEL: 01 (81) 8374-1640 o 8372-4097
www.gamamusic.com

Proscania

Morelos No. 2273
Col. Arcos Sur
C.P. 44120 Guadalupe, Jalisco,
MEXICO
TEL: 01(33) 3630-0015

NICARAGUA

**Bansbach Instrumentos
Musicales Nicaragua**
Altamira D'Este Calle Principal
de la Farmacia 5ta.Avenida
1 Cuadra al Lago.#503
Managua, NICARAGUA
TEL: (505) 277-2557

PANAMA

SUPRO MUNDIAL, S.A.
Boulevard Andrews, Albrook,
Panama City, REP. DE PANAMA
TEL: 315-0101

PARAGUAY

WORLD MUSIC
Jebai Center 2018, Centro
CIUDAD DE ESTE, PARAGUAY
TEL: (595) 615 059

PERU

**AUDIONET DISTRIBUCIONES
MUSICALES SAC**
Jr. Ramon Dagnino N°201- Jesús
María
DISTRITO DE JESUS MARIA
LIMA, PERU
TEL: 9 983 47 301 - 51 433 80 83
1771

TRINIDAD

AMR Ltd
Ground Floor
Maritime Plaza
Barataria TRINIDAD W.I.
TEL: (868) 638 6385

URUGUAY

Todo Musica S.A.
Francisco Acuna de Figueroa
1771
C.P.: 11.800
Montevideo, URUGUAY
TEL: (02) 924-2335

VENEZUELA

**Instrumentos Musicales
Allegro, C.A.**
Av.Ias Industrias edf.Guitar
import #7 zona Industrial de
Turumo Caracas, VENEZUELA
TEL: (212) 244-1122

EUROPE

BELGIUM/FRANCE/ HOLLAND/ LUXEMBOURG

Roland Central Europe N.V.
Houtstraat 3, B-2260, Oevel
(Westerlo) BELGIUM
TEL: (014) 575811

BOSNIA AND HERZEGOVINA

Mix-AP Music
78000 Banja Luka, Veselina
Maslese 3,
BOSNIA AND HERZEGOVINA
TEL: 65 403 168

CROATIA

ART-CENTAR
Degenova 3,
HR - 10000 Zagreb, CROATIA
TEL: (1) 466 8493

EUROMUSIC AGENCY

K. Racina 1/15
HR - 40000 CAKOVEC, CROATIA
Tel: 40-370-841

CZECH REPUBLIC

**CZECH REPUBLIC
DISTRIBUTOR s.r.o.**
Pod Báni 8
180 00 Praha 8, CZECH REP.
TEL: 266 312 557

DENMARK/ESTONIA/ LATVIA/LITHUANIA/

Roland Scandinavia A/S
Skagerrakvej 7, DK-2150
Nordhavn, DENMARK
TEL: 39166200

FINLAND

**Roland Scandinavia As, Filial
Finland**
Vanha Nurmijarventie 62
01670 Vantaa, FINLAND
TEL: (0) 9 68 24 020

GERMANY/AUSTRIA

ROLAND Germany GmbH.
Adam-Opel-Strasse 4, 64569
Nauheim, GERMANY
TEL: 6152 95546-00

GREECE/CYPRUS

STOLLAS S.A.

Music Sound Light
155, New National Road
Patras 26442, GREECE
TEL: 2610 435400

HUNGARY

Roland East Europe Ltd.
2045, Törökbalint, FSD Park 3. ép.,
HUNGARY
TEL: (23) 511 011

IRELAND

Roland Ireland
E2 Calmount Park, Calmount
Avenue, Dublin 12,
Republic of IRELAND
TEL: (01) 4294444

ITALY

Roland Italy S. p. a.
Viale delle Industrie 8,
20020 Arese, Milano, ITALY
TEL: (02) 937781

MACEDONIA

MK MJUZIK
Bratstvo Edinstvo 9
2208 Lozovo, MACEDONIA
TEL: 70 264 458

MONTENEGRO

MAX-AP
P. Fah 92
Przno, Kamenovo bb
86000 Budva, MONTENEGRO
TEL: 33 452-820

NORWAY

**Roland Scandinavia Avd.
Kontor Norge**
Lilleakerveien 2 Postboks 95
Lilleaker N-0216 Oslo,
NORWAY
TEL: 2273 0074

POLAND

ROLAND POLSKA SP. Z O.O.
ul. Katy Grodziskie 16B
03-289 Warszawa, POLAND
TEL: (022) 678 9512

PORTUGAL

Roland Iberia SL
Branch Office Porto
Edificio Tower Plaza
Rotunda Eng. Edgar Cardoso 23,
4-B
4400-676 Vila Nova de Gaia,
PORTUGAL
TEL: (+351) 22 608 00 60

ROMANIA

Pro Music Concept SRL
440221 Satu Mare
B-dul Independentei nr. 14/a.,
ROMANIA
TEL: (0361) 807-333

RUSSIA

Roland Music LLC
Dorozhnaya ul.3,korp.6
117 545 Moscow, RUSSIA
TEL: (495) 981-4967

SERBIA

Music AP
Sutjeska br. 5 XS - 24413 PALIC,
SERBIA
TEL: (0) 24 539 395

SLOVAKIA

DAN Distribution, s.r.o.
Povazská 18,
SK - 940 01 Nové Zámky,
SLOVAKIA
TEL: (035) 6424 330

SPAIN

Roland Systems Group EMEA, S.L.
Paseo García Faria, 33-35
08005 Barcelona, SPAIN
TEL: 93 493 91 00

SWEDEN

Roland Scandinavia A/S
SWEDISH SALES OFFICE
Märbackagatan 31, 4 tr.
SE-123 43 Farsta, SWEDEN
TEL: (0) 8 683 04 30

SWITZERLAND

Roland (Switzerland) AG
Landstrasse 5, Postfach,
CH-4452 Itingen, SWITZERLAND
TEL: (061) 975-9987

TURKEY

ZUHAL DIS TICARET A.S.
Galip Dede Cad. No.33
Beyoglu, Istanbul, TURKEY
TEL: (0212) 249 85 10

UKRAINE

EURHYTHMICS Ltd.
P.O.Box: 37-a,
Nedecey Str. 30
UA - 89600 Mukachevo,
UKRAINE
TEL: (03131) 314-40

UNITED KINGDOM

Roland (U.K.) Ltd.
Atlantic Close, SWANSEA SA7
9FJ, UNITED KINGDOM
TEL: (01792) 702701

MIDDLE EAST

BAHRAIN

Moon Stores
No.1231&1249 Rumaytha
Building Road 3931,
Manama 339, BAHRAIN
TEL: 17 813 942

EGYPT

Al Fanny Trading Office
9, EBN Hagar Al Askalany Street,
ARD E1 Golf, Heliopolis,
Cairo 11341, EGYPT
TEL: (022)-417-1828

IRAN

MOCO INC.
Jadeh Makhsoos Karaj (K-9),
Nakhe Zarin Ave.
Jafar Street, Reza Alley No.4
Tehran 1389716791, IRAN
TEL: (021)-44545370-5

ISRAEL

**Halilit P. Greenspoon &
Sons Ltd.**
8 Retzif Ha'alia Hashnia St.
Tel-Aviv-Yafo ISRAEL
TEL: (03) 6823666

JORDAN

MUSIC HOUSE CO. LTD.
FREDDY FOR MUSIC
P. O. Box 922846
Amman 11192, JORDAN
TEL: (06) 5692696

KUWAIT

**EASA HUSAIN AL-YOUSIFI &
SONS CO.**
Al-Yousifi Service Center
P.O.Box 126 (Safat) 13002,
KUWAIT
TEL: 00 965 802929

LEBANON

Chahine S.A.L.
George Zeidan St., Chahine Bldg.,
Achrafieh, P.O.Box: 16-5857
Beirut, LEBANON
TEL: (01) 20-1441

OMAN

TALENTZ CENTRE L.L.C.
Malatan House No.1
Al Noor Street, Ruwi
SULTANATE OF OMAN
TEL: 2478 3443

QATAR

**AL-EMADI TRADING &
CONTRACTING CO.**
P.O. Box 62, Doha, QATAR
TEL: 4423-554

SAUDI ARABIA

**Adawlah Universal
Electronics APL**
Behind Pizza Inn
Prince Turkey Street
Adawlah Building,
PO BOX 2154,
Al Khobar 31952,
SAUDI ARABIA
TEL: (03) 8643601

SYRIA

Technical Light & Sound Center
PO Box 13520 Bldg No.49
Khaled Abn Alwalid St.
Damascus, SYRIA
TEL: (011) 223-5384

U.A.E.

**Adawlah Universal
Electronics APL**
Omar bin alkhattab street, fish
round about, nayef area, deira,
Dubai, U.A.E.
TEL: (04) 2340442

NORTH AMERICA

CANADA

Roland Canada Ltd.
(Head Office)
5480 Parkwood Way Richmond
B. C., V6V 2M4, CANADA
TEL: (604) 270 6626

Roland Canada Ltd.

(Toronto Office)
170 Admiral Boulevard
Mississauga ON L5T 2N6,
CANADA
TEL: (905) 362 9707

U. S. A.

Roland Corporation U.S.
5100 S. Eastern Avenue
Los Angeles, CA 90040-2938,
U. S. A.
TEL: (323) 890 3700

Roland

