



# RD-800

Owner's Manual

Roland

## Owner's Manual (this document)

Read this first. It explains the basic things you need to know in order to use the RD-800.



## PDF Manual (download from the Web)

- **Effect Parameter Guide**  
This explains the effect parameters of the RD-800.
- **Sound List**  
This is a list of the sounds built into the RD-800.
- **MIDI Implementation**  
This is detailed information about MIDI messages.

## To obtain the PDF manual

1. Enter the following URL in your computer.  
<http://www.roland.com/manuals/>  
▼
2. Choose "RD-800" as the product name.

**WARNING:** To reduce the risk of fire or electric shock, do not expose this apparatus to rain or moisture.

	<b>CAUTION</b> RISK OF ELECTRIC SHOCK DO NOT OPEN	
<b>ATTENTION:</b> RISQUE DE CHOC ELECTRIQUE NE PAS OUVRIR		
<b>CAUTION:</b> TO REDUCE THE RISK OF ELECTRIC SHOCK, DO NOT REMOVE COVER (OR BACK). NO USER-SERVICEABLE PARTS INSIDE. REFER SERVICING TO QUALIFIED SERVICE PERSONNEL.		



The lightning flash with arrowhead symbol, within an equilateral triangle, is intended to alert the user to the presence of uninsulated "dangerous voltage" within the product's enclosure that may be of sufficient magnitude to constitute a risk of electric shock to persons.



The exclamation point within an equilateral triangle is intended to alert the user to the presence of important operating and maintenance (servicing) instructions in the literature accompanying the product.

INSTRUCTIONS PERTAINING TO A RISK OF FIRE, ELECTRIC SHOCK, OR INJURY TO PERSONS.

## IMPORTANT SAFETY INSTRUCTIONS SAVE THESE INSTRUCTIONS

**WARNING** - When using electric products, basic precautions should always be followed, including the following:

1. Read these instructions.
2. Keep these instructions.
3. Heed all warnings.
4. Follow all instructions.
5. Do not use this apparatus near water.
6. Clean only with a dry cloth.
7. Do not block any of the ventilation openings. Install in accordance with the manufacturers instructions.
8. Do not install near any heat sources such as radiators, heat registers, stoves, or other apparatus (including amplifiers) that produce heat.
9. Do not defeat the safety purpose of the polarized or grounding-type plug. A polarized plug has two blades with one wider than the other. A grounding type plug has two blades and a third grounding prong. The wide blade or the third prong are provided for your safety. If the provided plug does not fit into your outlet, consult an electrician for replacement of the obsolete outlet.
10. Protect the power cord from being walked on or pinched particularly at plugs, convenience receptacles, and the point where they exit from the apparatus.
11. Only use attachments/accessories specified by the manufacturer.
12. Use only with the cart, stand, tripod, bracket, or table specified by the manufacturer, or sold with the apparatus. When a cart is used, use caution when moving the cart/apparatus combination to avoid injury from tip-over.
13. Unplug this apparatus during lightning storms or when unused for long periods of time.
14. Refer all servicing to qualified service personnel. Servicing is required when the apparatus has been damaged in any way, such as power-supply cord or plug is damaged, liquid has been spilled or objects have fallen into the apparatus, the apparatus has been exposed to rain or moisture, does not operate normally, or has been dropped.



For the U.K.

**IMPORTANT:** THE WIRES IN THIS MAINS LEAD ARE COLOURED IN ACCORDANCE WITH THE FOLLOWING CODE.

BLUE: NEUTRAL  
BROWN: LIVE

As the colours of the wires in the mains lead of this apparatus may not correspond with the coloured markings identifying the terminals in your plug, proceed as follows:

The wire which is coloured BLUE must be connected to the terminal which is marked with the letter N or coloured BLACK.



The wire which is coloured BROWN must be connected to the terminal which is marked with the letter L or coloured RED.

Under no circumstances must either of the above wires be connected to the earth terminal of a three pin plug.



# USING THE UNIT SAFELY

## INSTRUCTIONS FOR THE PREVENTION OF FIRE, ELECTRIC SHOCK, OR INJURY TO PERSONS

### About ⚠ WARNING and ⚠ CAUTION Notices

 <b>WARNING</b>	Used for instructions intended to alert the user to the risk of death or severe injury should the unit be used improperly.
 <b>CAUTION</b>	Used for instructions intended to alert the user to the risk of injury or material damage should the unit be used improperly. * Material damage refers to damage or other adverse effects caused with respect to the home and all its furnishings, as well to domestic animals or pets.

### About the Symbols

	The ⚠ symbol alerts the user to important instructions or warnings. The specific meaning of the symbol is determined by the design contained within the triangle. In the case of the symbol at left, it is used for general cautions, warnings, or alerts to danger.
	The ⚡ symbol alerts the user to items that must never be carried out (are forbidden). The specific thing that must not be done is indicated by the design contained within the circle. In the case of the symbol at left, it means that the unit must never be disassembled.
	The ● symbol alerts the user to things that must be carried out. The specific thing that must be done is indicated by the design contained within the circle. In the case of the symbol at left, it means that the power-cord plug must be unplugged from the outlet.

## ALWAYS OBSERVE THE FOLLOWING

### WARNING

#### To completely turn off power to the unit, pull out the plug from the outlet

Even with the [⏻] switch turned off, this unit is not completely separated from its main source of power. When the power needs to be completely turned off, turn off the [⏻] switch on the unit, then pull out the plug from the outlet. For this reason, the outlet into which you choose to connect the power cord's plug should be one that is within easy reach and readily accessible.



#### Concerning the Auto Off function

The power to this unit will be turned off automatically after a predetermined amount of time has passed since it was last used for playing music, or its buttons or controls were operated (Auto Off function). If you do not want the power to be turned off automatically, disengage the Auto Off function (p. 27).



#### Do not disassemble or modify by yourself

Do not carry out anything unless you are instructed to do so in the owner's manual. Otherwise, you risk causing malfunction.



#### Do not repair or replace parts by yourself

Refer all servicing to your retailer, the nearest Roland Service Center, or an authorized Roland distributor, as listed on the "Information."



### WARNING

#### Do not use or store in the following types of locations

- Subject to temperature extremes (e.g., direct sunlight in an enclosed vehicle, near a heating duct, on top of heat-generating equipment); or are
- Damp (e.g., baths, washrooms, on wet floors); or are
- Exposed to steam or smoke; or are
- Subject to salt exposure; or are
- Exposed to rain; or are
- Dusty or sandy; or are
- Subject to high levels of vibration and shakiness.



#### Use only the stand that is recommended

This unit should be used only with a stand that is recommended by Roland.



#### Do not place in a location that is unstable

When using the unit with a stand recommended by Roland, the stand must be carefully placed so it is level and sure to remain stable. If not using a stand, you still need to make sure that any location you choose for placing the unit provides a level surface that will properly support the unit, and keep it from wobbling.



#### Precautions regarding placement of this unit on a stand

Be sure to follow the instructions in the Owner's Manual carefully when placing this unit on a stand (p. 8). If it is not set up properly, you risk creating an unstable situation which could lead to the unit falling or the stand toppling, and may result in injury.



### WARNING

#### Connect the power cord to an outlet of the correct voltage

The unit should be connected to a power supply only of the type described as marked on the rear side of unit.



#### Use only the supplied power cord

Use only the attached power cord. Also, the supplied power cord must not be used with any other device.



#### Do not bend the power cord or place heavy objects on it

Otherwise, fire or electric shock may result.



#### Avoid extended use at high volume

Use of the unit at high volume for extended periods of time may cause hearing loss. If you ever experience any hearing loss or ringing in the ears, you should immediately stop using the unit and consult a specialized physician.



#### Do not allow foreign objects or liquids to enter unit; never place containers with liquid on unit

Do not place containers containing liquid (e.g., flower vases) on this product. Never allow foreign objects (e.g., flammable objects, coins, wires) or liquids (e.g., water or juice) to enter this product. Doing so may cause short circuits, faulty operation, or other malfunctions.



## USING THE UNIT SAFELY

### WARNING

#### Turn off the unit if an abnormality or malfunction occurs

Immediately turn the unit off, remove the power cord from the outlet, and request servicing by your retailer, the nearest Roland Service Center, or an authorized Roland distributor, as listed on the "Information" when:

- The power cord has been damaged; or
- If smoke or unusual odor occurs; or
- Objects have fallen into, or liquid has been spilled onto the unit; or
- The unit has been exposed to rain (or otherwise has become wet); or
- The unit does not appear to operate normally or exhibits a marked change in performance.



#### Be cautious to protect children from injury

Always make sure that an adult is on hand to provide supervision and guidance when using the unit in places where children are present, or when a child will be using the unit.



#### Do not drop or subject to strong impact

Otherwise, you risk causing damage or malfunction.



#### Do not share an outlet with an unreasonable number of other devices

Otherwise, you risk overheating or fire.



#### Do not use overseas

Before using the unit in overseas, consult with your retailer, the nearest Roland Service Center, or an authorized Roland distributor, as listed on the "Information."



### CAUTION

#### Place in a well ventilated location

The unit should be located so that its location or position does not interfere with its proper ventilation.



#### Use only the specified stand(s)

This unit is designed to be used in combination with specific stands (KS-G8, KS-G8B) manufactured by Roland. If used in combination with other stands, you risk sustaining injuries as the result of this product dropping down or toppling over due to a lack of stability.



#### Evaluate safety issues before using stands

Even if you observe the cautions given in the owner's manual, certain types of handling may allow this product to fall from the stand, or cause the stand to overturn. Please be mindful of any safety issues before using this product.



#### When disconnecting the power cord, grasp it by the plug

To prevent conductor damage, always grasp the power cord by its plug when disconnecting it from this unit or from a power outlet.



#### Periodically clean the power plug

An accumulation of dust or foreign objects between the power plug and the power outlet can lead to fire or electric shock.



At regular intervals, be sure to pull out the power plug, and using a dry cloth, wipe away any dust or foreign objects that may have accumulated.

#### Disconnect the power plug whenever the unit will not be used for an extended period of time

Fire may result in the unlikely event that a breakdown occurs.



#### Route all power cords and cables in such a way as to prevent them from getting entangled

Injury could result if someone were to trip on a cable and cause the unit to fall or topple.



#### Avoid climbing on top of the unit, or placing heavy objects on it

Otherwise, you risk injury as the result of the unit toppling over or dropping down.



#### Never connect/disconnect a power plug if your hands are wet

Otherwise, you could receive an electric shock.



### CAUTION

#### Disconnect all cords/cables before moving the unit

Before moving the unit, disconnect the power plug from the outlet, and pull out all cords from external devices.



#### Before cleaning the unit, disconnect the power plug from the outlet

If the power plug is not removed from the outlet, you risk receiving an electric shock.



#### Whenever there is a threat of lightning, disconnect the power plug from the outlet

If the power plug is not removed from the outlet, you risk receiving an electric shock.



# IMPORTANT NOTES

## Power Supply

- Do not connect this unit to same electrical outlet that is being used by an electrical appliance that is controlled by an inverter or a motor (such as a refrigerator, washing machine, microwave oven, or air conditioner). Depending on the way in which the electrical appliance is used, power supply noise may cause this unit to malfunction or may produce audible noise. If it is not practical to use a separate electrical outlet, connect a power supply noise filter between this unit and the electrical outlet.

## Placement

- Using the unit near power amplifiers (or other equipment containing large power transformers) may induce hum. To alleviate the problem, change the orientation of this unit; or move it farther away from the source of interference.
- This unit may interfere with radio and television reception. Do not use this unit in the vicinity of such receivers.
- Noise may be produced if wireless communications devices, such as cell phones, are operated in the vicinity of this unit. Such noise could occur when receiving or initiating a call, or while conversing. Should you experience such problems, you should relocate such wireless devices so they are at a greater distance from this unit, or switch them off.
- Do not expose the unit to direct sunlight, place it near devices that radiate heat, leave it inside an enclosed vehicle, or otherwise subject it to temperature extremes. Excessive heat can deform or discolor the unit.
- When moved from one location to another where the temperature and/or humidity is very different, water droplets (condensation) may form inside the unit. Damage or malfunction may result if you attempt to use the unit in this condition. Therefore, before using the unit, you must allow it to stand for several hours, until the condensation has completely evaporated.
- Do not allow objects to remain on top of the keyboard. This can be the cause of malfunction, such as keys ceasing to produce sound.
- Depending on the material and temperature of the surface on which you place the unit, its rubber feet may discolor or mar the surface. You can place a piece of felt or cloth under the rubber feet to prevent this from happening. If you do so, please make sure that the unit will not slip or move accidentally.
- Do not place containers or anything else containing liquid on top of this unit. Also, whenever any liquid has been spilled on the surface of this unit, be sure to promptly wipe it away using a soft, dry cloth.

## Maintenance

- For everyday cleaning wipe the unit with a soft, dry cloth or one that has been slightly dampened with water. To remove stubborn dirt, use a cloth impregnated with a mild, non-abrasive detergent. Afterwards, be sure to wipe the unit thoroughly with a soft, dry cloth.
- Never use benzine, thinners, alcohol or solvents of any kind, to avoid the possibility of discoloration and/or deformation.

## Repairs and Data

- Before sending the unit away for repairs, be sure to make a backup of the data stored within it; or you may prefer to write down the needed information. Although we will do our utmost to preserve the data stored in your unit when we carry out repairs, in some cases, such as when the memory section is physically damaged, restoration of the stored content may be impossible. Roland assumes no liability concerning the restoration of any stored content that has been lost.

## Additional Precautions

- Any data stored within the unit can be lost as the result of equipment failure, incorrect operation, etc. To protect yourself against the irretrievable loss of data, try to make a habit of creating regular backups of the data you've stored in the unit.
- Roland assumes no liability concerning the restoration of any stored content that has been lost.
- Use a reasonable amount of care when using the unit's buttons, sliders, or other controls; and when using its jacks and connectors. Rough handling can lead to malfunctions.
- Never strike or apply strong pressure to the display.
- When disconnecting all cables, grasp the connector itself—never pull on the cable. This way you will avoid causing shorts, or damage to the cable's internal elements.
- A small amount of heat will radiate from the unit during normal operation.
- To avoid disturbing others nearby, try to keep the unit's volume at reasonable levels.
- The sound of keys being struck and vibrations produced by playing an instrument can be transmitted through a floor or wall to an unexpected extent. Please take care not to cause annoyance to others nearby.
- When you need to transport the unit, pack it in shock-absorbent material. Transporting the unit without doing so can cause it to become scratched or damaged, and could lead to malfunction.
- Use only the specified expression pedal (EV-5, EV-7; sold separately). By connecting any other expression pedals, you risk causing malfunction and/or damage to the unit.

## Using External Memories

- Please observe the following precautions when handling external memory devices. Also, make sure to carefully observe all the precautions that were supplied with the external memory device.
  - Do not remove the device while reading/writing is in progress.
  - To prevent damage from static electricity, discharge all static electricity from your person before handling the device.

## Care of the keyboard

- Do not write on the keyboard with any pen or other implement, and do not stamp or place any marking on the instrument. Ink will seep into the surface lines and become unremovable.
- Do not affix stickers on the keyboard. You may be unable to remove stickers that use strong adhesives, and the adhesive may cause discoloration.
- To remove stubborn dirt, use a commercially available keyboard cleaner that does not contain abrasives. Start by wiping lightly. If the dirt does not come off, wipe using gradually increasing amounts of pressure while taking care not to scratch the keys.

## Intellectual Property Right

- It is forbidden by law to make an audio recording, video recording, copy or revision of a third party's copyrighted work (musical work, video work, broadcast, live performance, or other work), whether in whole or in part, and distribute, sell, lease, perform, or broadcast it without the permission of the copyright owner.
- Do not use this product for purposes that could infringe on a copyright held by a third party. We assume no responsibility whatsoever with regard to any infringements of third-party copyrights arising through your use of this product.
- The copyright of content in this product (the sound waveform data, style data, accompaniment patterns, phrase data, audio loops and image data) is reserved by Roland Corporation.
- Purchasers of this product are permitted to utilize said content (except song data such as Demo Songs) for the creating, performing, recording and distributing original musical works.
- Purchasers of this product are NOT permitted to extract said content in original or modified form, for the purpose of distributing recorded medium of said content or making them available on a computer network.
- MMP (Moore Microprocessor Portfolio) refers to a patent portfolio concerned with microprocessor architecture, which was developed by Technology Properties Limited (TPL). Roland has licensed this technology from the TPL Group.
- This product contains eCROS integrated software platform of eSOL Co., Ltd. eCROS is a trademark of eSOL Co., Ltd. in Japan.
- Roland, GS, SuperNATURAL are either registered trademarks or trademarks of Roland Corporation in the United States and/or other countries.
- Company names and product names appearing in this document are registered trademarks or trademarks of their respective owners.

# Contents

## Getting Ready

USING THE UNIT SAFELY ..... 3

IMPORTANT NOTES ..... 5

Placing the RD-800 on a Stand..... 8

Basic Operation..... 9

## Playing the RD-800

Overview of the RD-800 ..... 10

Basic Organization of the RD-800 ..... 10

Units of Sound ..... 10

About Memory ..... 11

Operation Guide..... 12

Adjusting the Overall Volume..... 12

Changing the Sound's Pitch in Real Time (Pitch bend) .... 12

Adding Vibrato or Dynamics (Modulation) ..... 12

Adjusting the Volume Level for Individual Layers..... 12

Assigning Convenient Performance Functions  
([S1] [S2] Buttons) ..... 12

Disabling the Button (Panel Lock)..... 12

Accessing the MENU Screen ..... 12

Accessing the MIDI Control Screen..... 12

Transposing Your Performance (Transpose) ..... 12

Selecting Sounds (Tone/Live Set) ..... 13

Layering Tones (Layer) ..... 13

Dividing the Keyboard into Two Regions (Split) ..... 13

Adding Reverberation to the Sound (REVERB)..... 14

Applying an Effect (MODULATION FX) ..... 14

Applying Tremolo (TREMOLLO) ..... 14

Adjusting the Character of the Sound (TONE COLOR)..... 14

Adjusting the Distortion (AMP SIM) ..... 14

Adjusting the Levels of Each Frequency Range  
(EQUALIZER)..... 15

Adding Delay to the Sound (DELAY) ..... 15

Controlling the Functions Assigned to the Knobs (ASSIGN)15

Effect Signal Flow..... 15

Panel Descriptions..... 16

Top Panel..... 16

Rear Panel (Connecting the External Equipment)..... 18

Turning the RD-800 On ..... 19

Turning the RD-800 Off ..... 19

Listening to the Demo Songs ..... 19

Editing the Sound ..... 20

Uniquely Varying the Sound (Tone Color) ..... 20

Using the Knobs to Adjust the Sound ..... 20

Editing a Live Set (Live Set Edit) ..... 21

Editing a Tone (Designer) ..... 21

Creating the Organ Tones..... 22

Saving the Sound Settings in a Live Set (Live Set Write)... 23

Changing the Order of Live Sets (Live Set Swap)..... 23

Using the Convenient Functions in Performances ..... 24

Playing Rhythm ..... 24

Recording Audio ..... 24

Playing Audio Files from USB Flash Drive..... 25

Various Settings ..... 26

Accessing the Menu Screens..... 26

Controlling an External MIDI Device from the RD-800 .... 26

Formatting Memory (Format)..... 27

Making the Power Automatically Turn Off After a Time  
(Auto Off) ..... 27

Restoring the Factory Settings (Factory Reset) ..... 27

## Setting Up the RD-800

Detailed Settings for a Live Set (Live Set Edit) ..... 28

Detailed Settings for Each Layer (Layer Edit)..... 28

Changing the Key Touch (Key Touch)..... 29

Assigning Functions to Pedals (Pedal) ..... 29

Assigning Functions to ASSIGN 1-5 (Assign 1-5)..... 30

Assigning Functions to the [S1] [S2] Buttons (S1/S2)..... 30

List of Functions Assignable to Pedals, Knobs, and  
Buttons ..... 30

Adding Reverberation to the Sound (Reverb) ..... 31

Adding Spaciousness to the Sound (Delay)..... 31

Detailed Tone Settings (Designer) ..... 32

Piano Designer ..... 32

Tone Designer..... 33

Making Detailed Settings for the E. Piano Tones..... 33

Making Detailed Settings for the CLAV Tones ..... 33

Making Detailed Settings for the Other Tones..... 33

Editing Individual Keys (Individual Note Voicing) ..... 34

Editing the Modulation FX (Modulation FX) ..... 35

Editing Tremolo/Amp Simulator (Tremolo/Amp Simulator)35

Simulating the Creation of Organ Tones..... 36

Before using this unit, carefully read the sections entitled "IMPORTANT SAFETY INSTRUCTIONS" (p. 2), "USING THE UNIT SAFELY" (p. 3), and "IMPORTANT NOTES" (p. 5). These sections provide important information concerning the proper operation of the unit. Additionally, in order to feel assured that you have gained a good grasp of every feature of your new unit, read Owner's Manual in its entirety. This manual should be saved and kept on hand as a convenient reference.

Copyright © 2014 ROLAND CORPORATION

All rights reserved. No part of this publication may be reproduced in any form without the written permission of ROLAND CORPORATION.

<b>Using the RD-800 As a Master Keyboard</b> .....	<b>37</b>
What's MIDI? .....	37
About MIDI Connectors .....	37
Adjusting the Volume of Each Layer.....	37
Selecting the MIDI Connector to Use for Output .....	37
Setting the MIDI Transmit Channel.....	38
Selecting Sounds on an External MIDI Device .....	38
Detailed Settings for Transmitted Parts.....	38
<b>Detailed Settings for Each Function</b> .....	<b>40</b>
Setting Parameters (System) .....	40
Tuning to Other Instruments' Pitches (Master Tune) .	40
Retaining the Equalizer Settings Even When the	
Live Set Is Switched (EQ Mode) .....	40
Retaining the Function Select Button	
Settings Even When the Live Set is Switched	
(Select Button Mode).....	40
Retaining the Pedal Settings Even When the Live	
Set Is Switched (Pedal Mode) .....	40
Retaining the [S1] [S2] Button Settings Even When	
the Live Set Is Switched (S1/S2 Mode) .....	40
Retaining the Assign 1–5 Controller Settings Even	
When the Live Set Is Switched (Assign 1-5 Mode) ...	40
Retaining the Delay Settings Even When the Live	
Set Is Switched (Delay Mode).....	40
Retaining the Reverb Settings Even When the Live	
Set Is Switched (Reverb Mode) .....	41
Retaining the Rhythm Settings Even When the	
Live Set is Switched (Rhythm Mode) .....	41
Retaining the Keyboard Touch Settings Even When	
the Tone or Live Set is Switched (Key Touch Mode) ..	41
Retaining the Current Tone Even When Tones Are	
Switched (Tone/Live Set Remain).....	41
Selecting the USB Driver (USB Driver).....	41
Selecting the USB MIDI Thru Switch	
(USB MIDI Thru Switch) .....	41
Selecting the Function of the MIDI THRU/OUT 2	
Connector (MIDI OUT2 Port Mode) .....	41
Switching the Pedal's Polarity (Damper/FC1/FC2/	
EXT Pedal Polarity) .....	42
Setting the Tuning Method (Temperament/Key) ....	42
Selecting the Parts That Will Produce Sound	
(Part Switch 1–16).....	42
Transmitting Synchronization Messages (Clock Out)	42
Transmitting High-Resolution Velocity Data	
(Hi-Res Velocity Out ) .....	43
Selecting the MIDI Output Port for Rhythm	
(Rhythm MIDI Output Port).....	43
Selecting the MIDI Output Channel for Rhythm	
(Rhythm MIDI Channel) .....	43
Adjusting the Playback Volume of Audio Files .....	43
Adjusting the Brightness of the Display	
(LCD Brightness) .....	43
Settings for Knob LED Illumination	
(Knob LED Switch) .....	43
Changing the Background Image (Display Theme) ..	43
Making the Power Automatically Turn Off After a	
Time (Auto Off) .....	43

Saving System Settings.....	43
Making the System Compressor Settings	
(System Compressor) .....	44
Live Set File Management (Live Set File).....	44
Saving a Live Set File (Live Set File Save) .....	44
Calling Up Live Set Files (Live Set File Load) .....	45
Deleting a Live Set File (Live Set File Delete) .....	46
Copying a Live Set File (Live Set File Copy) .....	46
Convenient Functions (Utility) .....	47
Disconnecting the Controller Section and the	
Sound Generator Section (Local Switch) .....	47
Optimizing Settings for Recording on an External	
Sequencer (Rec Mode) .....	47
Formatting Memory (Format) .....	47
Restoring the Factory Settings (Factory Reset) .....	48
Importing a Specific Live Set from a Live Set File	
(Live Set Import) .....	48
Initializing a Live Set (Live Set Initialize).....	48
About MIDI Visual Control (V-LINK/MVC) .....	49
Turning MIDI Visual Control ON/OFF.....	49
MIDI Visual Control Settings .....	49
Detailed Settings of MIDI Visual Control .....	49
V-LINK/MVC Local Switch.....	50
Wireless LAN Function Settings (Wireless).....	50
Basic Connection Method (Connect by WPS).....	50
Status Indication (Wireless).....	51
Connecting to a Wireless LAN Access Point That	
You Select (Select Access Point) .....	51
Other Settings (Wireless Options) .....	51
Checking the IP Address and MAC Address	
(Wireless Information).....	52

<b>Connecting to Your Computer</b> .....	<b>53</b>
Connecting to a Computer via the USB COMPUTER Port. .	53
Switching USB Drivers .....	53
Using the RD-800 As a USB MIDI Interface.....	53

## Appendix

<b>Troubleshooting</b> .....	<b>54</b>
<b>Error Messages</b> .....	<b>57</b>
<b>Effect List</b> .....	<b>58</b>
<b>Main Specifications</b> .....	<b>59</b>
Anchoring the Power Cord (Cord Clamp).....	59
<b>Index</b> .....	<b>60</b>
<b>List of Shortcut Keys</b> .....	<b>64</b>

# Placing the RD-800 on a Stand

Be careful not to pinch your fingers when setting up the stand.

If you want to place the RD-800 on a stand, use the Roland KS-G8 or KS-G8B.

Place the instrument on the stand as follows.

## KS-G8/KS-G8B

Seen from the side

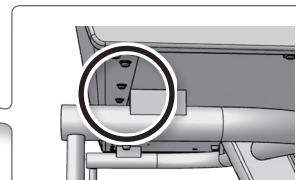
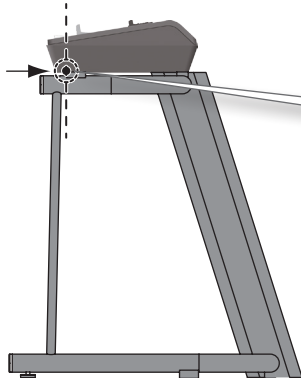

Align the seam in the RD-800's panel (on the bottom, near the front) with the corners of the stand's rubber feet

Seen from the rear

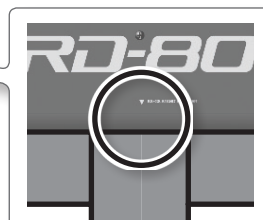
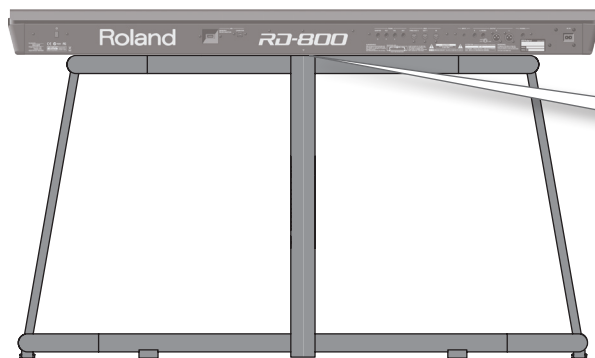

Align the mark on the RD-800's rear panel with the center of the stand

# Basic Operation

\* Illustrations and screen shots included in this document are for the purposes of explaining the functions and operation; they may differ slightly from what you actually see on your instrument.

## Tone screen

This is the screen that appears when you start up the RD-800 or when you press a TONE button.

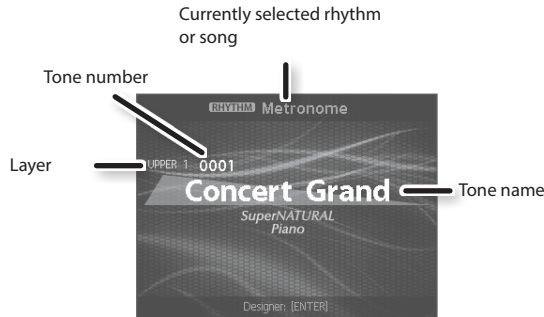

## Live Set screen

This is the screen that appears when you press a LIVE SET button.

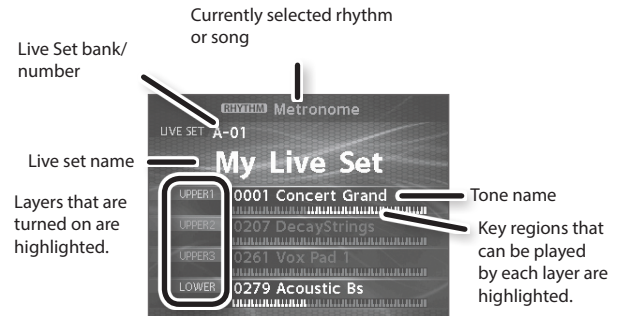

## Navigating among items to be set (cursor)

When more than one parameter is present in a screen, the name and value of the parameter to be changed is shown with a box around it. This box is referred to as the "cursor." The cursor is moved with the Cursor [▲] [▼] [◀] [▶] buttons.

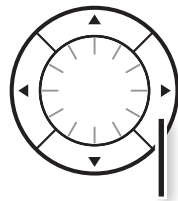
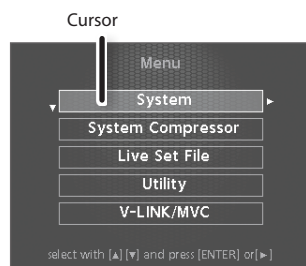

Cursor button

## Knob and slider operations

When you use a knob or slider to modify a setting, the modified parameter and its value appears in a popup screen. This screen will automatically close after a time.

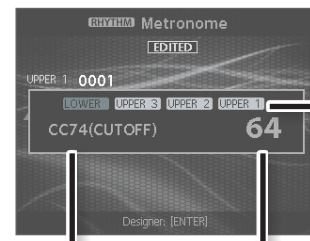

The layer that can be controlled by the knobs and sliders is highlighted.

## Editing a value

When changing settings values, you can use the [DEC] and [INC] buttons, value dial, or the TONE buttons (numeric keys).

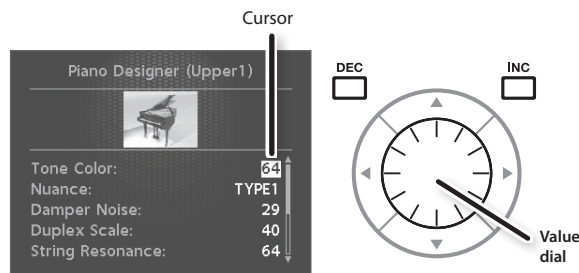

## VALUE dial

Turn the dial clockwise to increase the value, or counterclockwise to decrease the value.

## TONE buttons (numeric keys)

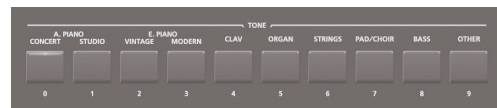

For some settings, you can use the TONE buttons as a numeric keypad of [0]–[9] buttons to specify a numeric value directly. When you enter the number, the value will blink. This indicates that the value has not yet been finalized. To finalize the value, press the [ENTER] button.

## [DEC] button, [INC] button

Pressing the [INC] button increases the value, and the [DEC] button decreases it.

Purpose	Panel operation
To continuously change the value	Hold down the [DEC] button or [INC] button.
To rapidly change the value	While holding down the [INC] button, press the [DEC] button. While holding down the [DEC] button, press the [INC] button.
To set the item to its default value	Press the [DEC] button and [INC] button simultaneously.

# Overview of the RD-800

## Basic Organization of the RD-800

### Controller Section

This section includes the keyboard, the Pitch Bend/Modulation lever, the panel knobs, the sliders, and any pedal connected to the rear panel. Actions such as pressing and releasing of keys on the keyboard, depressing a damper pedal, and so forth, are converted to MIDI messages and sent to the sound generator section, or to an external MIDI device.

### Sound Generator/Effect Section

This is the section that produces and modifies the sound. Performance data from the controller section is converted into audio signal, which is output from the OUTPUT jacks or PHONES jack.

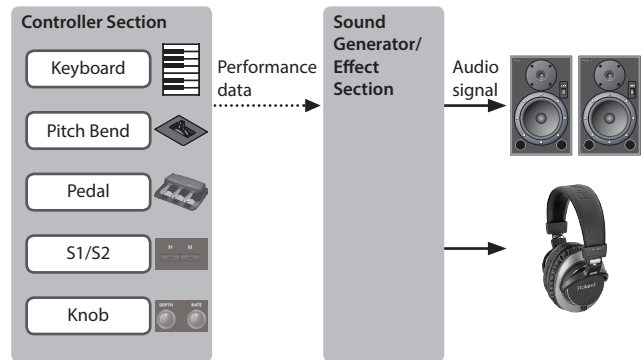

## Units of Sound

### Tone

On the RD-800, each sound selected by a tone button is called a "tone."

To play a tone, you'll assign it to one of the four layers (UPPER 1, UPPER 2, UPPER 3, LOWER). You can play two or more layers simultaneously from the keyboard, or use different regions of the keyboard to play different layers.

You can use the Designer function (p. 32) to adjust the sound to your taste. The adjusted tones can be saved in a Live Set.

Some of the tones are "rhythm sets" which contain multiple percussion instrument sounds.

A rhythm set will produce a different percussion instrument sound for each key (note number) that you press.

### Live Set

On the RD-800, each sound selected by a LIVE SET button is called a "Live Set."

A Live Set consists of settings for a tone assigned to each layer, along with settings that are common to the layers (such as reverb, delay, and EQ). You can store your favorite setups as 200 Live Sets and easily recall them by using the LIVE SET [A]-[J] buttons.

The factory settings include numerous stage-ready Live Sets.

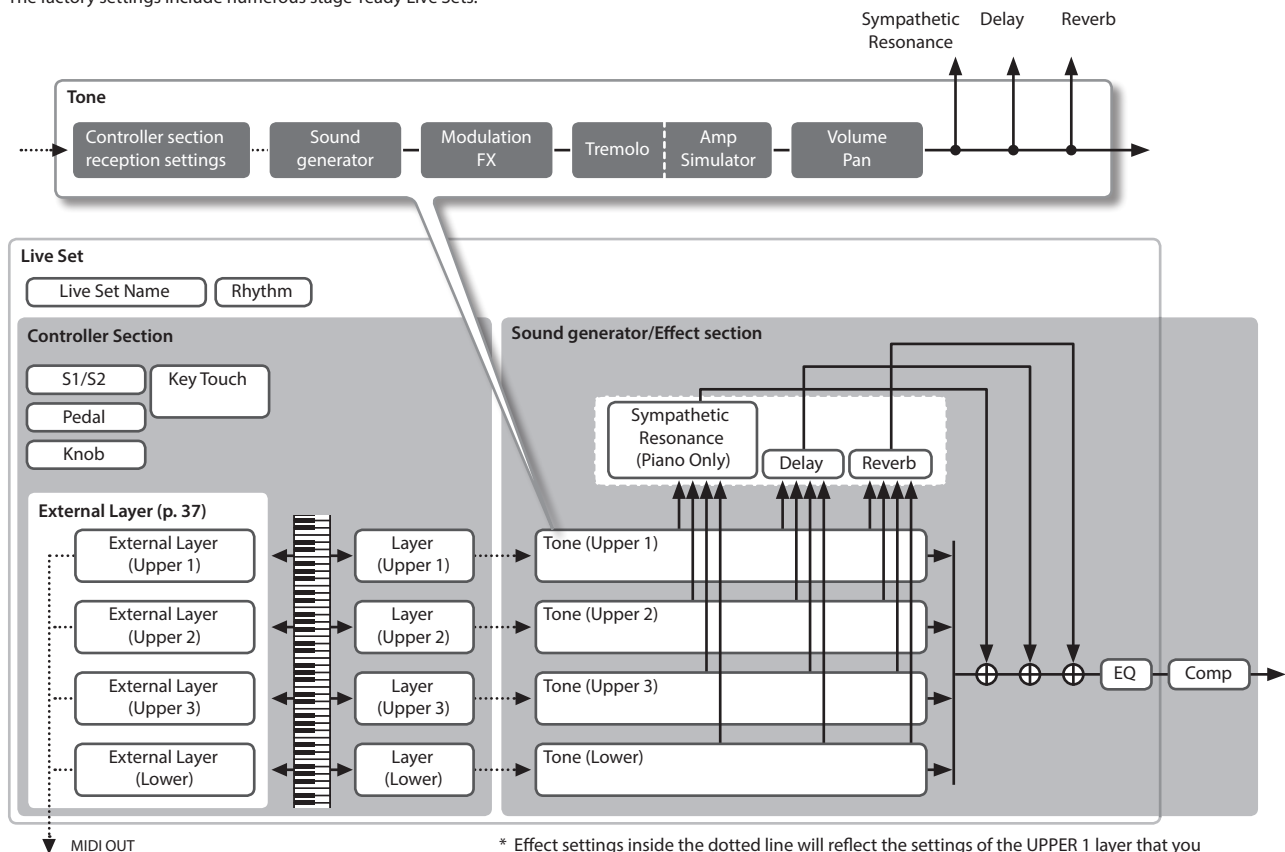

\* Effect settings inside the dotted line will reflect the settings of the UPPER 1 layer that you selected in the TONE screen or the LIVE SET screen.

## About Memory

Memory provides storage locations where Live Sets and other settings are stored. There are three types of memory: “temporary memory,” “rewritable memory,” and “non-rewritable memory.”

### Temporary Memory

#### Temporary area

The sound and controller settings you select using the panel tone buttons or LIVE SET buttons are called into the temporary area.

When you play the keyboard, sounds are produced according to the settings that are in the temporary area.

The settings in the temporary area will be lost when you turn off the power or call up other settings. If you want to keep the data that’s in the temporary area, you must store it into rewritable memory.

### Rewritable Memory

#### System memory

System memory contains system parameter settings that specify how the RD-800 is to operate. To store system parameters, save the system settings (p. 43).

#### User memory

Live Sets and songs can be stored in user memory (LIVE SET Write: p. 23).

You can also save all of the live sets in a single operation (LIVE SET File Save: p. 44).

#### USB flash drive

You can save all of the live sets in a single file (LIVE SET File Save: p. 44).

You can copy Live Set files between a USB flash drive and user memory (Live Set File Copy: p. 46).

The USB flash drive is also used as the storage location for audio recording.

### Non-rewritable Memory

#### Preset memory

The demo songs and the tones are stored in preset memory; they cannot be rewritten.

RD-800

#### Temporary Memory

##### Temporary area

Live Set

#### Rewritable Memory

##### System memory

##### User memory

Live Set

Live Set files

#### Non-rewritable Memory

##### Preset memory

Tone

DEMO songs

#### Rewritable Memory

##### USB flash drive

Live Set files

Audio-recorded data

# Operation Guide

## Adjusting the Overall Volume

1. Turn the [VOLUME] knob.



## Adjusting the Volume Level for Individual Layers

### LAYER Switch

These buttons turn each layer on/off. It is on, unlit is off.

### LAYER LEVEL Slider

Adjusts the volume of an individual layer.

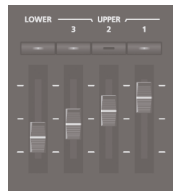

## Accessing the MENU Screen

1. Press the [MENU] button.

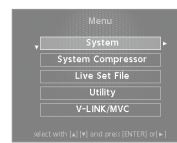

Here you can make system settings for the RD-800, or manage files.

page 26

## Accessing the MIDI Control Screen

1. Press the [MIDI CONTROL] button.

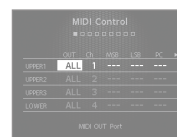

Here you can control the external layers.

page 26

Roland  
RD-800

## Assigning Convenient Performance Functions ([S1] [S2] Buttons)

You can assign various functions to these buttons (p. 30). While performing, you can press these buttons to use the assigned functions.

## Changing the Sound's Pitch in Real Time (Pitch bend)

While playing the keyboard, move the lever to the left to lower the pitch, or to the right to raise the pitch. This is known as Pitch Bend.

If you move the lever away from yourself while also moving it to left or right, the pitch bend and modulation effects will be applied simultaneously.

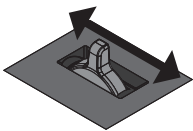

## Adding Vibrato or Dynamics (Modulation)

You can also apply vibrato by manipulating the lever away from you. This is known as Modulation.

If you move the lever away from yourself while also moving it to left or right, the pitch bend and modulation effects will be applied simultaneously.

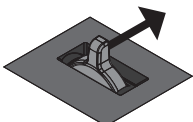

## Disabling the Button (Panel Lock)

By engaging the Panel Lock function, you can disable panel functions.

This prevents settings from being changed inadvertently on stage or in other such situations.

1. While holding down the [MENU] button, press the [ENTER] button.

The panel lock popup screen appears for a time and then disappears; then an icon indicating the panel lock status appears in the upper right of the Tone screen and the Live Set screen.



2. To disengage the Panel Lock function, press the [EXIT/SHIFT] button twice in succession.

## Transposing Your Performance (Transpose)

You can adjust the transpose setting in semitone steps over a range of -48 to +48 relative to C4.

1. Hold down the [TRANPOSE] button for several seconds.

The current setting is shown.

2. Continuing to hold down the [TRANPOSE] button, press the [DEC] [INC] buttons or a key.

When you release the [TRANPOSE] button, the previous screen reappears.

When the amount of transposition is set, the Transpose function switches on, and the [TRANPOSE] button lights up.

### MEMO

- If you press the C4 (middle C) key, the transpose amount will be set to "0." For example, to have "E" sound when you play "C" on the keyboard, hold down the [TRANPOSE] button and press the E4 key. The degree of transposition then becomes "+4."
- You can set the degree of transposition for each of the Layer individually. For details, refer to "TRA (Layer Transpose)" (p. 28).

### NOTE

If the transpose amount is 0, the [TRANPOSE] button will not turn on even if you press it.

### Selecting Sounds (Tone/Live Set)

#### Selecting a Tone

1. Press any of the TONE buttons to select the category.
2. Use the [DEC] [INC] buttons or value dial to select the tone.



#### MEMO

- By holding down the [SHIFT] button and using the [INC] [DEC] buttons or the value dial, you can select the first sound of each tone category.
- By holding down the currently selected TONE button and pressing the [WRITE] button, you can memorize the currently selected tone number, so that it will be recalled the next time you press that TONE button.
- If you switch tones, the function parameters assigned to the knobs will be updated, meaning that the values might not match the positions currently indicated by the knobs.  
If a knob does not match the actual value, moving that knob broadly will cause the value to be updated to the actual position.

#### Selecting a Live Set

1. Press any of the LIVE SET buttons to select the bank (A–J).
2. Use the [DEC] [INC] buttons or value dial to select the Live Set number.



#### MEMO

- By holding down the [SHIFT] button and using the [INC] [DEC] buttons or the value dial, you can select the first sound of each Live Set bank.
- By holding down the currently selected LIVE SET button and pressing the [WRITE] button, you can memorize the currently selected Live Set number, so that it will be selected the next time you press that LIVE SET button.
- If you switch Live Sets, the function parameters assigned to the knobs and sliders will be updated, meaning that the values might not match the positions currently indicated by the knobs and sliders.  
If a knob or slider does not match the actual value, moving that knob or slider broadly will cause the value to be updated to the actual position.

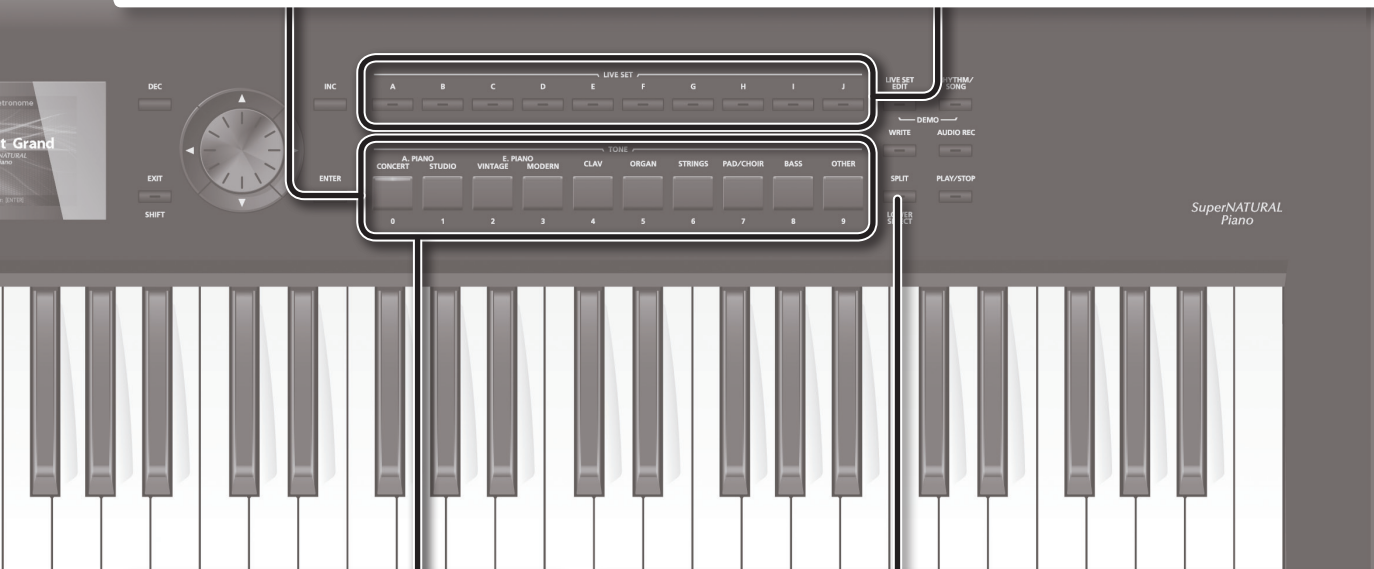

### Layering Tones (Layer)

You can combine sounds using up to four layers (UPPER 1, UPPER 2, UPPER 3, LOWER) according to the order in which you press the tone buttons.

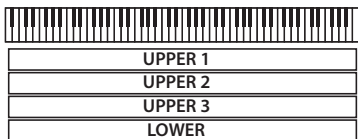

1. Press two, three, or four TONE buttons together in the desired order.

#### Switching a Layer's Tone

1. Press the [LIVE SET EDIT] button to access the Live Set Edit Menu screen.
2. Choose "Layer Edit" and press the [ENTER] button.  
The Layer Edit screen appears.
3. Press the cursor [◀] button several times to access Tone.
4. Use the cursor [▲] [▼] buttons to select the layer whose tone you want to switch.
5. Use the tone buttons to select a tone category, and use the [DEC] [INC] buttons or the value dial to select a tone.

### Dividing the Keyboard into Two Regions (Split)

1. Press the [SPLIT] button, getting the indicator to light.

The UPPER tone plays in the right-hand section of the keyboard, and the LOWER tone plays in the left-hand section.

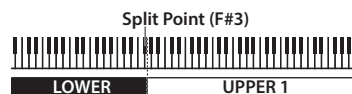

2. To exit Split mode, press the [SPLIT] button once more, and the indicator light goes out.

#### Changing the Keyboard's Split Point

1. While holding down the [SPLIT] button, press the key that is to become the new split point.

The split point is shown.

When you release the [SPLIT] button, the previous display will reappear.

The split-point key is included in the LOWER section.

#### Switching the Lower Layer's Tone

1. Hold down the [SPLIT/LOWER SELECT] button and press the tone button whose tone you want to switch.

The number and name of the sound that's currently selected for the Lower layer will be displayed.

2. Continuing to hold down the [SPLIT/LOWER SELECT] button, use the [DEC] [INC] buttons or the value dial to select a tone.

#### MEMO

You can freely set whatever key ranges you like to each layer. For details, refer to "LWR (Key Range Lower)" (p. 28), "UPR (Key Range Upper)" (p. 28).

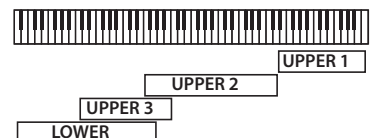

### Adding Reverberation to the Sound (REVERB)

Applying reverb adds pleasing reverberation to what you play, so it sounds almost as if you were playing in a concert hall.

1. Use the [REVERB] knob to adjust the amount of reverb effect to be applied.

**NOTE**

When the LAYER EDIT's "REV (Reverb Send Level)" setting is set to "0," then no effect is applied, even when the [REVERB] knob is turned (p. 28).

**MEMO**

If you hold down the [SHIFT] button and turn the [REVERB] knob, the Reverb screen appears.

In the Reverb screen, you can edit the reverb type and other reverb-related parameters (p. 31).

### Adjusting the Character of the Sound (TONE COLOR)

Turning the TONE COLOR knob will modify an aspect of the sound, such as its character or acoustic image.

1. Use the [TONE COLOR] knob to adjust the amount of effect.

page 20

**MEMO**

- You can use the [WRITE] button to save the adjusted sound to the Live Set.
- You can assign the effect of the [TONE COLOR] knob to a pedal (p. 29).

\* You can control the tone of the layer for which "TON CLR (Tone Color Control Destination)" has a check mark in the layer settings (LAYER EDIT) (p. 28).

Roland  
**RD-800**

VOLUME

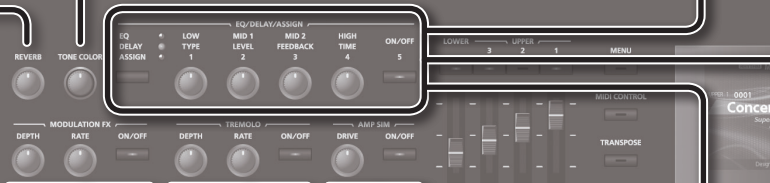

### Applying an Effect (MODULATION FX)

The RD-800 lets you apply a wide variety of effects, including modulation-type effects.

The two knobs of the MODULATION FX section are assigned to control the most useful parameters of each effect.

1. In the MODULATION FX section, make the [ON/OFF] button light.  
The effect will turn on/off each time you press the button.
2. In the MODULATION FX section, turn the [DEPTH] and [RATE] knobs to adjust the effect.



**Switching the Modulation FX Type**

1. While holding down the MODULATION FX [ON/OFF] button, use the [INC] [DEC] buttons or turn the value dial.

For a list of the effects that can be used in modulation FX, refer to "Effect List" (p. 58). For details on the effect parameters, refer to "Effect Parameter Guide" (PDF).

\* You can control the tone of the layer for which "MOD FX (Modulation FX Control Destination)" has a check mark in the layer settings (LAYER EDIT) (p. 28).

### Applying Tremolo (TREMOL)

You can adjust the rate and depth of the tremolo effect.

1. In the TREMOL section, make the [ON/OFF] button light.  
The tremolo will turn on/off each time you press the button.
2. In the TREMOL section, turn the [DEPTH] and [RATE] knobs to adjust the tremolo.



**Switching the Tremolo Type and the Amp SIM Type**

1. While holding down the TREMOL [ON/OFF] button or the AMP SIM [ON/OFF] button, press the [INC] [DEC] buttons or turn the value dial.

For the available types of tremolo and amp simulator, refer to "Editing Tremolo/Amp Simulator (Tremolo/Amp Simulator)" (p. 35).

For more about tremolo and amp simulator, refer to "Effect Parameter Guide" (PDF). For details on how to obtain the PDF, refer to "Obtaining PDF Manuals" on the front cover.

\* You can control the tone of the layer for which "TR/AMP (Tremolo/Amp Control Destination)" has a check mark in the layer settings (LAYER EDIT) (p. 28).

### Adjusting the Distortion (AMP SIM)

You can adjust the amount of distortion.

1. In the AMP SIM section, make the [ON/OFF] button light.  
The amp simulator will turn on/off each time you press the button.
2. In the AMP SIM section, turn the [DRIVE] knob to adjust the amount of distortion.



### Adjusting the Levels of Each Frequency Range (EQUALIZER)

The RD-800 is equipped with a five-band equalizer.

1. Press the EQ/DELAY/ASSIGN function select button to make the EQ indicator light.
2. Press the [ON/OFF] button to make the indicator light.
3. Turn the knobs to adjust the levels in each range.

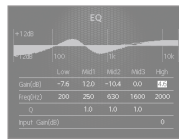

Hold down the [SHIFT] button and turn a knob toward the left to lower the frequency; turn the knob toward the right to raise the frequency.

#### NOTE

Sounds may be distorted with certain knob settings. If this occurs, adjust the Input Gain.

#### MEMO

- The Mid3 band cannot be controlled from the knobs. To change the Mid3 setting, move the cursor to Mid3 and use the value dial to adjust it.
- You can set the RD-800 so that the equalizer settings are not changed when you change Live Sets. Refer to "Retaining the Equalizer Settings Even When the Live Set Is Switched (EQ Mode)" (p. 40).
- For details, refer to "Effect Parameter Guide" (PDF). For details on how to obtain the PDF, refer to "Obtaining PDF Manuals" on the front cover.

### Adding Delay to the Sound (DELAY)

By adding the delay effect, you can give the sound greater dimension, with more fatness and breadth.

1. Press the EQ/DELAY/ASSIGN function select button to make the DELAY indicator light.
2. Press the [ON/OFF] button to make the indicator light.



The delay effect will turn on/off each time you press the button.

3. Turn each of the DELAY knobs to adjust the character of the delay effect.

#### NOTE

If the layer setting (LAYER EDIT) "DLY (Delay Send Level)" is set to 0, no effect will be applied even if you turn the DELAY knobs (p. 28).

#### MEMO

- If you hold down the [SHIFT] button and turn one of the DELAY knobs, the Delay screen appears. In this Delay screen you can adjust the delay-related parameters (p. 31).
- If you hold down the [SHIFT] button and press the [ON/OFF] button located at the right of the EQ/DELAY/ASSIGN knob, the Layer Edit screen appears with the cursor positioned at the Delay Send Level value.

### Controlling the Functions Assigned to the Knobs (ASSIGN)

Here's how you can adjust parameters that you've assigned to the knobs or the button.

1. Press the EQ/DELAY/ASSIGN function select button to make the ASSIGN indicator light.
2. Turn the ASSIGN [1]-[4] knobs to adjust the functions that you've assigned to the knobs.

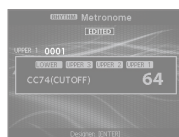

Press the ASSIGN [5] button to switch the effect of the function you've assigned to the button.

#### Assigning Functions to the Knobs

1. Press the EQ/DELAY/ASSIGN function select button to make the ASSIGN indicator light.
2. Hold down the [SHIFT] button and turn one of the ASSIGN [1]-[4] knobs. The Assign1-5 screen appears. Here you can specify the functions that are assigned to the ASSIGN [1]-[4] knobs and the ASSIGN [5] button (p. 30).
3. Hold down the [SHIFT] button and press the ASSIGN [5] button. The Layer Edit screen appears. You can specify the layers that will be controlled by the ASSIGN [1]-[4] knobs and the ASSIGN [5] button (p. 28).

#### NOTE

Operating the ASSIGN knobs or ASSIGN [5] button will have no effect on layers for which the layer setting (LAYER EDIT) "A1-A5 (Assign 1-5 Control Switch)" check box is not selected (p. 28).

#### MEMO

Depending on the state of the selected Live Set or tone, the assigned function might not be supported, so that you might not obtain the effect you expect.

### Effect Signal Flow

#### Reverb

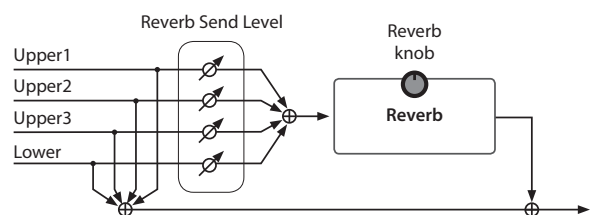

#### Delay

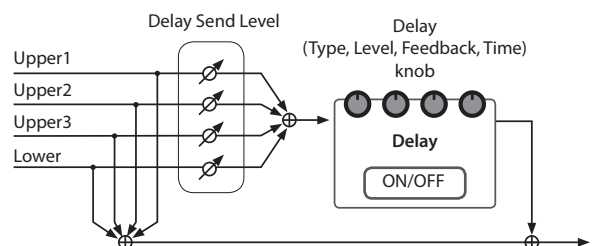

# Panel Descriptions

## Top Panel

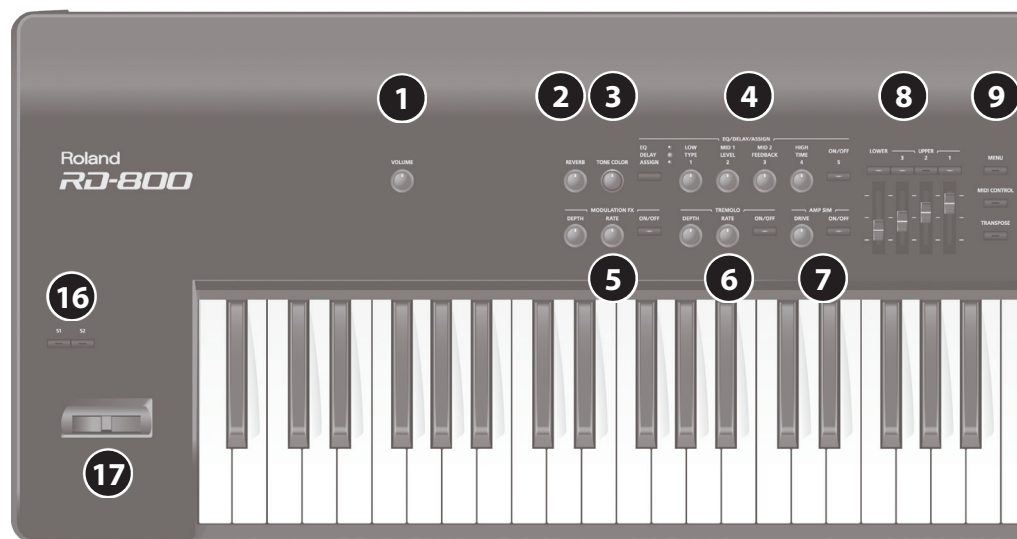

### 1 [VOLUME] knob

Adjusts the overall volume of the RD-800.

### 2 [REVERB] knob

Adjusts the amount of reverb.

page 14

### 3 [TONE COLOR] knob

Adjusts the tonal character or sonic image.

page 14

### 4 EQ/DELAY/ASSIGN

page 15

#### Function select button

Press this button repeatedly to cycle through EQ, DELAY, and ASSIGN.

#### [1] [2] [3] [4] knobs

Adjust the value of the selected function (EQ, DELAY, ASSIGN).

#### [5] button

Turns the selected function (EQ, DELAY) on/off.

Controls the selected function (ASSIGN).

### 5 MODULATION FX

page 14

#### [DEPTH] knob

Adjusts the depth of the modulation FX.

#### [RATE] knob

Adjusts the rate of the modulation FX.

#### [ON/OFF] button

Turns the effect on/off.

#### NOTE

For some modulation FX types, "DEPTH" and "RATE" will control different things.

### 6 TREMOLO

page 14

#### [DEPTH] knob

Adjusts the depth of the tremolo effect.

#### [RATE] knob

Adjusts the rate of the tremolo effect.

#### [ON/OFF] button

Turns the effect on/off.

### 7 AMP SIM

page 14

#### [DRIVE] knob

Adjusts the amount of distortion.

#### [ON/OFF] button

Turns the effect on/off.

### 8 Layer

#### LAYER switch

Turns each LAYER's sound on and off.

page 12

#### LAYER LEVEL sliders

Adjusts the volume level for each layer.

If the [MIDI CONTROL] button is lit, these sliders adjust the volume of each external layer.

page 12

### 9

#### [MENU] button

Accesses the MENU screen. In the MENU screen, you can make overall settings for the entire RD-800.

page 26

#### [MIDI CONTROL] button

Puts the RD-800 in control of the external MIDI sound generator.

page 26

#### [TRANPOSE] button

Lets you transpose your performance.

page 12

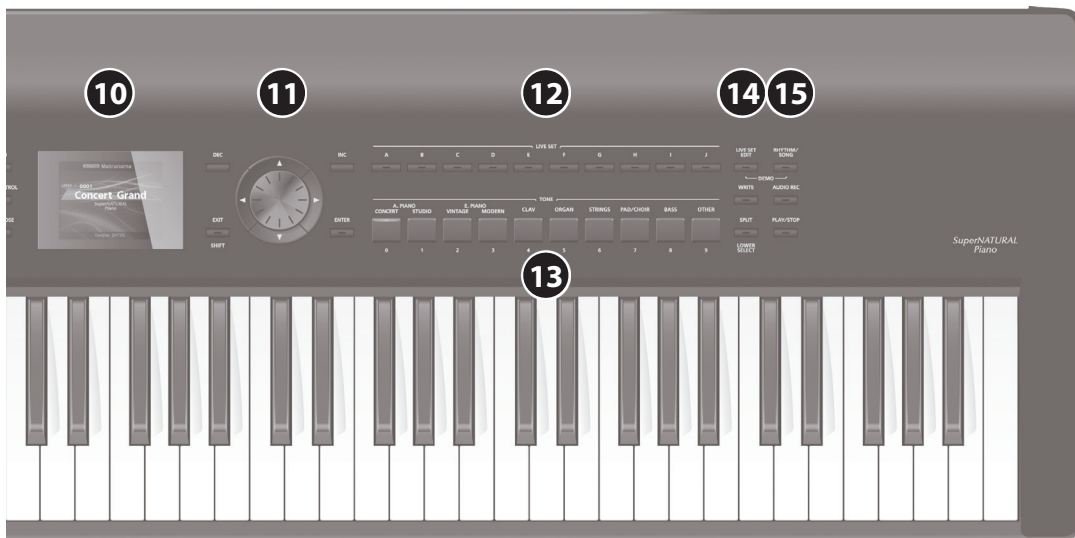

## 10 Display

This shows the Tone name, the Live Set names and the values of various settings, etc.

\* The explanations in this manual include illustrations that depict what should typically be shown by the display. Note, however, that your unit may incorporate a newer, enhanced version of the system (e.g., includes newer sounds), so what you actually see in the display may not always match what appears in the manual.

## 11 Cursor buttons/Value dial

### [DEC] button, [INC] button

These are used to modify values.

If you keep on holding down one button while pressing the other, the value change accelerates.

### Value dial

This is used to modify values.

### Cursor [▲] [▼] [◀] [▶] buttons

Press these to switch pages and to move the cursor.

### [EXIT/SHIFT] button

Pressed to return to a previous screen or to cancel a procedure.

Additionally, you can easily call up Edit screens for related parameters by holding down this button while pressing buttons, turning knobs, or operating other controllers. For details, refer to "List of Shortcut Keys" (p. 64).

If you edit a parameter value while holding down this button, the value will change more greatly.

### [ENTER] button

This is used to finalize a value or execute an operation.

## 12 LIVE SET buttons

Select Live Sets in each bank.

page 13

## 13 TONE buttons

Select tones in each category.

page 13

## 14

### [LIVE SET EDIT] button

page 21

This allows you to change the Live Set settings.

In addition, you can listen to the demo songs by simultaneously pressing this button and the [RHYTHM/SONG] button.

### [WRITE] button

page 23

Stores the current settings to "Live Set."

In certain screens (such as the System screen), pressing this button will store the system parameters (p. 43).

### [SPLIT/LOWER SELECT] button

page 13

This button selects "Split mode," whereby the keyboard is divided into two regions, allowing you to play separate sounds with the right and left hands.

## 15 Rhythm/Song

### [RHYTHM/SONG] button

page 24

Accesses a screen where you can select songs or rhythms.

In addition, you can listen to the demo songs by simultaneously pressing this button and the [LIVE SET EDIT] button.

### [AUDIO REC] button

page 24

This is the record button. It allows you to record your performance on the RD-800.

### [PLAY/STOP] button

page 25

Start/stops playback of the song or rhythm.

## 16 [S1] button, [S2] button

page 30

You can assign various functions to these buttons. While performing, you can press these buttons to use the assigned functions.

## 17 Pitch bend/Modulation lever

page 12

This allows you to control pitch bend or apply vibrato.

### NOTE

The effect of moving the lever will differ depending on the tone. The effect of this lever is fixed for each tone, and cannot be changed.

## Rear Panel (Connecting the External Equipment)

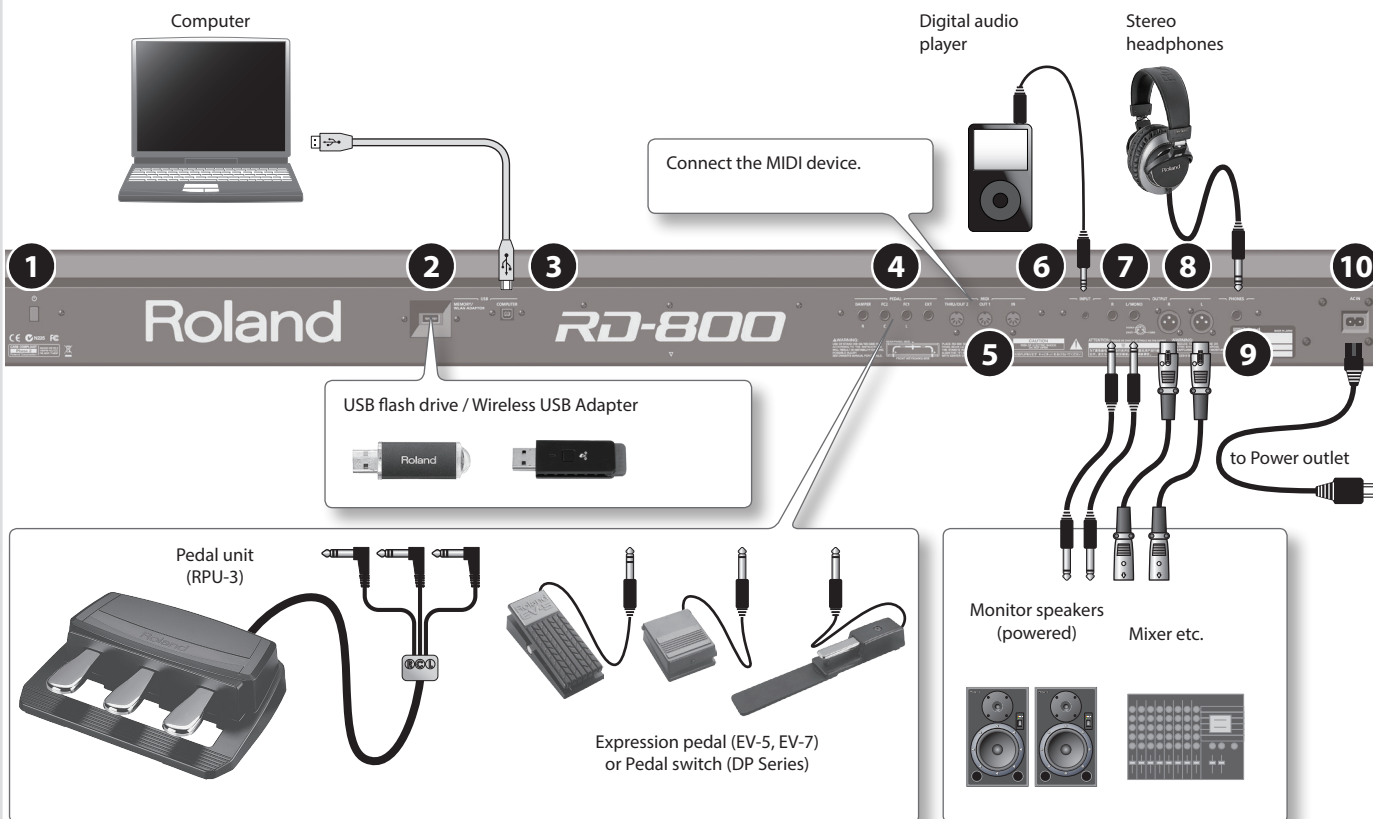

### 1 [ON] switch

This switch turns the unit on/off.

page 19

### 2 USB MEMORY/WLAN ADAPTOR port

Connect separately sold USB flash drive or a Wireless USB Adapter here.

Use USB flash drive or a Wireless USB Adapter sold by Roland.

### 3 USB COMPUTER port

page 53

You can connect this to your computer so that it can exchange performance data with the RD-800.

### 4 PEDAL jacks (DAMPER, FC1, FC2, EXT)

Connecting the pedal switch provided with the RD-800 to the DAMPER jack allows you to use the switch as a damper pedal.

With a pedal connected to the FC1, FC2 or EXT jack, you can then assign a variety of functions to the pedal (p. 29).

### 5 MIDI connectors (IN, OUT 1, THRU/OUT 2)

Used for connecting external MIDI devices and for transmission of MIDI messages.

The THRU/OUT 2 connector's function can be switched to operate either as MIDI THRU or as MIDI OUT (p. 41).

### 6 INPUT jack

This is an audio input jack. You can connect your digital audio player or other audio source here.

### 7 OUTPUT jacks (L/MONO, R)

Provide output of the audio signals. These are connected to an amp or other device. For monaural output, use the L/MONO jack.

### 8 OUTPUT jacks (L, R) (XLR type)

Connectors for balanced output of the audio signals. Connect to mixers and other such gear.

\* This instrument is equipped with balanced (XLR) type jacks. Wiring diagrams for these jacks are shown below. Make connections after first checking the wiring diagrams of other equipment you intend to connect.



### 9 PHONES jack

A set of headphones can be connected to this jack.

Even when headphones are connected, audio signals will still be output from the OUTPUT jacks and BALANCED OUT jacks.

### 10 AC IN jack

Connect the included power cord to this connector.

\* To prevent malfunction and equipment failure, always turn down the volume, and turn off all the units before making any connections.

\* Use only the specified expression pedal (EV-5 or EV-7; sold separately). By connecting any other expression pedals, you risk causing malfunction and/or damage to the unit.

## Turning the RD-800 On

Once everything is properly connected, be sure to follow the procedure below to turn on their power. If you turn on equipment in the wrong order, you risk causing malfunction or equipment failure.

### 1. Turn down the volume of the RD-800.

Also completely turn down the volume of any connected external devices.

### 2. Press the [⏻] switch.

The unit is turned on, and the display's backlighting comes on.

### 3. Turn on the power to connected external devices.

\* This unit is equipped with a protection circuit. A brief interval (a few seconds) after turning the unit on is required before it will operate normally.

### 4. Adjust the volume of the connected external devices.

### 5. Adjust the RD-800's volume.

## Turning the RD-800 Off

### 1. Turn down the volume of the RD-800.

Also completely turn down the volume of any connected external devices.

### 2. Turn off the power to connected external devices.

### 3. Press the [⏻] switch.

The unit is turned off.

\* Before turning the unit on/off, always be sure to turn the volume down. Even with the volume turned down, you might hear some sound when switching the unit on/off. However, this is normal and does not indicate a malfunction.

\* If you need to turn off the power completely, first turn off the unit, then unplug the power cord from the power outlet. Refer to "To completely turn off power to the unit, pull out the plug from the outlet" (p. 3).

## If you don't want the power to turn off automatically, change the "Auto Off" setting to "Off"

The power to this unit will be turned off automatically after a predetermined amount of time has passed since it was last used for playing music, or its buttons or controls were operated (Auto Off function).

If you do not want the power to be turned off automatically, disengage the Auto Off function (p. 27).



### NOTE

- Any settings that you are in the process of editing will be lost when the power is turned off. If you have any settings that you want to keep, you should save them beforehand.
- To restore power, turn the power on again.

## Listening to the Demo Songs

The RD-800 features the internal demo songs that exhibit the special capabilities of the instrument.

### NOTE

- All rights reserved. Unauthorized use of this material for purposes other than private, personal enjoyment is a violation of applicable laws.
- No data for the music that is played will be output from MIDI OUT connectors.
- When you enter demo mode, various settings will be set to their power-on state. If you want to keep your current settings, save them to a Live Set (p. 23).
- The RD-800's keyboard will not produce sound while the demo songs are playing.

### 1. Hold down the [LIVE SET EDIT] button and press the [RHYTHM/SONG] button.

The Demo screen appears.

### 2. Use the cursor buttons to select a demo song.

### 3. Press the [ENTER] button; the demo songs will play.

### 4. Press the [ENTER] button to stop a demo song during playback.

Pressing the [EXIT/SHIFT] button while the song is stopped will take you back to the original screen.

# Editing the Sound

## Uniquely Varying the Sound (Tone Color)

1. Use the [TONE COLOR] knob to adjust an effect that's appropriate for each sound, such as tonal character or sonic image.

### MEMO

- The popup indication will differ depending on the effect.
- When you select a tone or Live Set, the settings will return to the Tone Color default values of each tone.
- When you select a tone or Live Set, the values currently indicated by the knobs might not match the actual values. In this case, moving the knob broadly will cause the displayed value to be updated.

### NOTE

For layer sounds whose layer setting (LAYER EDIT) "TON CLR (Tone Color Control Destination)" is not checked, turning the [TONE COLOR] knob will not apply an effect (p. 28).

### MEMO

The adjusted sound can be saved in the Live Set by pressing the [WRITE] button (p. 23).

### Main Effects for Tone Color

#### Stereo Width & Pan Key Follow



Changes the stereo position or width.

#### Morphing

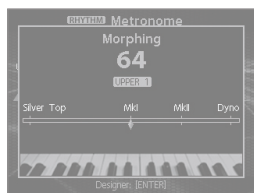

Changes the tonal character.

#### Boost

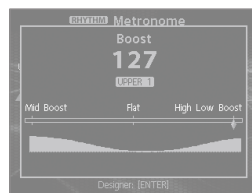

Changes the brightness of the sound.

#### Harmonic Bar

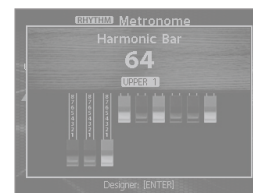

Lets you pull out all of the harmonic bars using a single knob. If you continue turning the knob after all of the harmonic bars are pulled out, the rotary effect will switch to the fast state (p. 22).

## Using the Knobs to Adjust the Sound

The RD-800 lets you easily adjust the sound to your taste.

Here's an actual example that shows the steps of adjusting the sound of the RD-800 and the features that are available.

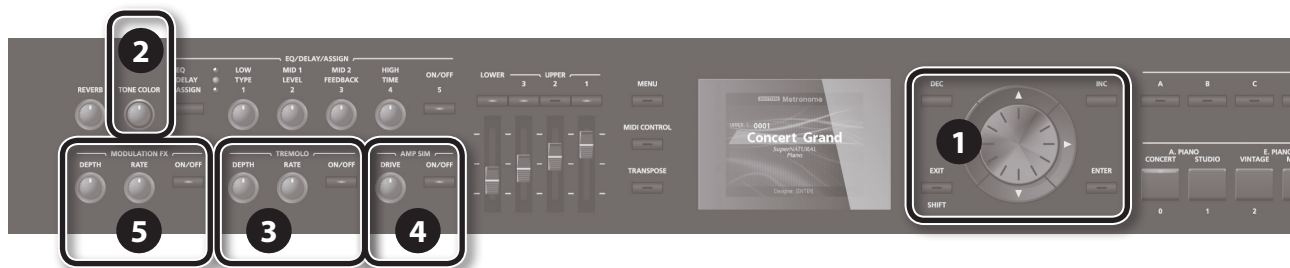

1. In the Tone screen (p. 9), use the [DEC] [INC] buttons or value dial to select the tone 0069 "TINE E.Piano."

A pleasant-sounding electric piano tone with a mellow feel often used in pop or jazz is selected.

2. Turn the [TONE COLOR] knob all the way to the left, and then slowly turn it toward the right.

The character of the sound changes; the attack will initially be soft, but this will gradually become harder, finally transforming into a very brilliant sound. Adjust the character to your taste.

3. Adjust the tremolo effect that modulates the sound between left and right.

Turning the TREMOLO [RATE] knob changes the speed at which the sound moves between left and right.

Turning the TREMOLO [DEPTH] knob changes the amount by which the sound moves between left and right. Adjust the tremolo as appropriate for the song you're playing.

If you don't want tremolo, turn the TREMOLO [ON/OFF] button off to make it go dark.

4. Press the AMP SIM [ON/OFF] button to turn it on and make it light; then turn the AMP SIM [DRIVE] knob.

Turning the knob toward the right adds distortion to the sound.

Although you're free to make the sound distort intensely, you might want to add just a bit of distortion as a subtle edge.

5. Press the MODULATION FX [ON/OFF] button to turn it on and make it light.

This lets you apply an effect.

Use the MODULATION FX [RATE] knob and MODULATION FX [DEPTH] knob to adjust the settings to your taste.

You can also switch the MODULATION FX type by holding down the MODULATION FX [ON/OFF] button and using the [DEC] [INC] buttons or the VALUE dial.

6. When you've adjusted the sound to your liking, save it as a Live Set.

### Live Set Write

Next time, you can simply select the saved Live Set and immediately start playing the sound that you adjusted to your taste.

## Editing a Live Set (Live Set Edit)

1. Press the [LIVE SET EDIT] button.  
The Live Set Edit Menu screen appears.
2. Use the cursor buttons to select the item that you want to edit, and press the [ENTER] button.  
The edit screen for that item appears.
3. Select the parameter that you want to edit, and use the [DEC] [INC] buttons or the value dial to edit the value.  
Press the [EXIT/SHIFT] button to return to the Live Set Edit Menu screen.
4. Repeat steps 2–3 to continue editing.
5. When you've finished making settings, press the [EXIT/SHIFT] button several times to return to the Tone screen or the Live Set screen.



### NOTE

If you've edited the settings, an "EDITED" indication is shown in the Live Set screen or the Tone screen.

If you turn off the power, select another Live Set, or select another tone in the Tone screen while the "EDITED" indication is shown, the edits you made are discarded. If you want to keep your edits, press the [WRITE] button to save the Live Set (p. 23).

### Live Set Edit Menu

- Layer Edit** .....  
Edits the settings of each layer (Upper 1–3, Lower). **page 28**
- Key Touch** .....  
Edits the keyboard touch sensitivity. **page 29**
- Pedal** .....  
Edits the pedal settings. **page 29**
- Assign 1-5** .....  
Assign the function of the ASSIGN [1]–[4] knobs and the ASSIGN [5] button. **page 30**
- S1/S2** .....  
Edits the [S1] [S2] switch settings. **page 30**
- Reverb** .....  
Edits the reverb settings. **page 31**
- Delay** .....  
Edits the delay settings. **page 31**

## Editing a Tone (Designer)

By using the Designer function, you can make more detailed settings for a tone.

1. While holding down the [SHIFT] button, press the LAYER switch to which the tone you want to edit is assigned.  
The Designer Menu screen (in the case of TW-Organ sounds, the Tone Wheel & Designer Menu screen) of the selected layer appears.  
In the Designer menu you'll choose the broad category of tone settings that you want to edit.



### MEMO

If you press the [ENTER] button in the Tone screen, the UPPER 1 Designer Menu screen (p. 32) appears.

2. Use the cursor buttons to select the item that you want to edit, and press the [ENTER] button.  
The edit screen for that item appears.

### MEMO

The items that you can set will differ depending on the type of sound.

### NOTE

If you've edited the settings, an "EDITED" indication is shown in the Live Set screen or the Tone screen.

If you turn off the power, select another Live Set, or select another tone in the Tone screen while the "EDITED" indication is shown, the edits you made are discarded. If you want to keep your edits, press the [WRITE] button to save the Live Set (p. 23).

### Designer Menu

- Piano Designer (only for certain piano sounds)** .....  
Lets you create your own personalized piano sound by adjusting various aspects of a piano's tonality. **page 32**
- Tone Designer (other than certain piano sounds)** .....  
Edits detailed settings of the piano sound. The editable parameters will depend on the piano sound that is selected. **page 33**
- Individual Note Voicing (only for certain piano sounds)** .....  
Edits the pitch, volume, and character of each key. **page 34**
- Sympathetic Resonance (only for certain piano sounds)** .....  
Edits the sympathetic resonances that are heard when you hold down the damper pedal. **page 35**
- Modulation FX** .....  
Edits parameters that are related to Modulation FX. **page 35**
- Tremolo/Amp Simulator** .....  
Edits parameters that are related to tremolo and amp simulator. **page 35**

## Creating the Organ Tones

Some organ feature nine “harmonic bars” that can be drawn in and out, and by using the bars in different combinations of positions, a variety of different tones can be created. Different “Feet” are assigned to each bar, with the pitches of the sounds being determined by these “Feet.”

You can create of tones using the Layer LEVEL sliders just as you operate the harmonic bars.

### What Are “ Feet?”

Feet basically refers to the lengths of pipe used in pipe organs. The length of pipe used to produce the reference pitch (the fundamental) for the keyboard is eight feet. Reducing the pipe to half its length produces a pitch one octave higher; conversely, doubling the pipe length creates a pitch one octave lower. Therefore, a pipe producing a pitch one octave below that of the reference of 8’ (eight feet) would be 16’; for one octave above the reference, the pipe would be 4’, and to take the pitch up yet another octave it would be shortened to 2’.

#### NOTE

These settings are available only when a TW-Organ sound is selected.

1. While holding down the [SHIFT] button, press the layer switch to which the TW-Organ sound you want to edit is assigned.

The Tone Wheel & Designer Menu screen of the selected layer appears.

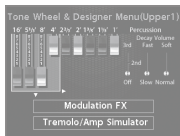

#### MEMO

If a TW-Organ sound is selected as the Upper 1, you can also access the Tone Wheel & Designer Menu screen by pressing the [ENTER] button from the Tone screen.

2. If you move the LAYER LEVEL sliders, the sound will change in tandem with the screen display.

You can use the cursor [◀] [▶] buttons to switch between harmonic bar and percussion switch groups.

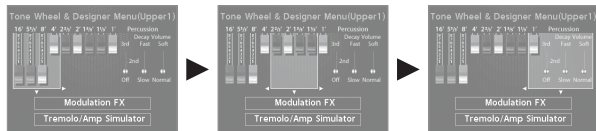

#### MEMO

Percussion adds a sound with a sense of attack at the beginning of the note, giving the sound a crisper feel. The attack sound will change depending on this value.

Parameter	Value	Explanation
Percussion Switch	OFF	No percussion is added.
	2nd	Percussion sounds at a pitch one octave above that of the key pressed.
	3rd	Percussion sounds at a pitch an octave and a fifth above that of the key pressed.
Percussion Decay	Slow	The percussion's attenuation time is lengthened. This softens the sense of attack.
	Fast	The percussion sound decays more quickly. This gives more of a sense of attack for a sharp sound.
Percussion Volume	Soft	The percussion sound is diminished, and the harmonic bars produce their normal volume.
	Normal	The percussion sound will be at its normal volume, and the sound of the harmonic bars is diminished.

#### NOTE

When percussion is on, the 1’ pitch will not be produced.

#### MEMO

- You can also use the cursor [▲] [▼] buttons to move the cursor to the Modulation FX or Tremolo/Amp Simulator menu items.
- When the cursor is located at Modulation FX or Tremolo/Amp Simulator, you can go to the corresponding item by pressing the [ENTER] button. Refer to “Editing the Modulation FX (Modulation FX)” (p. 35) and “Editing Tremolo/Amp Simulator (Tremolo/Amp Simulator)” (p. 35).
- When a TW-Organ sound is selected, turning the [TONE COLOR] knob will move all of the harmonic bars simultaneously.

### Changing the Undulation of the Organ Tone (Rotary Effect)

While the Tone Wheel & Designer Menu screen is displayed, you can change the undulation rate of the Rotary effect with the Pitch Bend lever.

The Rotary effect is an effect that recreates the sound of the rotating speakers used to augment the sound of an organ.

Moving the pitch bend lever to left or right will toggle the Rotary effect between fast and slow regardless, of the direction in which you move the lever.

#### MEMO

This Pitch Bend Lever setting is effective only in the Tone Wheel screen.

## Saving the Sound Settings in a Live Set (Live Set Write)

1. Press the [WRITE] button, getting the indicator to light.  
The Live Set Write screen appears.
2. Use the cursor [◀] [▶] buttons to move the cursor to the position at which you want to enter a character.
3. Use the [DEC] [INC] buttons or the value dial to enter the characters.



Operation	Explanation
[SHIFT] + [◀] button	Delete one character (DELETE)
[SHIFT] + [▶] button	Insert one space (INSERT)
[SHIFT] + [▲] button	Switch character sets
[SHIFT] + [▼] button	Switch uppercase/lowercase

4. Repeat steps 2–3 to input the name.
5. Press the cursor [▼] button to move the cursor to the destination Live Set number.
6. Select the save-destination Live Set number, either by using the [DEC] [INC] buttons or the value dial.
7. When you have finished determining the save destination and the name for the new Live Set, press the [ENTER] button.  
The confirmation message appears.
8. When the [ENTER] button is pressed, saving of the Live Set begins.

### NOTE

Never switch off the power while "Executing..." appears in the display.

### Specifying the sound selected at startup (STARTUP)

The RD-800 lets you specify the state (sound) in which it will power-on.

1. Select the desired sound.

#### Selecting a Tone

page 13

#### Selecting a Live Set

page 13

2. Press the [WRITE] button.  
The Live Set Write screen appears.
3. Move the cursor to the Live Set bank/number.
4. Press the [DEC] button several times or turn the value dial toward the left to select STARTUP.
5. Press the [ENTER] button.  
The confirmation message appears.
6. Press the [ENTER] button.



The current setting will be saved to STARTUP.

The next time you start the RD-800, it will start up with the STARTUP condition (sound) that you saved.

## Changing the Order of Live Sets (Live Set Swap)

You can arrange the Live Sets into the order you like. It is convenient to arrange Live Sets in the order in which you'll be using them for your live performance.

1. Select a Live Set whose order you want to change (p. 13).
2. While holding down the [SHIFT] button, press one of the LIVE SET [A]–[J] buttons to select the bank that contains the other Live Set whose order you want to change.  
LIVE SET SWAP screen appears.

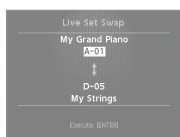

### NOTE

You can't use the Live Set Swap function in the following situations.

- If the Live Set screen shows the "EDITED" icon.
- If a tone is selected by the tone buttons.
- In the Menu screen, Write screen, or Demo screen.
- When RHYTHM, AUDIO PLAY, or AUDIO REC are operating.

### MEMO

You can also access this screen from the Utility screen (p. 47) by moving the cursor to "Live Set Swap" and pressing the [ENTER] button.

3. You can use the [INC] [DEC] buttons, value dial, and LIVE SET [A]–[J] buttons to change the swap-destination Live Set.  
You can also use the cursor to select the swap-source Live Set, and change it to a different Live Set.

### MEMO

- You can also select STARTUP.
- When you play the keyboard, you'll hear the sound of the Live Set that's selected by the cursor.

4. Press the [ENTER] button.  
The confirmation message appears.
5. Press [ENTER] button to execute the swap.  
You can repeat steps 3–5 to change the order of other Live Sets.  
If you decide to cancel Live Set Swap, press the [EXIT/SHIFT] button.

### MEMO

In this case, the originally-selected Live Set number will be selected.

### NOTE

Never switch off the power while "Executing..." appears in the display.

# Using the Convenient Functions in Performances

## Playing Rhythm

1. Press the [RHYTHM/SONG] button, getting the indicator to light.

The Song or Rhythm screen appears.

Each time you press the [RHYTHM/SONG] button, you'll alternate between the Song screen and the Rhythm screen.

2. Press the [RHYTHM/SONG] button several times to access the Rhythm screen.
3. Press the [PLAY/STOP] button, getting the indicator to light.

The rhythm will begin playing.

To stop the rhythm, press the [PLAY/STOP] button so its indicator is off.

### NOTE

While the rhythm is playing, pressing the [SONG/RHYTHM] button will not switch to the SONG screen.



### Changing the Rhythm Pattern

1. In the Rhythm screen, move the cursor to the rhythm number in the screen.
2. Use the [DEC] [INC] buttons or value dial to change the patterns.

For more about the rhythm patterns, refer to "Sound List" (PDF). For details on how to obtain the PDF, refer to "Obtaining PDF Manuals" on the front cover.

### MEMO

A recommended drum kit will be selected for each rhythm pattern.

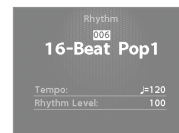

### Changing the Rhythm Tempo or Volume

1. In the Rhythm screen, move the cursor to Tempo or Rhythm Volume.
2. Use the [DEC] [INC] buttons or the value dial to adjust the tempo or rhythm volume.

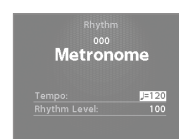

## Recording Audio

### Connecting the USB Flash Drive

1. Connect your USB flash drive (sold separately) to the USB MEMORY/WLAN ADAPTOR port located on the back of the RD-800.

### Preparing to Record

### NOTE

Do not disconnect the USB flash drive during audio recording. Doing so may cause all the data in the USB flash drive to be lost.

1. Select the tone or Live Set that you want to play (p. 13).
2. Press the [AUDIO REC] button to enter the record-standby state.

If the rhythm was sounding, it will stop. The [AUDIO REC] button will light, and the [PLAY/START] button will blink.

If you want to cancel recording, press the [AUDIO REC] button.

### Start Recording

1. Press the [PLAY/STOP] button.  
The [PLAY/STOP] button will light, and recording will start.

### Stop Recording

1. Press the [PLAY/STOP] button.

Recording will stop, and the recorded data will be saved on the USB flash drive.

Recording will also stop if you press the [AUDIO REC] button.

### Recorded audio file format

File Extension	WAV
Sampling Frequency	44.1 kHz
Bit Depth	16-bit

### Auditioning the Recorded Data

1. Press the [PLAY/STOP] button to audition the song you recorded.  
Press the [PLAY/STOP] button once again to stop playback.

## About USB flash drives

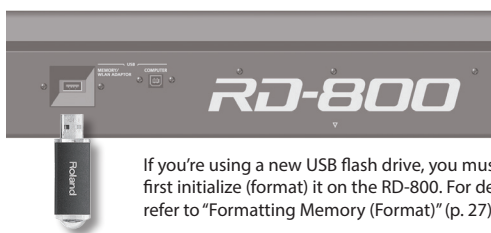

If you're using a new USB flash drive, you must first initialize (format) it on the RD-800. For details, refer to "Formatting Memory (Format)" (p. 27).

### NOTE

- Never insert or remove a USB flash drives while this unit is turned on. Doing so may corrupt the unit's data or the data on the USB flash drives.
- Carefully insert the USB flash drive all the way in—until it is firmly in place.
- Use USB flash drives available from Roland. Proper operation cannot be guaranteed if other USB devices are used.

## Playing Audio Files from USB Flash Drive

### MEMO

- If the USB flash drive contains numerous song files, it may take some time for the data to be loaded.
- Use single-byte alphanumeric characters for the file name.
- A maximum of 200 files can be recognized within each folder.

### WAV format files that can be played

Sampling Frequency	44.1 kHz
Bit Depth	16-bit

\* Changing the Play Speed or Playback Transpose of an audio file places a significant processing load on the RD-800; in some cases this could make the RD-800 unable to completely process the performance data from the keyboard.

### Playing Back

1. Press the [RHYTHM/SONG] button, getting the indicator to light.

The Rhythm or Song screen appears.

Each time you press the [RHYTHM/SONG] button, you'll alternate between the RHYTHM screen and the SONG screen.

2. Press the [RHYTHM/SONG] button several times to access the Song screen.
3. Press the [PLAY/STOP] button to make it light; the audio file will play.

Press the [PLAY/STOP] button once again to make it go dark; the audio file will stop playing.

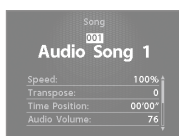

### NOTE

If an audio file is playing, pressing the [RHYTHM/SONG] button will not switch to the Rhythm screen.

### Selecting an Audio File

1. In the Song screen, move the cursor to the song number in the screen.
2. Use the [DEC] [INC] buttons or the value dial to select a song number.

If there is no playable song, the song number will be shown as "—" and the [INC] [DEC] buttons will not work.

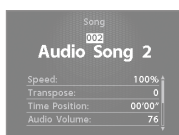

### Selecting an Audio File in a Folder

1. Use the [DEC] [INC] buttons or the value dial to select a folder.
2. Press the [ENTER] button.
3. Use the [DEC] [INC] buttons or the value dial to select an audio file.

To exit the folder, choose "up" and press the [ENTER] button.

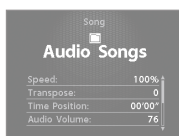

### MEMO

- Use single-byte alphanumeric characters for the file name.
- A maximum of 200 files can be recognized within each folder.

### Fast-forwarding or Rewinding an Audio File

1. In the Song screen, move the cursor to the Time Position.
2. Use the [DEC] [INC] buttons or the value dial to change the value.

The playback position will change according to the indication.

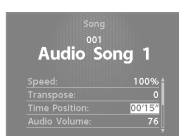

### Changing How Audio Files Play

1. In the Song screen, move the cursor to the various items.
2. Use the [DEC] [INC] buttons or the value dial to change the value.

Parameter	Value	Explanation
Play Speed	75%–125%	Lets you change the playback speed of the song.
Playback Transpose	-6–0–+5	Lets you shift the playback key of a song in semitone steps.
Audio Volume	0–127	Sets the volume for audio file playback.
Center Cancel	OFF, ON	Causes sounds located in the center (e.g., vocals or melodic instruments) to be reduced in volume.
Play Mode	ONE SONG	When you play back a song, only one song will play; playback will stop at the end of that song.
	ALL SONG	The songs in USB flash drive will play consecutively.

### Renaming an Audio File

1. In the Song screen, choose "Song Rename" and press the [ENTER] button.
2. Use the cursor [◀] [▶] buttons to move the cursor to the position at which you want to enter a character.
3. As necessary, use the [DEC] [INC] buttons or the value dial to enter a name.

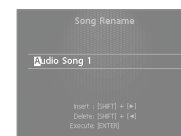

Operation	Explanation
[SHIFT] + [◀] button	Delete one character (DELETE)
[SHIFT] + [▶] button	Insert one space (INSERT)
[SHIFT] + [▲] button	Switch character sets
[SHIFT] + [▼] button	Switch uppercase/lowercase

### NOTE

You can't save an audio file with a name that starts with a "." (period)." Do not use a "." (period)" at the beginning of the name.

4. Repeat steps 2–3 to enter the name.  
If you press the [EXIT/SHIFT] button, the rename operation will be cancelled and you'll return to the previous screen.
5. Press the [ENTER] button.  
The confirmation message appears.
6. Press the [ENTER] button once again to confirm the name of the song.

### Deleting an Audio File

1. In the Song screen, choose "Song Delete" and press the [ENTER] button.  
The confirmation message appears.
2. Press the [ENTER] button.  
The song will be deleted.

### NOTE

- Never turn off the power while deletion is in progress.
- Do not disconnect the USB flash drive while deletion is in progress.

# Various Settings

## Accessing the Menu Screens

### Setting Parameters

1. Press the [MENU] button.
2. Use the cursor buttons to select the item that you want to edit, and press the [ENTER] button.  
The corresponding edit screen appears.
3. Select the parameter that you want to edit, and use the [DEC] [INC] buttons or the value dial to edit the value.
4. When you've finished making settings, press the [EXIT/SHIFT] button several times to return to the Tone screen or the Live Set screen.

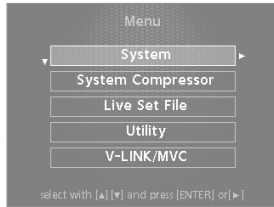

### MEMO

The following settings will be stored as common settings for the entire RD-800 when you press the [WRITE] button in an edit screen.

- System
- System Compressor
- V-LINK/MVC

However, following settings are not saved.

- MIDI VISUAL CONTROL On or Off

### Editable items

**System** page 40

Make settings that affect the operating environment of the entire RD-800.

**System Compressor** page 44

Make settings for the stereo compressor (limiter) that is applied to the final output.

**Live Set File** page 44

Manage Live Set files and songs.

**Utility** page 47

Make settings that specify how your RD-800 performance will be recorded on an external sequencer, or initialize the RD-800 itself or a USB flash drive.

**V-LINK/MVC** page 49

Make settings for MIDI Visual Control.

**Wireless** page 50

Confirm and modify the wireless settings.

## Controlling an External MIDI Device from the RD-800

By connecting an external MIDI device to the MIDI OUT connectors on the RD-800's rear panel, you can then control the external MIDI device from the RD-800.

1. Press the [MIDI CONTROL] button, getting the indicator to light.  
Use the layer switches to specify whether MIDI data for each of the external layers will be transmitted from the MIDI OUT connector.  
Use the layer level sliders to adjust the volume of the external layers.



### Editable items

**MIDI connector for output** page 37

For each layer you can select the MIDI OUT connector or USB COMPUTER port from which its data is to be transmitted.

**MIDI transmit channel** page 38

Specify the RD-800's MIDI transmit channel.

**Sound selection** page 38

Specify how the RD-800 will select sounds on an external MIDI device.

**Detailed settings for transmit parts** page 38

Specify how the RD-800 will control the external MIDI device.

## Formatting Memory (Format)

“Formatting” is an operation by which you can erase all Live Set files from user memory or initialize a USB flash drive to a state in which it can be used with the RD-800.

USB flash drive cannot be used with the RD-800 unless it is formatted suitably for the RD-800.

Before using a new USB flash drive, you’ll need to format it.

### NOTE

When you format the USB flash drive, all data previously saved on that memory will be erased. Before you carry out a format, make sure that the USB flash drive does not contain important data you need to keep.

1. Press the [MENU] button, select “Utility,” and press the [ENTER] button.
2. Choose “Format” and press the [ENTER] button.
3. Use the [DEC] [INC] buttons or the value dial to select the media that you want to format.

Parameter	Explanation
USER MEMORY	All Live Set files will be erased from the RD-800’s user memory.
USB MEMORY	The USB flash drive connected to the rear panel USB MEMORY/WLAN ADAPTOR port will be formatted.

4. Press the [ENTER] button.  
If you decide to cancel the Format operation, press the [EXIT/SHIFT] button.
5. Press the [ENTER] button once again to execute the Format operation.

### NOTE

- Never turn off the unit while the screen indicates “Executing...”
- Don’t disconnect the USB flash drive until formatting is completed.

## Making the Power Automatically Turn Off After a Time (Auto Off)

1. Press the [MENU] button, select “System,” and press the [ENTER] button.

The System screen appears.

2. Choose “Auto Off,” and change the setting.

Value	Explanation
Off	The power will not turn off automatically.
30 min	The power will automatically turn off if no operation is performed for 30 minutes.
240 min (default)	The power will automatically turn off if no operation is performed for 240 minutes (4 hours).

3. To store the auto-off setting, press the [WRITE] button in the System screen.

### NOTE

If the auto-off function turns the power off, the various settings that you had been editing will be lost. Be sure that you’ve saved any settings that you want to keep.

For how to save the settings, refer to “Saving the Sound Settings in a Live Set (Live Set Write)” (p. 23), or “Saving System Settings” (p. 43).

### To Turn the Power On Again After It Was Turned Off by “Auto-Off”

When turning the unit’s power back on after it has been shut down due to the Auto Off function, always make sure to allow at least ten seconds to pass after the power has been shut off before you turn the power back on. If you turn it back on too rapidly, the Auto Off function will not have had enough time to reset itself, and you may not be able to turn on the power in the normal way.

## Restoring the Factory Settings (Factory Reset)

The settings stored in the RD-800 can be returned to their factory settings.

1. Press the [MENU] button, choose “Utility,” and press the [ENTER] button.
2. Choose “Factory Reset Current” or “Factory Reset All.”

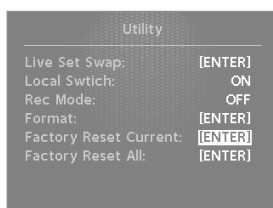

Parameter	Explanation
Factory Reset Current	The currently selected Live Set returned to their factory settings.
Factory Reset All	All Live Sets and system settings in the RD-800 will return to their factory-set state.

3. Press the [ENTER] button.  
The Factory Reset screen appears.
4. Press the [ENTER] button.  
The confirmation message appears.
5. Press the [ENTER] button once again to start the Factory Reset operation.

If you chose “Factory Reset Current,” you will return to the previous screen. If you chose “Factory Reset All,” turn the power of the RD-800 off, and then on again.

### NOTE

Never turn off the power during Factory Reset (while “Executing... Don’t Power OFF” appears in the display).

# Detailed Settings for a Live Set (Live Set Edit)

Here's how to make detailed settings for the four layers of a Live Set.

## 1. Press the [LIVE SET EDIT] button.

The Live Set Edit Menu screen appears.

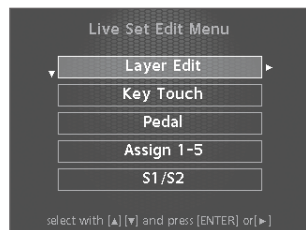

## 2. Use the cursor [▲] [▼] buttons to select the item you want to edit, and press the [ENTER] button.

The corresponding edit screen appears.

## 3. Select the parameter that you want to edit, and use the [DEC] [INC] buttons or the value dial to edit the value.

If you press the [EXIT/SHIFT] button, you'll return to the Live Set Edit Menu screen.

## 4. When you've finished making settings, press the [EXIT/SHIFT] button several times to return to the Tone screen or the Live Set screen.

### NOTE

If you've edited the settings, an "EDITED" indication is shown in the Live Set screen or the Tone screen.

If you turn off the power, select another Live Set, or select another tone in the Tone screen while the "EDITED" indication is shown, the edits you made are discarded. If you want to keep your edits, press the [WRITE] button to save the Live Set (p. 23).

## Detailed Settings for Each Layer (Layer Edit)

Here's how to edit each layer (Upper 1-3, Lower).

## 1. In the Live Set Edit Menu screen, select "Layer Edit" and press the [ENTER] button.

## 2. Select the parameter that you want to edit, and use the [DEC] [INC] buttons or the value dial to edit the value.

Parameter	Value	Explanation
<b>TONE</b>		Selects the tone.
<b>VOL</b> Volume	0-127	Sets the volume for each of the layers.
<b>PAN</b> Pan	L64-0-R63	Specifies the left/right position of the sound when outputting in stereo.
<b>REV</b> Reverb Send Level	0-127	Specifies the level of signal sent to reverb.
<b>DLY</b> Delay Send Level	0-127	Specifies the level of signal sent to delay.
<b>TRA</b> Layer Transpose	-48-0-+48	Allows you to individually transpose layers to a different pitch.
<b>KR.LWR</b> Keyboard Range Lower	A0-C8	Set the keyboard range in which each Layer will sound. This can be used to make notes in different areas of the keyboard play different Tones. Specify the lower limit (KR.LWR) and upper limit (KR.UPR) of the key range being set. You can also set this by pressing a specific key and then pressing the [ENTER] button.
<b>KR.UPR</b> Keyboard Range Upper		* This is effective only when the [SPLIT] button is on (p. 13) in the key range settings. * "Full" is displayed when the [SPLIT] button is set to OFF.

Parameter	Value	Explanation
<b>VR.LWR</b> Velocity Range Lower	1-127	Specifies the lower limit (VR.LWR) and upper limit (VR.UPR) of the range in which the tone is played according to the velocity. Make this setting when you want the tone to change depending on the key velocity.
<b>VR.UPR</b> Velocity Range Upper		
<b>V.SNS</b> Velocity Sensitivity	-63-+63	This setting determines how the volume changes in response to the velocity. The volume is increased as the keyboard is played with greater force when a positive value is used; when a negative value is selected, the volume decreases as the keys are played with greater force. * This setting is disregarded with certain tones.
<b>V.MAX</b> Velocity Max	1-127	Maximum velocity value for the corresponding key. Lowering this value will produce softer notes even if you play the keyboard strongly. * This setting is disregarded with certain tones.
<b>C.TUNE</b> Coarse Tune	-48-+48	Adjusts the pitch in semitone steps (+/-4 octaves).
<b>F.TUNE</b> Fine Tune	-50-+50	Adjusts the pitch in one-cent steps (+/-50 cents). 1 cent = 1/100th of a semitone
<b>VC RES</b> Voice Reserve	0-63, Full	Specifies the number of voices that will be reserved for each layer if you attempt to play more than 128 voices.
<b>DAMP</b> Damper Control Switch	ON, OFF	Specifies whether the damper pedal will (ON) or will not (OFF) control each layer.
<b>FC1</b> FC1 Control Switch		Specifies whether the pedal connected to the FC1 jack will (ON) or will not (OFF) control each layer. (*1)
<b>FC2</b> FC2 Control Switch		Specifies whether the pedal connected to the FC2 jack will (ON) or will not (OFF) control each layer. (*1)
<b>EXT</b> EXT Pedal Control Switch		Specifies whether the pedal connected to the EXT jack will (ON) or will not (OFF) control each layer. (*1)
<b>PB</b> Pitch Bend Control Switch	ON, OFF	Specifies whether the pitch bend lever will (ON) or will not (OFF) control each layer.
<b>MD</b> Modulation Control Switch		Specifies whether the modulation lever will (ON) or will not (OFF) control each layer.
<b>S1</b> S1 Control Switch		Specifies whether the [S1] button will (ON) or will not (OFF) control each layer. (*1)
<b>S2</b> S2 Control Switch		Specifies whether the [S2] button will (ON) or will not (OFF) control each layer. (*1)
<b>A1</b> Assign 1 Control Switch		Specifies whether the ASSIGN [1] knob will (ON) or will not (OFF) control each layer. (*1)
<b>A2</b> Assign 2 Control Switch	Specifies whether the ASSIGN [2] knob will (ON) or will not (OFF) control each layer. (*1)	
<b>A3</b> Assign 3 Control Switch	ON, OFF	Specifies whether the ASSIGN [3] knob will (ON) or will not (OFF) control each layer. (*1)
<b>A4</b> Assign 4 Control Switch		Specifies whether the ASSIGN [4] knob will (ON) or will not (OFF) control each layer. (*1)
<b>A5</b> Assign 5 Control Switch		Specifies whether the ASSIGN [5] button will (ON) or will not (OFF) control each layer. (*1)
<b>TON CLR</b> Tone Color Control Destination	Select one layer	Select the layer that you want to control using the [TONE COLOR] knob.
<b>MOD FX</b> Modulation FX Control Destination		Select the layer that you want to control using the MODULATION FX [DEPTH] and [RATE] knobs and [ON/OFF] button.
<b>TR/AMP</b> Tremolo/Amp Control Destination		Select the layer that you want to control using the TREMOLO [DEPTH] and [RATE] knobs and [ON/OFF] button, and the AMP SIM [DRIVE] knob and [ON/OFF] button.

\*1 The parameters that can control each layer are the parameters indicated by (\*1) in the "List of Functions Assignable to Pedals, Knobs, and Buttons" (p. 30).

## Changing the Key Touch (Key Touch)

The setting below allows you to adjust the response you get from the keyboard when you finger the keys.

1. In the Live Set Edit Menu screen, select “Key Touch” and press the [ENTER] button (p. 28).
2. Select the parameter that you want to edit, and use the [DEC] [INC] buttons or the value dial to edit the value.

Parameter	Value	Explanation
Key Touch	SUPER LIGHT	An even lighter setting than LIGHT.
	LIGHT	Sets the keyboard to a light touch. You can achieve fortissimo (ff) play with a less forceful touch than MEDIUM, so the keyboard feels lighter. This setting makes it easy to play, even for children.
	MEDIUM	Sets the keyboard to the standard touch. You can play with the most natural touch. This is the closest to the touch of an acoustic piano.
	HEAVY	Sets the keyboard to a heavy touch. You have to finger the keyboard more forcefully than MEDIUM in order to play fortissimo (ff), so the keyboard touch feels heavier. Dynamic fingering adds even more feeling to what you play.
	SUPER HEAVY	An even heavier setting than HEAVY.
Key Touch Offset	-10→+9	This setting provides even more precise adjustment of the key touch than available with the Key Touch setting alone. The touch sensitivity becomes heavier as the value increases. When this parameter is set to a value that exceeds the upper or lower limit, the setting for Key Touch (one of five possible values) is automatically changed to accommodate the value you've specified.
Velocity	REAL	Volume levels and the way sounds are played change in response to the velocity.
	1→127	Regardless of how strongly you play the keyboard, volume levels and the way sounds are played always reflect the fixed velocity value you specify here.
Velo Delay Sens	-63→+63	As the value is decreased, the timing of the sound is delayed more when more force is used to play the keys. As the value is increased, the timing of the sound is delayed more when less force is used to play the keys.
Velo Key Follow Sens	-63→+63	As the value is increased, the touch becomes heavier in the upper registers, and lighter in the lower registers.
Key Off Position	STANDARD	Note-off occurs at the key depth of a conventional piano.
	DEEP	Note-off occurs at a deeper position. This is suitable for electric piano sounds.

## Assigning Functions to Pedals (Pedal)

This setting determines the function of the pedal switches (such as the optional DP series) or expression pedals (such as the optional EV-5/7) that are connected to the FC1, FC2, and EXT jacks on the rear panel.

1. In the Live Set Edit Menu screen, select “Pedal” and press the [ENTER] button (p. 28).
2. Select the parameter that you want to edit, and use the [DEC] [INC] buttons or the value dial to edit the value.

### FC1/FC2/EXT pedals

Parameter	Value	Explanation
Func (Function)		Selects the function to be assigned to each pedal. * For details on the values, refer to “List of Functions Assignable to Pedals, Knobs, and Buttons” (p. 30).
Range Min	0→127	Specifies the value that the assigned function will have when the corresponding pedal is not pressed (*1).
Range Max	0→127	Specifies the value that the assigned function will have when the corresponding pedal is fully pressed (*1).

#### MEMO

By specifying the Range Min/Max settings, you'll be able to control the function in the desired range; this will help you obtain the performance result that you want.

- \*1 Depending on the function that's assigned, the function might not be expressed as a value in the range of 0–127. In such cases, the value of 0–127 will be converted to the appropriate range for the assigned function.

### Assigning Functions to ASSIGN 1–5 (Assign 1-5)

Here's how to assign functions to the ASSIGN [1]–[4] knobs and the ASSIGN [5] button.

1. In the Live Set Edit Menu screen, select "Assign 1-5" and press the [ENTER] button (p. 28).
2. Select the parameter that you want to edit, and use the [DEC] [INC] buttons or the value dial to edit the value.

#### ASSIGN [1]–[4] knobs

Parameter	Value	Explanation
Func (Function)	Selects the functions that are assigned to the ASSIGN [1]–[4] knobs. * For details on the values, refer to "List of Functions Assignable to Pedals, Knobs, and Buttons" (p. 30).	
Range Min	0–127	Specifies the value that the assigned function is to have when the corresponding ASSIGN [1]–[4] knob is turned all the way to the left (*1)
Range Max	0–127	Specifies the value that the assigned function is to have when the corresponding ASSIGN [1]–[4] knob is turned all the way to the right (*1).

#### MEMO

By specifying the Range Min/Max settings, you'll be able to control the function in the desired range; this will help you obtain the performance result that you want.

- \*1 Depending on the function that's assigned, the function might not be expressed as a value in the range of 0–127. In such cases, the value of 0–127 will be converted to the appropriate range for the assigned function.

#### ASSIGN [5] button

Parameter	Value	Explanation
Func (Function)	Selects the function that's assigned to the ASSIGN [5] button. * For details on the values, refer to "List of Functions Assignable to Pedals, Knobs, and Buttons" (p. 30).	
Switch Type		Specifies the operation of the button.
	LATCH	The function turns on/off each time you press the button.
	MOMENTARY	The function is on only while you hold down the button.

#### MEMO

Whether the Switch Type setting does anything or not depends on the function that's assigned.

### Assigning Functions to the [S1] [S2] Buttons (S1/S2)

This setting determines the function of the [S1] and [S2] buttons.

1. In the Live Set Edit Menu screen, select "S1/S2" and press the [ENTER] button (p. 28).
2. Select the parameter that you want to edit, and use the [DEC] [INC] buttons or the value dial to edit the value.

#### [S1] [S2] buttons

Parameter	Value	Explanation
Func (Function)	Selects the function that's assigned to the [S1] [S2] buttons. * For details on the values, refer to "List of Functions Assignable to Pedals, Knobs, and Buttons" (p. 30).	
Switch Type		Specifies the operation of the button.
	LATCH	The function turns on/off each time you press the button.
	MOMENTARY	The function is on only while you hold down the button.

#### MEMO

Whether the Switch Type setting does anything or not depends on the function that's assigned.

### List of Functions Assignable to Pedals, Knobs, and Buttons

Controllers to which a function can be assigned			Functions that can be assigned	Explanation
FC1 / FC2 / EXT pedal	ASSIGN [1]–[4] knob	ASSIGN [5] [S1] [S2] button		
✓	✓	✓	OFF	Nothing is controlled.
✓	✓	✓	CC0–CC127	Controller number 0–127 (*1)
✓	---	✓	BEND DOWN	Lowers the pitch just as when the pitch bend lever is moved to the left. (*1)
✓	---	✓	BEND UP	Raises the pitch just as when the pitch bend lever is moved to the right. (*1)
✓	✓	✓	AFTERTOUCH	Controls aftertouch. (*1)
✓	---	✓	OCTAVE DOWN	Lowers the key range in octave steps each time you press the button (maximum four octaves).
✓	---	✓	OCTAVE UP	Raises the key range in octave steps each time you press the button (maximum four octaves).
✓	---	✓	EXT START/STOP	Starts/stops an external sequencer.
✓	---	✓	TAP TEMPO	Sets the tempo to match the timing you use when pressing the pedal or the button.
✓	---	✓	PLAY/STOP	The same function as the [PLAY/STOP] button.
✓	---	✓	SONG RESET	Returns to the beginning of the song.
---	---	✓	SONG BWD	Rewinds the song.
---	---	✓	SONG FWD	Fast-forwards the song.
✓	---	---	MOD FX SWITCH	The same function as the [MODULATION FX [ON/OFF]] button. (*2)

Controllers to which a function can be assigned			Functions that can be assigned	Explanation
FC1 / FC2 / EXT pedal	ASSIGN [1]–[4] knob	ASSIGN [5] [S1] [S2] button		
✓	✓	---	MOD FX DEPTH	The same function as the MODULATION FX [DEPTH] knob. (* 2)
✓	✓	---	MOD FX RATE	The same function as the MODULATION FX [RATE] knob. (* 2)
✓	---	---	TREMOLO SWITCH	The same function as the TREMOLO [ON/OFF] button. (* 3)
✓	✓	---	TREMOLO DEPTH	The same function as the TREMOLO [DEPTH] knob. (* 3)
✓	✓	---	TREMOLO RATE	The same function as the TREMOLO [RATE] knob. (* 3)
✓	---	---	AMP SIM SWITCH	The same function as the AMP SIM [ON/OFF] button. (* 3)
✓	✓	---	AMP SIM DRIVE	The same function as the AMP SIM [DRIVE] knob. (* 3)
✓	---	---	DELAY SWITCH	Turns Delay (p. 15) on/off.
✓	---	✓	ROTARY SPEED	When using the rotary effect, switches the rotary effect between fast and slow.
✓	---	---	tone COLOR	The same function as the [TONE COLOR] knob. (* 4)
✓	---	✓	LIVE SET DOWN	Switches Live Sets in descending order.
✓	---	✓	LIVE SET UP	Selects Live Sets in ascending order.

- \* 1 You can specify the layer (or external layer) to which the assigned function will apply. “Detailed Settings for Each Layer (Layer Edit)” (p. 28), “Detailed Settings for Transmitted Parts” (p. 38).
- \* 2 You can specify the assigned function for the layer that’s selected in “MOD FX (Modulation FX Control Destination)” (p. 28).
- \* 3 You can specify the assigned function for the layer that’s selected in “TR/AMP (Tremolo/Amp Control Destination)” (p. 28).
- \* 4 You can specify the assigned function for the layer that’s selected in “TON CLR (Tone Color Control Destination)” (p. 28).

**MEMO**

Depending on the state of the selected Live Set or tone, the assigned function might not be supported, meaning that you might not obtain the result you expect.

## Adding Reverberation to the Sound (Reverb)

Here’s how to make reverb settings.

The available settings will depend on the selected type.

For details on the effects, refer to “Effect Parameter Guide” (PDF).

For details on how to obtain the PDF, refer to “Obtaining PDF Manuals” on the front cover.

1. In the Live Set Edit Menu screen, select “Reverb” and press the [ENTER] button (p. 28).
2. Select the parameter that you want to edit, and use the [DEC] [INC] buttons or the value dial to edit the value.

Parameter	Value	Explanation
Type	ROOM1, ROOM2	Simulates the reverberation of room interiors. It produces a well-defined and spacious reverberation.
	HALL1, HALL2	Simulates the reverberation exhibited by hall. It provides a deeper reverberation than the Room reverbs.
	PLATE	Simulates a plate reverb unit (a type of artificial reverb that utilized a metal plate).
	GM2 REVERB	This is a GM2 reverb.
Level	0–127	Reverb volume.

## Adding Spaciousness to the Sound (Delay)

Here’s how to make delay settings.

The available settings will depend on the selected type.

For details on the effects, refer to “Effect Parameter Guide” (PDF).

For details on how to obtain the PDF, refer to “Obtaining PDF Manuals” on the front cover.

1. In the Live Set Edit Menu screen, select “Delay” and press the [ENTER] button (p. 28).
2. Select the parameter that you want to edit, and use the [DEC] [INC] buttons or the value dial to edit the value.

Parameter	Value	Explanation
Type	DELAY	A stereo delay.
	T-CTRL DELAY	A delay that allows you to smoothly change the delay time.
	DELAY → TREMOLO	Tremolo is applied to the delay sound.
	2TAP DELAY	Delayed sound is heard from two locations that you specify.
	3TAP DELAY	Delayed sound is heard from three locations that you specify.
Level	0–127	Delay volume.

# Detailed Tone Settings (Designer)

After you've selected a tone or a Live Set, you can use the RD-800's Designer function to make detailed adjustments to the sound.

1. Hold down the [SHIFT] button and press the layer switch to which the sound you want to edit is assigned.

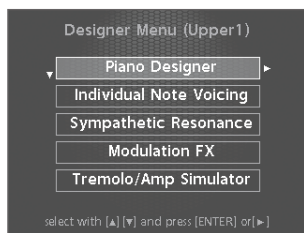

### MEMO

The items that are displayed will differ depending on the tone that's selected.

The selected layer's Designer Menu screen (for a TW-Organ sound, the Harmonic Bar screen) appears (p. 22).

In the designer menu you can choose the desired category of tone settings.

### MEMO

In the Tone screen, pressing the [ENTER] button will access the Designer Menu screen for UPPER 1.

2. Use the cursor [▲] [▼] buttons to select the item that you want to edit.

3. Press the [ENTER] button.

The edit screen for each item appears.

4. Select the parameter that you want to edit, and use the [DEC] [INC] buttons or the value dial to edit the value.

If you press the [EXIT/SHIFT] button, you will return to the Designer Menu screen.

5. If you want to save the changes you've made, press the [WRITE] button.

You can save your changes in the Live Set.

### NOTE

If you've edited the settings, an "EDITED" indication is shown in the Live Set screen or the Tone screen.

If you turn off the power, select another Live Set, or select another tone in the Tone screen while the "EDITED" indication is shown, the edits you made are discarded. If you want to keep your edits, press the [WRITE] button to save the Live Set (p. 23).

1. As described in "Detailed Tone Settings (Designer)," select "Piano Designer" and press the [ENTER] button.

The Piano Designer screen appears.

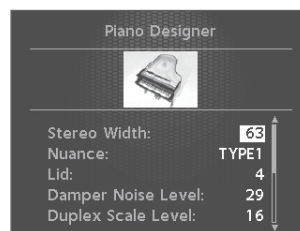

2. Select the parameter that you want to edit, and use the [DEC] [INC] buttons or the value dial to edit the value.

Parameter	Value	Explanation
Tone Color	0-127	Adjusts an effect that is suitable for each sound, such as the timbre or the acoustic image.
Nuance	TYPE1, TYPE2, TYPE3	Changes the Tone's subtle nuances by altering the phase of the left and right sounds. * This effect is difficult to hear when headphones are used.
Damper Noise	0-127	Adjusts the damper noise (the sound that occurs when the strings of an acoustic piano are released by pressing the damper pedal). Increasing this value increases the sound that is heard when the strings are released.
Duplex Scale	0-127	Adjusts the sound of the sympathetically vibrating aliquot strings on an acoustic piano. Higher values increase the volume of the sympathetic vibration.  <b>What is Duplex Scale?</b> "Duplex Scale" refers to a system that causes sympathetic vibrations in the sections of the string toward the front and toward the back. It can produce sound that is richer and brighter by adding the string's higher harmonics. Because no damper (sound-stopping mechanism) is applied to the front or back sections of the string, the resonating sounds linger even after the sound of the string stops when you release the played key.
String Resonance	0-127	When the keys are pressed on an acoustic piano, the strings for keys that are already pressed also vibrate sympathetically. The function that reproduces this is called "String Resonance." Increasing the value increases the amount of effect.
Key Off Resonance	0-127	Adjusts resonances such as the key-off sound of an acoustic piano (subtle sounds that are heard when you release a key). Higher values increase the volume of the resonances.
Hammer Noise	-2-0+2	Adjusts the sound of the hammers striking the strings of an acoustic piano. Higher values increase the sound of the hammers striking the strings.
Character	-5-0+5	Higher values produce a harder sound; lower values produce a more mellow sound.
Sound Lift	0-127	Lets you change the way that the sound responds when you play the keyboard softly. For example, this can be adjusted suitably for solo performance, or to prevent your sound from being buried in the rest of the band. Increasing this value will allow fairly loud sounds to be produced even when you play with a light touch, so that your performance will not be obscured by the playing of your band. Changing this value does not affect the way in which the sound responds to velocity.

## Piano Designer

If certain piano sounds are selected, Piano Designer appears in the Designer Menu.

\* For the tones that correspond to certain piano sounds, refer to "Sound List" (PDF).  
For details on how to obtain the PDF, refer to "Obtaining PDF Manuals" on the front cover.

In the Piano Designer screen, you can adjust various aspects of the sound of the piano to create a piano sound that's just right for you.

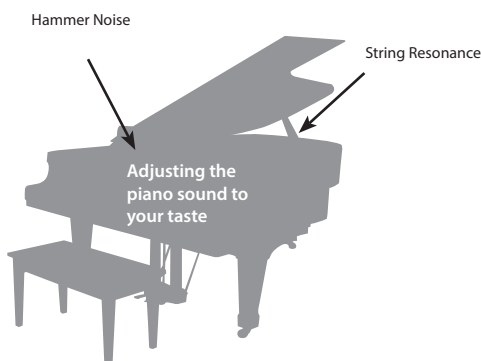

## Tone Designer

In the Tone Designer screen you can make detailed settings for the sound. The available parameters will depend on the tone that's selected.

1. As described in "Detailed Tone Settings (Designer)" (p. 32), select "Tone Designer" and press the [ENTER] button.

The Tone Designer screen appears.

The parameters will differ depending on the tone that's selected.

2. Select the parameter that you want to edit, and use the [DEC] [INC] buttons or the value dial to edit the value.

## Making Detailed Settings for the E. Piano Tones

If certain electric piano tones are selected, the following parameters will be shown.

- \* For the tones corresponding to certain electric piano tones, refer to "Sound List" (PDF).  
For details on how to obtain the PDF, refer to "Obtaining PDF Manuals" on the front cover.

Parameter	Value	Explanation
<b>Tone Color</b>	0-127	Adjusts an effect that's suitable for each sound, such as timbre or acoustic image.
<b>Mechanical Key On Noise</b>	0-127	Here you can adjust the loudness of the hammer strike on an electric piano's sound-producing mechanism, such as the tine or reed. Higher settings produce a louder hammer strike. * Depending on the tone that's selected, this might have no effect.
<b>Mechanical Key Off Noise</b>	0-127	Adjusts the key-off sound of the electric piano (the operating sound of the key and hammer when the key is released). Higher settings produce a louder key-off sound. * Depending on the tone that's selected, this might have no effect.
<b>Damper Noise</b>	0-127	Adjusts the damper noise (the noise heard when you press the damper pedal to release the tone bars). Increasing this value will make the damper noise louder. * Depending on the tone that's selected, this might have no effect.
<b>Key Off Resonance</b>	0-127	Adjusts resonances such as the key-off sound (the faint sound heard when you release a key). Higher values produce a louder key-off sound. At a setting of 0 there will be no key-off sound at all. * Depending on the tone that's selected, this might have no effect.
<b>Hum Noise</b>	0-127	Adjusts the amount of hum and other noise that leaks into the pickups. Electric pianos were susceptible to various types of noise, and this noise would sometimes be output along with the sounds of the performance. Depending on the effect settings, such noises can produce an authentic, lively atmosphere. Lowering this value makes the sound clearer; raising this value makes the sound dirtier. At a setting of 0 there will be no hum at all. * Depending on the tone that's selected, this might have no effect.
<b>Sound Lift</b>	0-127	Lets you change the way that the sound responds when you play the keyboard softly. For example, this can be adjusted suitably for solo performance, or to prevent your sound from being buried in the rest of the band. Increasing this value will allow fairly loud sounds to be produced even when you play with a light touch, so that your performance will not be obscured by the playing of your band. Changing this value does not affect the way in which the sound responds to velocity.

## Making Detailed Settings for the CLAV Tones

If certain clav tones are selected, the following parameters appear.

- \* For details on which clav tones this applies to, refer to "Sound List" (PDF).  
For details on how to obtain the PDF, refer to "Obtaining PDF Manuals" on the front cover.

Parameter	Value	Explanation
<b>Tone Color</b>	0-127	Adjusts an effect that's suitable for each sound, such as timbre or acoustic image.
<b>Pitch Bend Range</b>	0-24 (semi-tones)	Sets the amount of pitch change to occur when you move the Pitch Bend lever (maximum two octaves).
<b>Key Off Resonance</b>	0-127	Adjusts resonances such as the key-off sound (the faint sound heard when you release a key). Higher values produce a louder key-off sound. At a setting of 0 there will be no key-off sound at all.
<b>Hum Noise</b>	0-127	Adjusts the amount of hum and other noise that leaks into the pickups. Electric clavichords were susceptible to various types of noise, and this noise would sometimes be output along with the sounds of the performance. Depending on the effect settings, such noises can produce an authentic, lively atmosphere. Lowering this value makes the sound clearer; raising this value makes the sound dirtier. At a setting of 0 there will be no hum at all. * Depending on the tone that's selected, this might have no effect.

## Making Detailed Settings for the Other Tones

If you've selected a tone other than certain piano, electric piano, or clav tones, the following parameters appears.

Parameter	Value	Explanation
<b>Tone Color</b>	0-127	Adjusts an effect that's suitable for each sound, such as timbre or acoustic image.
<b>Mono/Poly</b>		Specifies whether the tone is to play polyphonically (POLY) or monophonically (MONO). The MONO setting is effective when playing a solo instrument tone, such as sax or flute. Additionally, when this is set to "MONO LEGATO," you can have monophonic performances be played legato. Legato is a playing style in which the spaces between notes are smoothed, creating a flowing feel with no borders between the notes. This creates a smooth transition between notes, which is effective when you wish to simulate the hammering-on and pulling-off techniques used by a guitarist.
	MONO	Only the last-played note will sound.
	POLY	Two or more notes can be played simultaneously.
	MONO LEGATO	Legato is applied to monophonic performances.
<b>Portamento Switch</b>	ON, OFF	Portamento is a function that causes the pitch to change smoothly from one note to the next note played. With the Mono/Poly parameter set to MONO, portamento is especially effective when simulating playing techniques such as violin glissandos.
<b>Portamento Time</b>	0-127	The Portamento Time setting determines the time for the change in pitch when the portamento effect is applied to the sound. Higher settings cause the pitch change to the next note to take more time.
<b>Pitch Bend Range</b>	0-24 (semi-tone)	Sets the amount of pitch change to occur when you move the Pitch Bend lever (maximum two octaves).

## Detailed Tone Settings (Designer)

Parameter	Value	Explanation
Attack Time Offset		The time it takes after the key is pressed for a sound to reach full volume. Higher values produce a milder attack; lower values produce a sharper attack. * With some Tones, the effect does not work as intended.
Decay Time Offset		This is the time over which the volume decays after the attack is finished. The time it takes for the volume to fall increases as the value is raised; lowering the value decreases the decay time. * With some Tones, the effect does not work as intended.
Release Time Offset		The time it takes after the key is released for a sound to become inaudible. Higher values produce longer decay; set lower values for a clear-cut sound. * With some Tones, the effect does not work as intended.
Cutoff Offset	-64→+63	Adjusts how much the filter is opened. Higher values brighten the sound; lower values make the sound seem darker. * With some Tones, the effect does not work as intended.
Resonance Offset		Emphasizes the overtones in the vicinity of the cutoff frequency, adding character to the sound. Excessively high settings can produce oscillation, causing the sound to distort. Higher values strengthen the distinctive characteristics of the sound; lower values reduce these characteristics. * With some Tones, the effect does not work as intended.
Vibrato Rate Offset		Adjusts the vibrato speed (the rate at which the pitch is modulated). The pitch is modulated more rapidly for higher settings, and more slowly with lower settings.
Vibrato Depth Offset		Adjusts the depth of the vibrato effect (the depth at which the pitch is modulated). The pitch is modulated more greatly for higher settings, and less with lower settings.
Vibrato Delay Offset		For each part, this adjusts the time until vibrato (pitch modulation) begins. Higher settings produce a longer delay time before vibrato begins, while lower settings produce a shorter time.

## Editing Individual Keys (Individual Note Voicing)

### NOTE

- These settings are available only when editing certain piano tones.
- For details on the tones to which this applies, refer to “Sound List” (PDF).  
For details on how to obtain the PDF, refer to “Obtaining PDF Manuals” on the front cover.

1. In the procedure “Detailed Tone Settings (Designer)” (p. 32), choose “Individual Note Voicing” and press the [ENTER] button.
2. Use the cursor buttons to select a parameter.
3. Press a key to specify the key that you want to edit.
4. Use the [DEC] [INC] buttons or the value dial to edit the values.

### Tuning

You can make fine adjustments to the tuning of each key.

Parameter	Value	Explanation
Type	OFF, PRST (PRESET), USER	Selects the type of tuning. PRST (PRESET) is the tuning curve that’s factory-set for the RD-800. If you choose USER, you’ll be able to specify the tuning of each key.
Value	-50.0→+50.0	Allows for fine adjustments to the tuning of each key in steps of 0.1 cents, over a range of -50.0 to +50.0 cents.

### Level

This is a fine adjustment to the volume of each key.

Parameter	Value	Explanation
Type	OFF, USER	If you choose USER, you’ll be able to edit the volume of each key.
Value	-50-0	Lower values cause the key to be softer than the other keys.

### Character

Relative to the value of the “Character” parameter in Piano Designer, this lets you adjust the offset value for each key.

Parameter	Value	Explanation
Type	OFF, USER	If you choose USER, you’ll be able to edit the Character offset value of each key.
Value	-5-0→+5	Higher values produce a harder sound; lower values make the tone more mellow.

### MEMO

If you change the value of a key from “OFF” or “PRST,” the Type will automatically change to “USER.”

## Adjusting Resonance when the Damper Pedal Is Depressed (Sympathetic Resonance)

### NOTE

This setting is available only for certain piano tones.

For details on the tones to which this applies, refer to “Sound List” (PDF).

For details on how to obtain the PDF, refer to “Obtaining PDF Manuals” on the front cover.

You can adjust this resonance when the damper pedal is depressed (Sympathetic Resonance).

On an acoustic piano, holding down the damper pedal will allow the remaining strings to resonate in sympathy with the sounds that you played from the keyboard, adding a rich resonance. This feature reproduces that resonance sound.

Parameter	Value	Explanation
Switch	OFF, ON	When set to ON, the effect is applied.
Depth	0–127	Depth of the effect
Damper	0–127	Depth to which the damper pedal is pressed (controls the resonant sound)
Pre LPF	16–15000 Hz, BYPASS	Frequency of the filter that cuts the high-frequency content of the input sound (BYPASS: no cut)
Pre HPF	BYPASS, 16–15000 Hz	Frequency of the filter that cuts the low-frequency content of the input sound (BYPASS: no cut)
Peaking Freq	16–15000 Hz	Frequency of the filter that boosts/cuts a specific frequency region of the input sound
Peaking Gain	–15+15 dB	Amount of boost/cut produced by the filter at the specified frequency region of the input sound
Peaking Q	0.5, 1.0, 2.0, 4.0, 8.0	Width of the frequency region boosted/cut by the Peaking Gain parameter (larger values make the region narrower)
HF Damp Freq	16–15000 Hz, BYPASS	Frequency at which the high-frequency content of the resonant sound will be cut (BYPASS: no cut)
LF Damp Freq	BYPASS, 16–15000 Hz	Frequency at which the low-frequency content of the resonant sound will be cut (BYPASS: no cut)
Level	0–127	Output Level
Damper Offset	0–127	Volume of additional slight resonance when the damper pedal is not pressed

## Editing the Modulation FX (Modulation FX)

Here you can edit the modulation FX parameters.

1. While holding down the [SHIFT] button, operate the MODULATION FX [DEPTH] (or [RATE]) knob.  
The Modulation FX screen appears.
2. Select the parameter that you want to edit, and use the [DEC] [INC] buttons or the value dial to edit the value.

Parameter	Value	Explanation
Type	Refer to the effect list (p.58).	Specifies the type of Modulation FX. The editable parameters will depend on the effect type that's selected.

Parameter	Value	Explanation
Routing	MOD FX (Modulation FX) → TR/AMP (Tremolo/Amp Simulator)  TR/AMP (Tremolo/Amp Simulator) → MOD FX (Modulation FX)	Lets you select the routing of the Modulation FX and the Tremolo/Amp Simulator. By switching the Routing type, you can change the effect that's applied to the sound. For example, suppose that you chose Chorus as the MOD FX and chose E.PIANO for TR/AMP; with the MOD FX → TR/AMP setting, the chorus sound will be output in monaural, but with the TR/AMP → MOD FX setting it will be output in stereo.
Switch	OFF, ON	Turns the Modulation FX on/off.

### MEMO

For details, refer to “Effect List” (p. 58) and “Effect Parameter Guide” (PDF).

For details on how to obtain the PDF, refer to “Obtaining PDF Manuals” on the front cover.

## Editing Tremolo/Amp Simulator (Tremolo/Amp Simulator)

Here's how to edit the Tremolo/Amp Simulator parameters.

1. While holding down the [SHIFT] button, operate the TREMOLO/AMP SIM [DEPTH] (or [RATE]) knob.  
The Tremolo/Amp Simulator screen appears.
2. Select the parameter that you want to edit, and use the [DEC] [INC] buttons or the value dial to edit the value.

Parameter	Value	Explanation
Type	Refer to “Tremolo/Amp Simulator types” (p. 35)	Selects the type of Tremolo/Amp Simulator. The editable parameters will depend on the effect type that's selected.
Routing	MOD FX (Modulation FX) → TR/AMP (Tremolo/Amp Simulator)  TR/AMP (Tremolo/Amp Simulator) → MOD FX (Modulation FX)	Lets you select the routing of the Modulation FX and the Tremolo/Amp Simulator. By switching the Routing type, you can change the effect that's applied to the sound. For example, suppose that you chose Chorus as the MOD FX and chose E.PIANO for TR/AMP; with the MOD FX → TR/AMP setting, the chorus sound will be output in monaural, but with the TR/AMP → MOD FX setting it will be output in stereo.

## Tremolo/Amp simulator types

	Type	Explanation
1	NORMAL	This is an amp with a flat frequency response. It allows you to add a tremolo effect and distortion.
2	A.PIANO	In addition to NORMAL, this reproduces the open/closed state of a grand piano's lid.

Type	Explanation
3 E.PIANO	<p>Tremolo types of differing character are available, allowing you to reproduce the character of classic electric pianos when combined with an electric piano sound.</p> <p><b>Characteristics of the tremolo types</b> .....</p> <p><b>OLDCASE MONO</b> Used in conjunction with TINE EP, this simulates an early model of a classic electric piano of the 60s.</p> <p><b>OLDCASE STEREO</b> Used in conjunction with TINE EP, this simulates a classic electric piano sound of the early 70s.</p> <p><b>NEWCASE</b> Used in conjunction with TINE EP, this simulates a classic electric piano sound of the late 70s and early 80s.</p> <p><b>DYNO</b> This model allows you to vary the shape of the tremolo waveform. Used in conjunction with TINE EP, this simulates an electric piano sound used in many recordings of the early 80s.</p> <p><b>WURLY</b> Used in conjunction with REED E.PIANO, this simulates a classic electric piano sound of the 60s.</p>
4 GUITAR AMP	<p>Simulates playing through a guitar amp.</p> <p><b>MEMO</b> Since the [DRIVE] knob faithfully simulates the volume knob of a guitar amp, turning the knob toward the left will also decrease the volume.</p>
5 ROTARY	<p>This simulates a rotary effect suitable for organ sounds.</p>

**MEMO**

For details, refer to "Effect Parameter Guide" (PDF).  
 For details on how to obtain the PDF, refer to "Obtaining PDF Manuals" on the front cover.

## Simulating the Creation of Organ Tones

These settings are available only if a TW-Organ (tonewheel organ) tone is selected.

On a tonewheel organ, you can create original sounds by sliding nine harmonic bars (drawbars) forward or backward to change their relative balance. Each bar is assigned a different footage, and this footage determines the pitch of the sound. 8' is the footage that forms the basic pitch of the sound; this is the center around which you create the tone.

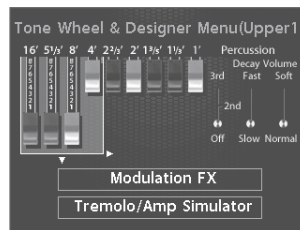

For details, refer to "Creating the Organ Tones" (p. 22).

# Using the RD-800 As a Master Keyboard

By connecting an external MIDI device to the MIDI OUT connectors on the RD-800's rear panel, you can then control the external MIDI device from the RD-800.

Normally, the RD-800 will transmit note messages from the MIDI OUT connector, but if you press the [MIDI CONTROL] button so the button is lit, you'll be able to control various settings on your external MIDI device in addition to transmitting note messages.

You can control internal and external sound generators independently.

If you press the [MIDI CONTROL] button so the button is lit, the RD-800 will be in a state where it can control an external MIDI sound module (EXTERNAL layer). You press the [MIDI CONTROL] button to switch between control of the Layer and control of the EXTERNAL layer.

You can also make detailed settings for MIDI messages transmitted to external sound modules.

\* If Rec Mode (p. 47) is "ON," you can't change the EXTERNAL layer settings. Nor will the MIDI Control screen appear when you press the [MIDI CONTROL] button.

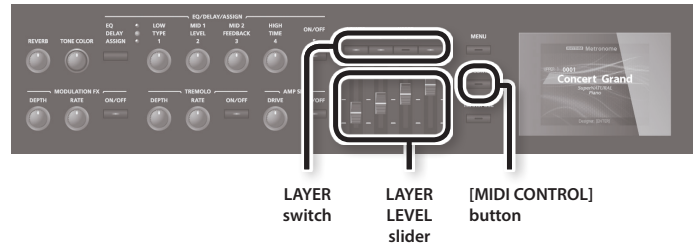

## What's MIDI?

MIDI (Musical Instrument Digital Interface) is a standard specification that allows musical data to be exchanged between electronic musical instruments and computers.

If devices equipped with MIDI ports are connected via a MIDI cable, you'll be able to use them in the following ways.

- Use one MIDI keyboard to play multiple instruments
- Play multiple MIDI instruments as an ensemble
- Automatically switch settings as the song progresses

## About MIDI Connectors

The RD-800 has the following three types of MIDI connectors. Their functions differ as described below.

### MIDI IN connector

Performance messages from an external MIDI device are received here. These incoming messages may instruct the RD-800 to play sounds or switch tones.

### MIDI OUT connector

MIDI messages are transmitted from these connectors to external MIDI devices. The RD-800's MIDI OUT connectors are used for sending the performance data of the controller section.

### MIDI THRU connector

MIDI messages received at MIDI IN connectors are re-transmitted without change from this connector to an external MIDI device. Use this in situations such as when you use multiple MIDI devices simultaneously.

#### MEMO

The RD-800 lets you switch the function of the MIDI THRU/OUT 2 connector (p. 41).

## Adjusting the Volume of Each Layer

When the [MIDI CONTROL] button is lit, you can use the Layer switch and Layer LEVEL sliders to control the EXTERNAL Layer in the same way as with the Layer (p. 12).

## LAYER switch

This specifies whether MIDI data including the notes you play on the keyboard in the EXTERNAL layer will be transmitted from the MIDI OUT connector if the [MIDI CONTROL] button is lit.

When the Layer switch indicator for a Layer is lit (on), MIDI messages are transmitted from the MIDI OUT connector when the keys for that Layer are played.

When the Layer switch indicator for a Layer is not lighted (off), MIDI messages are not transmitted from the MIDI OUT connector even when the keys for that part are played.

The Layer switch will turn on or off each time you press it.

## LAYER LEVEL slider

If the [MIDI CONTROL] button is lit, these sliders adjust the volume of the EXTERNAL layers.

## Selecting the MIDI Connector to Use for Output

The RD-800 provides a MIDI OUT connector, a MIDI connector whose function can be switched between OUT and THRU, and a USB COMPUTER port.

For each layer you can select the MIDI OUT connector or USB COMPUTER port from which its data is to be transmitted.

### 1. Press the [MIDI CONTROL] button so the button is lit.

The MIDI Control screen appears.

If the screen does not indicate "OUT," press the cursor [←] button a number of times until "OUT" is indicated in the screen.

### 2. Use the Cursor buttons to move the cursor, and use the [DEC] [INC] buttons or the value dial to specify the connector from which each layer will transmit its MIDI data

Layer	Parameter	Settings	Explanation
UPPER1	OUT (MIDI OUT Port)	ALL, OUT1 (MIDI OUT1), OUT2 (MIDI OUT2), USB	The RD-800's performance data is transmitted from the selected connector.
UPPER2			
UPPER3			
LOWER			

#### MEMO

If the System parameter MIDI OUT2 Port Setting (p. 41) is set to "THRU," the performance data from the RD-800 will not be transmitted from the MIDI OUT 2 connector; instead, the performance data received at the MIDI IN connector will be retransmitted without change (MIDI THRU).

## Setting the MIDI Transmit Channel

When you have finished connecting the external MIDI device, match the keyboard's Transmit channel and the Receive channel for each of the external MIDI sound generator's Parts. Sound is produced when the MIDI channels for the sending device (the RD-800) and the receiving device (the external MIDI sound generator) are set to the same MIDI channel.

### 1. Press the [MIDI CONTROL] button so the button is lit.

The MIDI Control screen appears.

If "Ch" doesn't appear on screen, press the Cursor [◀] button a number of times to display the following screen.

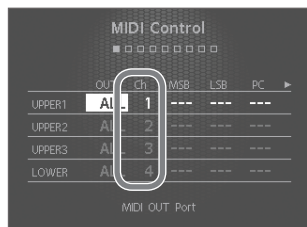

#### MEMO

For details on how to set the receive channel for each part of your external MIDI device, refer to its owner's manual.

### 2. Use the Cursor buttons to move the cursor, and use the [DEC] [INC] buttons or the value dial to set the Transmit channel (Ch) for each layer.

Layer	Parameter	Value	Explanation
UPPER1	Ch (MIDI Tx Channel)	1-16	RD-800 performance data is sent over a selected channel.
UPPER2			
UPPER3			
LOWER			

#### MEMO

- Layers that have their Layer switch turned off are dimmed in the screen (p. 12). Also, MIDI messages are not transmitted when you play the keyboard.

## Selecting Sounds on an External MIDI Device

To switch the tones of an external MIDI device, the program number and the MSB/LSB of the Bank Select message are entered as numerical values on the RD-800.

### 1. Press the [MIDI CONTROL] button so the button is lit

The MIDI Control screen appears.

If "MSB" doesn't appear on screen, press the Cursor [◀] [▶] buttons a number of times to display the following screen.

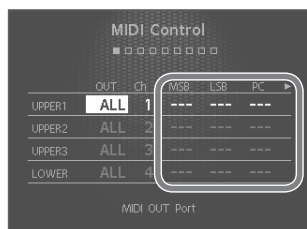

### 2. Use the Cursor buttons to move the cursor, and use the [DEC] [INC] buttons or the value dial to set the MSB, LSB, and PC for each layer

When this setting is "--" bank select and program change messages will not be transmitted.

Parameter	Value
MSB (Bank Select MSB: CC0)	--, 0-127
LSB (Bank Select LSB: CC32)	--, 0-127
PC (Program Change)	--, 1-128

#### NOTE

- If the external MIDI sound generator receives a Program number or a Bank number for which no Tone has been assigned, an alternate Tone may be selected, or in some cases, there may be no sound played.
- If you do not want to transmit the Program number or Bank Select, use the procedure described above to set the PC/MSB/LSB to "--".
- If this is set to "--" the sound selection data will not be transmitted when you switch Live Sets.

## Detailed Settings for Transmitted Parts

### 1. Press the [MIDI CONTROL] button so the button is lit.

The RD-800 is set to control the external MIDI devices.

### 2. Press the Cursor buttons to move the cursor to the parameter to be set.

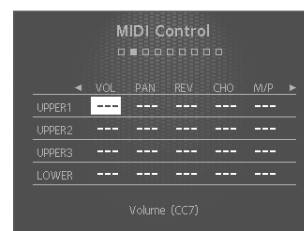

### 3. Use the [DEC] [INC] buttons or value dial to set the value.

If you press the [DEC] button and [INC] button simultaneously, the value will be reset to "--" or to the default setting. The value for the setting won't be transmitted when set to "--".

Parameter	Value	Explanation
OUT MIDI OUT Port	ALL, OUT1, OUT2, USB	The RD-800's performance data is transmitted from the selected connector.
Ch MIDI Tx Channel	1-16	RD-800 performance data is sent over a selected channel.
MSB Bank Select MSB (CC0)	--, 0-127	Here you can specify the sound that you want to select on your external MIDI device by entering its program number and bank select MSB/LSB values.
LSB Bank Select LSB (CC32)	--, 0-127	
PC Program Change	--, 1-128	
VOL Volume (CC7)	--, 0-127	Adjusts the volume balance between layers.
PAN Pan (CC10)	--, L64-0-R63	The Pan setting positions the sound image of each layer when the output is in stereo. With an increase in the value for L, more of the sound will be heard as coming from the left side. Similarly, more of the sound will originate at the right if the value of R is increased. When set to 0, the sound is heard as coming from the center.
REV Reverb Send Level (CC91)	--, 0-127	Sets the depth of the reverb effects.
CHO Chorus Send Level (CC93)	--, 0-127	Sets the depth of the chorus effects.
M/P Mono (CC126) Poly (CC127)	--, M (Mono), P (Poly)	Specifies whether the tone will play polyphonically (Poly) or monophonically (Mono). The Mono setting is effective when playing a solo instrument tone such as sax or flute.
TRA Layer Transpose	-48-+48	You can perform with each layer transposed to a different pitch. When multiple layers are set to on, you can create a richer sound by setting the two Tones to different octaves. Also, if the Keyboard Mode is set to Split (p. 13), and you are playing a bass Tone in the lower Part, you can use the Transpose function to play the bass at a lower pitch.

Parameter	Value	Explanation
<b>KR.LWR</b> Keyboard Range Lower	A0–C8	Set the keyboard range in which each Layer will sound. This can be used to make notes in different areas of the keyboard play different Tones. Specify the lower limit (KR.LWR) and upper limit (KR.UPR) of the key range being set. You can also set this by pressing a specific key and then pressing the [ENTER] button.
<b>KR.UPR</b> Keyboard Range Upper		* This is effective only when the [SPLIT] button is on (p. 13) in the key range settings. * "Full" is displayed when the [SPLIT] button is set to OFF.
<b>VR.LWR</b> Velocity Range Lower	1–127	Specify the lower limit (VR.LWR) and upper limit (VR.UPR) of the range in which the tone is played according to how strongly the keys are played (velocity). Make this setting when you want the tone to change depending on the key velocity.
<b>VR.UPR</b> Velocity Range Upper		
<b>ATK</b> Attack Time Offset (CC73)	---, -64→+63	The time it takes after the key is pressed for a sound to reach full volume. Higher values produce a milder attack; lower values produce a sharper attack.
<b>DCY</b> Decay Time Offset (CC75)		This is the time over which the volume decays after the attack is finished. The time it takes for the volume to fall increases as the value is raised; lowering the value decreases the decay time.
<b>REL</b> Release Time Offset (CC72)		The time it takes after the key is released for a sound to become inaudible. Higher values produce longer decay; set lower values for a clear-cut sound.
<b>COF</b> Cutoff Offset (CC74)		Adjusts how much the filter is opened. Higher values brighten the sound; lower values make the sound seem darker.
<b>RES</b> Resonance Offset (CC71)		Emphasizes the overtones in the vicinity of the cutoff frequency, adding character to the sound. Excessively high settings can produce oscillation, causing the sound to distort. Higher values strengthen the distinctive characteristics of the sound; lower values reduce these characteristics.
<b>POR</b> Portamento Switch (CC65)	---, OFF, ON	Portamento is a function that causes the pitch to change smoothly from one note to the next note played. The Portamento Time setting determines the time for the change in pitch when the portamento effect is applied to the sound. Higher settings will cause the pitch change to the next note to take more time.
<b>P.T</b> Portamento Time (CC5)	---, 0–127	
<b>C.TUNE</b> Coarse Tune	---, -48→+48	Adjusts the pitch in semitone steps (+/-4 octaves).
<b>F.TUNE</b> Fine Tune	---, -50→+50	Adjusts the pitch in one-cent steps (+/-50 cents). 1 cent = 1/100th of a semitone
<b>B.R</b> Pitch Bend Range	---, 0–48	Sets the amount of pitch change to occur when you move the Pitch Bend lever (4 octaves). (RPN: 00H/00H)
<b>M.D</b> Modulation Depth	---, 0–127	Sets the depth of the effect when the Modulation lever is tilted. (RPN: 00H/05H)

Parameter	Value	Explanation
<b>DAMP</b> Damper Control Switch	OFF, ON	Damper pedal
<b>FC1</b> FC1 Control Switch		Pedal connected to the FC1 jack
<b>FC2</b> FC2 Control Switch		Pedal connected to the FC2 jack
<b>EXT</b> EXT Pedal Control Switch		Pedal connected to the EXT jack
<b>PB</b> Pitch Bend Control Switch		Pitch Bend Lever
<b>MD</b> Modulation Control Switch		Modulation Lever
<b>S1</b> S1 Control Switch	OFF, ON	[S1] button
<b>S2</b> S2 Control Switch		[S2] button
<b>A1</b> Assign 1 Control Switch		ASSIGN [1] knob
<b>A2</b> Assign 2 Control Switch		ASSIGN [2] knob
<b>A3</b> Assign 3 Control Switch		ASSIGN [3] knob
<b>A4</b> Assign 4 Control Switch	ASSIGN [4] knob	
<b>A5</b> Assign 5 Control Switch	ASSIGN [5] button	
<b>CC1</b> User Control Change 1 Number	---, 0–127	You can assign and transmit two different control change messages.
<b>Value</b> User Control Change 1 Value		
<b>CC2</b> User Control Change 2 Number		
<b>Value</b> User Control Change 2 Value		

Specifies whether a pedal or other controller connected to each PEDAL jack will (ON) or will not (OFF) control an external MIDI device.

# Detailed Settings for Each Function

## Setting Parameters (System)

Functions that affect the overall operating environment of the RD-800 are called “system functions.”

For details on how to select parameters, refer to “Accessing the Menu Screens” (p. 26).

Parameter	Value	Explanation
Master Tune	415.3–440.0–466.2 [Hz]	<b>Tuning to Other Instruments’ Pitches (Master Tune)</b> For a cleaner ensemble sound while performing with one or more other instruments, ensure that each instrument’s basic pitch is in tune with that of the other instruments. In general, the tuning of an instrument is indicated by the pitch in Hertz (Hz) of the middle “A” note.
EQ Mode	LIVE SET REMAIN	<b>Retaining the Equalizer Settings Even When the Live Set Is Switched (EQ Mode)</b> You can store different equalizer settings (p. 15) for each individual Live Set (p. 10). This setting determines whether or not the Live Set equalizer settings values are to be changed when Live Sets are switched.
		When you switch Live Sets, the equalizer settings will also switch.
		When you switch Live Sets, the equalizer settings will not change.
Select Button Mode	LIVE SET REMAIN	<b>Retaining the Function Select Button Settings Even When the Live Set is Switched (Select Button Mode)</b> Function select button settings (p. 16) can be stored individually for each Live Set (p. 10). You can specify whether the function select button settings will or will not change to the functions stored in each Live Set when you switch a Live Set.
		When you switch Live Sets, the function select button settings will also change.
		When you switch Live Sets, the function select button settings will not change.
Pedal Mode	LIVE SET REMAIN	<b>Retaining the Pedal Settings Even When the Live Set Is Switched (Pedal Mode)</b> Pedal settings (p. 29) can be stored for each Live Set (p. 10). This setting determines whether or not the pedal settings are switched to the values stored in the Live Set you are switching to.
		When you switch Live Sets, the pedal settings will also change.
		When you switch Live Sets, the pedal settings will not change.
S1/S2 Mode	LIVE SET REMAIN	<b>Retaining the [S1] [S2] Button Settings Even When the Live Set Is Switched (S1/S2 Mode)</b> The settings of the [S1] [S2] buttons can be stored for each Live Set (p. 10). This setting determines whether or not the settings of the [S1] [S2] buttons are switched to the values stored in the Live Set you are switching to.
		When you switch Live Sets, the settings of the [S1] button and [S2] button will also change.
		When you switch Live Sets, the settings of the [S1] button and [S2] button will not change.
Assign 1-5 Mode	LIVE SET REMAIN	<b>Retaining the Assign 1–5 Controller Settings Even When the Live Set Is Switched (Assign 1-5 Mode)</b> The settings of the Assign 1–5 controllers (p. 28) can be stored individually for each Live Set (p. 10). You can specify whether the Assign 1–5 controller settings stored in the Live Set will or will not change when you switch Live Sets.
		When you switch Live Sets, the Assign 1–5 controller settings will also change.
		When you switch Live Sets, the Assign 1–5 controller settings will not change.
Delay Mode	LIVE SET REMAIN	<b>Retaining the Delay Settings Even When the Live Set Is Switched (Delay Mode)</b> Delay settings (p. 31) can be stored individually for each Live Set (p. 10). You can specify whether the delay settings will or will not change to the values stored in each Live Set when you select a Live Set.
		When you switch Live Sets, the delay settings will also change.
		When you switch Live Sets, the delay settings will not change.

Parameter	Value	Explanation
Reverb Mode		<h3>Retaining the Reverb Settings Even When the Live Set Is Switched (Reverb Mode)</h3> <p>Reverb settings (p. 31) can be stored individually for each Live Set (p. 10). You can specify whether the reverb settings will or will not change to the values stored in each Live Set when you select a Live Set.</p>
	LIVE SET	When you switch Live Sets, the reverb settings will also change.
	REMAIN	When you switch Live Sets, the reverb settings will not change.
Rhythm Mode		<h3>Retaining the Rhythm Settings Even When the Live Set is Switched (Rhythm Mode)</h3> <p>Rhythm pattern, tempo, and volume (p. 24) can be stored individually for each Live Set (p. 10). You can specify whether the Rhythm settings will or will not change to the value stored in each Live Set when you switch a Live Set.</p>
	LIVE SET	When you switch Live Sets, the rhythm settings will also change.
	REMAIN	When you switch Live Sets, the rhythm settings will not change.
Key Touch Mode		<h3>Retaining the Keyboard Touch Settings Even When the Tone or Live Set is Switched (Key Touch Mode)</h3> <p>Key Touch settings (p. 29) can be stored individually for each Live Set (p. 10). You can specify whether the Key Touch settings will or will not change to the values stored in each Live Set when you switch a Live Set. You can also specify whether the tone's Key Touch settings (valid only for the UPPER1 layer) will or will not be applied when you switch tones.</p>
	TONE/LIVE SET	When you switch tones or Live Sets, the Key Touch settings will also change. (*1)
	REMAIN	When you switch tones or Live Sets, the Key Touch settings will not change.
Tone/Live Set Remain	OFF, ON	<h3>Retaining the Current Tone Even When Tones Are Switched (Tone/Live Set Remain)</h3> <p>This setting specifies whether the tone currently being sounded will continue (ON) or not (OFF) when another tone is selected.</p> <p><b>NOTE</b></p> <ul style="list-style-type: none"> <li>Effects (Reverb, Delay, EQ, Sympathetic Resonance) settings change as soon as you switch to a new Tone, without being influenced by the Tone/Live Set Remain setting. Because of this, certain effects settings can cause notes that were until then sounding to no longer be heard, even though Tone/Live Set Remain has been set to ON.</li> <li>Even if Tone/Live Set Remain is set to ON, the sound of the current tone is not carried over when changing from a Virtual Tone Wheel tone to a non-Virtual Tone Wheel tone.</li> </ul>
Live Set Control Channel		<h3>Using Program Change Messages to Switch LIVE SETS (Live Set Control Channel)</h3> <p>You can switch the RD-800's Live Sets with MIDI messages from an external MIDI device.</p> <p><b>MEMO</b></p> <p>For details, refer to "MIDI Implementation" (PDF). For details on how to obtain the PDF, refer to "Obtaining PDF Manuals" on the front cover.</p>
	OFF	When not switching Live Sets from an external MIDI device, set this to OFF.
	1-16	Sets the MIDI Receive channel for receiving the MIDI messages (Bank Select and Program Change) from the external MIDI device to be used for switching Live Sets.
USB Driver		<h3>Selecting the USB Driver (USB Driver)</h3> <p>→ Refer to "Switching USB Drivers" (p. 53)</p>
USB MIDI Thru Switch		<h3>Selecting the USB MIDI Thru Switch (USB MIDI Thru Switch)</h3> <p>→ Refer to "Using the RD-800 As a USB MIDI Interface" (p. 53)</p>
MIDI OUT2 Port Mode		<h3>Selecting the Function of the MIDI THRU/OUT 2 Connector (MIDI OUT2 Port Mode)</h3> <p>This setting specifies the function of the RD-800's MIDI THRU/OUT 2 connector.</p>
	OUT	If you choose "OUT," the connector will function as MIDI OUT, and will transmit data from the keyboard and controllers to an external MIDI device.
	THRU	If you choose "THRU," the connector will function as MIDI THRU, retransmitting without change the MIDI messages that are received at the MIDI IN connector. Performance data from the RD-800 itself will no longer be sent from this connector.

\*1 The setting will not be changed by operations in the Layer Edit screen (p. 28) or when a MIDI message is received to switch tones.

## Detailed Settings for Each Function

Parameter	Value	Explanation
Damper Polarity	STANDARD, REVERSE	<h3>Switching the Pedal's Polarity (Damper/FC1/FC2/EXT Pedal Polarity)</h3> <p>Switch the polarity of pedals connected to the RD-800.</p> <p>This can be set individually for each of the Pedal jacks on the rear panel (FC1, FC2, DAMPER, EXT Pedal).</p> <p>On some pedals, the electrical signal output by the pedal when it is pressed or released is the opposite of other pedals.</p> <p>If your pedal has an effect opposite of what you expect, set this parameter to reverse.</p> <p>If you are using a Roland pedal (that has no polarity switch), set this parameter to STANDARD.</p>
FC1 Polarity		
FC2 Polarity		
EXT Pedal Polarity		
Temperament		<h3>Setting the Tuning Method (Temperament/Key)</h3> <p>This sets the tuning and keynote (tonic).</p> <p>Most modern songs are composed and played with the assumption that equal temperament will be used, but when classical music was composed, there were a wide variety of other tuning systems in existence. Playing a composition with its original tuning lets you enjoy the sonorities of the chords that the composer originally intended.</p> <p>When playing with tuning other than equal temperament, you need to specify the keynote for tuning the song to be performed (that is, the note that corresponds to C for a major key or to A for a minor key).</p> <p>If you choose an equal temperament, there's no need to select a keynote.</p>
	EQUAL	<p>Equal Temperament</p> <p>This tuning divides an octave into 12 equal parts. Every interval produces about the same amount of slight dissonance.</p>
	JUST MAJ	<p>Just (Major): This scale eliminates dissonance in fifths and thirds. It is unsuited to playing melodies and cannot be transposed, but is capable of beautiful sonorities.</p>
	JUST MIN	<p>Just (Minor): The scales of the major and minor just intonations are different. You can get the same effect with the minor scale as with the major scale.</p>
	PYTHAGOREAN	<p>Pythagorean: This scale, devised by the philosopher Pythagoras, eliminates dissonance in fourths and fifths. Dissonance is produced in thirds, but melodies are euphonious.</p>
	KIRNBERGER	<p>Kirnberger: This scale is a modification of the meantone and just intonations that permits greater freedom in transposition to other keys. Performances are possible in all keys (III).</p>
	MEANTONE	<p>Meantone: This scale makes some compromises in just intonation, enabling transposition to other keys.</p>
	WERCKMEISTER	<p>Werckmeister: This is a combination of the meantone and Pythagorean scales. Performances are possible in all keys (first technique, III).</p>
ARABIC	<p>Arabic Scale: This scale is suitable for Arabic music.</p>	
Temperament Key	C, C#, D, Eb, E, F, F#, G, G#, A, Bb, B	Sets the keynote.
Part Switch	OFF, ON (Part 1–Part 16)	<h3>Selecting the Parts That Will Produce Sound (Part Switch 1–16)</h3> <p>Here you can specify whether or not performance data is to be received from an external MIDI device.</p> <p>Part Switch settings can be made individually for each part.</p> <p>To make these settings, select "Part Switch" and press the [ENTER] button to access the edit screen for each part.</p> <p><b>NOTE</b></p> <p>Tone Color and effects are not available for the parts received on channels 5–16. They may sound differently than the sounds played on channels 1–4.</p>
Clock Out	OFF, ON	<h3>Transmitting Synchronization Messages (Clock Out)</h3> <p>This setting determines whether or not the MIDI messages necessary to synchronize the RD-800 with external devices are to be transmitted from the MIDI OUT connector.</p>

Parameter	Value	Explanation
Hi-Res Velocity Out	OFF, ON	<b>Transmitting High-Resolution Velocity Data (Hi-Res Velocity Out)</b> This specifies whether high-resolution velocity data is to be transmitted from the MIDI OUT connector.
Rhythm MIDI Output Port	ALL, OUT1, OUT2, USB	<b>Selecting the MIDI Output Port for Rhythm (Rhythm MIDI Output Port)</b> This specifies the port from which the rhythm part is to be transmitted.
Rhythm MIDI Out Channel	OFF, 1–16	<b>Selecting the MIDI Output Channel for Rhythm (Rhythm MIDI Channel)</b> This specifies the MIDI channel on which the rhythm part is to be output.
Audio Volume	0–127	<b>Adjusting the Playback Volume of Audio Files</b> This specifies the volume at which audio files play back.
LCD Brightness	1–10	<b>Adjusting the Brightness of the Display (LCD Brightness)</b> You can adjust the brightness of the RD-800's display.
Knob LED Switch		<b>Settings for Knob LED Illumination (Knob LED Switch)</b> Here you can specify whether the knob LEDs are to be illuminated or unlit.
	OFF	The knobs will always be unlit.
	ON	The knob LED will light if turning the knob would produce a change. If the knob operation is unavailable, the knob LED will remain unlit.
Display Theme	THEME1, THEME2, THEME3	<b>Changing the Background Image (Display Theme)</b> This lets you change the background images for the Tone screen and the Live Set screen.
Auto Off	OFF, 30 [min], 240 [min] (default)	<b>Making the Power Automatically Turn Off After a Time (Auto Off)</b> With the factory settings, the RD-800 will automatically be switched off 4 hours after you stop playing or operating the unit. If you don't need the unit to turn off automatically, set "Auto Off" to the "OFF" setting. * When turning the unit back on after it has been shut down due to the Auto Off function, always make sure to allow at least ten seconds to pass after the unit has been shut off before you turn the unit back on. If you turn it back on too rapidly, the Auto Off function will not have had enough time to reset itself, and you may not be able to turn on the unit in the normal way.

## Saving System Settings

Changes you make to the system settings are temporary, and will be lost when you turn off the power.

If you want to keep your changes, you must save the system settings.

### 1. In the System, System Compressor, or V-LINK/MVC screen, press the [WRITE] button.

The system settings are saved in the RD-800's system memory.

### Parameters saved in SYSTEM (System parameter)

- System
- System Compressor
- V-LINK/MVC

However, the following settings are not saved.

MIDI VISUAL CONTROL On or Off

### Making the System Compressor Settings (System Compressor)

This is a stereo compressor (limiter) that is applied to the final output.

With separate settings for the high-frequency range, midrange, and low-frequency range, this reduces inconsistencies in volume levels by compressing the sound when the volume exceeds a preset volume level.

Parameter	Value	Explanation
<b>Compressor Switch</b>	OFF, ON	Turns the compressor on/off.
<b>Type (Compressor Type)</b>		When you change this parameter, the Compressor parameters will be automatically adjusted to the optimal values. You can make the settings easily by first setting the Compressor Type and then changing only the necessary parameters.
	HARD COMP	Applies strong compression.
	SOFT COMP	Applies mild compression.
	LOW BOOST	Boosts the low end.
	MID BOOST	Boosts the midrange.
	HI BOOST	Boosts the high end.
	USER	The saved settings are written.
<b>Split Freq Low</b>	40, 50, 63, 80, 100, 125, 160, 200, 250, 315, 400, 500, 630, 800 [Hz]	Sets the frequency separating the low-frequency range (LOW) and midrange (MID).
<b>Split Freq High</b>	400, 500, 630, 800, 1000, 1250, 1600, 2000, 2500, 3150, 4000, 5000, 6300, 8000 [Hz]	Sets the frequency separating the high-frequency range (HIGH) and midrange (MID).

### Common to High, Mid, and Low

Parameter	Value	Explanation
<b>Level</b>	0–24 dB (1 dB Step)	Output Level
<b>Attack Time</b>	0–100	Sets the time it takes until the level is compressed after the input exceeds the Threshold.
<b>Release Time</b>	0–100	Sets the time it takes for the compression to be released after the input falls below the Threshold.
<b>Threshold</b>	-60 dB–0 dB (1 dB Step)	Sets the level at which compression begins.
<b>Ratio</b>	1:1.0, 1:1.1, 1:1.2, 1:1.4, 1:1.6, 1:1.8, 1:2.0, 1:2.5, 1:3.2, 1:4.0, 1:5.6, 1:8.0, 1:16, 1:INF	Compression Ratio

### Live Set File Management (Live Set File)

A single, individual file containing a collection of 200 Live Sets registered to the RD-800 is called a “Live Set file.”

### Saving a Live Set File (Live Set File Save)

This Live Set file can be saved in the RD-800’s user memory or on a USB flash drive (sold separately) connected to the USB MEMORY/WLAN ADAPTOR port.

#### MEMO

The Live Set file will not save unsaved Live Sets or system parameter settings.

If you want to save these settings, you must first proceed as described in “Saving the Sound Settings in a Live Set (Live Set Write)” (p. 23) and “Saving System Settings” (p. 43).

1. In the MENU screen, select “Live Set File” and press the [ENTER] button (p. 26).
2. Press the Cursor [▲] buttons to select “Save,” then press the [ENTER] button.
3. Press the Cursor [◀] [▶] buttons to move the cursor to the positions where the characters are to be input.

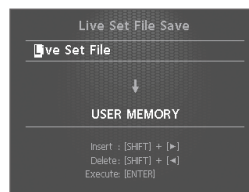

4. Use the [DEC] [INC] buttons or the value dial to enter the name.

Names can consist of up to 16 characters.

Operation	Explanation
[SHIFT] + [◀] button	Delete one character (DELETE)
[SHIFT] + [▶] button	Insert one space (INSERT)
[SHIFT] + [▲] button	Switch character sets
[SHIFT] + [▼] button	Switch uppercase/lowercase

#### NOTE

You can’t save a Live Set file with a name that starts with a “.” (period). Do not use a “.” (period) at the beginning of the name.

5. Repeat steps 3–4 to input the name.

- Move the cursor downward and select the destination for saving the Live Set file.

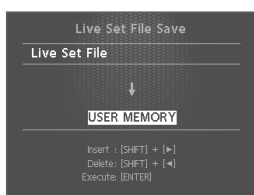

Value	Explanation
USER MEMORY	The data is stored in the RD-800's user memory.
USB MEMORY	The data is stored on a USB flash drive connected to the USB MEMORY/WLAN ADAPTOR port on the rear panel.

- Press the [ENTER] button.

The confirmation message appears.

If you do not want to load the Live Set file, press the [EXIT/SHIFT] button.

- Press the [ENTER] button once again to save the Live Set file.

The Live Set file is saved.

**NOTE**

- "Executing..." appears in the display while the save is in progress. Be sure never to turn off the power.
- Do not disconnect the USB flash drive while data is being saved.

**MEMO**

If a file with the same name has already been saved, the confirmation message "Overwrite OK?" appears. To overwrite the Live Set file, press the [ENTER] button; to save the file under a different name, press the [EXIT/SHIFT] button.

## Calling Up Live Set Files (Live Set File Load)

Here's how to load a previously saved Live Set file.

**NOTE**

The current settings are erased when a Live Set file is called up. Be sure to save any settings you would like to keep first before calling up a Live Set file (p. 23).

- In the MENU screen, select "Live Set File" and press the [ENTER] button (p. 26).
- Press the Cursor [▲] [▼] buttons to select "Load," then press the [ENTER] button.
- Move the cursor to "Media" and select the media (memory) from which the file is to be loaded.

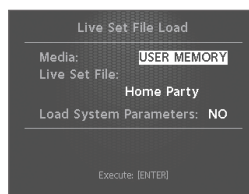

Value	Explanation
USER MEMORY	Data is loaded from the RD-800's user memory.
USB MEMORY	Data is loaded from the USB flash drive connected to the rear panel USB MEMORY/WLAN ADAPTOR port.

- Move the cursor to "Live Set File" and use the [DEC] [INC] buttons or the value dial to select the file you want to call up.
- If you want system parameter (p. 43) settings to also be loaded, move the cursor to "Load System Parameters" and choose "YES."

The system parameters are saved in a Live Set file that has been stored after the [WRITE] button was pressed to save the settings in the RD-800.

- Press the [ENTER] button.

The confirmation message appears.

If you decide to cancel without loading a Live Set file, press the [EXIT/SHIFT] button.

- Press the [ENTER] button once again to load the Live Set file.

The Live Set file is loaded into the RD-800.

**NOTE**

- Be sure never to turn off the power while the load is in progress.
- Do not disconnect the USB flash drive while the file is being loaded.

### Deleting a Live Set File (Live Set File Delete)

Here's how to delete a previously saved Live Set file.

1. In the MENU screen, select "Live Set File" and press the [ENTER] button.
2. Press the Cursor [▲] [▼] buttons to select "Delete," then press the [ENTER] button.
3. Move the cursor to "Media" and select the memory from which you want to delete a Live Set file.

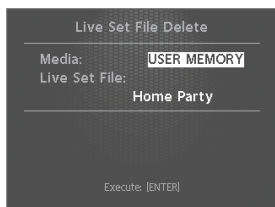

4. Move the cursor to "Live Set File" and use the [DEC] [INC] buttons or the value dial to select the Live Set file that you want to delete; then press the [ENTER] button.

The confirmation message appears.

If you decide to cancel without deleting the Live Set file, press the [EXIT/SHIFT] button.

#### MEMO

If you choose "ALL," all Live Set files will be deleted.

5. Press the [ENTER] button to delete the Live Set file.

#### NOTE

- Be sure never to turn off the power while the delete is in progress.
- Do not disconnect the USB flash drive while the file is being deleted.

### Copying a Live Set File (Live Set File Copy)

You can copy a Live Set file from the RD-800's user memory to a USB flash drive (sold separately).

You can also copy a Live Set file from a USB flash drive to the RD-800's internal memory.

1. In the MENU screen, select "Live Set File" and press the [ENTER] button.
2. Press the Cursor [▲] [▼] buttons to select "Copy," then press the [ENTER] button.
3. Use the [DEC] [INC] buttons or the value dial to select the copy-source media.

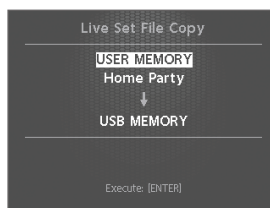

Parameter	Explanation
USER MEMORY	Copy from the RD-800's user memory to USB flash drive.
USB MEMORY	Copy from USB flash drive to the RD-800's user memory.

4. Press the [▼] button to move the cursor to the copy-source Live Set name.
5. Use the [DEC][INC] buttons or the value dial to select the copy-source Live Set file.

If you decide to cancel without copying the file, press the [EXIT/SHIFT] button.

#### MEMO

If you choose "ALL," all Live Set files will be copied.

6. Press the [ENTER] button to copy the Live Set file.

#### NOTE

- Be sure never to turn off the power while the copy is in progress.
- Do not disconnect the USB flash drive while data is being copied.

#### MEMO

If a file with the same name has already been saved, the confirmation message "Overwrite OK?" appears. To overwrite the Live Set file, press the [ENTER] button; to save the file under a different name, press the [EXIT/SHIFT] button.

## Convenient Functions (Utility)

1. Press the [MENU] button to select "Utility," and press the [ENTER] button.
2. Use the cursor buttons to select the item that you want to execute, and press the [ENTER] button.

## Disconnecting the Controller Section and the Sound Generator Section (Local Switch)

The switch that connects and disconnects the MIDI connection between the keyboard controller section and the sound generator section (p. 10) is called the Local switch. Since essential information describing what is being played on the keyboard won't reach the sound generator if the Local switch is set to OFF, the Local switch should normally be left ON.

However, if while performing you want to send that performance data to an external sequencer as MIDI messages to be recorded, you should then perform with the externally connected MIDI sequencer set to MIDI Thru (whereby data received from MIDI IN is then output from the MIDI OUT with no changes made to the data).

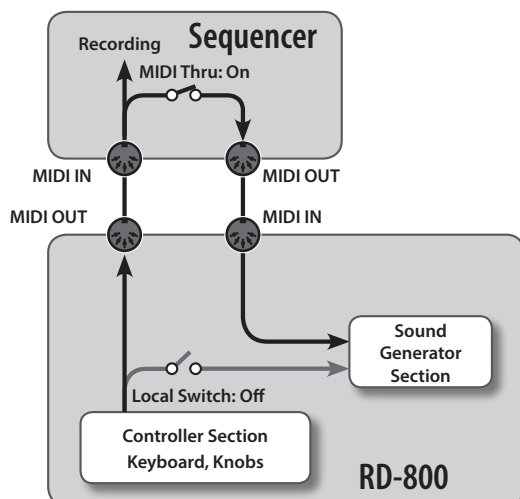

Parameter	Value
Local Switch	OFF, ON (ON when the system is started up)

## Optimizing Settings for Recording on an External Sequencer (Rec Mode)

"Rec Mode" is a convenient feature to use when recording to an external sequencer.

When using the Rec Mode function, you can get the most suitable settings for recording the RD-800's data to an external sequencer, without having to make all the Part and channel settings.

Parameter	Value
Rec Mode	OFF, ON (OFF when the system is started up)

Ordinarily, this should be set to OFF.

When this is set to ON, settings appropriate for recording are used with respect to the output from MIDI OUT, regardless of the INTERNAL layer settings.

### MEMO

If Rec Mode is ON, you can't change the EXTERNAL layer settings (p. 38) in the MIDI Control screen.

## Recording the Performance

1. Turn on the external sequencer's Thru function.
2. The following settings are made.

Parameter	Value
Rec Mode	ON
Local Switch	OFF

3. Record using your external sequencer.

## Formatting Memory (Format)

"Formatting" is the operation of deleting all Live Set files from user memory or initializing a USB flash drive so that it can be used with the RD-800.

A USB flash drive cannot be used with the RD-800 unless it is formatted suitably for the RD-800.

If you're using a newly purchased USB flash drive, you must first format it on the RD-800.

### NOTE

When you format the USB flash drive, all data previously saved on that media will be erased. Before you carry out a format, make sure that the USB flash drive does not contain important data you need to keep.

Parameter	Explanation
USER MEMORY	All Live Set files in the RD-800's user memory are deleted.
USB MEMORY	The USB flash drive connected to the rear panel USB MEMORY/WLAN ADAPTOR port is formatted.

For details, refer to "Formatting Memory (Format)" (p. 27).

### Restoring the Factory Settings (Factory Reset)

The settings stored in the RD-800 can be returned to their factory settings.

#### NOTE

- When you execute “Factory Reset All,” all Live Sets saved in banks A–J are returned to their factory settings. If you want to keep the stored content, save your Live Set files (p. 44).
- If you’re currently connected via USB, be absolutely sure to disconnect the USB cable before starting.

Parameter	Explanation
Factory Reset Current	The currently selected Live Set is returned to the factory settings.
Factory Reset All	All Live Sets and system settings in the RD-800 are returned to their factory-set state.

For details, refer to “Restoring the Factory Settings (Factory Reset)” (p. 27).

### Importing a Specific Live Set from a Live Set File (Live Set Import)

From a Live Set file that you saved, you can import a specific Live Set into the desired number.

#### NOTE

When you import a Live Set, the Live Set that had occupied the import-destination will be erased.

If you want to keep the stored content, save your Live Set files (p. 44).

1. Press the [MENU] button to select “Utility,” and press the [ENTER] button.
2. Use the cursor buttons to select the “Live Set Import,” and press the [ENTER] button.  
The Live Set file selection screen appears.
3. Move the cursor to “Media,” and use the [DEC] [INC] buttons or the value dial to select the memory from which you want to import.

Value	Explanation
USER MEMORY	Data is loaded from the RD-800’s user memory.
USB MEMORY	Data is loaded from the USB flash drive connected to the rear panel USB MEMORY/WLAN ADAPTOR port.

4. Move the cursor to “Live Set File,” and use the [DEC] [INC] buttons or the value dial to select the Live Set file that contains the Live Set you want to import; then press the [ENTER] button.  
The Live Set selection screen appears.
5. Use the [DEC] [INC] buttons or the value dial to select the Live Set that you want to import.
6. Press the cursor [▼] button.
7. Use the [DEC] [INC] buttons or the value dial to select the Live Set number into which you want to import the Live Set; then press the [ENTER] button.  
The confirmation message appears.

8. Press the [ENTER] button once again; the Live Set is imported.

If you decide to cancel, press the [EXIT/SHIFT] button.

#### NOTE

- Never turn off the power during execution.
- Do not disconnect the USB flash drive during execution.

### Initializing a Live Set (Live Set Initialize)

This lets you initialize the settings of the currently selected Live Set.

#### NOTE

When you initialize a Live Set, the currently selected Live Set will disappear.

If you want to keep the stored content, save your Live Set files (p. 44).

1. Press the [MENU] button to select “Utility,” and press the [ENTER] button.
2. Use the cursor buttons to select the “Live Set Initialize,” and press the [ENTER] button.  
The Live Set Initialize screen appears.
3. Press the [ENTER] button.  
The confirmation message appears.
4. Press the [ENTER] button once again to execute initialization.

If you decide to cancel, press the [EXIT/SHIFT] button.

#### NOTE

Never turn off the power during execution.

## About MIDI Visual Control (V-LINK/MVC)

### What is MIDI visual control?

MIDI Visual Control is an internationally used recommended practice that was added to the MIDI specification so that visual expression could be linked with musical performance. Video equipment that is compatible with MIDI Visual Control can be connected to electronic musical instruments via MIDI in order to control video equipment in tandem with a performance.



### What is V-LINK?

V-LINK is Roland's proprietary specification that allows visual expression to be linked with musical performance.



Video equipment that is compatible with V-LINK can be connected to electronic musical instruments via their MIDI ports, making it easy to enjoy a variety of visual effects that are linked with the performance.

### Connection examples

As an example, we will use a Live Set in which the RD-800 is connected to the P-10.

#### MEMO

In order to use MIDI Visual Control between the RD-800 and the P-10, you'll need to make connections using a MIDI cable (sold separately).

#### NOTE

Before connecting this unit to other devices, turn off the power to all units. This will help prevent malfunction and/or damage to speakers or other devices.

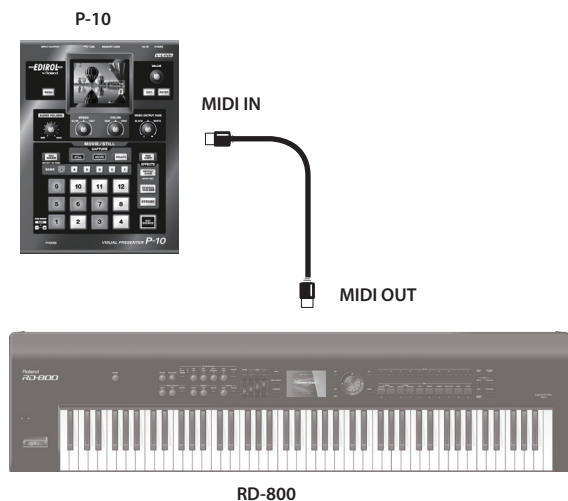

## Turning MIDI Visual Control ON/OFF

1. In the MENU screen, select "V-LINK/MVC" and press the [ENTER] button.

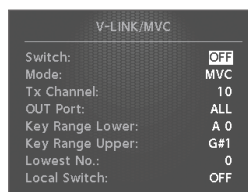

2. Select "V-LINK/MVC Switch" and change it to "ON."  
MIDI Visual Control will be on, allowing you to control images by your performance on the RD-800's keyboard.
3. Select "V-LINK/MVC Switch" and change it to "OFF."  
MIDI Visual Control will be turned off.

## MIDI Visual Control Settings

1. In the MENU screen, select "V-LINK/MVC" and press the [ENTER] button.
2. Select the parameter that you want to edit, and edit its value.

#### MEMO

If you want to save this settings, press the [WRITE] button. Settings saved in the RD-800 are not deleted even when the power is turned off. However, the MIDI VISUAL CONTROL on/off status is not memorized.

## Detailed Settings of MIDI Visual Control

Parameter	Value	Explanation
Switch	OFF, ON	Switches MIDI Visual Control on/off.
	MVC	MIDI Visual Control mode is selected.
Mode	V-LINK	V-LINK mode is selected.
Tx Channel	1-16	Selects the MIDI channel used in outputting messages.
OUT Port	ALL, OUT1, OUT2, USB	Selects the port used for outputting messages. If the System parameter "MIDI OUT2 MODE" setting (p. 41) is set to THRU, MIDI Visual Control data will not be transmitted even if you choose the OUT 2 setting.
Key Range Lower	A0-C8	Select the range of keys to use as the MIDI Visual Control controller.
Key Range Upper		
Lowest No.		Sets the number that is output when the lowest key in the range set with Key Range is pressed.

## Visual control function chart

The following MIDI messages are transmitted.

Visual Control Function	Transmitted MIDI Message	Operation on RD-800
Switch images	CC0 (Bank Select)	Play black keys
	Program Change	Play white keys

## Detailed Settings for Each Function

### V-LINK/MVC Local Switch

This setting determines whether or not the RD-800's sounds are played when a key within the range set with Key Range is pressed.

Parameter	Value	Explanation
Local Switch	OFF	No sounds are played, even when keys in the range set in Key Range are pressed.
	ON	Sounds are played when keys in the range set in Key Range are pressed.

### Wireless LAN Function Settings (Wireless)

By inserting the wireless USB Adapter (WNA1100-RL; sold separately) into the RD-800's USB MEMORY/WLAN ADAPTOR port, you'll be able to use wireless-compatible applications (such as the "Air Recorder" iOS app).

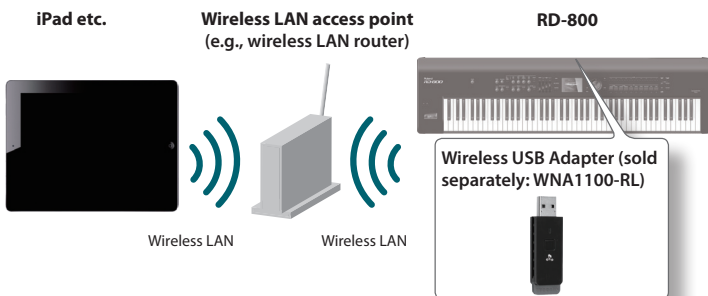

#### Items required to use the wireless LAN function

- Wireless USB Adapter (sold separately: WNA1100-RL)
- Wireless LAN access point (e.g., wireless LAN router) \*1 \*2 \*3
- iPad etc.

- \*1 The wireless LAN access point you use must support WPS. If your wireless LAN access point does not support WPS, you can connect using the procedure described in "Connecting to a Wireless LAN Access Point That You Select (Select Access Point)" (p. 51).
- \*2 The ability to connect with all kinds of wireless LAN access points is not guaranteed.
- \*3 If you're unable to connect to the wireless LAN access point, try connecting using Ad-Hoc mode (p. 52).
- \*4 Depending on the wireless LAN system that you're using, you might be unable to connect, or the connection might be dropped.
- \*5 Depending on the wireless device used by the wireless LAN function, noise might be heard from the RD-800. In this case, you may be able to improve the situation by moving the wireless device away from the RD-800, or by changing the wireless connection mode (WPS / ad-hoc mode).
- \*6 The sound and functionality might be temporarily affected while a connection is being established; this is not a malfunction.

### Basic Connection Method (Connect by WPS)

The first time you connect the RD-800 to a wireless network, you'll need to perform the following procedure (WPS) to join the wireless network.

This procedure is required only the first time. (Once you've joined the network, this procedure will no longer be necessary.)

#### What is WPS?

This is a standard that makes it easy to make security settings when connecting to a wireless LAN access point. We recommend that you use WPS when connecting to a wireless LAN access point.

1. Insert the wireless USB Adapter (WNA1100-RL; sold separately) into the RD-800's USB MEMORY/WLAN ADAPTOR port.
2. In the MENU screen, select "Wireless" and press the [ENTER] button.
3. Press the cursor [▲] [▼] buttons to select the "WPS," then press the [ENTER] button.  
The WPS screen appears.
4. Perform the WPS operation on your wireless LAN access point (e.g., press the WPS button on your wireless LAN access point).
5. Press the [ENTER] button of the RD-800.

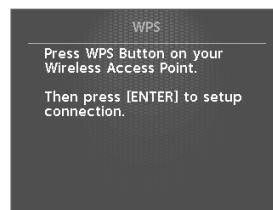

For details on WPS operation of your wireless LAN access point, refer to the documentation for your wireless LAN access point.

- Once successfully connected, "Completed" will appear.  
\* If you fail to connect, refer to "Troubleshooting" (p. 57).

#### NOTE

The device (e.g., iPad) running the app must be connected to the same network.

#### MEMO

- The connection data is stored in memory when you perform the WPS procedure; the device will automatically connect to the wireless network the next time.
- All connection data will be erased if you perform a factory reset.

### Icons in the display

The wireless LAN status is shown in the display.



Icon	Explanation
	Currently connected to the wireless LAN access point. Three bars are used to indicate the signal level (the strength of the connected wireless LAN access point's radio signal).
	The wireless USB adapter is inserted, but not connected with a wireless LAN access point.
	The wireless USB adapter is not inserted (nothing is displayed).
	Ad-Hoc mode (p. 52).

## Status Indication (Wireless)

This shows the wireless LAN status.

1. In the MENU screen, select "Wireless" and press the [ENTER] button.

The Wireless screen appears.

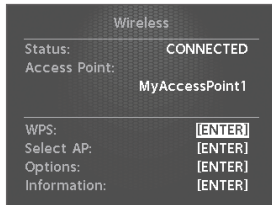

Display	Explanation
CONNECTED	Currently connected to the wireless LAN access point. The identifier (name) of the connected wireless LAN access point is shown.
NOW CONNECTING	A connection with the wireless LAN access point is being established.
NOT CONNECTED	The wireless USB adapter is inserted, but not connected to a wireless LAN access point.
NOT AVAILABLE	The wireless USB adapter is not inserted.
AD-HOC	Ad-Hoc mode. The Ad-Hoc SSID and Ad-Hoc Key are shown. For details, refer to "Connecting in Ad-Hoc mode" (p. 52).

## Connecting to a Wireless LAN Access Point That You Select (Select Access Point)

This method lets you connect by choosing a wireless LAN access point from the list that is displayed.

\* Wireless standards 802.11g/n (2.4 GHz) and authentication methods WPA/WPA2 are supported.

1. In the MENU screen, select "Wireless" and press the [ENTER] button.
2. Use the cursor [▲] [▼] buttons to select "Select AP," and press the [ENTER] button.

The Select Access Point screen appears.

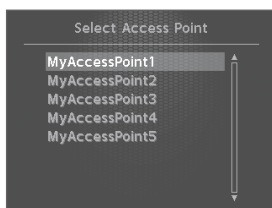

\* A "\*" symbol is shown for the currently-connected wireless LAN access point.

\* Names containing characters other than single-byte alphanumeric characters will not be displayed correctly.

3. Choose the wireless LAN access point to which you want to connect, and press the [ENTER] button.
  - You will be connected to the selected wireless LAN access point.
  - If you're using this wireless LAN access point for the first time, you'll proceed to the Authorization screen.
  - If this is a wireless LAN access point to which you have connected in the past, just press the [ENTER] button and you'll be connected. Once successfully connected, "Completed" will appear. Press the [EXIT/SHIFT] button to return to the status (Wireless) screen.

## Authorization screen

4. Enter the security code (Passphrase) of your wireless LAN access point, and press the [ENTER] button.

\* You cannot enter a space at the end of the passphrase.

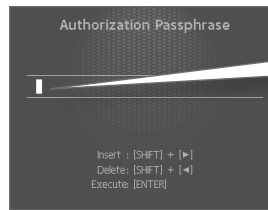

1. Use the cursor [◀] [▶] buttons to move the cursor to the position at which you want to enter a character.
2. Use the [DEC] [INC] buttons or the value dial to enter characters as necessary.

Operation	Explanation
[SHIFT] + [◀] button	Delete one character (DELETE)
[SHIFT] + [▶] button	Insert one space (INSERT)
[SHIFT] + [▲] button	Switch character sets
[SHIFT] + [▼] button	Switch uppercase/lowercase

Once successfully connected, return to the status (Wireless) screen.

## Other Settings (Wireless Options)

Make settings for Wireless ID or Ad-Hoc mode.

1. In the MENU screen, select "Wireless" and press the [ENTER] button.
2. Use the cursor [▲] [▼] buttons to select "Options," and press the [ENTER] button.

The Wireless Options screen appears.

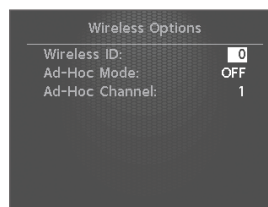

Parameter	Value	Explanation
Wireless ID	0-99	Specifies the final digits of the RD-800's device name and Ad-Hoc SSID ("RD-800") that will be shown as the instrument in the wirelessly connected app. Normally, you should specify "0," but if you have more than one of the same instrument, you can set the Wireless ID the range of 1-99 to change the device name and Ad-Hoc SSID for each instrument, as follows. If Wireless ID=0, "RD-800" (default value) If Wireless ID=1, "RD-800_1" : If Wireless ID=99, "RD-800_99"
Ad-Hoc Mode	OFF, ON	Turns Ad-Hoc mode On/Off.
Ad-Hoc Channel	1-11	Specifies the channel (1-11) for Ad-Hoc mode.

### Connecting in Ad-Hoc mode

Here's how to connect in Ad-Hoc mode.

#### What is Ad-Hoc mode?

Ad-Hoc mode lets you connect the RD-800 directly to an iPad or other wireless device without using a wireless LAN access point. This is a convenient way to use the RD-800 with an iPad or other wireless device if you're in a location where the wireless LAN access point you normally use is unavailable, such as when you're away from home.

iPad etc.



Wireless LAN

RD-800



Wireless USB Adapter (sold separately: WNA1100-RL)



#### Limitations

The iPad or other wireless device connected in Ad-Hoc mode will be unable to communicate with the Internet or with another wireless device. However, an iPad or other wireless device that has cellular capability will be able to connect to the Internet via the cellular connection.

Please be aware that if you use a cellular connection for Internet connectivity, you may incur costs depending on your rate plan.

1. In the MENU screen, select "Wireless" and press the [ENTER] button.
2. Use the cursor [▲] [▼] buttons to select "Options," and press the [ENTER] button.  
The Wireless Options screen appears.
3. Turn the Ad-Hoc Mode "ON."  
You can use Channel to specify a channel (1–11) for Ad-Hoc mode. Normally, you won't need to change the channel. Try changing the channel only if you have problems connecting.
4. Press the [EXIT/SHIFT] button to access the Wireless Status screen.

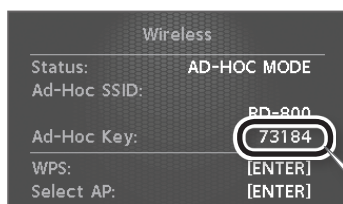

The Ad-Hoc key is the five-digit number that's displayed here. Each piano has its own unique number.

The Ad-Hoc SSID (RD-800) and the Ad-Hoc Key (a five-character text string) will be displayed.

#### MEMO

The Ad-Hoc SSID (RD-800) will be the value that you specified in the Wireless Options screen "Wireless ID" setting.

5. On the iPad or other wireless device that you want to connect, select the Ad-Hoc SSID shown in the Wireless Status screen to make the connection. (For example, on an iPad, choose [Settings] → [Wi-Fi] → [Choose a Network] to select the above Ad-Hoc SSID (RD-800). A password entry screen appears; enter the above Ad-Hoc key.)

For details on how to connect to a wireless LAN from an iPad or other device, refer to the owner's manual of that device.

6. When you have finished the Ad-Hoc mode connection, restore the iPad settings in [Settings] → [Wi-Fi] → [Choose a Network] to their previous state.

### Checking the IP Address and MAC Address (Wireless Information)

Here's how to check the IP address and MAC address.

1. In the MENU screen, select "Wireless" and press the [ENTER] button.
2. Use the cursor [▲] [▼] buttons to select "Information," and press the [ENTER] button.

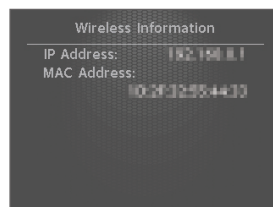

### Checking the MAC Address

The MAC address indicated on the bottom of the wireless USB adapter (WNA1100-RL; sold separately).



# Connecting to Your Computer

## Connecting to a Computer via the USB COMPUTER Port

If you use a USB cable (sold separately) to connect the USB COMPUTER port located on the RD-800's rear panel to the USB port of your computer, you'll be able to do the following things.

- Use the RD-800 to play SMF music files played back by MIDI compatible software.
- By transferring MIDI data between the RD-800 and your sequencer software, you'll be able to enjoy a wide range of possibilities for music production and editing.

### NOTE

Refer to the Roland website for system requirements.

Roland website:

<http://www.roland.com/>

Depending on the type of computer you're using, this may not operate correctly.

For details on supported operating systems, refer to the Roland website.

You can download the original driver from the Roland website.

Specify the USB driver you want to use, and then install the driver. For details, refer to "Switching USB Drivers" (p. 53).

### Caution

- To avoid the risk of malfunction and/or speaker damage, always make sure to turn the volume all the way down and turn off the power on all equipment before you make any connections.
- Only MIDI data can be transmitted and received via USB.
- A USB cable is not included. If you need to obtain one, ask the dealer where you purchased the RD-800.
- Switch on power to the RD-800 before you start up the MIDI application on your computer. Don't turn the RD-800 on/off while your MIDI application is running.

## Switching USB Drivers

The USB driver to be used when a computer is connected to the USB COMPUTER port is determined as follows:

1. Press the [MENU] button.
2. Press the Cursor [▲] [▼] buttons to select "System," and then press the [ENTER] button.
3. Press the Cursor [▲] [▼] buttons to move the cursor to "USB Driver."

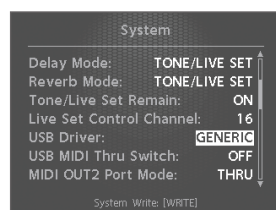

4. Use the [DEC] [INC] buttons or the value dial to select the USB driver you want to use.

Parameter	Value	Explanation
USB Driver	ORIGINAL	Choose this if you're using the USB driver downloaded from the Roland website.
	GENERIC	Choose this if you're using the default USB driver that came with your computer.

5. Press the [WRITE] button.

6. Turn the RD-800 off, then on again.

## Using the RD-800 As a USB MIDI Interface

If the RD-800 is connected to your computer, performance data from a MIDI device connected to the RD-800's MIDI IN connector can be sent to your computer.

Parameter	Value	Explanation
USB MIDI Thru Switch	OFF	Performance data from the device connected to the RD-800's MIDI IN connector will not be sent to your computer.
	ON	Performance data from the device connected to the RD-800's MIDI IN connector will be sent to your computer.

### What is the USB MIDI Driver?

The USB MIDI Driver is a software which passes data between the RD-800 and the application (sequencer software, etc.) that is running on the USB-connected computer.

The USB MIDI Driver sends data from the application to the RD-800, and passes data from the RD-800 to the application.

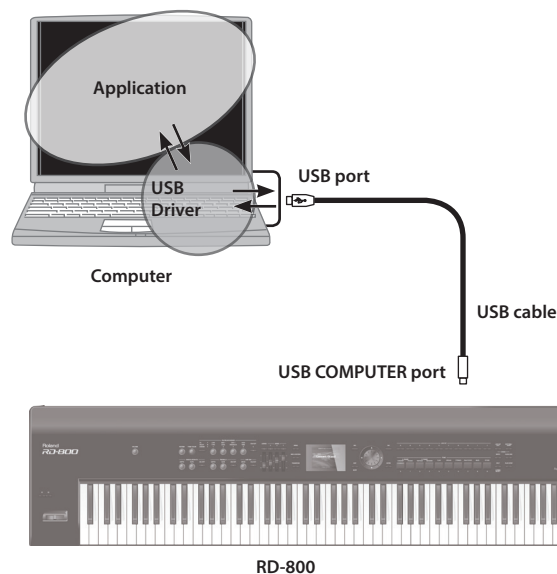

# Troubleshooting

If the RD-800 does not function in the way you expect, first check the following points. If this does not resolve the problem, consult the retailer from whom you purchased the instrument, or the nearest Roland Service Center.

\* If certain messages appear in the display during operation, please refer to "Error Messages" (p. 57).

Problem	Check/Solution	Page
<b>Power not coming on</b>	Is the RD-800's power cord properly plugged into a power source as well as connected to the RD-800?	p. 18
<b>Buttons don't work</b>	Could panel lock be active? Disable the panel lock setting.	p. 12
<b>No sound</b>	Is the power for connected amps and speakers turned on? Is the volume turned all the way down?	p. 19
	Is the [VOLUME] knob turned all the way down?	p. 16
	Are your amp, speakers, headphones, etc., connected correctly? Correctly connect your amp, speakers, and headphones.	p. 18
	Are sounds audible with headphones connected? If sounds are audible through headphones, it may indicate that there is a short in an audio cable or some sort of amp or mixer problem. Check the cables and equipment once again.	–
	Are LAYER switches set to OFF?	p. 12 p. 37
	Is a Part's volume turned off with the LAYER LEVEL slider?	p. 12 p. 37
	(If the sound for a pressed key is not being played) Is the Local Switch set to OFF? From MENU, go to Utility, and turn Local Switch ON.	p. 47
	Are the effect settings correct? Check the following settings. <ul style="list-style-type: none"> <li>• ON/OFF settings for Modulation FX</li> <li>• ON/OFF settings for Tremolo/Amp Simulator</li> <li>• Effect balance, level, etc.</li> </ul>	p. 14
	Could the volume have been lowered by a pedal operation (volume message or expression message)?	–
	Could the volume have been lowered by a MIDI message (volume message or expression message) received from an external MIDI device or from song data?	–
<b>No sound for specific layer</b>	Is the Layer's volume level turned down? Check the following settings. <ul style="list-style-type: none"> <li>• LAYER LEVEL sliders</li> <li>• Volume settings in Layer edit</li> <li>• Audio Volume settings</li> <li>• Rhythm Volume settings</li> </ul>	p. 12 p. 28 p. 43 p. 24
<b>No sound from the connected MIDI device</b>	Is the device enabled to transmit MIDI messages? Press the [MIDI CONTROL] button so the indicator is lit, and turn the LAYER switch on. MIDI messages cannot be transmitted if LAYER switch is set to OFF.	p. 26
	Is the MIDI Transmit channel of the RD-800's controller section matched to the connected MIDI device's MIDI Receive channel? Make the Ch (MIDI Transmit Channel) settings in the MIDI CONTROL screen.	p. 38
<b>No sound in a specific range</b>	Has the range in which sounds are to be played (the key range) been set? Check the following settings. <ul style="list-style-type: none"> <li>• LAYER EDIT settings for the key range of each layer (KR.LWR, KR.UPR)</li> <li>• Settings for the KR.LWR and KR.UPR Layers in the MIDI CONTROL screen</li> </ul>	p. 28 p. 39
	Certain Tones, such as Rhythm Sets and Bass Tones, can only sound within a limited range.	–
	Is MIDI VISUAL CONTROL switched on? Set Local ON/OFF to LOCAL ON under MIDI VISUAL CONTROL. Sounds can then be played on the keyboard even when MIDI VISUAL CONTROL is switched on.	p. 49
<b>Tones are altered</b>	Did you call up a Live Set? When a Live Set is called up, the current Tone, effect, and other settings are disabled, and the selected Live Set goes into effect. Resave required settings to a Live Set.	p. 13
	When a mono connection is used, the tone quality can vary depending on the tone selected and the register in which it is used. For optimal listening quality, connecting in stereo is recommended.	–
<b>Tone doesn't change/keyboard not switching to Split</b>	Is the [MIDI CONTROL] button lit? When the [MIDI CONTROL] button is lit, the external sound generator is controlled. To change the RD-800's Tones and make settings in Keyboard mode, you need to press the [MIDI CONTROL] button to extinguish.	p. 26
	Is the Layer containing the Tone you want to change set to ON?	p. 13
<b>Rhythm not sounding</b>	Could a song be playing?	p. 25

Problem	Check/Solution	Page
Effects not applied/effects sound wrong	Is a TW-Organ 1–10 Tone selected? Effects are applied differently to the Tone Wheel than they are with other effects. When Tone Wheel is selected for multiple Parts, it is applied to all the Parts.	–
	Is the Modulation FX set to OFF?	p. 14
	In some cases where the delay timing selected in the DELAY settings in Effects is set to a note value, the delay sound may not be heard. Either adjust the tempo or change the numerical value of the delay timing.	p. 31
No modulation when modulation lever is moved	Could you have selected an organ tone? For some of the organ tones, the modulation lever cannot be used to apply a modulation effect. For such tones, the modulation lever is used to switch the rotary effect between slow and fast.	p. 22
	Could you have selected the SuperNATURAL E. Piano sound? You can't apply modulation effects to the SuperNATURAL E. Piano sound.	–
Can't obtain pitch bend effect when the pitch bend lever is moved	Is the Harmonic Bar screen appearing in the display? The pitch bend effect cannot be applied with the pitch bend lever while the Harmonic Bar screen is in the display. In this case, the pitch bend lever functions as a slow/fast switch for the Rotary effect.	p. 22
Sounds come from left or right each time key is pressed (panned)	In some Tones, the settings are such that sounds randomly play from the left or right side (are panned) each time the keys are pressed. These settings cannot be changed.	–
Sound is distorted	Sounds can be distorted due to equalizer, multi-effect, and Part volume settings. Adjust the following settings. • LAYER LEVEL sliders • Equalizer Input Gain settings • [DRIVE] knob (AMP SIM section)	p. 12 p. 15
	Is a distortion-type effect being applied to the sound?	–
Key Range settings not effective	Is the [SPLIT] button set to OFF? Key Range goes into effect when the [SPLIT] button set to ON.	p. 13 p. 28
Pitch is odd	Depending on the Tone selected, pitches played in certain registers will be changed and played at other pitches.	–
	Is Coarse Tune or Fine Tune set for any specific Layer? Check the following settings. • Layer EDIT Coarse Tune, Fine Tune • Coarse Tune and Fine Tune setting in MIDI CONTROL screen	p. 28 p. 39
	Has the RD-800 gone out of tune? Check the following settings. • System Master Tune settings • System Temperament settings • Tuning settings in Individual Note Voicing	p. 40 p. 42 p. 34
	Has the pitch been changed by pedal operations or by Pitch Bend messages received from an external MIDI device?	–
	Have you set Transpose?	p. 12
	Could layer transpose settings have been made?	p. 28
Sound is cut off	When you try playing more than the maximum 128 voices simultaneously, sounds currently being played may be cut off. Increase the Voice Reserve settings for the Parts you do not want to have cut off.	p. 28
Sound continues even after removing fingers from keys	Is the pedal polarity reversed? Check the System Pedal Polarity settings.	p. 42
Exclusive messages cannot be received	Is the Device ID number of the transmitting device matched to the RD-800's Device ID number? Make sure that the transmitting unit is set to Device ID number 17.	–
Song data not played back correctly	Is the audio data playable? Make sure that the audio data can be played by the RD-800.	p. 25
EQ settings don't change when you switch Live Sets	Could the EQ Mode be set to "REMAIN"? Change the setting to "LIVE SET."	p. 40
Pedal settings don't change when you switch tones or Live Sets	Could the Pedal Mode be set to "REMAIN"? Change the setting to "TONE/LIVE SET." * However, the pedal settings won't change if you've switched tones via MIDI or in the LAYER EDIT screen.	p. 40
[S1] [S2] button settings don't change when you switch tones or Live Sets	Could the S1/S2 Mode be set to "REMAIN"? Change the setting to "TONE/LIVE SET." * However, the [S1] [S2] button settings won't change if you've switched tones via MIDI or in the LAYER EDIT screen.	p. 40
Assign 1–5 settings don't change when you switch tones or Live Sets	Could the Assign 1-5 Mode be set to "REMAIN"? Change the setting to "TONE/LIVE SET." * However, the Assign 1–5 settings won't change if you've switched tones via MIDI or in the LAYER EDIT screen.	p. 40
Delay settings don't change when you switch tones or Live Sets	Could the Delay Mode be set to "REMAIN"? Change the setting to "TONE/LIVE SET." * However, the delay settings won't change if you've switched tones via MIDI or in the LAYER EDIT screen.	p. 40

## Troubleshooting

Problem	Check/Solution	Page
Reverb settings don't change when you switch tones or Live Sets	Could the Reverb Mode be set to "REMAIN"? Change the setting to "TONE/LIVE SET." * However, the reverb settings won't change if you've switched tones via MIDI or in the LAYER EDIT screen.	p. 41
Pitch bend / modulation lever does not work.	Is there a check mark for the Pitch Bend Control Switch or Modulation Control Switch setting of the layer (or external layer) that you want to control? Add a check mark to the Pitch Bend Control Switch and Modulation Control Switch settings of the layer (or external layer) that you want to control.	p. 28 p. 39
Pedal does not work	Is the desired function assigned to the FC1/FC2/EXT pedal? Assign the desired function to the pedal.	p. 29
	Is the Damper/FC1/FC2/EXT Control Switch setting checked for the layer (or External layer) to which you want the effect to apply? Add a check mark to the Damper/FC1/FC2/EXT Control Switch setting for the layer (or External layer) to which you want the effect to apply.	p. 28 p. 39
[S1] [S2] buttons don't work	Is the desired function assigned to the [S1] [S2] buttons? Assign the desired function to the [S1] [S2] buttons.	p. 30
	Is the S1 (S2) Control Switch setting checked for the layer (or External layer) to which you want the effect to apply? Add a check mark to the S1 (S2) Control Switch setting for the layer (or External layer) to which you want the effect to apply.	p. 28 p. 39
Assign 1-5 controllers don't work	Is the desired function assigned to the Assign 1-5 controllers? Assign the desired function to the Assign 1-5 controllers.	p. 30
	Is the Assign 1-5 Control Switch setting checked for the layer (or External layer) to which you want the effect to apply? Add a check mark to the Assign 1-5 Control Switch setting for the layer (or External layer) to which you want the effect to apply.	p. 28 p. 39
MODULATION FX [DEPTH] [RATE] knobs and [ON/OFF] button do not affect the layer you intend	Have you selected the layer to which you want the effect to apply? In the Modulation FX Control Destination settings, select the layer to which you want the effect to apply.	p. 28
TREMOLO [DEPTH] [RATE] knobs and [ON/OFF] button, and AMP SIM [DRIVE] knob and [ON/OFF] button do not affect the layer you intend	Have you selected the layer to which you want the effect to apply? In the Tremolo/Amp Control Destination settings, select the layer to which you want the effect to apply.	p. 28
[Tone Color] knob does not affect the layer you intend	Have you selected the layer to which you want the effect to apply? In the Tone Color Control Destination settings, select the layer to which you want the effect to apply.	p. 28
Screen display is irregular when RD-800 is turned on/off	This is due to the nature of an LCD screen; it does not indicate a malfunction.	–
A dot in the LCD is missing (a specific pixel remains unlit)	In order to display high-quality images, the RD-800 uses a TFT liquid crystal display. Due to its characteristics, a TFT liquid crystal screen may contain pixels that do not light or that remain lit; please be aware that this is not a malfunction or defect.	–
Pedal does not work, or is "stuck"/Pedal does not operate correctly	Is the pedal connected correctly? Plug the cord firmly into the pedal jack.	p. 18
	Are you using a pedal made by another manufacturer? Use the included pedal or a separately sold RPU-3 or EV-5	p. 18
Can't read or write user memory or a USB flash drive	Are you using (optional) Roland USB flash drive? Reliable performance cannot be guaranteed if you use non-Roland USB flash drive products.	–
	Execute the Format operation. * This will erase all of the saved content.	p. 27
Reverberation remains even if you defeat the Reverb effect	The RD-800's piano sound faithfully simulates the depth and resonance of an acoustic piano, and this may give the impression of reverberation even if you've defeated the Reverb effect.	–
The sound of the higher notes suddenly changes from a certain key	On an acoustic piano, the approximately one and a half octaves of notes at the upper end of the keyboard will continue sounding regardless of the damper pedal. These notes also have a somewhat different timbre. The RD-800 faithfully simulate this characteristic of acoustic pianos. On the RD-800, the range that is unaffected by the damper pedal will change according to the key control setting.	–
High-pitched ringing is heard	Piano sounds that have a brilliant and crisp character contain substantial high-frequency components that may sound as though a metallic ringing has been added. This is because the characteristics of an actual piano are being faithfully reproduced; it does not indicate a malfunction. You can adjust this ringing by editing the following settings. <ul style="list-style-type: none"> <li>• Duplex scale settings (p. 32)</li> <li>• String resonance settings (p. 32)</li> <li>• Reverb level (p. 31)</li> </ul>	–
Low notes sound wrong, or are buzzy	With certain tones, the sounds may seem to be distorted. Turn down the volume. Alternatively, lower the master gain setting.	–
The volume level of the instrument connected to INPUT jack is too low.	Could you be using a connection cable that contains a resistor? Use a connection cable that does not contain a resistor.	–

Problem	Check/Solution	Page
Can't connect to a wireless LAN access point	Make sure that your wireless LAN access point supports WPS. If your wireless LAN access point does not support WPS, you can connect using the procedure described in "Connecting to a Wireless LAN Access Point That You Select (Select Access Point)" (p. 51).	p.50–p.52
	The 802.11a/b wireless standard is not supported. Please use the 802.11g/n (2.4 GHz) wireless standard.	
	The WEP authentication method is not supported. Please use the WPA or WPA2 authentication method.	
	Make sure that DHCP is enabled for your wireless LAN access point.	
	If you don't get connected to the previously-connected wireless LAN access point when you turn on the unit, check and make sure the setting described in "Connecting in Ad-Hoc mode" (p. 52) is OFF.	
	The connection might not occur successfully due to the state of the radio signal. If so, use the procedure described in "Connecting to a Wireless LAN Access Point That You Select (Select Access Point)" (p. 51), and select your wireless LAN access point and reconnect.	
The display indicates "Access Point Not Supported," and you can't connect to the wireless LAN access point	There is a limit to the connection data that can be remembered. Making a new connection may cause older connection data to be deleted. All connection data will be deleted if you execute a factory reset. If the connection data has been deleted, please re-connect to the wireless LAN access point.	
	This Access Point is not supported. Please use the WPA or WPA2 authentication method.	
Communication is unstable	Communication may be unstable depending on the usage of the radio frequency spectrum. If communication is unstable, the response may be sluggish, or if using audio communication, there may be dropouts in the audio. The following actions may improve the situation. <ul style="list-style-type: none"> <li>• Move the wireless LAN access point and the RD-800 closer to each other.</li> <li>• Change the channel setting of the wireless LAN access point.</li> </ul>	
The RD-800 is not found by the application (e.g., the iOS application Air Recorder) in its musical instrument connections	<ul style="list-style-type: none"> <li>• Is the RD-800 powered up?</li> <li>• Is the wireless USB adapter (WNA1100-RL) inserted into the RD-800?</li> <li>• Is the RD-800 connected to the wireless LAN?</li> <li>• Are the RD-800 and the iPad connected to the same network (the same wireless LAN access point)?</li> <li>• Is the wireless LAN access point set to allow communication between wireless LAN devices? For details on settings, refer to the owner's manual of your wireless LAN access point.</li> </ul>	

## Error Messages

If an incorrect operation is performed, or if processing could not be performed as you specified, an error message appears. Refer to the explanation for the error message that appears, and take the appropriate action.

Message	Meaning	Action
<b>Incorrect File!</b>	This is a file that the RD-800 is unable to play.	Select a file that is supported by the RD-800 (p. 25).
<b>MIDI Buffer Full!</b>	An unusually large amount of MIDI data was received, and could not be processed.	Reduce the amount of MIDI messages that are being transmitted.
<b>MIDI Offline!</b>	The MIDI IN connection was broken.	Check that there is no problem with the MIDI cable connected to the RD-800's MIDI IN, and that the MIDI cable was not disconnected.
<b>Read Error!</b>	Data could not be read from the USB flash drive.	Make sure that the USB flash drive is correctly connected (p. 24). Also make sure that you're using a USB flash drive sold by Roland.
	The file is damaged.	Do not use this file.
<b>System Memory Damaged!</b>	The contents of system memory may be damaged.	Execute the factory reset operation (p. 27). If this does not solve the problem, contact your dealer or customer support.
<b>Memory Full!</b>	There is insufficient space on the user memory or the USB flash drive.	Delete unneeded data (p. 27, p. 46).
<b>USB Memory Not Ready!</b>	The USB flash drive is not inserted, or is inserted incompletely.	Turn off the power, firmly insert the USB flash drive, and then turn on the power once again (p. 24).
	The USB flash drive was removed after you selected data that was on the USB flash drive.	
	The format of the USB flash drive is invalid.	Use the RD-800 to format the USB flash drive (p. 27).
<b>Write Error!</b>	Data could not be written to the USB flash drive.	Make sure that USB flash drive is correctly connected (p. 24). Also make sure that you're using a USB flash drive sold by Roland.
	The format of the USB flash drive is invalid.	Use the RD-800 to format the USB flash drive (p. 27).
<b>Access Point Not Supported</b>	This access point is not supported.	Please use the WPA or WPA2 authentication method.
<b>Duplicate File Name!</b>	When executing Song Rename, you specified a name that was identical to an existing file.	Specify a different file name (p. 25).

# Effect List

## Modulation FX

FILTER	
1	EQUALIZER
2	SPECTRUM
3	LOW BOOST
4	STEP FILTER
5	ENHANCER
6	AUTO WAH
7	HUMANIZER
MODULATION	
8	PHASER 1
9	PHASER 2
10	PHASER 3
11	STEP PHASER
12	MULTI STAGE PHASER
13	INFINITE PHASER
14	RING MODULATOR
15	TREMOLO
16	AUTO PAN
17	SLICER
CHORUS	
18	CHORUS
19	FLANGER
20	STEP FLANGER
21	HEXA-CHORUS
22	TREMOLO CHORUS
23	SPACE-D
DYNAMICS	
24	OVERDRIVE
25	DISTORTION
26	T-SCREAM
27	COMPRESSOR
28	LIMITER
29	SUSTAINER
30	GATE
DELAY	
31	DELAY
32	MODULATION DELAY
33	3TAP PAN DELAY
34	4TAP PAN DELAY
35	MULTI TAP DELAY
36	REVERSE DELAY
37	TIME CTRL DELAY
38	TAPE ECHO
LO-FI	
39	LOFI COMPRESS
40	BIT CRUSHER
PITCH	
41	PITCH SHIFTER
42	2VOICE PITCH SHIFTER

COMBINATION	
43	OD → CHORUS
44	OD → FLANGER
45	OD → DELAY
46	DS → CHORUS
47	DS → FLANGER
48	DS → DELAY
49	OD/DS → TWAH
50	OD/DS → AWAH
51	ENHANCER → CHORUS
52	ENHANCER → FLANGER
53	ENHANCER → DELAY
54	CHORUS → DELAY
55	FLANGER → DELAY
56	CHORUS → FLANGER

## Tremolo/Amp simulator

1	NORMAL
2	A. PIANO
3	E. PIANO
4	GUITAR AMP
5	ROTARY

## Delay

1	DELAY
2	T-CTRL DELAY
3	DELAY → TREMOLO
4	2TAP DELAY
5	3TAP DELAY

## Reverb

1	ROOM 1
2	ROOM 2
3	HALL 1
4	HALL 2
5	PLATE
6	GM2 REVERB

# Main Specifications

## Roland RD-800: Digital Piano

Keyboard Section	
	88 keys (PHA-4 Concert Keyboard: with Escape-ment and Ebony/Ivory Feel)
Sound Generator Section	
Maximum Polyphony	128 voices
Parts	16 parts (4 parts are used in the live set)
Sound Generator	SuperNATURAL Piano SuperNATURAL (E.Piano, Clav) Virtual Tone Wheel Organ PCM Sound Generator
Tones	1,113 tones
Live Sets	200
Piano Designer (adjustable in individual notes, Only for SuperNATURAL Piano)	Tone Color: 0–127 Nuance: TYPE1–TYPE3 Damper Noise: 0–127 Duplex Scale: 0–127 String Resonance: 0–127 Key Off Resonance: 0–127 Hammer Noise: -2–+2 Character: -5–+5 Sound Lift: 0–127
Individual Note Voicing (adjustable in individual notes)	Tuning: -50.0–+50.0 cent Level: -50–0 Character: -5–+5
Effects	Modulation FX: 4 systems, 56 types Tremolo/Amp Simulator: 4 systems, 5 types Reverb: 6 types Delay: 5 types Sympathetic Resonance (Only for SuperNATURAL Piano) 3-band Compressor 5-band Digital Equalizer
Audio File Player	
File Format	Audio Files (WAV format, 44.1 kHz, 16-bit linear)
Recorder Section	
File Format	Audio Files (WAV format, 44.1 kHz, 16-bit linear)

Other	
Rhythm Pattern	200 patterns
Controllers	LAYER LEVEL slider x 4 EQUALIZER/DELAY/ASSIGNABLE knobs x 4 (with illumination) REVERB knob (with illumination) TONE COLOR knob (with illumination) MODULATION FX DEPTH knob (with illumination) MODULATION FX RATE knob (with illumination) TREMOLO DEPTH knob (with illumination) TREMOLO RATE knob (with illumination) AMP SIMULATOR DRIVE knob (with illumination) Pitch Bend/Modulation lever S1/S2 Buttons (Assignable)
Display Theme	3 themes
Display	Graphic color LCD 320 x 240 dots
Connectors	OUTPUT (L/MONO, R) jacks: 1/4-inch phone type OUTPUT (L, R) jacks: XLR type INPUT jack: Stereo miniature phone type PEDAL (DAMPER, FC1, FC2, EXT) jacks: TRS phone type MIDI (IN, OUT1, THRU/OUT2) connectors USB (COMPUTER) port: USB type B USB (MEMORY/WLAN ADAPTOR) port: USB type A PHONES jack: Stereo 1/4 inch phone type AC In jack
Power Consumption	12 W
Dimensions	1,400 (W) x 366 (D) x 138 (H) mm 55-1/8 x 14-7/16 x 5-7/16 inches
Weight	21.7 kg 47 lbs 14 oz * Actual weight can vary slightly from that indicated due to the fact that wooden parts are involved.
Accessories	Owner's manual Power cord Damper pedal (capable of continuous detection) Cord clamp
Options	Keyboard stand: KS-G8, KS-G8B Piano pedal: RPU-3 Damper pedal: DP-10 Pedal switch: DP-2 Expression pedal: EV-5, EV-7 USB Flash Memory * Wireless USB Adapter * * Use USB Flash Memory and Wireless USB Adapter sold by Roland. We cannot guarantee operation if other products are used.

\* In the interest of product improvement, the specifications and/or appearance of this unit are subject to change without prior notice.

## Anchoring the Power Cord (Cord Clamp)

As necessary, the supplied cord clamp can be used to anchor the power cord. Affix the cord clamp at the location shown in the figure.

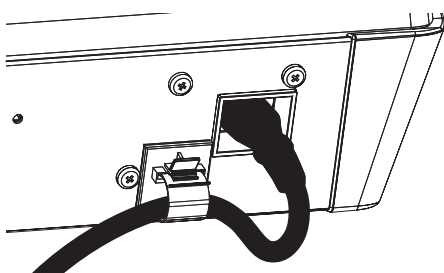

# Index

[☺] switch..... 18

## A

AC IN jack..... 18  
Ad-Hoc mode..... 52  
AMP SIM..... 14  
Assign..... 15  
Assign 1-5..... 30  
Assign 1-5 Mode..... 40  
Assign 1 Control Switch..... 28, 39  
Assign 2 Control Switch..... 28, 39  
Assign 3 Control Switch..... 28, 39  
Assign 4 Control Switch..... 28, 39  
Assign 5 Control Switch..... 28, 39  
Attack Time Offset..... 34, 39  
Audio..... 24  
Audio Files..... 25  
Audio Volume..... 43  
Auto Off..... 19, 27, 43

## B

Bank Select LSB..... 38  
Bank Select MSB..... 38

## C

Character..... 32  
Chorus Send Level..... 38  
Clock Out..... 42  
Coarse Tune..... 28, 39  
Controller Section..... 10  
Cursor buttons..... 17  
Cutoff Offset..... 34, 39

## D

Damper..... 35  
Damper Control Switch..... 28, 39  
Damper Noise..... 32, 33  
Damper Offset..... 35  
Decay Time Offset..... 34, 39  
[DEC] button..... 9, 17  
Delay..... 15, 31  
Delay Mode..... 40  
Delay Send Level..... 28  
Demo Song..... 19  
Depth..... 35  
Designer..... 21, 32  
Display..... 17  
Display Theme..... 43  
Duplex Scale..... 32

## E

EDITED symbol..... 21, 28, 32  
Effect Section..... 10  
[ENTER] button..... 17  
EQ Mode..... 40  
EQUALIZER..... 15  
[EXIT/SHIFT] button..... 17  
EXT Pedal Control Switch..... 28, 39

## F

Factory Reset..... 27  
FC1 Control Switch..... 28, 39  
FC2 Control Switch..... 28, 39  
Feet..... 22  
Fine Tune..... 28, 39  
Format..... 27  
Func..... 29, 30

## H

Hammer Noise..... 32  
Harmonic bars..... 22  
HF Damp Freq..... 35  
Hi-Res Velocity Out..... 43  
Hum Noise..... 33

## I

[INC] button..... 9, 17

Individual Note Voicing..... 34  
INPUT jack..... 18

## K

Keyboard Range Lower..... 28, 39  
Keyboard Range Upper..... 28, 39  
Key Off Position..... 29  
Key Off Resonance..... 32, 33  
Key Range Lower  
V-LINK/MVC..... 49  
Key Range Upper  
V-LINK/MVC..... 49  
Key Touch..... 29  
Key Touch Mode..... 41  
Key Touch Offset..... 29  
Knob LED Switch..... 43

## L

Layer..... 13  
Layer Edit..... 28  
LAYER LEVEL Slider..... 12  
LAYER Switch..... 12  
Layer Transpose..... 28, 38  
LCD Brightness..... 43  
Level..... 31, 35  
LF Damp Freq..... 35  
Live Set..... 10  
LIVE SET button..... 13  
Live Set Control Channel..... 41  
Live Set Edit..... 21, 28  
[LIVE SET EDIT] button..... 21  
Live Set File..... 44  
Live Set File Copy..... 46  
Live Set File Delete..... 46  
Live Set File Load..... 45  
Live Set File Save..... 44  
Live Set screen..... 9  
Live Set Swap..... 23  
Live Set Write..... 23  
Local Switch..... 47  
V-LINK/MVC..... 50  
Lowest No.  
V-LINK/MVC..... 49

## M

Master Keyboard..... 37  
Master Tune..... 40  
Mechanical Key Off Noise..... 33  
Mechanical Key On Noise..... 33  
[MENU] button..... 26  
Menu Screens..... 26  
MIDI connectors..... 18  
MIDI OUT2 Port Mode..... 41  
MIDI OUT Port..... 38  
MIDI Transmit Channel..... 38  
MIDI Tx Channel..... 38  
MIDI Visual Control..... 49  
Mode  
V-LINK/MVC..... 49  
Modulation..... 12  
Modulation Control Switch..... 28, 39  
Modulation Depth..... 39  
Modulation FX..... 35  
MODULATION FX..... 14  
Modulation FX Control Destination..... 28  
Mono..... 38  
Mono/Poly..... 33

## N

Nuance..... 32

## O

OUT Port  
V-LINK/MVC..... 49  
OUTPUT jacks..... 18

## P

Pan..... 28, 38  
Panel Lock..... 12  
Part Switch..... 42  
Peaking Freq..... 35  
Peaking Gain..... 35  
Peaking Q..... 35  
Pedal..... 29  
PEDAL jacks..... 18  
Pedal Mode..... 40  
Pedal Polarity..... 42  
PHONES jack..... 18  
Piano Designer..... 32  
Pitch bend..... 12  
Pitch Bend Control Switch..... 28, 39  
Pitch Bend Range..... 33, 39  
Poly..... 38  
Portamento Switch..... 33, 39  
Portamento Time..... 33, 39  
Pre HPF..... 35  
Pre LPF..... 35  
Preset memory..... 11  
Program Change..... 38

## R

Range Max..... 29, 30  
Range Min..... 29, 30  
Rec Mode..... 47  
Recording..... 24  
Release Time Offset..... 34, 39  
Resonance Offset..... 34, 39  
Reverb..... 14, 31  
[REVERB] knob..... 14  
Reverb Mode..... 41  
Reverb Send Level..... 28, 38  
Rhythm..... 24  
Pattern..... 24  
Tempo..... 24  
Volume..... 24  
Rhythm MIDI Out Channel..... 43  
Rhythm MIDI Output Port..... 43  
Rhythm Mode..... 41  
[RHYTHM/SONG] button..... 24  
Routing..... 35

## S

S1 Control Switch..... 28, 39  
S1/S2..... 30  
S1/S2 Mode..... 40  
S2 Control Switch..... 28, 39  
Select Access Point..... 51  
Select Button Mode..... 40  
Setting Parameters..... 40  
Sound Generator..... 10  
Sound Lift..... 32, 33  
Split..... 13  
[SPLIT] button..... 13  
Stand..... 8  
String Resonance..... 32  
Switch  
Modulation FX..... 35  
Sympathetic Resonance..... 35  
V-LINK/MVC..... 49  
Switch images  
V-LINK/MVC..... 49  
Switch Type..... 30  
Sympathetic Resonance..... 35  
System..... 40  
System Compressor..... 44  
System memory..... 11  
System setting  
Save..... 43

## T

Temperament/Key..... 42

Temporary area..... 11  
Tone..... 10  
TONE button..... 13  
TONE buttons  
Numeric Keys..... 9  
Tone Color..... 20, 32, 33  
Tone Color Control Destination..... 28  
[TONE COLOR] knob..... 20  
Tone Designer..... 33  
Tone/Live Set Remain..... 41  
Tone screen..... 9  
Transpose..... 12  
[TRANPOSE] button..... 12  
TREMOLLO..... 14  
Tremolo/Amp Control Destination..... 28  
Tremolo/Amp Simulator..... 35  
Tx Channel  
V-LINK/MVC..... 49  
Type..... 34  
Delay..... 31  
Modulation FX..... 35  
Reverb..... 31  
Tremolo/Amp Simulator..... 35

## U

USB COMPUTER Port..... 53  
USB Driver..... 41, 53  
USB flash drive..... 11, 24  
USB MEMORY/WLAN ADAPTOR  
port..... 18  
USB MIDI Thru Switch..... 41  
User Control Change 1 Number..... 39  
User Control Change 1 Value..... 39  
User Control Change 2 Number..... 39  
User Control Change 2 Value..... 39  
User memory..... 11  
Utility..... 47

## V

Value..... 34  
Value dial..... 9, 17  
Velocity..... 29  
Velocity Max..... 28  
Velocity Range Lower..... 28, 39  
Velocity Range Upper..... 28, 39  
Velocity Sensitivity..... 28  
Velo Delay Sens..... 29  
Velo Key Follow Sens..... 29  
Vibrato Delay Offset..... 34  
Vibrato Depth Offset..... 34  
Vibrato Rate Offset..... 34  
V-LINK/MVC..... 49  
Voice Reserve..... 28  
Volume..... 28, 38  
[VOLUME] knob..... 16

## W

Wireless..... 50, 51  
Wireless Information..... 52  
Wireless Options..... 51  
WPS..... 50

# Information

When you need repair service, call your nearest Roland Service Center or authorized Roland distributor in your country as shown below.

## AFRICA

### REUNION

**MARCEL FO-YAM Sarl**  
25 Rue Jules Hermann,  
Chaudron - BP79 97 491  
Ste Clotilde Cedex,  
REUNION ISLAND  
TEL: (0262) 218-429

### SOUTH AFRICA

**Paul Bothner(PTY)Ltd.**  
Royal Cape Park, Unit 24  
Londonderry Road, Ottery 7800  
Cape Town, SOUTH AFRICA  
TEL: (021) 799 4900

## ASIA

### CHINA

**Roland Shanghai Electronics Co.,Ltd.**  
5F, No.1500 Pingliang Road,  
Yangpu Shanghai 200090, CHINA  
TEL: (021) 5580-0800  
Toll Free: 4007-888-010

### Roland Shanghai Electronics Co.,Ltd. (BEIJING OFFICE)

3F, Soluxe Fortune Building  
63 West Dawang Road,  
Chaoyang Beijing, CHINA  
TEL: (010) 5960-2565/0777  
Toll Free: 4007-888-010

### HONG KONG

**Tom Lee Music**  
11/F Silvercord Tower 1  
30 Canton Rd  
Tsimshatsui, Kowloon,  
HONG KONG  
TEL: 852-2737-7688

### Parsons Music Ltd.

8th Floor, Railway Plaza, 39  
Chatham Road South, T.S.T,  
Kowloon, HONG KONG  
TEL: 852-2333-1863

### INDIA

**Rivera Digitec (India) Pvt. Ltd.**  
411, Nirman Kendra Mahalaxmi  
Flats Compound Off. Dr. Edwin  
Moses Road, Mumbai-400011,  
INDIA  
TEL: (022) 2493 9051

### INDONESIA

**PT. Citra Intirama**  
Ruko Garden Shopping Arcade  
Unit 8 CR, Podomoro City  
Jl.Jetjend. S.Parmar Kav.28  
Jakarta Barat 11470, INDONESIA  
TEL: (021) 5698-5519/5520

### KAZAKHSTAN

**Alatau Dybystary**  
141 Abylai-Khan ave, 1st floor,  
050000 Almaty, KAZAKHSTAN  
TEL: (727) 2725477  
FAX: (727) 2720730

### KOREA

**Cosmos Corporation**  
27, Banpo-daero, Seocho-gu,  
Seoul, KOREA  
TEL: (02) 3486-8855

### MALAYSIA/SINGAPORE

**Roland Asia Pacific Sdn. Bhd.**  
45-1, Block C2, Jalan PJU 1/39,  
Dataran Prima, 47301 Petaling  
Jaya, Selangor, MALAYSIA  
TEL: (03) 7805-3263

### PHILIPPINES

**G.A. Yupangco & Co. Inc.**  
339 Gil J. Puyat Avenue  
Makati, Metro Manila 1200,  
PHILIPPINES  
TEL: (02) 899 9801

### TAIWAN

**ROLAND TAIWAN ENTERPRISE CO., LTD.**  
9F-5, No. 112 Chung Shan  
North Road Sec. 2 Taipei 104,  
TAIWAN R.O.C.  
TEL: (02) 2561 3339

## THAILAND

**Theera Music Co., Ltd.**  
100-108 Soi Verng  
Nakornkasem, New Road,  
Sumpantawong, Bangkok  
10100, THAILAND  
TEL: (02) 224-8821

## VIET NAM

**VIET THUONG CORPORATION**  
386 CACH MANG THANG TAM ST.  
DIST.3, HO CHI MINH CITY,  
VIET NAM  
TEL: (08) 9316540

## OCEANIA

### AUSTRALIA/

### NEW ZEALAND

**Roland Corporation  
Australia Pty.,Ltd.**  
38 Campbell Avenue, Dee Why  
West. NSW 2099, AUSTRALIA

For Australia  
TEL: (02) 9982 8266

For New Zealand  
TEL: (09) 3098 715

## CENTRAL/LATIN AMERICA

### ARGENTINA

**Instrumentos Musicales S.A.**  
Av.Santa Fe 2055  
(1123) Buenos Aires, ARGENTINA  
TEL: (011) 4508-2700

### BARBADOS

**A&B Music Supplies LTD**  
12 Webster Industrial Park  
Wilsey, St.Michael, BARBADOS  
TEL: (246) 430-1100

### BRAZIL

**Roland Brasil Ltda.**  
Rua San Jose, 211  
Parque Industrial San Jose  
Cotia - Sao Paulo - SP, BRAZIL  
TEL: (011) 4615 5666

### CHILE

**Comercial Fancy II S.A.**  
Rut: 96.919.420-1  
Niraniel Cox #739, 4th Floor  
Santiago - Centro, CHILE  
TEL: (02) 384-2180

### COLOMBIA

**CENTRO MUSICAL S.A.S.**  
Parque Industrial del Norte  
Bodega 130  
GIRARDOTA - ANTIOQUIA,  
COLOMBIA  
TEL: (454) 57 77 EXT 115

### COSTA RICA

**JUAN Bansbach Instrumentos  
Musicales**  
Ave.1. Calle 11, Apartado 10237,  
San Jose, COSTA RICA  
TEL: 258-0211

### CURACAO

**Zeelandia Music Center Inc.**  
Orionweg 30  
Curacao, Netherland Antilles  
TEL: (305) 5926866

### DOMINICAN REPUBLIC

**Instrumentos Fernando Giraldez**  
Calle Roberto Pastoriza #325  
Sanchez Naco Santo Domingo,  
DOMINICAN REPUBLIC  
TEL: (809) 683 0305

### ECUADOR

**Mas Musica**  
Rumichaca 822 y Zaruma  
Guayaquil - ECUADOR  
TEL: (593-4) 2302364

### EL SALVADOR

**OMNI MUSIC**  
75 Avenida Norte y Final Alameda  
Juan Pablo II, Edificio No.4010  
San Salvador, EL SALVADOR  
TEL: 262-0788

## GUATEMALA

**Casa Instrumental**  
Calzada Roosevelt 34-01,zona  
11 Ciudad de Guatemala,  
GUATEMALA  
TEL: (502) 599-2888

## HONDURAS

**Almacen Pajaro Azul S.A. de C.V.**  
B.O.Paz Barahona  
3 Ave.11 Calle S.O  
San Pedro Sula, HONDURAS  
TEL: (504) 553-2029

## MARTINIQUE

**Musique & Son**  
Z.I.Les Mangle  
97232 Le Lamentin,  
MARTINIQUE F.W.I.  
TEL: 596 596 426860

## MEXICO

**Casa Veerkamp, s.a. de c.v.**  
Av. Toluca No. 323, Col. Olivar  
de los Padres 01780 Mexico D.F.,  
MEXICO  
TEL: (55) 5668-6699

## Faly Music

Sucursal Capu Blvd. Norte N.3213  
Col. Nueva Aurora Cp.72070  
Puebla, Puebla, MEXICO  
TEL: 01 (222) 2315567 o 97  
FAX: 01 (222) 2266241

## Gama Music S.A. de C.V.

Madero Pte. 810 Colonia Centro  
C.P. 64000 Monterrey, Nuevo  
León, MEXICO  
TEL: 01 (81) 8374-1640 o 8372-4097  
www.gamamusic.com

## Proscenia

Morelos No. 2273  
Col. Arcos Sur  
C.P. 44120 Guadalajara, Jalisco,  
MEXICO  
TEL: 01 (33) 3630-0015

## NICARAGUA

**Bansbach Instrumentos  
Musicales Nicaragua**  
Altamira D'Este Calle Principal  
de la Farmacia 5ta.Avenida  
1 Cuadra al Lago.#503  
Managua, NICARAGUA  
TEL: (505) 277-2557

## PANAMA

**SUPRO MUNDIAL, S.A.**  
Boulevard Andrews, Albrook,  
Panama City, REP. DE PANAMA  
TEL: 315-0101

## PARAGUAY

**WORLD MUSIC**  
Jebai Center 2018, Centro  
CIUDAD DE ESTE, PARAGUAY  
TEL: (595) 615 059

## PERU

**AUDIONET DISTRIBUCIONES  
MUSICALES S.A.**  
Jr. Ramon Dagnino N°201- Jesús  
María  
DISTRITO DE JESUS MARIA  
LIMA, PERU  
TEL: 9 983 47 301 - 51 433 80 83

## TRINIDAD

**AMR Ltd**  
Ground Floor  
Maritime Plaza  
Barataria TRINIDAD W.I.  
TEL: (868) 638 6385

## URUGUAY

**Todo Musica S.A.**  
Francisco Acuna de Figueroa  
1771  
C.P.: 11.800  
Montevideo, URUGUAY  
TEL: (02) 924-2335

## VENEZUELA

**Instrumentos Musicales  
Allegro, C.A.**  
Av.las industrias edf Guitarr  
import #7 zona Industrial de  
Turumo Caracas, VENEZUELA  
TEL: (212) 244-1122

## EUROPE

### BELGIUM/FRANCE/ HOLLAND/ LUXEMBOURG

**Roland Central Europe N.V.**  
Houtstraat 3, B-2260, Oevel  
(Westerlo) BELGIUM  
TEL: (014) 575811

### BOSNIA AND HERZEGOVINA

**Mix-AP Music**  
78000 Banja Luka, Veselina  
Maslese 3,  
BOSNIA AND HERZEGOVINA  
TEL: 65 403 168

### CROATIA

**ART-CENTAR**  
Degenova 3,  
HR - 10000 Zagreb, CROATIA  
TEL: (1) 466 8493

### EUROMUSIC AGENCY

K. Racina 1/15  
HR - 40000 CAKOVEC, CROATIA  
Tel: 40-370-841

### CZECH REPUBLIC

**CZECH REPUBLIC  
DISTRIBUTOR s.r.o**  
Pod Báni 8  
180 00 Praha 8, CZECH REP.  
TEL: 266 312 557

### DENMARK/ESTONIA/ LATVIA/LITHUANIA

**Roland Scandinavia A/S**  
Skagerrakvej 7, DK-2150  
Nordhavn, DENMARK  
TEL: 39166200

### FINLAND

**Roland Scandinavia As, Filial**  
Finland  
Vanha Nurmjarventie 62  
01670 Vantaa, FINLAND  
TEL: (0) 9 68 24 020

### GERMANY/AUSTRIA

**ROLAND Germany GmbH.**  
Adam-Opel-Strasse 4, 64569  
Nauheim, GERMANY  
TEL: 6152 95546-00

### GREECE/CYPRUS

**STOLAS S.A.**  
**Music Sound Light**  
155, New National Road  
Patras 26442, GREECE  
TEL: 2610 435400

### HUNGARY

**Roland East Europe Ltd.**  
2045.Törökbalint, FSD Park 3. ép.,  
HUNGARY  
TEL: (23) 511 011

### IRELAND

**Roland Ireland**  
E2 Calmount Park, Calmount  
Avenue, Dublin 12,  
Republic of IRELAND  
TEL: (01) 4294444

### ITALY

**Roland Italy S. p. A.**  
Viale delle Industrie 8,  
20020 Aresè, Milano, ITALY  
TEL: (02) 937781

### MACEDONIA

**MK MUJZIK**  
Bratstvo Edinstvo 9  
2208 Lozovo, MACEDONIA  
TEL: 70 264 458

### MONTENEGRO

**MAX-AP**  
P. Fah 92  
Przno, Kamenovo bb  
86000 Budva, MONTENEGRO  
TEL: 33 452-820

### NORWAY

**Roland Scandinavia Avd.  
Kontor Norge**  
Lilleakerveien 2 Postboks 95  
Lilleaker N-0216 Oslo,  
NORWAY  
TEL: 2273 0074

## POLAND

**ROLAND POLSKA SP. Z O.O.**  
ul. Katy Grodziskie 16B  
03-289 Warszawa, POLAND  
TEL: (022) 678 9512

## PORTUGAL

**Roland Iberia SL.  
Branch Office Porto**  
Edificio Tower Plaza  
Rotunda Eng. Edgar Cardoso 23,  
4-8  
4400-676 Vila Nova de Gaia,  
PORTUGAL  
TEL: (+351) 22 608 00 60

## ROMANIA

**Pro Music Concept SRL**  
440221 Satu Mare  
B-dul Independentei nr. 14/a.,  
ROMANIA  
TEL: (0361) 807-333

## RUSSIA

**Roland Music LLC**  
Dorozhnaya ul.3,korp.6  
117 545 Moscow, RUSSIA  
TEL: (495) 981-4967

## SERBIA

**Music AP**  
Sutjeska br. 5 XS - 24413 PALIC,  
SERBIA  
TEL: (0) 24 539 395

## SLOVAKIA

**DAN Distribution, s.r.o.**  
Povazská 18,  
SK - 940 01 Nové Zámky,  
SLOVAKIA  
TEL: (035) 6424 330

## SPAIN

**Roland Systems Group EMEA, S.L.**  
Paseo García Faria, 33-35  
08005 Barcelona, SPAIN  
TEL: 93 493 91 00

## SWEDEN

**Roland Scandinavia A/S**  
**SWEDISH SALES OFFICE**  
Märbackagatan 31, 4 tr.  
SE-123 43 Farsta, SWEDEN  
TEL: (0) 8 683 04 30

## SWITZERLAND

**Roland (Switzerland) AG**  
Landstrasse 5, Postfach,  
CH-4452 Ittingen, SWITZERLAND  
TEL: (061) 975-9987

## TURKEY

**ZUHAL DIS TICARET A.S.**  
Galip Dede Cad. No.33  
Beyoglu, Istanbul, TURKEY  
TEL: (0212) 249 85 10

## UKRAINE

**EURHYTHMICS Ltd.**  
P.O.Box: 37-a.  
Nedecey Str. 30  
UA - 89600 Mukachevo,  
UKRAINE  
TEL: (03131) 314-40

## UNITED KINGDOM

**Roland (U.K.) Ltd.**  
Atlantic Close, SWANSEA SA7  
9FJ, UNITED KINGDOM  
TEL: (01792) 702701

## MIDDLE EAST

### BAHRAIN

**Moon Stores**  
No.1231&1249 Rumaytha  
Building Road 3931,  
Manama 339, BAHRAIN  
TEL: 17 813 942

### EGYPT

**Al Fanny Trading Office**  
9, EBN Hagar Al Askalany Street,  
ARD E1 Golf, Heliopolis,  
Cairo 11341, EGYPT  
TEL: (022)-417-1828

## IRAN

**MOCO INC.**  
Jadeh Makhsous Karaj (K-9),  
Nakhe Zarin Ave.  
Jalal Street, Reza Alley No.4  
Tehran 1389716791, IRAN  
TEL: (021)-44545370-5

## ISRAEL

**Haliit P. Greenspoon &  
Sons Ltd.**  
8 Retzif Ha'alia Hashnia St.  
Tel-Aviv-Yafo ISRAEL  
TEL: (03) 6823666

## JORDAN

**MUSIC HOUSE CO. LTD.**  
**FREDDY FOR MUSIC**  
P. O. Box 922846  
Amman 11192, JORDAN  
TEL: (06) 5692696

## KUWAIT

**EASA HUSAIN AL-YOUSIFI &  
SONS CO.**  
Al-Yousif Service Center  
P.O.Box 126 (Safat) 13002,  
KUWAIT  
TEL: 00 965 802929

## LEBANON

**Chahine S.A.L.**  
George Zeidan St., Chahine Bldg.,  
Achrafieh, P.O.Box: 16-5857  
Beirut, LEBANON  
TEL: (01) 20-1441

## OMAN

**TALENTZ CENTRE L.L.C.**  
Malaten House No.1  
Al Noor Street, Ruwi  
SULTANATE OF OMAN  
TEL: 2478 3443

## QATAR

**AL-EMADI TRADING &  
CONTRACTING CO.**  
P.O. Box 62, Doha, QATAR  
TEL: 4423-554

## SAUDI ARABIA

**Adawiah Universal  
Electronics APL**  
Behind Pizza Inn  
Prince Turkey Street  
Adawiah Building,  
PO BOX 2154,  
Al Khobar 31952,  
SAUDI ARABIA  
TEL: (03) 8643601

## SYRIA

**Technical Light & Sound Center**  
PO Box 13520 Bldg No.49  
Khaled Abn Alwalid St.  
Damascus, SYRIA  
TEL: (011) 223-5384

## U.A.E.

**Adawiah Universal  
Electronics APL**  
Omar bin alKhattab street, fish  
round about, nayef area, deira,  
Dubai, U.A.E.  
TEL: (04) 2340442

## NORTH AMERICA

### CANADA

**Roland Canada Ltd.  
(Head Office)**  
5480 Parkwood Way Richmond  
B. C., V6V 2M4, CANADA  
TEL: (604) 270 6626

### Roland Canada Ltd. (Toronto Office)

170 Admiral Boulevard  
Mississauga On L5T 2N6,  
CANADA  
TEL: (905) 362 9707

### U. S. A.

**Roland Corporation U.S.**  
5100 S. Eastern Avenue  
Los Angeles, CA 90040-2938,  
U. S. A.  
TEL: (323) 890 3700

As of Nov. 1, 2013 (ROLAND)

## For EU Countries



- UK** This symbol indicates that in EU countries, this product must be collected separately from household waste, as defined in each region. Products bearing this symbol must not be discarded together with household waste.
- DE** Dieses Symbol bedeutet, dass dieses Produkt in EU-Ländern getrennt vom Hausmüll gesammelt werden muss gemäß den regionalen Bestimmungen. Mit diesem Symbol gekennzeichnete Produkte dürfen nicht zusammen mit den Hausmüll entsorgt werden.
- FR** Ce symbole indique que dans les pays de l'Union européenne, ce produit doit être collecté séparément des ordures ménagères selon les directives en vigueur dans chacun de ces pays. Les produits portant ce symbole ne doivent pas être mis au rebut avec les ordures ménagères.
- IT** Questo simbolo indica che nei paesi della Comunità europea questo prodotto deve essere smaltito separatamente dai normali rifiuti domestici, secondo la legislazione in vigore in ciascun paese. I prodotti che riportano questo simbolo non devono essere smaltiti insieme ai rifiuti domestici. Ai sensi dell'art. 13 del D.Lgs. 25 luglio 2005 n. 151.
- ES** Este símbolo indica que en los países de la Unión Europea este producto debe recogerse aparte de los residuos domésticos, tal como esté regulado en cada zona. Los productos con este símbolo no se deben depositar con los residuos domésticos.
- PT** Este símbolo indica que nos países da UE, a recolha deste produto deverá ser feita separadamente do lixo doméstico, de acordo com os regulamentos de cada região. Os produtos que apresentem este símbolo não deverão ser eliminados juntamente com o lixo doméstico.
- NL** Dit symbool geeft aan dat in landen van de EU dit product gescheiden van huishoudelijk afval moet worden aangeboden, zoals bepaald per gemeente of regio. Producten die van dit symbool zijn voorzien, mogen niet samen met huishoudelijk afval worden verwijderd.
- DK** Dette symbol angiver, at i EU-lande skal dette produkt opsamles adskilt fra husholdningsaffald, som defineret i hver enkelt region. Produkter med dette symbol må ikke smides ud sammen med husholdningsaffald.
- NO** Dette symbolet indikerer at produktet må behandles som spesialavfall i EU-land, iht. til retningslinjer for den enkelte regionen, og ikke kastes sammen med vanlig husholdningsavfall. Produkter som er merket med dette symbolet, må ikke kastes sammen med vanlig husholdningsavfall.
- SE** Symbolen anger att i EU-länder måste den här produkten kasseras separat från hushållsavfall, i enlighet med varje regions bestämmelser. Produkter med den här symbolen får inte kasseras tillsammans med hushållsavfall.
- FI** Tämä merkintä ilmaisee, että tuote on EU-maissa kerättävä erillään kotitalousjätteistä kunkin alueen voimassa olevien määräysten mukaisesti. Tällä merkinnällä varustettuja tuotteita ei saa hävittää kotitalousjätteiden mukana.
- HU** Ez a szimbólum azt jelenti, hogy az Európai Unióban ezt a terméket a háztartási hulladéktól elkülönítve, az adott régióban érvényes szabályozás szerint kell gyűjteni. Az ezzel a szimbólummal ellátott termékeket nem szabad a háztartási hulladék közé dobni.
- PL** Symbol oznacza, że zgodnie z regulacjami w odpowiednim regionie, w krajach UE produktu nie należy wyrzucać z odpadami domowymi. Produktów opatrzonych tym symbolem nie można utylizować razem z odpadami domowymi.
- CZ** Tento symbol udává, že v zemích EU musí být tento výrobek sbírán odděleně od domácího odpadu, jak je určeno pro každý region. Výrobky nesoucí tento symbol se nesmí vyhazovat spolu s domácím odpadem.
- SK** Tento symbol vyjadruje, že v krajinách EÚ sa musí zber tohto produktu vykonávať oddelene od domového odpadu, podľa nariadení platných v konkrétnej krajine. Produkty s týmto symbolom sa nesmú vyhazovať spolu s domovým odpadom.
- EE** See sümbol näitab, et EL-i maades tuleb see toode olemprügist eraldi koguda, nii nagu on igas piirkonnas määratletud. Selle sümboliga märgitud tooteid ei tohi ära visata koos olmeprügiga.
- LT** Šis simbolis rodo, kad ES šalyse šis produktas turi būti surenkamas atskirai nuo buitinių atliekų, kaip nustatyta kiekviename regione. Šiuo simboliu paženklinėti produktai neturi būti išmetami kartu su buitinėmis atliekomis.
- LV** Šis simbols norāda, ka ES valstīs šo produktu jāievāc atsevišķi no mājsaimniecības atkritumiem, kā noteikts katrā reģionā. Produktus ar šo simbolu nedrīkst izmest kopā ar mājsaimniecības atkritumiem.
- SI** Ta simbol označuje, da je treba proizvod v državah EU zbirati ločeno od gospodinjskih odpadkov, tako kot je določeno v vsaki regiji. Proizvoda s tem znakom ni dovoljeno odlagati skupaj z gospodinjskimi odpadki.
- GR** Το σύμβολο αυτό υποδηλώνει ότι στις χώρες της Ε.Ε. το συγκεκριμένο προϊόν πρέπει να συλλέγεται χωριστά από τα υπόλοιπα οικιακά απορρίμματα, σύμφωνα με όσα προβλέπονται σε κάθε περιοχή. Τα προϊόντα που φέρουν το συγκεκριμένο σύμβολο δεν πρέπει να απορρίπτονται μαζί με τα οικιακά απορρίμματα.

## For China

### 有关产品中所含有害物质的说明

本资料就公司产品中所含的特定有害物质及其安全性予以说明。

本资料适用于 2007 年 3 月 1 日以后本公司所制造的产品。

#### 环保使用期限



此标志适用于在中国国内销售的电子信息产品，表示环保使用期限的年数。所谓环保使用期限是指在自制造日起的规定期限内，产品中所含的有害物质不致引起环境污染，不会对人身、财产造成严重的不良影响。环保使用期限仅在遵照产品使用说明书，正确使用产品的条件下才有效。不当的使用，将会导致有害物质泄漏的危险。

#### 产品中有毒有害物质或元素的名称及含量

部件名称	有毒有害物质或元素					
	铅(Pb)	汞(Hg)	镉(Cd)	六价铬(Cr(VI))	多溴联苯(PBB)	多溴二苯醚(PBDE)
外壳(壳体)	×	○	○	○	○	○
电子部件(印刷电路板等)	×	○	×	○	○	○
附件(电源线、交流适配器等)	×	○	○	○	○	○

○：表示该有毒有害物质在该部件所有均质材料中的含量均在 SJ/T11363-2006 标准规定的限量要求以下。

×：表示该有毒有害物质至少在该部件的某一均质材料中的含量超出 SJ/T11363-2006 标准规定的限量要求。

因根据现有的技术水平，还没有什么物质能够代替它。

## FEDERAL COMMUNICATIONS COMMISSION RADIO FREQUENCY INTERFERENCE STATEMENT

This equipment has been tested and found to comply with the limits for a Class B digital device, pursuant to Part 15 of the FCC Rules. These limits are designed to provide reasonable protection against harmful interference in a residential installation. This equipment generates, uses, and can radiate radio frequency energy and, if not installed and used in accordance with the instructions, may cause harmful interference to radio communications. However, there is no guarantee that interference will not occur in a particular installation. If this equipment does cause harmful interference to radio or television reception, which can be determined by turning the equipment off and on, the user is encouraged to try to correct the interference by one or more of the following measures:

- Reorient or relocate the receiving antenna.
- Increase the separation between the equipment and receiver.
- Connect the equipment into an outlet on a circuit different from that to which the receiver is connected.
- Consult the dealer or an experienced radio/TV technician for help.

This device complies with Part 15 of the FCC Rules. Operation is subject to the following two conditions:

- (1) this device may not cause harmful interference, and
- (2) this device must accept any interference received, including interference that may cause undesired operation.

This equipment requires shielded interface cables in order to meet FCC class B limit.

Any unauthorized changes or modifications not expressly approved by the party responsible for compliance could void the user's authority to operate the equipment.

CAN ICES-3 (B)/NMB-3 (B)

### 사용자 안내문

기종별	사용자 안내문
B 급 기기 (가정용 방송통신기자재)	이 기기는 가정용(B 급) 전자파적합기기로서 주로 가정에서 사용하는 것을 목적으로 하며, 모든 지역에서 사용할 수 있습니다.

### WARNING

This product contains chemicals known to cause cancer, birth defects and other reproductive harm, including lead.

## DECLARATION OF CONFORMITY Compliance Information Statement

Model Name : RD-800  
 Type of Equipment : Digital Piano  
 Responsible Party : Roland Corporation U.S.  
 Address : 5100 S. Eastern Avenue Los Angeles, CA 90040-2938  
 Telephone : (323) 890-3700



# List of Shortcut Keys

\* “[A]+[B]” indicates the operation of “holding down the [A] button and pressing the [B] button.”

Shortcut	Explanation	Page
<b>Basic operation</b>		
[SHIFT] + [DEC] [INC], value dial	Makes the value change more greatly. When switching tones, the first sound in the category is selected. When switching Live Sets, the first sound in the bank is selected.	p. 13, p. 17
[SHIFT] + [◀] [▶]	If the Layer Edit screen or MIDI Control screen is shown, move between pages.	p. 28, p. 37
<b>Registering the desired sounds in a TONE or LIVE SET</b>		
Currently selected TONE button + [WRITE]	Memorizes the currently selected Tone number. The next time you press the same button, the memorized Tone will be selected.	p. 13
Currently selected LIVE SET button + [WRITE]	Memorizes the currently selected Live Set number. The next time you press the same button, the memorized Live Set will be selected.	p. 13
<b>Changing the order of Live Sets (Live Set Swap)</b>		
[SHIFT] + LIVE SET [A] – [J]	Changes the order of Live Sets.	p. 23
<b>Editing a tone or Live Set</b>		
[TRANPOSE] + keyboard, [DEC] [INC], value dial	Specifies the transposition setting of the entire keyboard.	p. 12
[SPLIT/LOWER SELECT] + TONE button, [DEC] [INC], value dial	Selects the LOWER tone when using Split.	p. 13
[SPLIT/LOWER SELECT] + keyboard	Specifies the split point.	p. 13
[RHYTHM/SONG] + [DEC] [INC]	When rhythm is selected, specifies the rhythm volume. When an audio song is selected, specifies the audio volume.	p. 24, p. 25
[SHIFT] + LAYER switch ([UPPER1] – [LOWER])	Jumps to the Designer Menu screen for each layer.	p. 32
[SHIFT] + LAYER LEVEL slider (*1)	Jumps to the VOL (Volume) item of the Layer Edit screen.	p. 28, p. 38
[SHIFT] + [TRANPOSE] (*1)	Jumps to the C.Tune (Coarse Tune) item of the Layer Edit screen.	p. 28, p. 39
[SHIFT] + [SPLIT] (*1)	Jumps to the KR.LWR (Keyboard Range Lower) item of the Layer Edit screen.	p. 28, p. 39
[SHIFT] + [LIVE SET EDIT]	Jumps to the Layer Edit screen.	p. 28
<b>Reverb</b>		
[SHIFT] + REVERB knob	Jumps to the Reverb screen.	p. 14, p. 31
LAYER switch ([UPPER1] – [LOWER]) + REVERB knob (*1)	Adjusts each layer's reverb depth (Reverb Send Level).	p. 28, p. 38
<b>Tone color</b>		
[SHIFT] + TONE COLOR knob	Jumps to the TON CLR (Tone Color Control Destination) item of the Layer Edit screen.	p. 20
<b>EQ/DELAY/ASSIGN</b>		
[SHIFT] + each EQ knobs (LOW, MID1, MID2, HIGH)	Changes the center frequency of each equalizer band.	p. 15
[SHIFT] + each DELAY knobs (TYPE, LEVEL, FEEDBACK, TIME)	Jumps to the Delay screen.	p. 15, p. 31
[SHIFT] + DELAY [ON/OFF]	Jumps to the DLY (Delay Send Level) item of the Layer Edit screen.	p. 28
LAYER switch ([UPPER1] – [LOWER]) + DELAY [LEVEL] knob	Adjusts each layer's delay depth (Delay Send Level).	p. 28
[SHIFT] + each ASSIGN knobs (1–4)	Jumps to the Assign 1-5 screen.	p. 15 p. 30
[SHIFT] + ASSIGN [5] (*1)	Jumps to the A5 (Assign 5 Control Switch) item of the Layer Edit screen.	p. 28, p. 39
<b>Modulation FX</b>		
MOD FX [ON/OFF] + [DEC] [INC], value dial	Changes the modulation FX type of the layer that's selected in Modulation FX Control Destination.	p. 14
[SHIFT] + MOD FX [DEPTH], [RATE] knob	Jumps to the Modulation FX screen of the layer that's selected in Modulation FX Control Destination.	p. 35
[SHIFT] + MOD FX [ON/OFF]	Jumps to the MOD FX (Modulation FX Control Destination) item of the Layer Edit screen.	p. 28
<b>Tremolo/amp simulator</b>		
TREMOLO [ON/OFF] + [DEC] [INC], value dial	Changes the tremolo/amp simulator type of the layer that's selected in Tremolo/Amp Control Destination.	p. 14
AMP SIM [ON/OFF] + [DEC] [INC], value dial		
[SHIFT] + TREMOLO [DEPTH], [RATE] knob	Jumps to the Tremolo/Amp Simulator screen of the layer that's selected in Tremolo/Amp Control Destination.	p. 35
[SHIFT] + AMP SIM [DRIVE] knob		
[SHIFT] + TREMOLO [ON/OFF]	Jumps to the TR/AMP (Tremolo/Amp Control Destination) item of the Layer Edit screen.	p. 28
[SHIFT] + AMP SIM [ON/OFF]		
<b>S1/S2</b>		
[SHIFT] + [S1]	Jumps to the S1/S2 screen.	p. 30
[SHIFT] + [S2] (*1)	Jumps to the S2 item of the Layer Edit screen.	p. 28, p. 39
<b>Pitch bend lever/modulation lever</b>		
[SHIFT] + pitch bend lever (*1)	Jumps to the PB (Pitch Bend Control Switch) item of the Layer Edit screen.	p. 28, p. 39
[SHIFT] + modulation lever (*1)	Jumps to the MD (Modulation Control Switch) item of the Layer Edit screen.	p. 28, p. 39
<b>Pedal</b>		
[SHIFT] + pedal (DAMPER) (*1)	Jumps to the DAMP (Damper Control Switch) item of the Layer Edit screen.	p. 28, p. 39
[SHIFT] + pedal (FC1, FC2, EXT)	Jumps to the Pedal screen.	p. 29
<b>Panel lock</b>		
[MENU] + [ENTER]	Enables panel lock.	p. 12
<b>When entering a name</b>		
[SHIFT] + [▲]	Switch character sets.	p. 23, p. 25
[SHIFT] + [▼]	Switch uppercase/lowercase.	p. 23, p. 25
[SHIFT] + [◀]	Delete one character (DELETE).	p. 23, p. 25
[SHIFT] + [▶]	Insert one space (INSERT).	p. 23, p. 25

\*1: If the [MIDI CONTROL] button is lit, makes settings for the External layer.

